

J700

DFMT Elite

Digital Floor Mounted Tubestand

Installation and Operation Manual

05396 Rev M

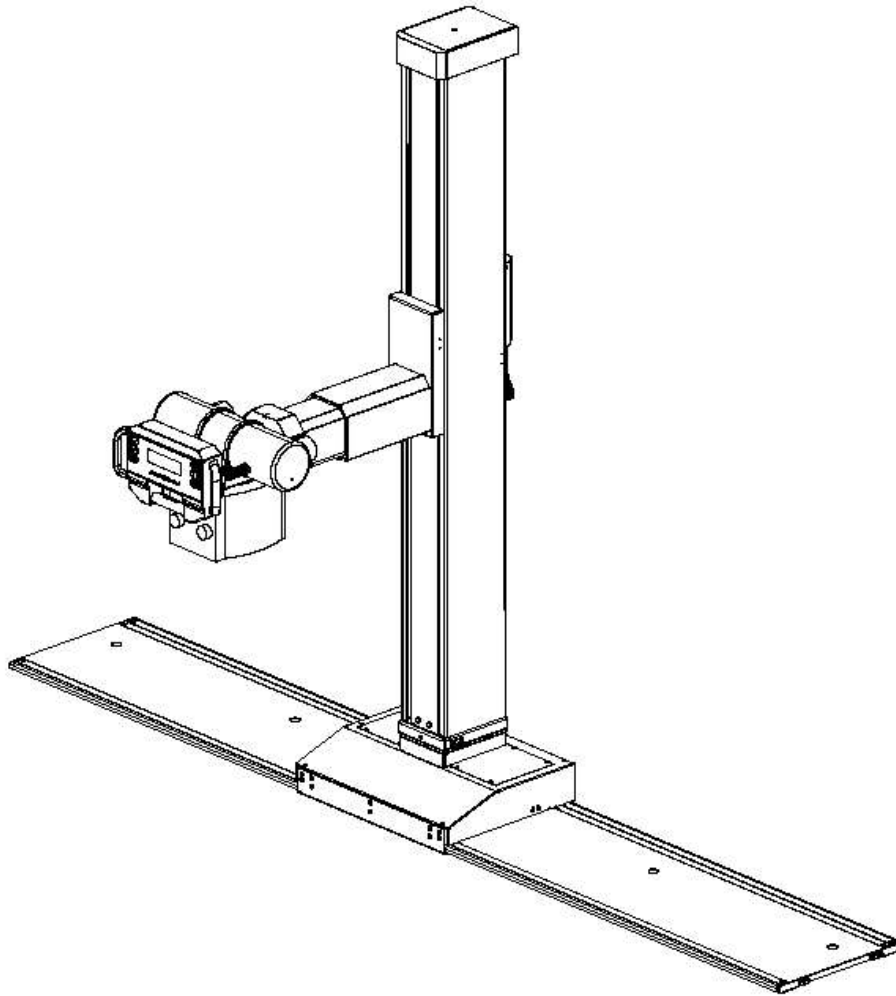

SUMMIT INDUSTRIES, LLC
7555 N. Caldwell Ave.
Niles, IL 60714
773-588-2444

www.SummitIndustries.net

Revision History

Rev	Description	ECR	Released
A	Released for Production		10-15-2010
B	Update to floor rail with three tracks, rewrote maintenance section		Oct 2014
C	Updated 1.1 “J700 draws less than 1 Amp continuously” changed to “J700 draws less than 2 Amps continuously”; Removed 1.3; Replaced 1.2 with new Symbol Table.		Nov 2016
D	Replaced section 5.9 with updated instructions; Update graphics on pg 9-3.	9508	April 2017
E	Updated address to Niles, IL; Modified Warning statement on sheet ii; Added “Intended Use” statement on sheet ii.	9600	June 2017
F	Fix incorrect floor rail hole callout in section 3.1.2	9845	Mar 2018
G	Restructured manual—updated product to DFMT Elite	10365	Dec 2019
H	Removed E14 & E15, not implemented in software; Updates per tech service	10407	Jan 2020
J	Added configuration directions to page 6.1. Added notes to section 6.2. Updated Dimensions and Layout in section 2.1 Added note to section 6.4 to follow section 5.2	10478	Mar 2020
K	Updated Electrical Ratings in section 1.4 Added section 8.5 for Fuses	10566	Aug 2020
L	Updated sheet 16, “CENTER” row, Step 6 – Added “Needed for recalibration of the system – SKIP this step for initial / installation calibration.”	11317	Oct 2023
M	Section 6.3 (page 15) – Added highlights to COMPONENT SETUP of table.	11425	May 2024

TABLE OF CONTENTS

1. GENERAL INFORMATION	1
1.1 Introduction	1
1.2 Definition of Symbols Used on the Equipment	1
1.3 Notices/Safety	2
1.4 Specifications	3
1.5 Shipment and Handling	3
2. PRE-INSTALLATION INFORMATION	3
2.1 Tubestand Dimensions and Layout.....	4
2.2 Floor Preparation	4
2.3 Power.....	4
2.4 Unpack and Inventory	4
3. INSTALLATION	5
3.1 Mount the Floor Rail.....	5
3.2 Install the Column	5
3.3 Mount the X-ray Tube and Collimator	7
3.4 Install the Angulation Box.....	8
3.5 Install the High Voltage Cables	9
4. TUBESTAND LEVELING AND ADJUSTMENT	9
4.1 Trim the Counterweight.....	9
4.2 Column Leveling	9
4.3 Transverse Arm Leveling	10
4.4 Align the Collimator Light Source to the X-Ray Field	11
5. FINAL ASSEMBLY ITEMS	11
5.1 Connect the Table Vertical Potentiometer.....	11
5.2 Install the Horizontal SID Actuators (for SID Switches).....	11
5.3 Horizontal SID labeling.....	12
5.4 Install the Cable Sleeve Kit	12
6. CALIBRATION	13
6.1 Feature Configuration	13
6.2 Tube Angle Calibration (<i>Proceed in the order below</i>)	14
6.3 Vertical SID Calibration (<i>Proceed in the order below</i>).....	15
6.4 Horizontal SID Calibration (<i>Proceed in the order below. HSID section on page 11 must be followed</i>).....	16
6.5 Engage the Horizontal SID Assembly	17
7. RECOMMENDED MAINTENANCE	18
7.1 Tubestand.....	18
7.2 Collimator.....	18
7.3 X-Ray Tube.....	18
8. DIAGNOSTICS	19
8.1 Error Code Table	19
8.2 Error Code Locations	20
8.3 Error Codes of Angulation Box Button LEDs.....	20
8.4 Error Codes of Angulation Box LCD	20
8.5 Fuses	21
9. DFMT OPERATION	22
9.1 Buttons and Display Indicators.....	22
9.2 Other Features.....	24

9.3 Typical Displays (product configured for inches).....25

1. GENERAL INFORMATION

1.1 Introduction

This Floor Mounted Tubestand with Digital Display (DFMT) is a moveable support system for an X-ray tube and collimator. The unit can be used for all general-purpose diagnostic techniques and is composed of the column assembly and the floor rail.

This DFMT is compatible with all certified tube housing assemblies, X-ray controls, X-ray high voltage generators, cassette holders, and beam limiting devices. This Tubestand will not affect regulatory compliance of these components when these components are installed, connected, and adjusted in accordance with the applicable manufacturer’s instructions and specifications.

1.2 Definition of Symbols Used on the Equipment

Symbol Legend	
Symbol	Definition
	Date of manufacture
	Manufacturer
	Serial Number
	Reference Number (Model/Part Number)
	Keep Dry
	This symbol represents Information that assists the user of the manual in the performance of a task. It may provide the user with better methods of conducting the task, or it may point out conditions that could cause the system to fail to operate properly.
	Points out special procedures, or precautions, that personnel must follow to avoid equipment damage.
	Identifies situations or actions that may affect patient or user safety. Disregarding a warning could result in patient or user injury.
	TYPE B APPLIED PART This symbol indicates equipment providing a particular degree of protection against electric shock, particularly regarding allowable leakage currents and reliability of the protective earth connection (if present).
	This symbol indicates an Electro Sensitive Device is present which must be carefully handled to prevent damage to the device.
	ELECTRIC SHOCK HAZARD WARNING This symbol indicates an electric shock hazard.
	DANGER VOLTAGE This symbol indicates hazards arising from dangerous voltages.
	DIRECT CURRENT This symbol indicates a direct current source.
	PROTECTIVE EARTH TERMINATIONS This symbol indicates protective earth terminations in device.
	Safety Label

1.3 Notices/Safety

1.3.1 Service and Operation



CAUTION

THIS MANUAL IS FOR USE BY PERSONNEL QUALIFIED TO INSTALL, MAINTAIN, AND OPERATE THIS EQUIPMENT.

Only qualified personnel should install, maintain, and operate this equipment. Familiarize all operators with how to use the system properly. Only qualified service personnel should remove electrical covers.

The manufacturer does not accept responsibility for any of the following:

Equipment improperly installed, operated, maintained, or repaired.

Equipment which has been modified in any way.

Harm to patient or other personnel for any of the above causes.



WARNING

X-RAY EQUIPMENT CAN BE DANGEROUS TO BOTH PATIENT AND OPERATOR UNLESS PROPER SAFETY MEASURES ARE OBSERVED.

All operators of this equipment should be familiar with regulations and recommendations of industry authorities. These can include:

State Department of Health

Code of Federal Regulations (21 CFR subchapter J Radiological Health)

National Council on Radiation Protection and Measurements (NCRP 33 or successor)

International Commission on Radiological Protection (ICRP 26 or successor)

1.3.2 Radiation Protection

Adequate precautions must be taken to prevent unauthorized or unqualified persons from operating this equipment or exposing themselves or others to its radiation.

All operators of this equipment are to comply with regulations and recommendations of industry authorities (see list, previous section).

The manufacturer, its agents, and representatives do not accept any responsibility for overexposure of patients or personnel to x-ray radiation, including that which is the result of poor operating techniques or procedures.

1.3.3 Servicing the Product



WARNING

MOVING PARTS AND HIGH VOLTAGES CAN BE EXPOSED THAT CAN CAUSE SERIOUS INJURY WHEN ACCESS PANELS ARE REMOVED. DISCONNECT POWER PRIOR TO SERVICING AND WEAR PROTECTIVE EYEWEAR.

Only properly trained and qualified personnel shall access any internal parts of the x-ray system.

1.3.4 Intended Use

This is an x-ray tubestand, a mechanical device intended to support and position an x-ray tube and collimator as required for radiographic procedures.

1.3.5 Estimated Useful Product Life

This product has an estimated useful life of 15 years from the date of manufacture. Repair costs and technical obsolescence prohibit maintaining the equipment beyond that point.

1.4 Specifications

SPECIFICATION SUMMARY TABLE	
Electrical Ratings	100-120 VAC, 50/60 Hz, 0.8 A 200-240 VAC, 50/60 Hz, 0.4 A
Maximum Support Load (Tube and Collimator)	70 lbs (32 kg)
Environmental conditions for operation	<i>Temperature: 50° F to 104° F (10° C to 40° C)</i> <i>Relative humidity: 30% to 75%, non-condensing</i> <i>Atmospheric pressure: 70.0–106.0 kPa</i>
Environmental Conditions for transport, storage, and operation	<i>Temperature: -4° F to 122° F (-20° C to 50° C)</i> <i>Relative humidity: 10% to 100%, non-condensing</i> <i>Atmospheric pressure: 50.0–108.0 kPa</i>
Information regarding potential EMC interference and advice for avoidance	<ul style="list-style-type: none"> • Main power quality should be that of a typical commercial or hospital environment • Power frequency magnetic fields should be at levels characteristic of a typical location in a commercial or hospital environment
Degree of protection against harmful ingress of water	IPX0 (No protection)
Degree of protection against electric shock	Class I, Type B Applied Parts 
Compliant regulatory and design standards	UL 60601-1 CAN/CSA C22.2 No. 601.1, CAN/CSA C22.2 No. 01.2.32-98 X-RAY EQUIPMENT IEC 60601-2-32:1994
Equipment not suitable for use with flammable anesthetic mixture with air or with oxygen or nitrous oxide.	

1.5 Shipment and Handling

Exercise caution when moving and unpacking equipment.

Once delivered, inspect the product for evident and concealed damage. It is the responsibility of the dealer to make all shipping claims as all equipment is shipped FOB from the factory.

If it is necessary to store the product before delivery to the installation site select a dry location with moderate temperatures.

Open the crates and cartons carefully. Do not dispose of them until you have located all parts and the machine is fully assembled.

2. PRE-INSTALLATION INFORMATION

Due to the weight of the J700 column assembly additional personnel or a mechanical lifting device may be necessary to safely lift and position it on the floor rail.

Each installation site is different. Verify that the planned installation allows fit and travels of all the equipment. For sites with a table and wallstand those components should be installed and aligned after the tubestand.

Conventional radiographic room construction should be used. Consult the State Health Department and local building codes for specific radiation shielding requirements.

2.1 Tubestand Dimensions and Layout

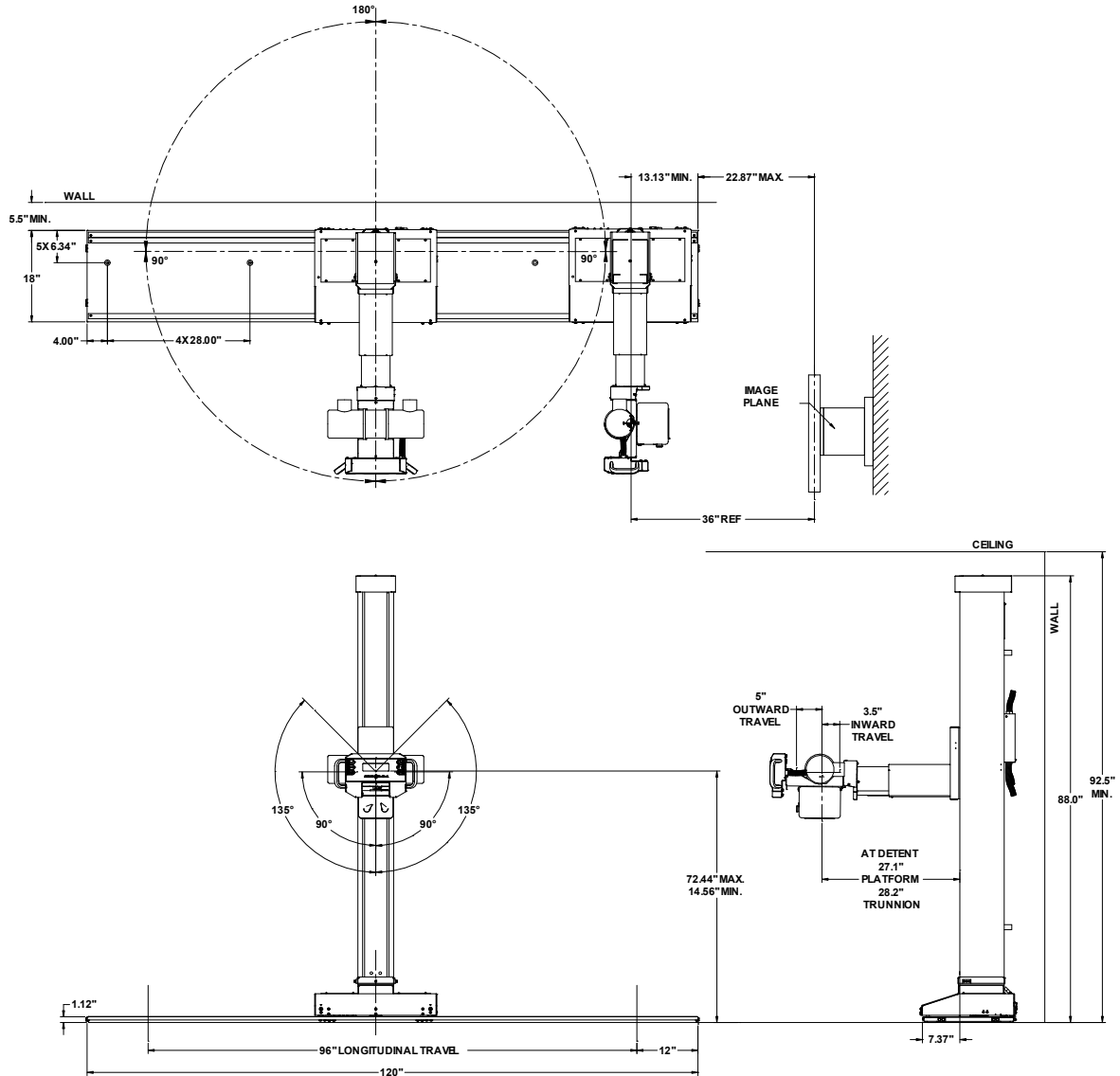

2.2 Floor Preparation

Shims are provided to assist in leveling the floor rail within $\pm 1/16$ laterally (front to back) and $\pm 1/32$ longitudinally (left to right). If the floor under the floor rail is very uneven it is recommended to apply a hardening leveler to the floor before installation to avoid a large number of shims and a large gap between the rail and the floor.

2.3 Power

The DFMT requires 115/230 VAC 50/60 Hz power (See section 1.4 for current requirements) and comes with a standard US wall plug and 20-ft cable. Be sure there is an outlet available close enough to the installation location.

2.4 Unpack and Inventory

Check the hardware received against the system order packing list. Confirm presence of all accessories and the angulation box. Call technical support to report any missing or damaged items.

3. INSTALLATION

3.1 Mount the Floor Rail

The Floor Rail is the first component to be installed. It must be leveled and aligned properly in the room to achieve proper X-ray beam alignment. Refer to the diagram in section 2.1 for floor rail dimensions. Orient the floor rail as shown in the diagram (two tracks in the rear, one in the front).

3.1.1 Hardware Kit

Anchors and hardware are provided in a kit taped to the bottom of the floor rail assembly. The supplied anchors are stud-type for concrete/masonry. If these will not work with the site floor material you must source your own, appropriate anchors.

If using the included floor anchors for concrete/masonry and the holes were not previously drilled, use the floor rail mounting holes as a template to drill 3/8" Dia, 1.75" deep holes into the floor.

4.1.2 Mounting the Floor Rail

Insert a floor anchor in each of the holes, but DO NOT tighten at this time. Use the shims supplied to level the floor rail in all directions. Tighten the anchor bolts and install the decorative hole plugs in the rail mounting holes.

3.2 Install the Column

3.2.1 Removing the Shipping Bracket/Blocks



WARNING

IN THE FOLLOWING STEPS, YOU WILL FREE THE COLUMN COUNTERWEIGHT AND SLIDE/ARM TO MOVE. USE EXTREME CAUTION--BE PREPARED TO HAVE THE WEIGHTS SHIFT AND UNBALANCE THE COLUMN

With the column horizontal and the transverse arm facing up, remove the counterweight locking screw.

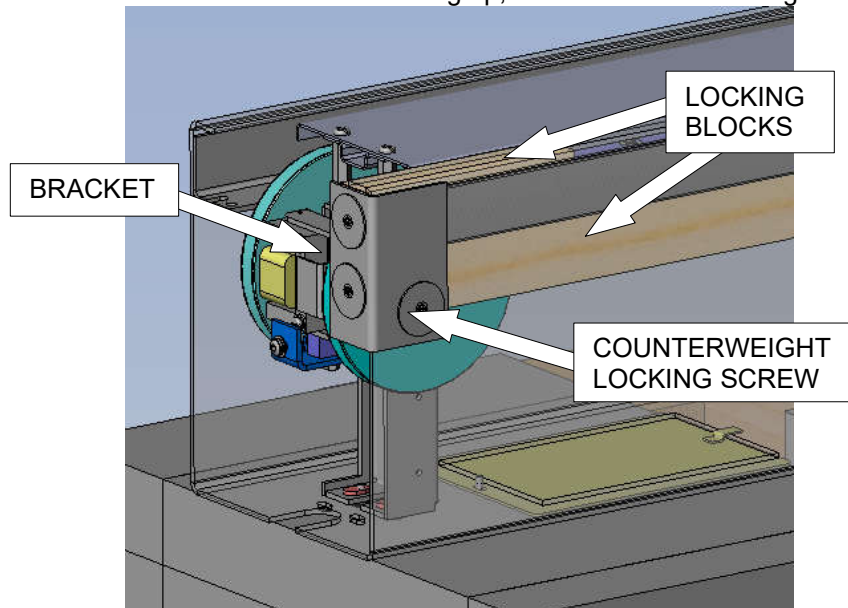

Slide the bracket out with locking blocks attached. Verify that the counterweight cables are properly positioned on the pulleys. Using a long 2x4 or similar item push the counterweight to the bottom of the column to prevent vertical movement when the column is lifted to vertical position.



NOTE

Consider keeping the counterweight shipping blocks/hardware as they may be useful during future maintenance procedures or if the equipment is ever relocated

3.2.2 Lifting the Column

The floor car comes factory-assembled to the column with the electrical connections made. To make standing the column easier it is recommended to remove the front and rear guide bearing brackets from the floor car.

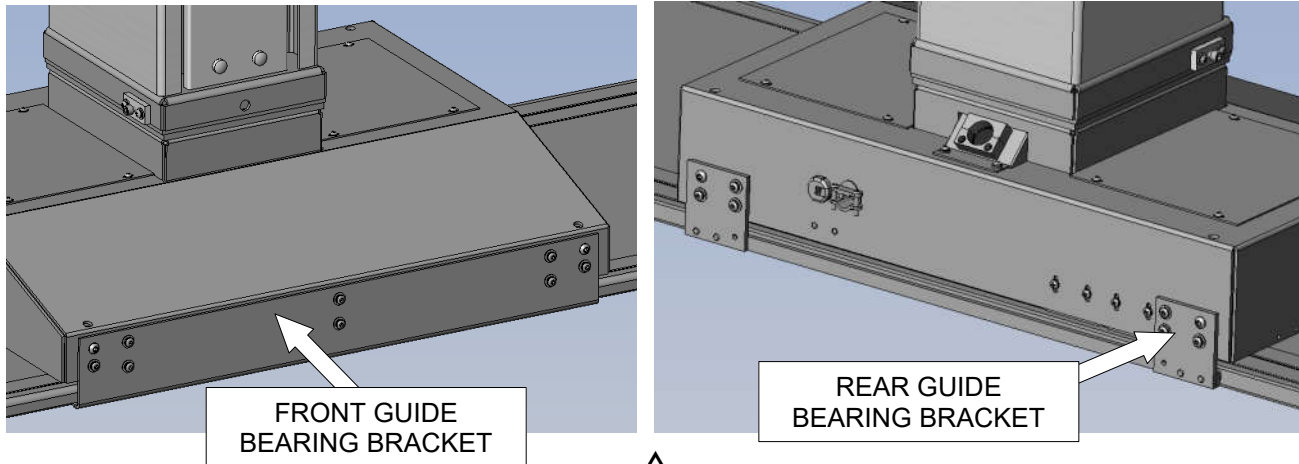

WARNING

THE COLUMN ASSEMBLY WEIGHS ABOUT 340 LBS. IT WILL REQUIRE ADDITIONAL PERSONNEL OR A MECHANICAL LIFTING DEVICE TO SAFELY LIFT AND POSITION ON THE FLOOR RAIL

The sloped side of the floor car faces the front edge of the floor rail. Lift the column and place on top of the floor rail, aligning the floor car main bearings atop the hardened steel bearing tracks of the floor rail.

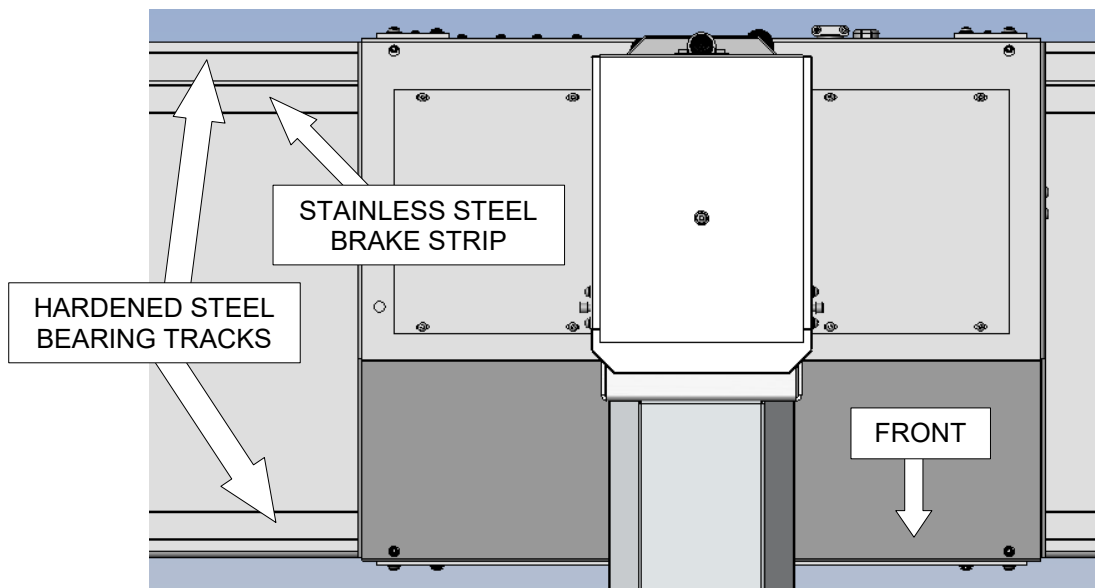

Once the column assembly is near the correct location, reinstall the front and rear guide bearing brackets. The rear brackets can be assembled directly from the rear. To install the front bracket, remove one of the front floor car travel stops (left shown below). Slide the front guide bearing bracket into the channel from the end and slide

down the rail to align with the mounting holes on the floor car. Reinstall all the hardware. Remember to reinstall the front floor car travel stop.

Once both guide bearing brackets are properly installed roll the column assembly back and forth along the entire floor rail to verify smooth movement.

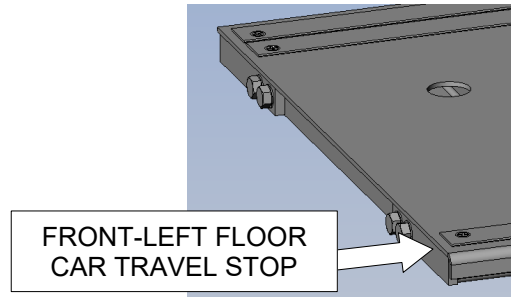

NOTE

*The hardened steel bearing tracks on the floor rail must have a thin film of oil to resist corrosion. They are shipped oiled from the factory however if insufficient oil remains after installation reapply. **DO NOT** apply oil to the stainless steel brake strip.*

3.3 Mount the X-ray Tube and Collimator

In all applications the tube anode should be up when the tube is aimed at the wallstand. This is conventionally done due to the x-ray tube heel effect.

Read the collimator manufacturer's instructions before installing. The number of spacers required will vary depending on the x-ray tube and collimator. The proper tube focal spot to collimator mounting surface dimension will be given by the collimator manufacturer.

The platform or trunnion ring assembly is factory-mounted to the transverse arm. For all mount types, be sure that the lock and potentiometer cables do not get trapped/pinched between the tube port surface and the mounting plate.



NOTE

Be sure to use the proper screws to mount the x-ray tube. Refer to the tube manufacturer's installation instructions on mounting bolt requirements.



WARNING

ENSURE THAT THE PLATFORM BRACKET DOES NOT ROTATE BEFORE THE SCREWS ARE IN PLACE AS THE X-RAY TUBE CAN FALL

For **platform mount** place the tube on top, collimator ring on bottom, and secure with the proper screws. Place spacer(s) between the platform bracket and the collimator mounting ring.

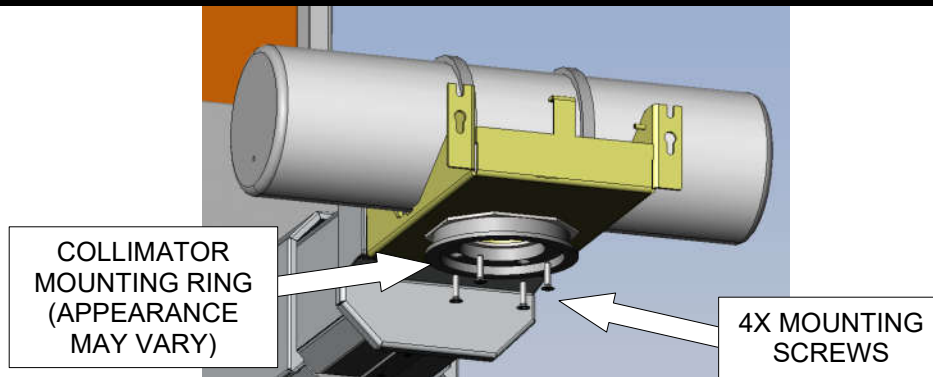

For trunnion mount, open trunnion ring assembly by removing the lock handle. The upper ring assembly opens via the hinges. Place the tube in lower cradle, close, and replace lock handle. Place the angulation bracket and spacer(s) between the x-ray tube port and the collimator mounting ring.

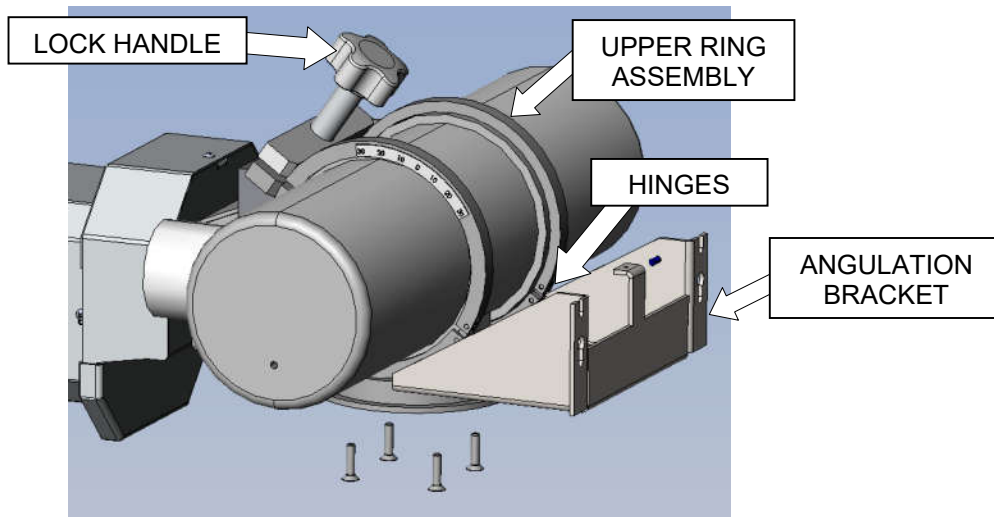

For all installations now assemble the collimator per the manufacturer's instructions. Connect the collimator cable (shipped with the collimator) according to designations on the cable conductors.

3.4 Install the Angulation Box

Install the angulation box to the mounting plate using the hardware provided.

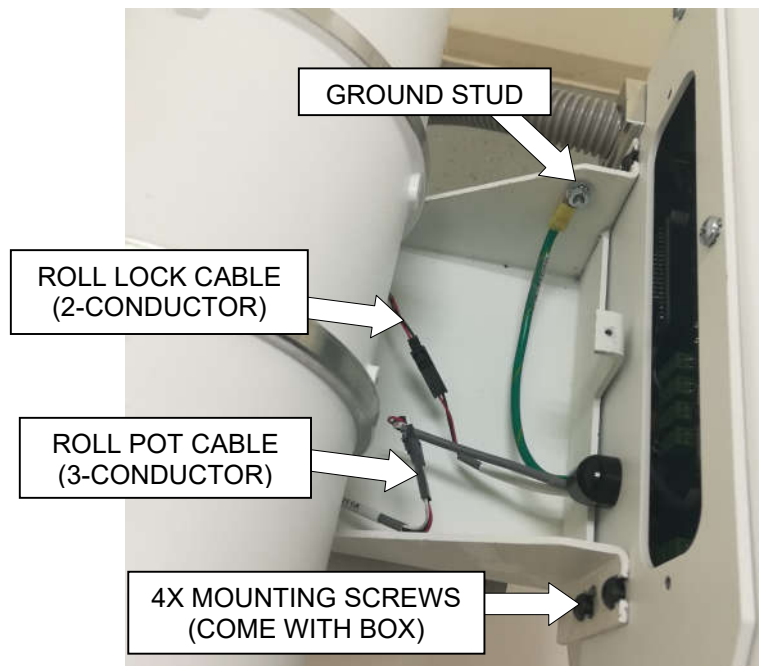

If necessary insert the roll lock and pot cables under the tube housing beside the port. Connect the roll lock cable (2-conductor) and roll pot cable (3-conductor) to the angulation box. Connect the ground cable to the stud on angulation box mount using the nut provided there.

3.5 Install the High Voltage Cables

Install the high voltage cables by following the manufacturer’s instructions. Install the tube stator cable at this time, routing it with the high voltage cables.

4. TUBESTAND LEVELING AND ADJUSTMENT

Leveling and adjustment of the tubestand are critical to achieving an aligned system. Once the tubestand is properly assembled and adjusted the remaining system component locations (such as table and wallstand) can be finalized.

4.1 Trim the Counterweight

Check the balance of the system by moving the arm to around the middle of its vertical travel and releasing the lock. If the arm drifts down add trim weights (included). If the arm drifts up, there are too many trim weights—remove some. Remove the access panel on the upper rear of the column. Add or remove trim weights to the trim weight compartments of the main counterweight. Distribute final quantity evenly between the two compartments.

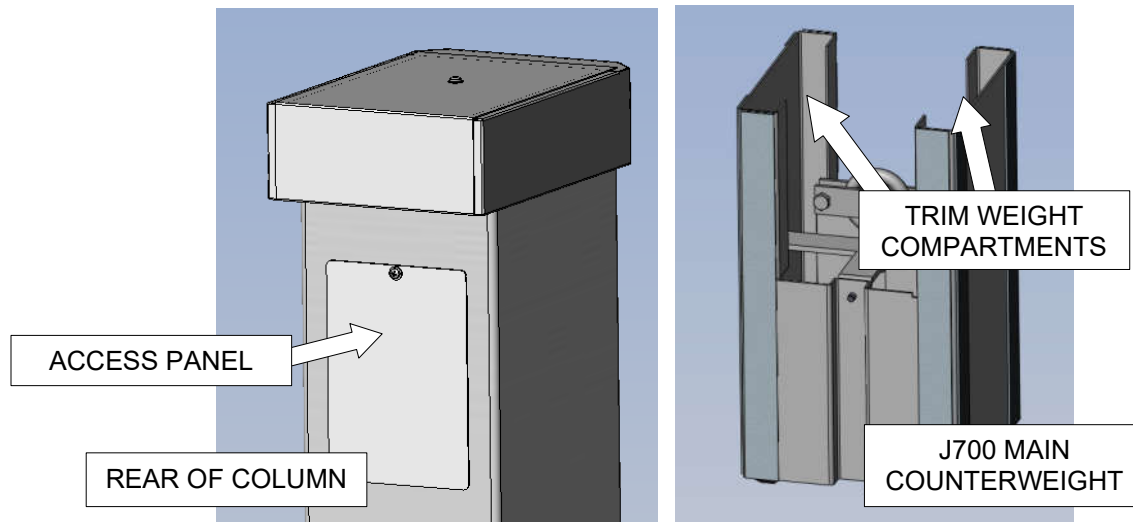

4.2 Column Leveling

The final leveling of the column should be done after the tube, cables and collimator are installed.

The floor car is factory set to be level and the column is verified to be vertical. If your column is not vertical, *first verify that the floor rail is level* in both directions before adjusting the floor car. If necessary use shims provided to level the floor rail.

Place a level vertically on the column, alternating between the front and one side. Level it to vertical in both directions by adjusting the eccentric load bearings in the two rear corners of the floor car. Access these by removing the floor car top covers.

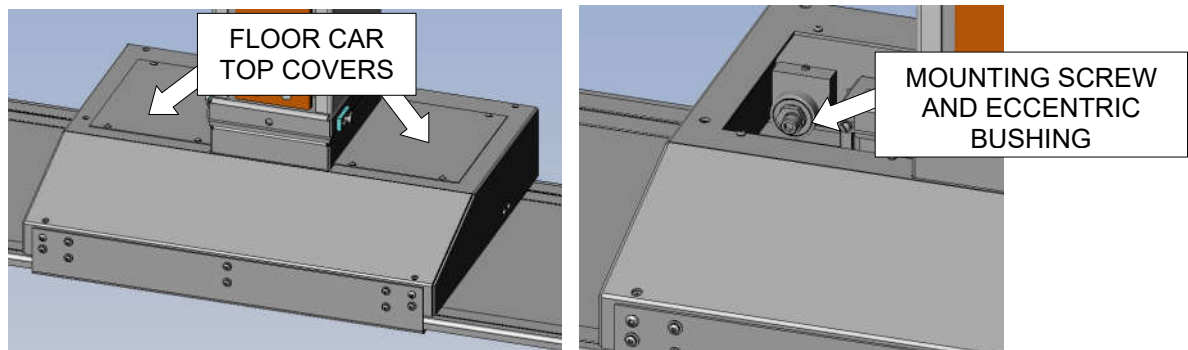

Loosen the mounting screws on both sides and adjust the eccentric bushings until the column is vertical. Verify that the column remains vertical throughout its travel on the floor rail.

4.3 Transverse Arm Leveling

The transverse arm has been leveled at the factory. If adjustment is necessary after tubestand assembly perform the following.

Remove the four attachment screws from the lower corners and lift to remove the upper rear arm cover.

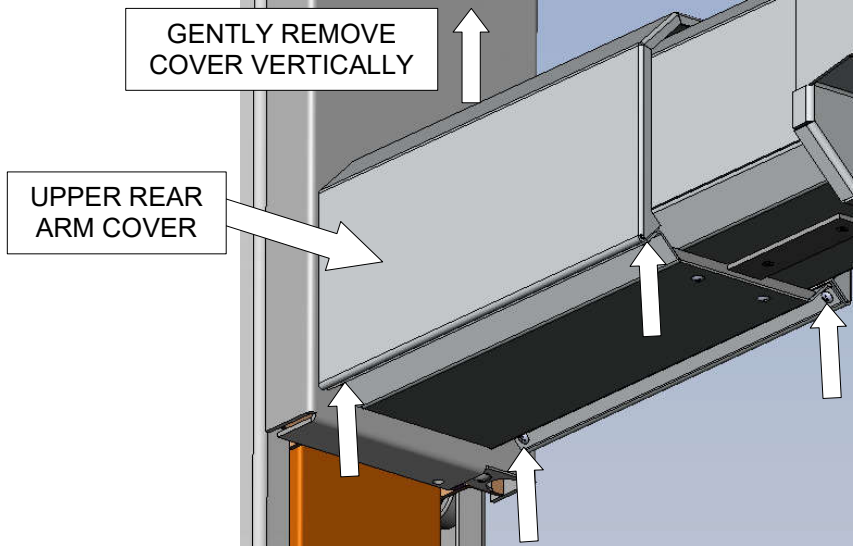

Remove the front cover screws (two each side) and the (upper and lower) front covers.

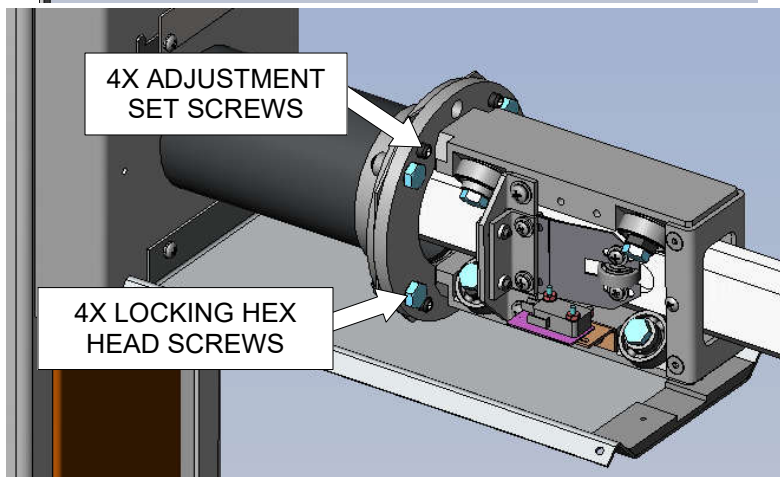
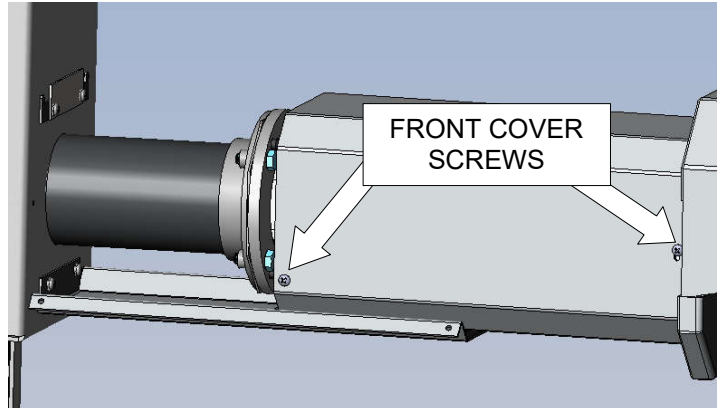

Loosen all four locking hex head screws to make adjustments

Tighten the lower adjustment set screws to raise the arm (centerline moves out).

Tighten the upper adjustment set screws to lower the arm (centerline moves in)

Tighten the left adjustment screws to move the head to the right (shoot left: centerline moves out; shoot right: in)
 Tighten the right adjustment screws to move the head to the left (shoot left: centerline moves in; shoot right: out)
 Retighten the four locking hex head screws when adjustments are completed.

4.4 Align the Collimator Light Source to the X-Ray Field

Verify that the x-ray field and light field are coincident. Refer to the collimator manual for details on adjusting the light field to match the x-ray field.

5. FINAL ASSEMBLY ITEMS

5.1 Connect the Table Vertical Potentiometer

If the system was ordered with a non-elevating table, remove the potentiometer cable from the floor car and skip this step.

For systems with an elevating table connect the table potentiometer cable from the floor car to the vertical pot in the table. The potentiometer connector exits the rear of the table in the center, near the floor.

5.2 Install the Horizontal SID Actuators (for SID Switches)

The Horizontal SID Switches are factory-assembled inside the floor car along the right side. The 40" SID switch is closest to the front and the 72" switch is closest to the rear of the floor car.

Measure to set the x-ray focal spot to the image plane of the wallstand at 40" (SID). Mark the floor rail under the front switch roller. Next measure and set the SID to 72", marking the floor rail under the rear switch roller.

Apply an aluminum actuator ramp (included) to each marked location on the floor rail. Verify that each is aligned with its appropriate switch.

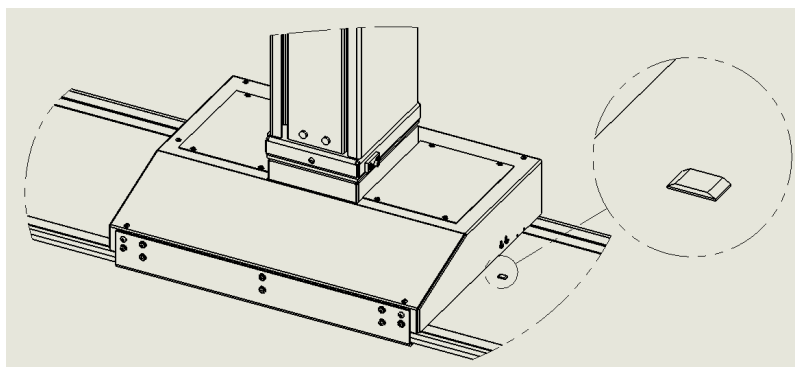
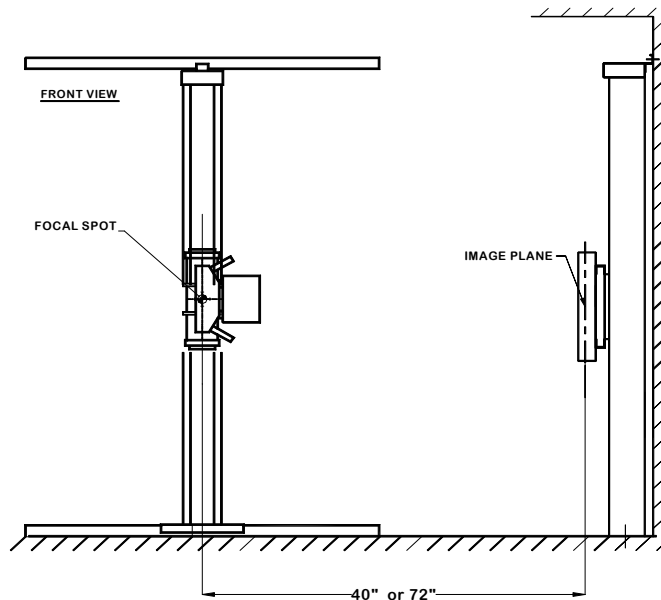

5.3 Horizontal SID labeling

As a failsafe the horizontal SID labels should be installed. Fasten the pointer bracket to the right side of the floor car using the two #4-40x3/8 screws & TOOTH WASHERS included.

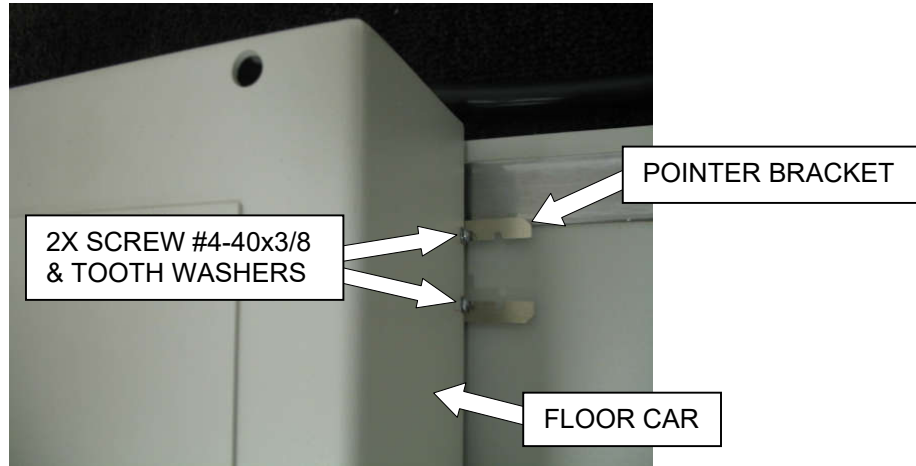

Apply the 40 and 72 labels to the floor track to align with the pointer bracket where the SID switches are actuated.

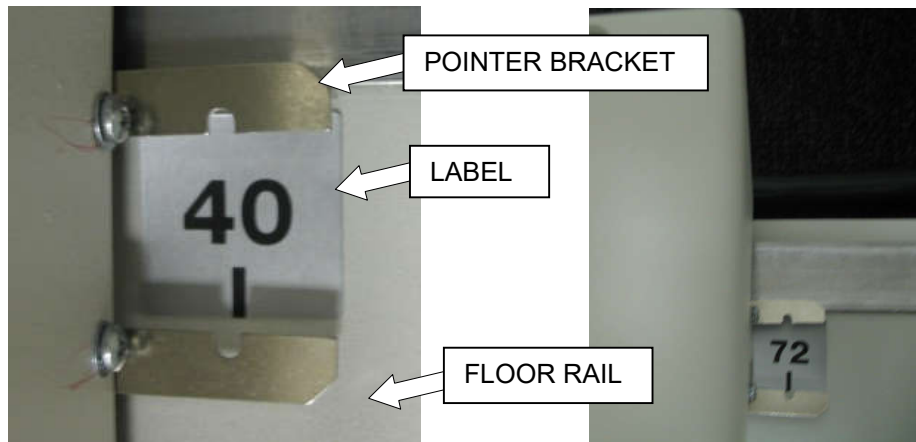

5.4 Install the Cable Sleeve Kit

A cable sleeve cover kit is included with the DFMT. Follow the instructions included with the kit.



6. CALIBRATION



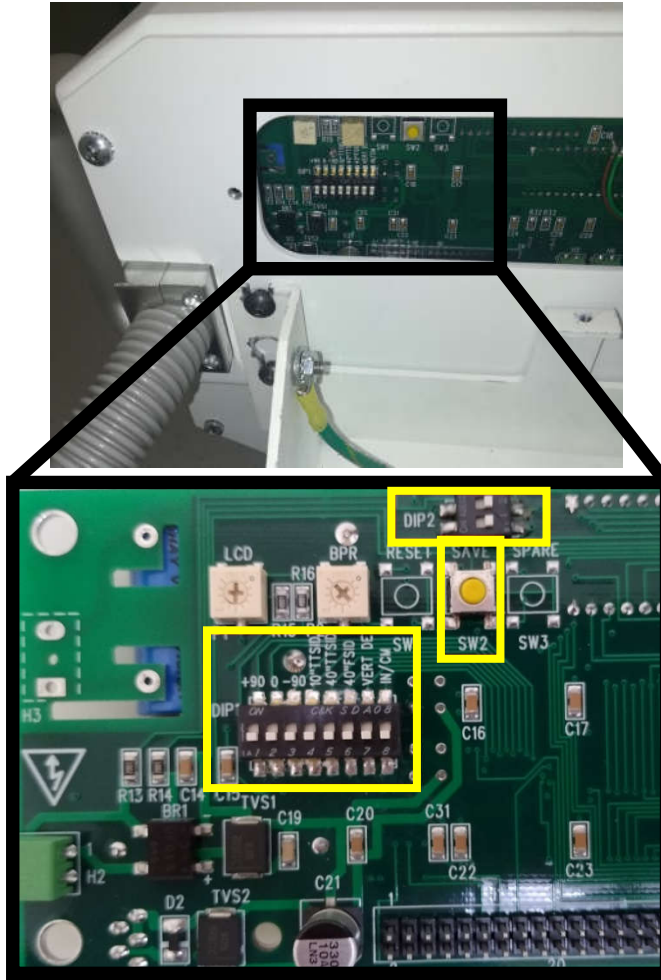



Remove the rear access cover of the angulation box. Table must be powered on and table pot (If present) connected to tubestand before initial power up. Perform all configuration and calibration steps in the order that they are presented.



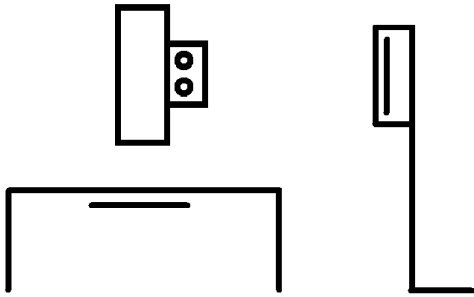
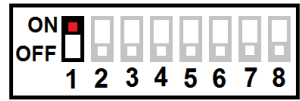

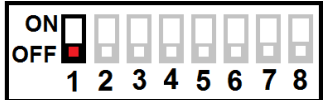
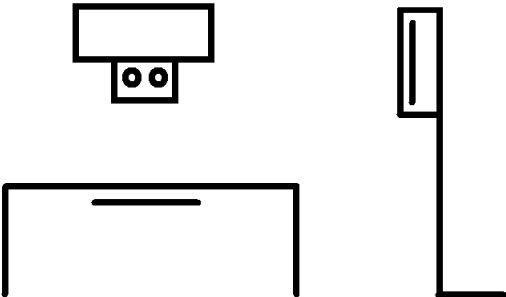
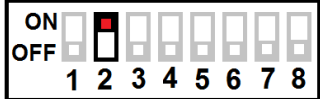

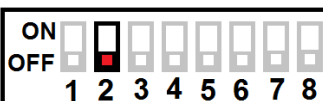
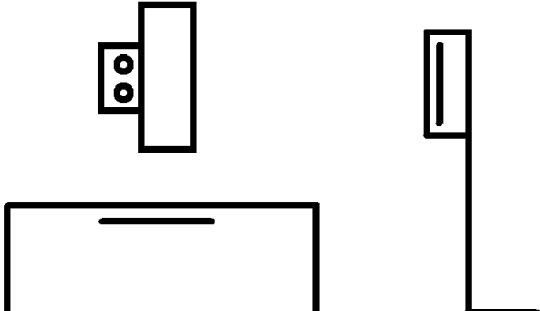
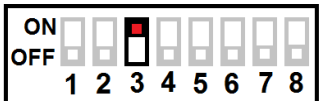

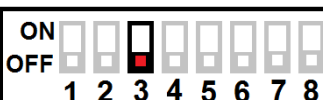
Location of DIP1 DIP2, and SAVE button

6.1 Feature Configuration	
DISPLAYED UNITS DIP1-8	<div style="display: flex; justify-content: space-around;"> <div style="text-align: center;"> INCHES </div> <div style="text-align: center;"> CENTEMETERS </div> </div>
LCD BACKGROUND REVERSAL DIP2-1	<p><u>Procedure:</u></p> <ul style="list-style-type: none"> • Turn off tubestand • Switch DIP to configuration • Turn on Tubestand <div style="display: flex; justify-content: space-around;"> <div style="text-align: center;"> NORMAL </div> <div style="text-align: center;"> REVERSE </div> </div> <p style="text-align: center;">Default: NORMAL</p>
ANGULATION TYPE DIP2-2 Relative (+90/-90 will display as 0 deg)	<div style="display: flex; justify-content: space-around;"> <div style="text-align: center;"> RELATIVE </div> <div style="text-align: center;"> ABSOLUTE </div> </div> <p style="text-align: center;">Default: RELATIVE</p>

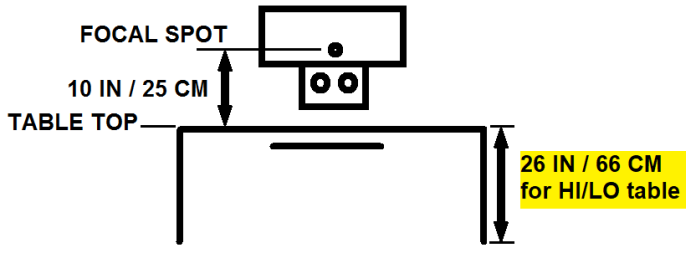
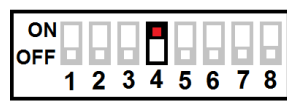

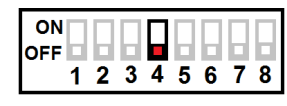
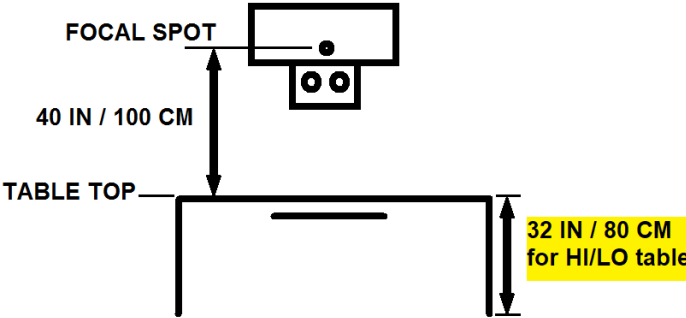
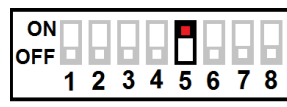

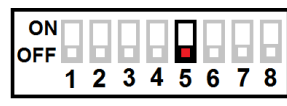
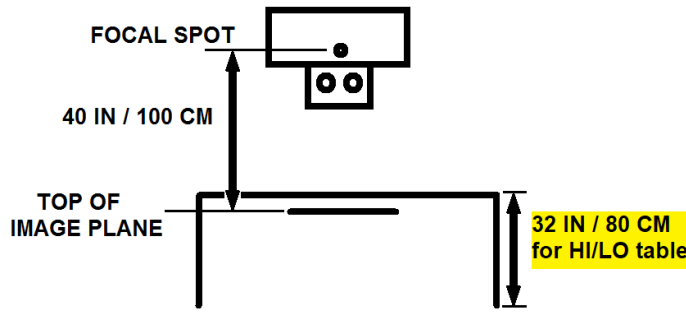
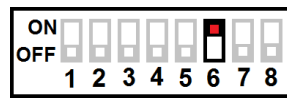
6.2 Tube Angle Calibration (*Proceed in the order below*)

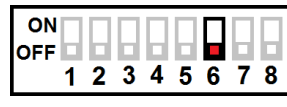
CAL TYPE	COMPONENT SETUP	SAVING PROCEDURE (DIP1)
<p>ANGLE +90 TOWARD WALL STAND</p>	 <p>Note: When in default configuration, display will show 0° when turned towards wallstand.</p>	<p>1 </p> <p>2 </p> <p>3 </p>
<p>ANGLE 0</p>		<p>1 </p> <p>2 </p> <p>3 </p>
<p>ANGLE -90 AWAY FROM WALL STAND</p>	 <p>Note: When in default configuration, display will show 0° when turned away from wallstand.</p>	<p>1 </p> <p>2 </p> <p>3 </p>

6.3 Vertical SID Calibration (Proceed in the order below)

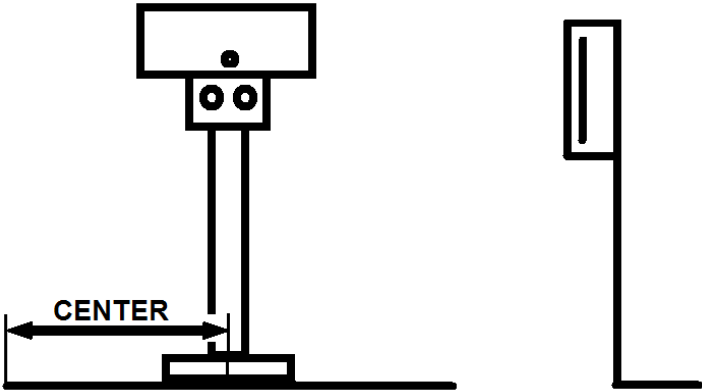
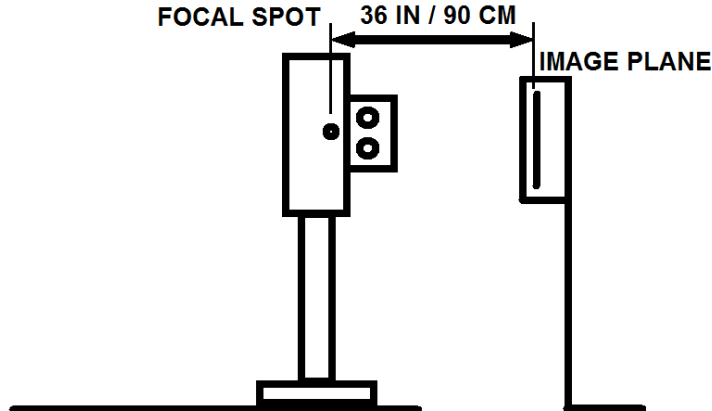
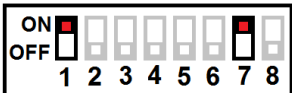
CAL TYPE	COMPONENT SETUP	SAVING PROCEDURE (DIP1)
<p>SID TABLE TOP 10 IN</p>		<p>1 </p> <p>2 </p> <p>3 </p>
<p>SID TABLE TOP 40 IN</p>		<p>1 </p> <p>2 </p> <p>3 </p>
<p>SID IMAGE PLANE</p>		<p>1 </p> <p>2 </p> <p>3 </p>

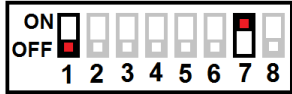
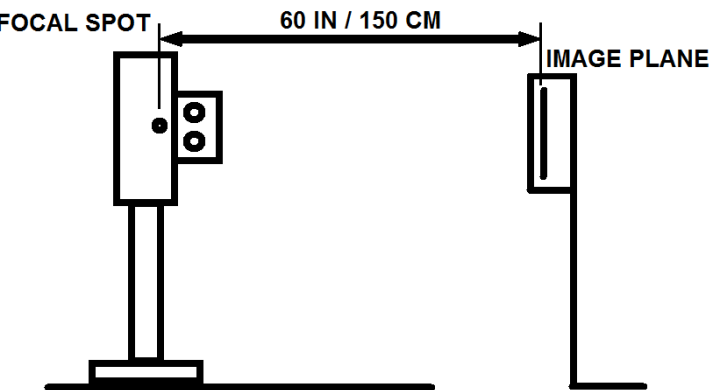
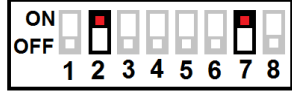
6.4 Horizontal SID Calibration (Proceed in the order below. HSID section on page 11 must be followed)

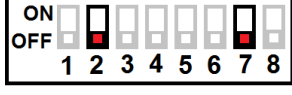
CAL TYPE	COMPONENT SETUP	SAVING PROCEDURE (DIP1)
CENTER		<ol style="list-style-type: none"> 1 ENTER HORZ SID CAL MODE (Press the top four buttons at the same time) 2 ADJUST HORZ SID WHEEL UNTIL DISPLAY INDICATES: 2.14 – 2.18 VOLTS DC (Long beep sounds when proper voltage achieved) 3 REMOVE SHIPPING SCREW (see Section 6.5) 4 EXIT HORZ CAL MODE 5 ROTATE TUBE TO WALLSTAND 6 Needed for recalibration of the system – SKIP this step for initial / installation calibration. MOVE TS TO 72 SID
36 IN SID		<ol style="list-style-type: none"> 1  2  3 
60 IN SID		<ol style="list-style-type: none"> 1  2  3 

6.5 Engage the Horizontal SID Assembly

Move the column assembly to the middle of the floor rail. When in position, hold the arm of the assembly, remove the shipping screw, and gently lower the wheel to the floor rail surface.

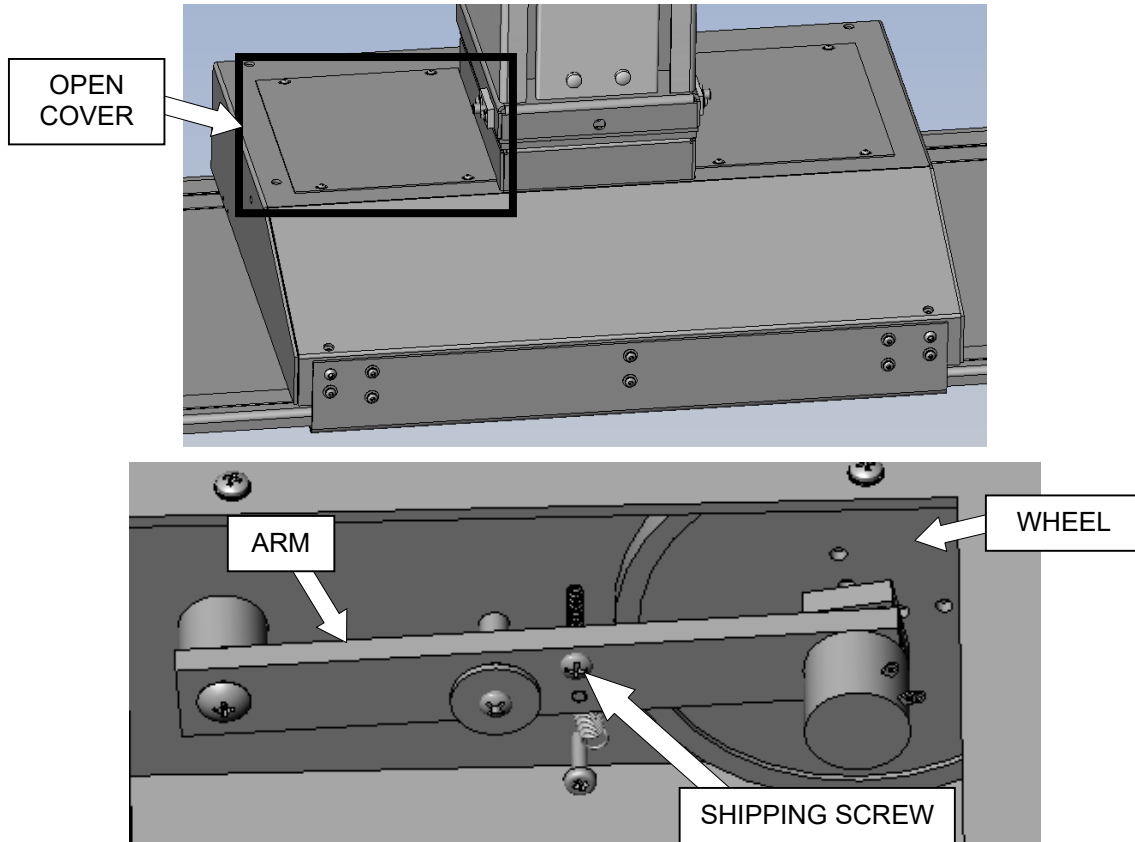

View forward from rear of floor car

7. RECOMMENDED MAINTENANCE

The following scheduled maintenance is required for safety of operation, continued ease of use, and continued long life of the product.

The maintenance program should be performed only by qualified and authorized service personnel. Frequency of the service should be 30 days after installation and annually thereafter unless indicated otherwise by local codes and regulations.

7.1 Tubestand

Inspect counterweight cables for fraying, damage, or wear. Check compression sleeves and eyelets for damage or wear. Check that pulleys and pulley mounts are secure and undamaged. Check that all cable attachment points are secure.



WARNING

INSPECTION AND MAINTENANCE OF THE ENTIRE COUNTERWEIGHT CABLE SYSTEM IS CRITICAL FOR CONTINUED SAFE OPERATION

Thoroughly clean the stainless steel brake strip (see figure in 3.2.2).

Thoroughly clean the two hardened steel bearing tracks (see figure in 3.2.2). Following cleaning apply a protective film of oil to each. **DO NOT** oil the stainless steel brake strip.

Clean the Horizontal SID assembly wheel and the entire strip of the floor rail on which it rides. Following cleaning re-calibrate the Horizontal SID assembly (see Section 6 CALIBRATION)

Check alignment (x-ray beam to film or receptor).

Inspect all tubestand movements for binding or interference, check all bearings for proper operation.

Check all fasteners for tightness including the floor rail fasteners and tubearm screws.

Verify the travel stops are in good, functional condition.

Verify that all the locks are working properly.

Check all SID displays and markers.

Inspect cabling/wiring for damage.

7.2 Collimator

Verify accuracy of field size knob indication to actual x-ray field size.

Verify accuracy of light field to x-ray field alignment.

Check lamp ON time / auto OFF function.

Inspect collimator cable for fraying or damage.

Refer to the collimator manual for other recommended maintenance.

7.3 X-Ray Tube

Inspect the housing for possible oil leakage.

Assure that the housing is tightly fastened to the tube mount and collimator.

Inspect stator cable for fraying or damage.

Inspect high voltage cable ends for carbon tracking. Clean and re-grease HV Cable ends annually.

Refer to the x-ray tube manufacturer for other recommended maintenance.

8. DIAGNOSTICS

The junction box PCB features an MDI (Meterless Diagnostic Interface).

The following error codes will be displayed on the **PCB** and the **angulation box LCD** in response to a failure:

8.1 Error Code Table

ERR. CODE	LED	DESCRIPTION
	1 2 3 4	
E01-TS	□□□■	ROLL LOCK SHORT
E02-TS	□□■□	VERTICAL LOCK SHORT
E03-TS	□□■■■	LONGITUDINAL LOCK SHORT
E04-TS	□■■□□	TRANSVERSE LOCK SHORT
E05-TS	□■■□■	ROLL LOCK OPEN
E06-TS	□■■■□	VERTICAL LOCK OPEN
E07-TS	□■■■■	LONGITUDINAL LOCK OPEN
E08-TS	■□□□	TRANSVERSE LOCK OPEN
E09-TS	■□□■	JUNCTION BOX PCB, Q17 SHORT
E10-TS	■□■□	JUNCTION BOX PCB, Q3 SHORT
E11-TS	■□■■■	JUNCTION BOX PCB, Q21 SHORT
E12-TS	■■■□□	JUNCTION BOX PCB, Q27 SHORT
E13-TS	■■■□■	POWER SUPPLY, 24V OUT OF RANGE
E16-TS	□□□□	ALL LOCK BUTTON
E17-TS	①□□■	ROLL LOCK BUTTON
E18-TS	①□■□	VERTICAL LOCK BUTTON
E19-TS	①□■■■	LONGITUDINAL LOCK BUTTON
E20-TS	①■■□□	TRANSVERSE LOCK BUTTON
E21-TS	①■■□■	ROLL POT
E22-TS	①■■■□	VERTICAL POT
E23-TS	①■■■■	HSID POT
E24-TS	②□□□	TABLE POT
<u>KEY</u>		
□ LED OFF		① BLINK ONCE
■ LED ON		② BLINK TWICE

8.2 Error Code Locations

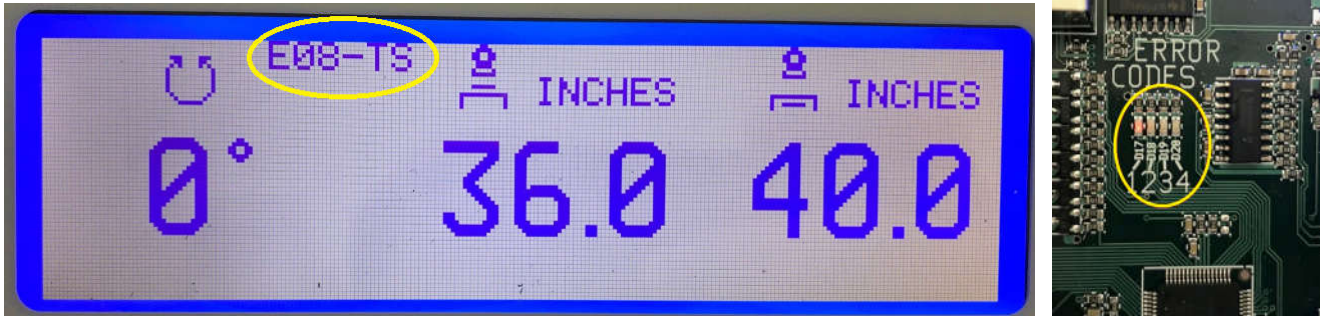

8.3 Error Codes of Angulation Box Button LEDs

During an error, the angulation box lock button LEDs will blink with the following patterns:

ERROR	LOCK BUTTON LEDs	BLINK TIMES
E01-TS	ROLL	BLINK 1 TIME
E02-TS	VERTICAL	BLINK 1 TIME
E03-TS	LONGITUDINAL	BLINK 1 TIME
E04-TS	TRANSVERSE	BLINK 1 TIME
E05-TS	ROLL	BLINK 2 TIMES
E06-TS	VERTICAL	BLINK 2 TIMES
E07-TS	LONGITUDINAL	BLINK 2 TIMES
E08-TS	TRANSVERSE	BLINK 2 TIMES
E09-TS	ROLL	BLINK 3 TIMES
E10-TS	VERTICAL	BLINK 3 TIMES
E11-TS	LONGITUDINAL	BLINK 3 TIMES
D12-TS	TRANSVERSE	BLINK 3 TIMES
E13-TS	ALL	BLINK 1 TIME
E16-TS	ALL	LED is OFF
E17-TS	ROLL	LED is OFF
E18-TS	VERTICAL	LED is OFF
E19-TS	LONGITUDINAL	LED is OFF
E20-TS	TRANSVERSE	LED is OFF

8.4 Error Codes of Angulation Box LCD

ERROR	DESCRIPTION	RESOLUTION
DIP-ERROR	Bad CAL Switch selection at DIP1	Select the correct DIP1
ERROR: MEMORY CORRUPT UNIT REQUIRES RECALIBRATION	Blank EEPROM or Corrupted Data	Press & hold SAVE button at power up to burn Factory Defaults
ERROR, NO CALIBRATION SETPOINT CHOSEN, NOTHING SAVED!	Save button pressed without proper DIP1 setting	Set the correct DIP1

8.5 Fuses

Fuse Values:

F1-F2 = 800 mA, 250 V, SLO-BLO, 3AB/3AG

F3-F6 = 400 mA, 250 V, SLO-BLO, 3AB/3AG

Fuses are located in the right side of floor car as shown below.

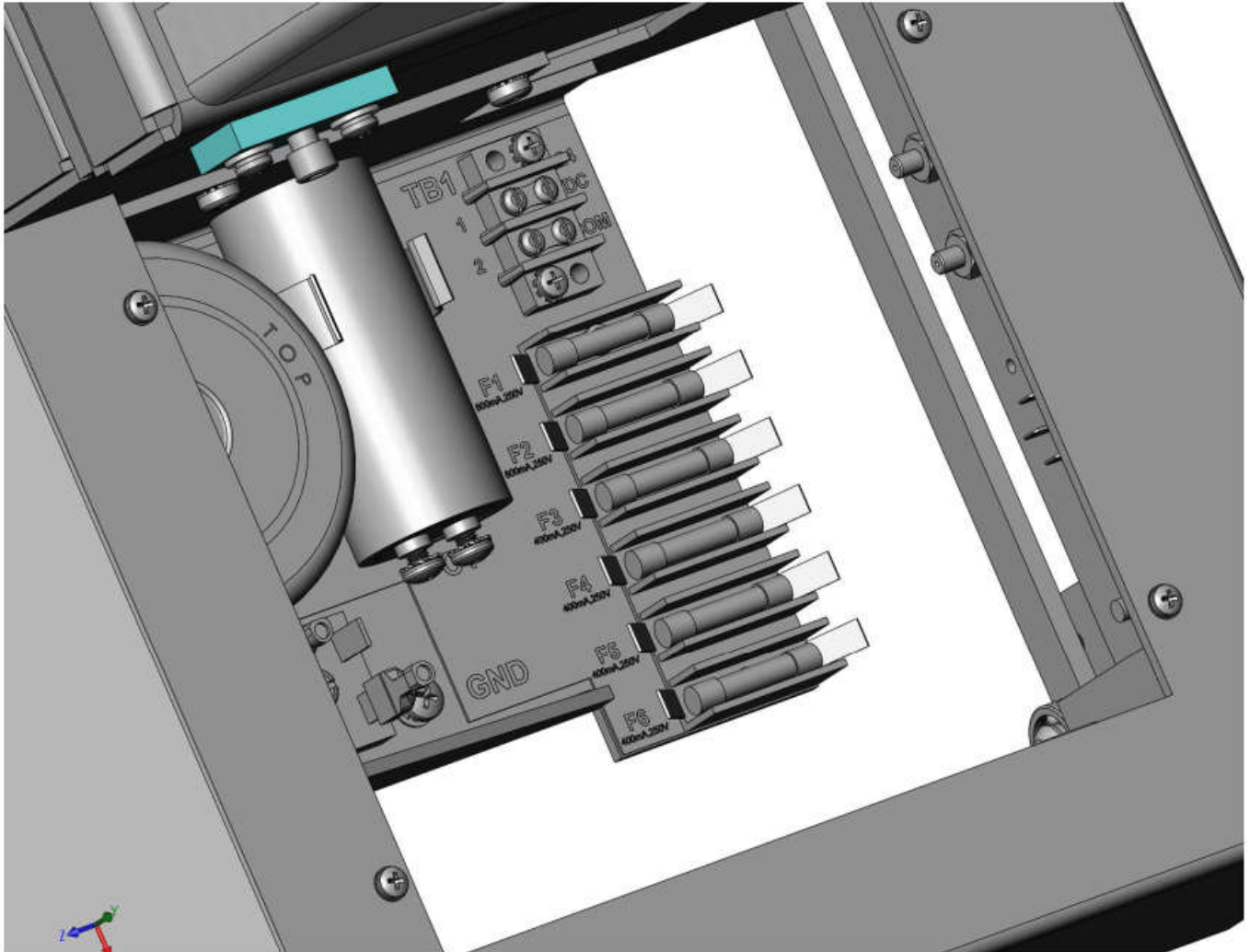





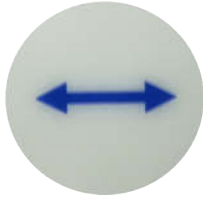

9. DFMT OPERATION

9.1 Buttons and Display Indicators





Buttons

Symbol or photo	Name	Description
	Longitudinal Lock Release	Depress this button to release only the longitudinal lock and move the tubestand horizontally. Release to lock. With the tube facing the wallstand Horizontal SID is displayed in the LCD display window. Longitudinal and vertical lock buttons swap function between beam vertical and horizontal to keep arrows pointing in the direction of operation.
	Transverse Lock Release	Depress this button to release only the transverse lock and move the tube in and out. Release to lock.
	All Lock Release	Depress this button to release all electromagnetic locks that secure all Tube Stand motions (except the "ROLL" motion). The x-ray tube may now be moved in any direction, including vertical. Release the switch to re-engage all locks.
	Roll Lock Release	Roll is rotation of the tube about the arm axis. Depress the button to release the lock and roll the x-ray tube to the desired position. Mechanical detents are provided at 0° and at 90° increments. Release to lock. The roll angle is displayed in the LCD display window. See Section 9.3 Typical Displays.

	<p>Vertical Lock Release</p>	<p>Depress this button to release only the vertical lock and move the tube up or down. Release to lock.</p> <p>Longitudinal and vertical lock buttons swap function between beam vertical and horizontal to keep arrows pointing in the direction of operation.</p>
	<p>One Hand Multi-Lock Release</p>	<p>Grasping the center handle while pushing the button releases all electromagnetic tubestand locks except the roll lock. Release the center handle to re-engage the locks.</p> <p>Automatic SID lock activation is not functional when using this button.</p>

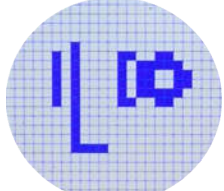
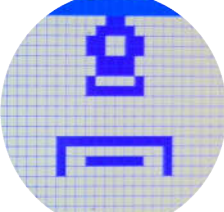
Display Indicators

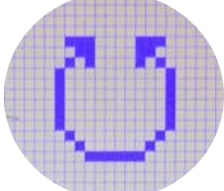
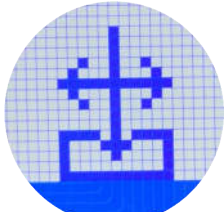
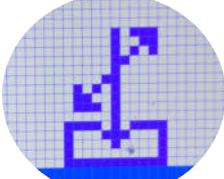
	<p>Horizontal SID</p>	<p>With beam horizontal the number displayed below this symbol is the horizontal SID (Source to Image Distance).</p>
	<p>Vertical SID</p>	<p>With beam vertical the number displayed below this symbol is source to the table receptor image plane.</p>
	<p>Vertical SID (Tabletop)</p>	<p>With beam vertical the number displayed below this symbol is source to the tabletop plane.</p>
	<p>Tube Angle</p>	<p>With beam vertical or horizontal the number displayed below this symbol is the tube angle.</p>
	<p>Longitudinal Detent Indicator</p>	<p>With tube horizontal this indicator shows when the x-ray tube is positioned at one of the two longitudinal SID detents.</p> <p>The longitudinal locks activate automatically for 2 seconds to stop the column at the SID detent location. Automatic lock activation is speed-dependent, only functioning at slow movement speed (<3 in/sec). Automatic lock activation functions ONLY when using longitudinal lock button.</p>
	<p>Transverse Detent Indicator</p>	<p>With tube vertical or horizontal this indicator shows when the x-ray tube is positioned in the transverse detent. There is only one transverse detent location.</p> <p>The transverse detent is mechanical.</p>

9.2 Other Features

Column Rotation

The column is designed to rotate about its vertical axis so that the arm is parallel to the floor rail. There are detent locations 90° apart.



CAUTION

TO PREVENT TUBE DRIFT AND POTENTIALLY UNUSABLE RADIOGRAPH, ALWAYS PERFORM EXPOSURES IN ONE OF THE 90° COLUMN DETENT POSITIONS

Tube Trunnion Mount

Trunnion rings allow the x-ray tube to rotate about its horizontal (long) axis. To do this, loosen the lock knob. Set the angle using the scale mounted on the trunnion ring assembly. Re-tighten the lock knob.

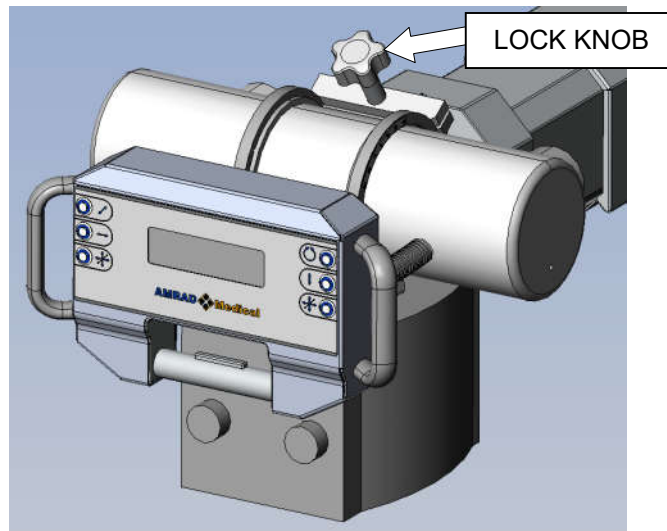

CAUTION

TO PREVENT TUBE DRIFT AND POTENTIALLY AN UNUSABLE RADIOGRAPH, ALWAYS LOCK THE TRUNNION ASSEMBLY BEFORE TAKING AN EXPOSURE

9.3 Typical Displays (product configured for inches)

Beam Vertical (X-ray tube directed downward)

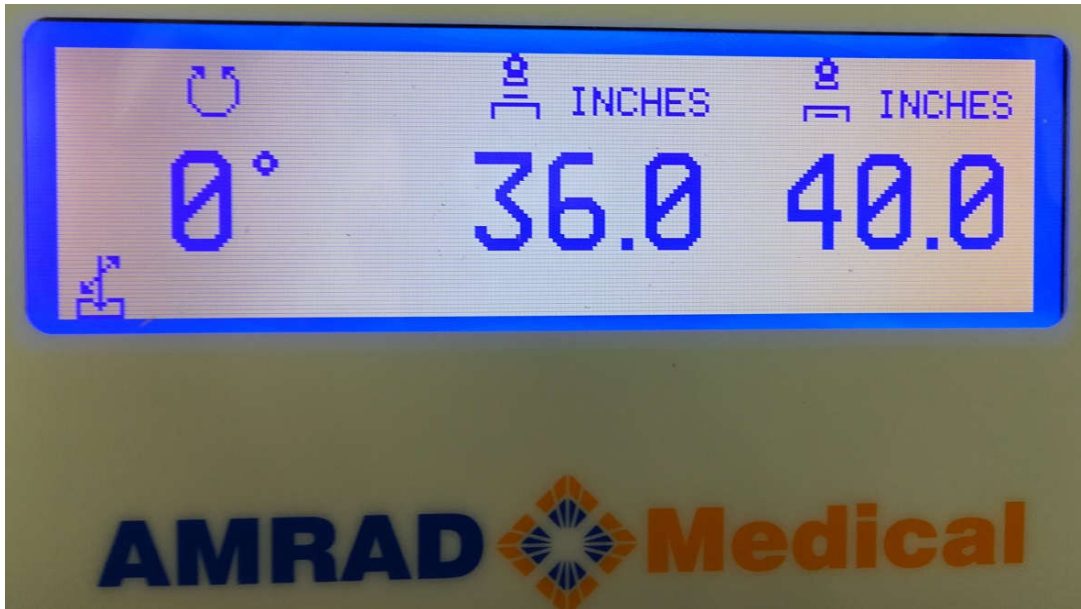

Beam vertical at 0°, 36.0 in to the tabletop plane, 40.0 in to the table receptor image plane. SID values may be set to cm as an option (see section 6.1 Feature Configuration).

Tube at the transverse detent position.

Beam Horizontal (X-ray tube directed to the side)

A vertical digital display with a blue border. On the left side, the 'AMRAD Medical' logo is oriented vertically. The display shows a circular refresh icon at the top, followed by '0°'. Below that is 'INCHES' with a small X-ray tube icon to its left, and the number '40.0'. At the bottom, it says '40 IN' with a small X-ray tube icon.	A vertical digital display with a blue border. On the left side, the 'AMRAD Medical' logo is oriented vertically. The display shows a circular refresh icon at the top, followed by '0°'. Below that is 'INCHES' with a small X-ray tube icon to its left, and the number '72.0'. At the bottom, it says '72 IN' with a small X-ray tube icon.
<p>Beam horizontal at 0°, locked at the 40 in horizontal SID detent position, tube at the transverse detent position</p>	<p>Beam horizontal at 0°, locked at the 72 in horizontal SID detent position</p>