



PREFACE

Agility



Mobile C-arm unit for fluoroscopy and radiography

Distributed by:



7555 N. Caldwell Ave.
Niles, Illinois 60714
800-729-9729
773-353-4000



CAUTION:
Read all the enclosed documents before using the EM equipment

Part 0 : **PREFACE**

CONTENTS

	pages	rev.	date
1 DESCRIPTION OF THE EQUIPMENT	1 to 5	0	01/03/21
2 IDENTIFICATION / SERIAL NUMBERS			
3 LIABILITY STATEMENT			
4 CONFORMITY AND REFERENCE ADDRESS			

1 DESCRIPTION OF THE EQUIPMENT

Agility is a mobile X-ray device used for radiological guidance and visualization during diagnostic, interventional and surgical procedures.

Agility is used for X-Ray controls in orthopaedic and general surgeries, pace-maker implantation, electrophysiology, pain therapy, urology, x-ray controls in lithotripsy therapy, gastro interventional procedures, thorax surgeries, peripheral vascular interventional with DSA technique. RX only.

Note: *This EM equipment is not suitable for vascular diagnosis.*

The equipment comes in the following models:

	Name of Model	REF	Max X-ray Generator power	Flat panel detector	Monitor Layout
1	Agility	SR21	5kW	aSi 21x21 cm ²	Landscape 27"
2	Agility	SR30	5kW	aSi 30x30 cm ²	Landscape 27"

Table 1

Optional:

- DICOM functions,
- DSA functions.

2 IDENTIFICATION / SERIAL NUMBERS

The equipment is identified by label A.
 The individual components are also labelled:
 - B: X-ray monoblock
 - C: Flat Panel Detector ⁽¹⁾
 - D: Monitor⁽²⁾

Note (1) : Label only accessible after removing the detector carter.

Note (2) : Label only accessible after removing the monitor carter.

The positions of these labels are indicated in the figures below:

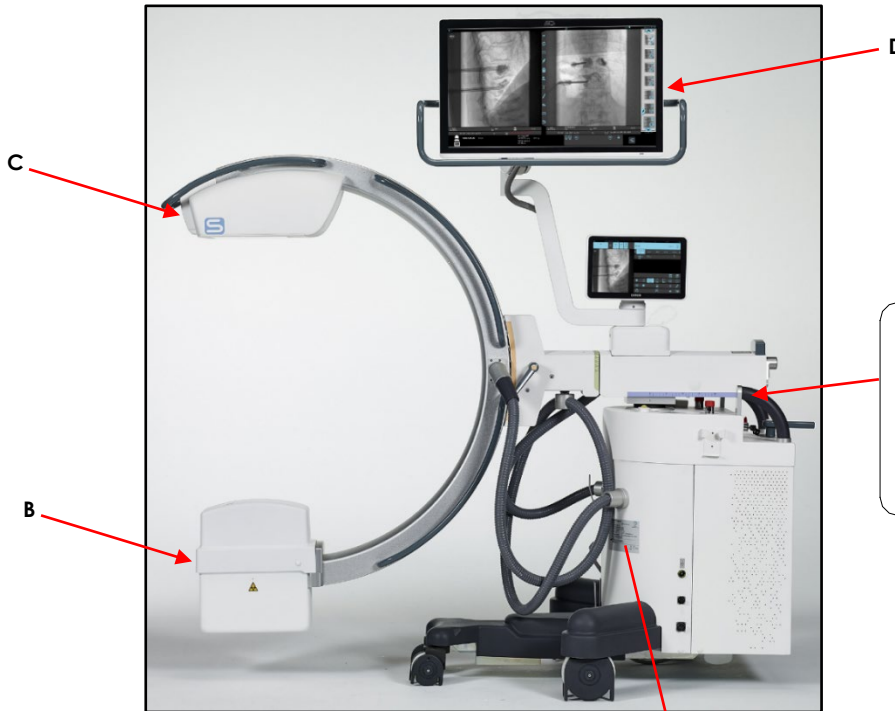

Warning
 This x-ray unit may be dangerous to patient and operator unless safe exposure factors, operating instructions and maintenance schedules are observed.

<p>Model: Agility</p> <p>XXXXXX-XXXX</p> <p>REF XXXX</p> <p>code XX XX XXX</p> <p>XXX ~ Vac / 50/60 Hz</p> <p>XX A max: Fluoroscopy modality</p> <p>22A max: Radiography modality</p> <p>Apparent resistance : 0,4 ohm</p> <p>Circuit breaker : In=XXA - Characteristic=D</p> <p>Physiological effects : ionising radiation Max 120 kV</p> <p> ≥ 3mm Al eq. @70kV</p> <p>Distributed by Summit Industries, LLC</p> <p> Applicazione Tecnologie Speciali s.r.l. Via A. Volta, 10 - 24060 Torre de' Roveri (BG) ITALY http://www.atmed.it</p>	<p>Barcode</p> <p>(01) 8055 186670XXX</p> <p>(11) XXXXXX</p> <p>(21) XX XXX 95 XX</p> <p>Caution: Federal law restricts this device to sale by or on the order of a physician.</p> <p>This product conforms to DHHS radiation standards of 21CFR subchapter J as on the date of manufactured</p> <p> Follow instructions for use</p> <p> 310kg</p>
---	---

Note (3) : 230 Vac version (also available on request 210 / 220 / 240 Vac Mains Power Supply),
 120 Vac version (also available on request 100 / 110 / 130 Vac Mains Power Supply).

Note (4) : with Mains Power Supply from 100 to 130V, 16A magnetothermal switch,
 with Mains Power Supply from 210 to 240V, 10A magnetothermal switch.

Note (5) : UDI : 8055 186670433 = model: **Agility -SR21**
 UDI : 8055 186670440 = model: **Agility -SR30**

Note (6) : REF : SR21 = model: **Agility -SR21**
 REF : SR30 = model: **Agility -SR30**

The following ID plates are also found on the components:

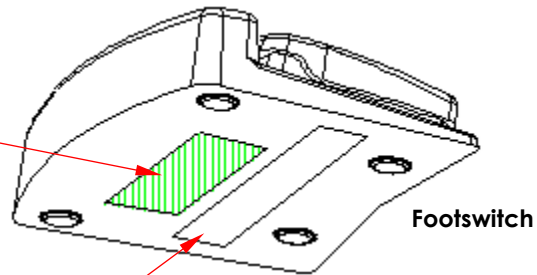

"This device complies with Part 5 of the FCC Rules. Operation is subject to the following two conditions:
 (1) This device may not cause harmful interference, and
 (2) this device must accept any interference received, including interference that may cause undesired operation."

The **wired footswitch** has class **IP X7** protection:

- ("X"): no protection against the introduction of little-dimension solid foreign bodies.
- ("7"): protection against the infiltration of liquids during **temporary immersion (max 30 minutes)**.

The **wireless footswitch** has class **IP 67** protection:

- ("6"): total protection against the introduction of little-dimension solid foreign bodies.
- ("7"): protection against the infiltration of liquids during **temporary immersion (max 30 minutes)**.

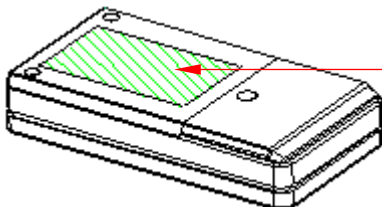

Infrared remote control

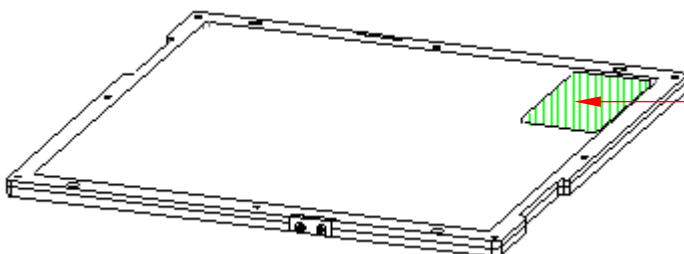
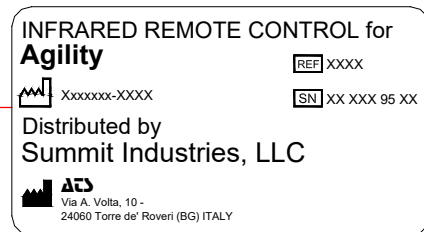

x-ray grid

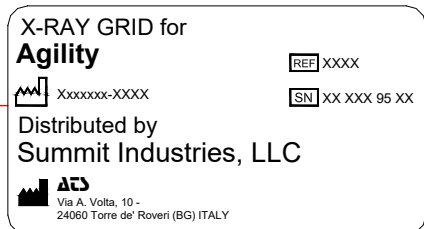

3 LIABILITY STATEMENT



The manufacturer can only be held liable for the safety of its products if serviced and repaired by the manufacturer or by suitably trained and qualified personnel. The manufacturer holds regular training courses for technicians, fitters and maintenance workers at its head offices for this purpose.



The manufacturer cannot be held liable for any malfunction, loss or danger arising from improper use of the EM equipment or from non-observance of the maintenance instructions.



The organisation responsible for the EM equipment is responsible for making sure that it is only and exclusively used by suitably trained and qualified operators.



Never attempt to modify the EM equipment without first obtaining written authorisation to do so from the manufacturer.



The manufacturer provides working diagrams and layout drawings, component lists and descriptions and calibration instructions to assist the technical personnel when repairing parts of the EM equipment.

4 CONFORMITY AND MANUFACTURER'S ADDRESS

This X-ray device is produced by:

 Applicazione Tecnologie Speciali srl Via A. Volta, 10 24060 Torre de' Roveri (BG) - Italy - TEL. +39/035584311 FAX +39/035580220 e-mail: infoats@atsmed.it  http://www.atsmed.it/

The equipment complies with European Directive 93/42 EEC and subsequent amendments, 2007/47 EEC.

The following harmonised standards apply to the EM equipment:

EN 60601-1 :	2006 + A1 : 2013
EN 60601-1-2 :	2014
EN 60601-1-3 :	2008 + A1 : 2013
EN 60601-1-6 :	2010 + A1 : 2013
IEC 60601-2-28 :	2017
EN 60601-2-54 :	2009 + A1 : 2015
EN 62304 :	2006 + A1 : 2015
EN 62366-1 :	2015
EN 62563-1 :	2010
EN ISO 14971:	2012
EN 60825-1:	2014
EN 60601-2-43:	2010 + A1 : 2017
EN ISO 15223-1:	2016
EN 1041:	2008
EN ISO 780:	2015

Note 1: These standards are mentioned both in Technical and User manuals; please refer to this list if the edition of the standards is not specified.

Note 2: The system **does not** contain any patient applied parts.



User Manual

 EN code 95 80 009

MAIN CONTENTS

PART 0 : PREFACE

PART 1 : GENERAL DESCRIPTION

PART 2 : USE

User Manual

Date of issue 01/03/2021

Revised on 21/03/2022

Software release: 2.5.x.x

ATTENTION:

Read all the enclosed documents before using the EM equipment.



This USER MANUAL is only considered complete when preceded by the document called the PREFACE.

Each part of this User Manual is preceded by a list of contents indicating the latest edition of each chapter

Part 1 : GENERAL DESCRIPTION

CONTENTS

	pages	rev.	Date
CONTENTS	1.1-1.2	0	01/03/21
1 DESCRIPTION OF THE ELECTRICAL MEDICAL EQUIPMENT	1.1 - 1.30	0	01/03/21
1.1 Intended use			
1.1.1 Device Class			
1.1.2 Electrical data			
1.2 Composition of the EM equipment			
1.2.1 Stand			
1.2.2 Control Panel			
1.2.2.1 Buttons			
1.2.2.2 Indicators			
1.2.3 Stand controls			
1.2.4 Exposure commands			
1.2.5 Infrared remote control			
1.3 Monitor			
1.3.1 Study List frame			
1.3.2 Working frame			
1.3.3 Spacer			
1.4 Exposure modes			
1.4.1 mAs table			
1.5 Dose information			
1.5.1 Indications			
1.5.2 Reference Air-Kerma			
2 SAFETY	2.1 - 2.22	0	01/03/21
2.1 Introduction			
2.2 Safety procedures			
2.2.1 Mechanical safety			
2.2.2 Electrical safety			
2.2.3 Network safety			
2.2.3.1 Update Windows antivirus			
2.2.4 Emergency procedures			
2.2.4.1 Emergency buttons			
2.2.4.2 Software glitches that can be restored by the operator			
2.2.4.3 System failure			
2.2.5 Equipotential earth connector			
2.2.6 Laser radiation			
2.2.7 Protection against ionizing irradiation			
2.2.7.1 Contra-indications on using the EM equipment			
2.3 Residual risks			
2.4 Scrapping the EM equipment			
2.5 Warnings			
2.5.1 Symbols used			
2.5.2 Status and alarm messages on Control Panel			

- 2.6 Manufacturer's guidelines and declaration
 - 2.6.1 Electromagnetic emissions
 - 2.6.2 Electromagnetic immunity
 - 2.6.3 Recommended separation distances between system and portable and mobile RF communications equipment

3 TECHNICAL DATA

3.1 – 3.17

0

01/03/21

- 3.1 Device class
- 3.2 Technical characteristics
 - 3.2.1 Mechanical / electrical data
 - 3.2.2 Imaging system
 - 3.2.3 Exposure modes
 - 3.2.4 Accuracy of loading factors
- 3.3 Overall dimensions and weights
- 3.4 Focal spot position
- 3.5 Fluoroscopy mA curves
- 3.6 Digital radiography (snapshot) mA curves
- 3.7 X-ray tube IAE RTM70H curves
- 3.8 X-ray monoblock I-40R 15 RF curves

1 DESCRIPTION OF THE ELECTRICAL MEDICAL EQUIPMENT

1.1 INTENDED USE

The equipment is a mobile x-ray device used for radiological guidance and visualization during diagnostic, interventional and surgical procedures.
 In particular, the device is to be applied during orthopaedic, neuro, abdominal, vascular, thoracic, and cardiac procedures.

This device can be used on all patients except pediatric patients within the limits of the device.

Note: *This EM equipment is not suitable for vascular diagnosis.*

The equipment allows for image acquisition in the following modes:

- **Low Dose** Fluoroscopy
- **High Quality** Fluoroscopy
- **Digital radiography**
- Fluoroscopy in **Road Mapping** mode (optional)
- Fluoroscopy in **DSA** mode (optional)

1.1.1 DEVICE CLASS

Type of protection against electrical contacts:	Class I
Degree of protection against electrical contacts:	The system does not contain any patient applied parts.
Degree of protection against water penetration:	Common equipment
Degree of safety in the presence of inflammable gases:	not suitable for use in the presence of inflammable gases
Operating conditions:	Continuous operation

1.1.2 ELECTRICAL DATA

POWER SUPPLY		
Single-phase voltage	230 Vac ± 10% 50Hz, 60 Hz	120 Vac ± 10% 50Hz, 60 Hz
Max consumption	- Fluoroscopy 10 A - Radiography 22 A	- Fluoroscopy 16 A - Radiography 22 A
Line resistance	max 0.4 Ohms	
Connector	NEMA 5 - 20 A	

1.2 COMPOSITION OF THE EM EQUIPMENT

- 1 Stand
- 2 X-Ray footswitch
- 3 Infrared remote control



1.2.1 STAND

- 1 Control Panel
- 2 Touchscreen monitor for image display during X-ray emission and the last image acquired (LIH), for display and processing of the images saved on the hard disk.
- 3 X-ray monoblock
- 4 X-ray collimator
- 5 Flat panel detector
- 6 Base unit, containing power supply group and control unit for the equipment
- 7 Key for powering on / off the device
- 8 NFC reader (optional)
- 9 C-arm orbiting grips
- 10 C-arm orbiting brake
- 11 C-arm rotation brake
- 12 Longitudinal C-arm movement brake
- 13 Longitudinal C-arm movement handle
- 14 "Wig-wag" angle brake
- 15 Guide knob ($\pm 90^\circ$) for rear wheels and stand parking brake control
- 16 Support handles for moving the stand
- 17 C-arm column Up/Down button
- 18 Monitor support arm
- 19 Monitor support brake
- 20 Monitor swivel brake
- 21 Monitor height adjustment brake
- 22 X-ray command button
- 23 Emergency stop buttons (column motor)
- 24 Emergency stop button for the entire EM equipment
- 25 Footswitch cable connector
- 26 Injector connector
- 27 Equipotential earth connector
- 28 X-ray emission warning light / Remote control receiver
- 29 Laser light localizers (optional)
- 30 Dose Area Product (DAP, *optional*)
- 31 Anti-scatter grid
- 32 USB sockets for export of stored images
- 33 Connector for Ethernet network cable (DICOM)
- 34 Video connector for auxiliary monitor (HDMI)
- 35 Support for putting away cables after operation
- 36 Infrared remote control
- 37 General circuit breaker
- 38 EM equipment power supply cable

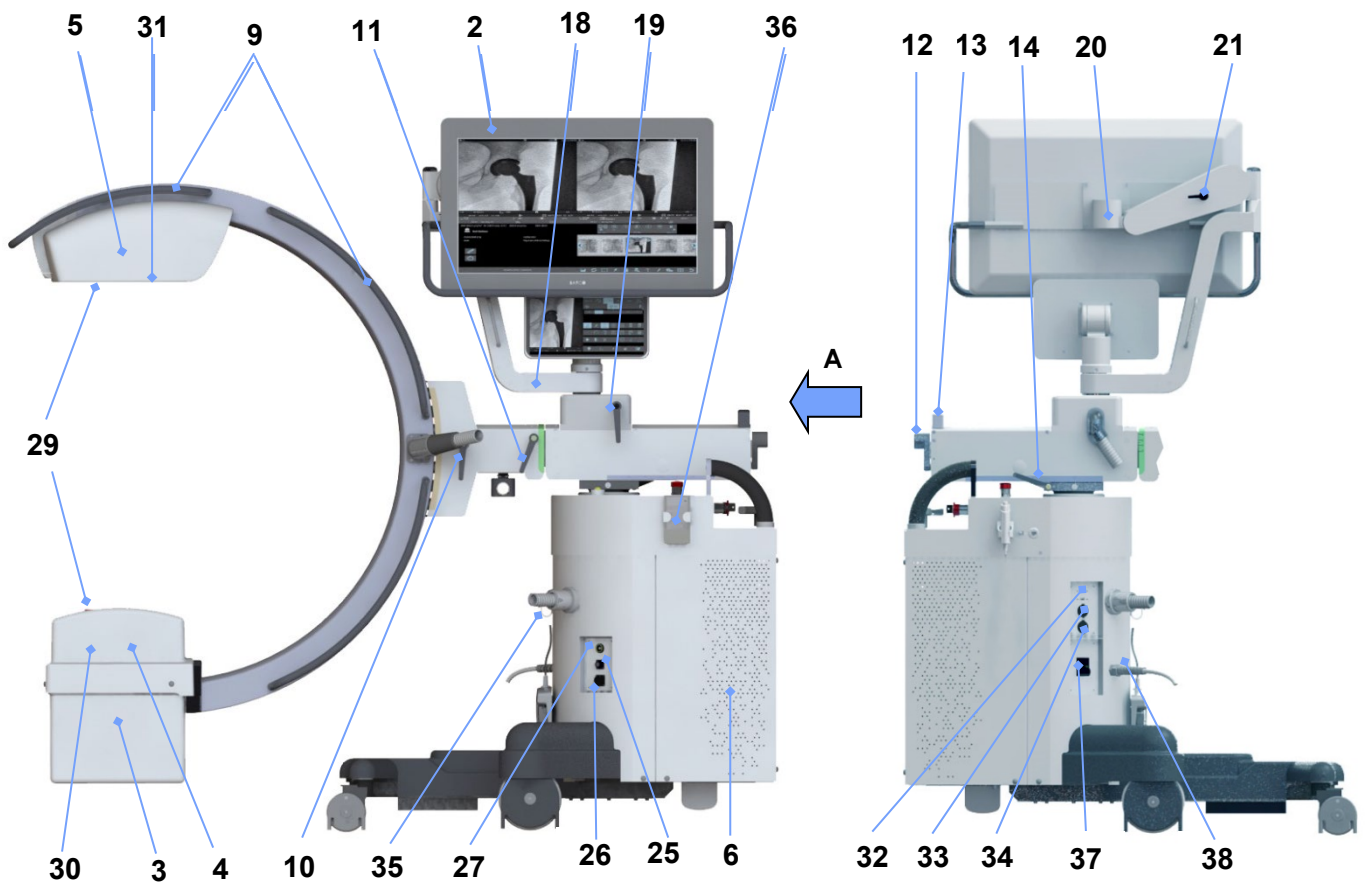
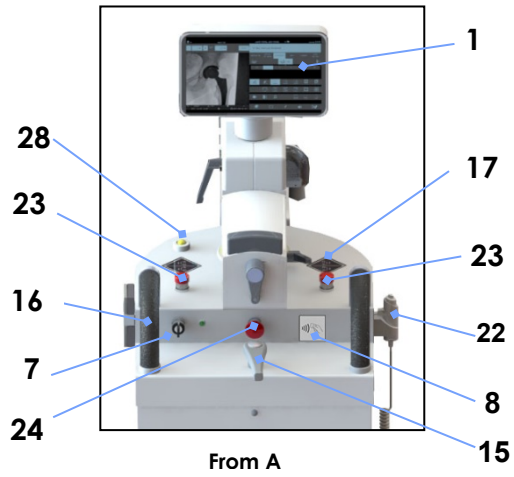

1.2.2 CONTROL PANEL

The control panel on the stand may display the login screen, the different study lists (Patient List, Study WorkList, Query Retrieve List) and all the functions needed for image acquisition.

These include:

- The live image or the last image acquired (LIH).
- Exam selection keys.
- Acquisition mode selection keys: Low Dose fluoroscopy, High Quality fluoroscopy, Digital Radiography, RoadMapping mode fluoroscopy and DSA mode fluoroscopy.
- X-ray generator setup keys for kV and mAs (only available on digital radiography).
- X-ray collimator control keys.
- Acquisition parameter setup keys (process algorithms, pulse rate, etc.).
- Image saving keys.
- Status and alarm information.



See below for a detailed description of the various controls and indications.

LOW DOSE FLUOROSCOPY:

For low dose X-ray exposures



HIGH QUALITY FLUOROSCOPY:

For high quality X-ray exposures



RAD:

For X-ray exposures in digital radiography mode



Note: For RoadMap and DSA acquisition mode (optional), please refer to chapter 4 of this manual.

1.2.2.1 BUTTONS

SETTING OF X-RAY PARAMETERS		Increase / decrease kV. This function is enabled in standby and during X-ray emission when you select the dose in manual fluoroscopy mode.
		Increase / decrease mAs. This function is enabled only in digital radiography mode.
		Fluoroscopy selection with automatic / manual dose control. Simply press the button to switch from one mode to the other.

EXPOSURE MODES		Selection of Low Dose fluoroscopy and the acquisition rate.
		Selection of High-Quality fluoroscopy and the acquisition rate.
		Selection of digital radiography.
		Selection of Road Map mode and the acquisition rate.
		Selection of DSA mode and the acquisition rate.

ANATOMICAL EXAMS		Exam selection. The exams can be set in the relevant menu. The exam list can be scrolled further by pressing the lateral arrows.

FIELD FLAT PANEL DETECTOR	FPD 21 x 21		
			Nominal Field (21 x 21 cm ²)
			1st zoom (16 x 16 cm ²)
			2nd zoom (12 x 12 cm ²)

FIELD FLAT PANEL DETECTOR	FPD 30 x 30		
			Nominal Field (30 x 30 cm ²)
			1st zoom (21 x 21 cm ²)
			2nd zoom (16 x 16 cm ²)

		OFF	ON	
X-RAY COLLIMATOR AND LASER				Laser localizer ON/OFF (1 min power up time)
				Collimator complete opening with a single touch
				This key opens the collimator control menu (shutters and squared iris). The collimator control can be carried out directly on the image with the commands on the left (see paragraph 2.3.10, Part 2 of this manual), or using the keys within this menu. The following commands are available:
				Enable the options for asymmetric adjustment of the shutters
				Show or hide the symbols for adjusting the collimator opening directly on the image
				This key is meant to open the collimator squared iris to the default value that has been set in Exam Setup menu (See Paragraph 4.4, Part 2 of the Technical Manual).
				Open/close shutters





			Clockwise / Counter-clockwise rotation of the shutters
			Open/close squared iris













































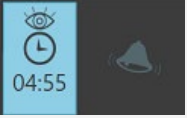

IMAGE ORIENTATION			Use this button to open the image orientation menu with these functions:
			Clockwise / anti-clockwise image rotation in steps of 1°
			Clockwise / anti-clockwise 90° image rotation
			Image rotation reset (0°)
			This key gives the operator the possibility to freely rotate the image by dragging it with his finger.
	OFF	ON	Horizontal image flip
			

IMAGE SAVING AND MANAGEMENT	OFF	ON		
				Save single live fluoroscopy image to hard disk (or LIH image)
				Save all subsequent fluoroscopy images in current study to hard disk.
				Use this button to open the menu that lets you manage saved images, shown on the memory monitor. It contains the following icons:
				Transfer image from the Memory area to the Live area of the monitor.
				Find run of images within the study
				Find images within a run.
				Start / Stop cine-loop of images in a run.
				The Reference Image key lets you keep the view of the selected reference image, it disables the search buttons for images and runs. Press the key again in order to leave the function (see Paragraph 2.3.13, Part 2 of this Manual).
				Pin image: This key adds a marker to the image viewed.

	This key opens the Live Drawing function (see paragraph 3.1.2, Part 2 of this manual).		
	This key enables the stopwatch function. It is visible both on the Control Panel and on the Live Monitor. This function is useful whenever you need to measure the duration of specific procedures (See Paragraph 2.3.11, Part 2 of this Manual).		
	When enabled, this key allows to see on CP and LM, in the center of the image area a sight (two different shapes). It turns to be very useful in particular procedures. (for further information, see Paragraph 2.3.12, Part 2 of this Manual).		
	This key opens the image processing menu for the selected image.		
	This key lets you modify the value of the Noise Reduction factor which is applied to the image.		
	This key allows to restore W and L image values, as they were at the acquisition.		
OFF	ON		
		GREY SCALE inversion.	
		Use these buttons to enable / disable the digital movement-sensitive recursive filter.	
			Select the specific image dynamics control processes for the selected exam (DRC, dynamic range compression).
			Select the spatial digital filters (edge smoothing / sharpening).

	OFF	ON	
EXTRA FUNCTIONS			Enable / Disable acoustic X-ray emission signal in fluoroscopy.
			Enable / Disable X-ray commands.
			Start detector offset calibration (press for about three seconds to start the calibration).
			ROI manual selection for automatic KV/mA regulation in fluoroscopy.

RESET INDICATIONS		<p>Total fluoroscopy timer (minutes and seconds). Keep key pressed for at least 3 seconds to reset the timer.</p>
		<p>5 minutes' fluoroscopy alarm. Reset the alarm by touching the alarm icon.</p>

EXIT STUDY		<p>The key closes the menu and opens the study list</p>
-------------------	---	---

1.2.2.2 INDICATORS

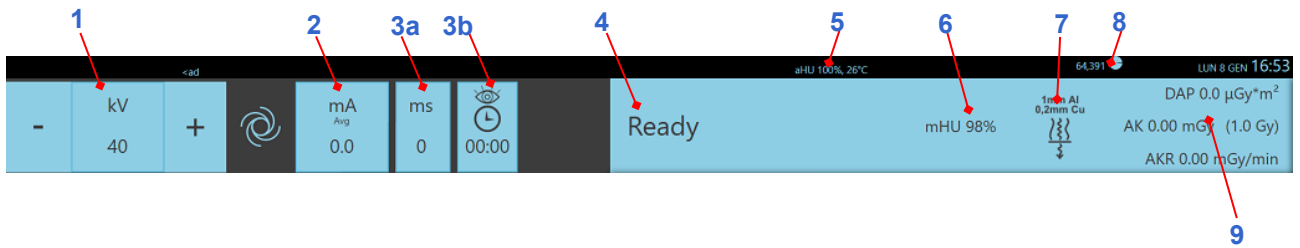

1		Fluoroscopy / radiography kV
2		- radiography mAs - average mA per second in fluoroscopy
3a		X-ray pulse duration (in milliseconds)
3b		Accumulated fluoroscopy time reported in minutes and tenth of minutes (eg: 1.3 min is 1 minute and 18 seconds).
4		Mode / Status and alarm messages
5		% of heat units, available in anode (aHU). (100% = anode is cold) Monoblock temperature (in Celsius or Fahrenheit degrees: see Paragraph 4.2 in Part 2 of the Technical Manual to set the required option).
6		% of heat units, available in Monoblock (mHU). (100% = monoblock is cold)
7		It shows the X-ray beam filter set for the selected exam. It is possible to assign one of the available filters to each exam. (see Paragraph 4.4, Part 2 of the Technical Manual).
8		Indication of number of images that could still be acquired. It is calculated on number of RAD images (those with the highest resolution).
9		DAP: Accumulated X-ray dose x area during study (Dose Area Product) AK: Air-Kerma accumulated during the study AKR: Air-Kerma Rate

1.2.3 STAND CONTROLS

The stand features the following controls:

- the key switch for powering on or off the device
- the controls for up and down movement of the C arm
- the emergency pushbuttons (for stopping the up and down mechanism of the C-arm and for the emergency stop of the entire unit).

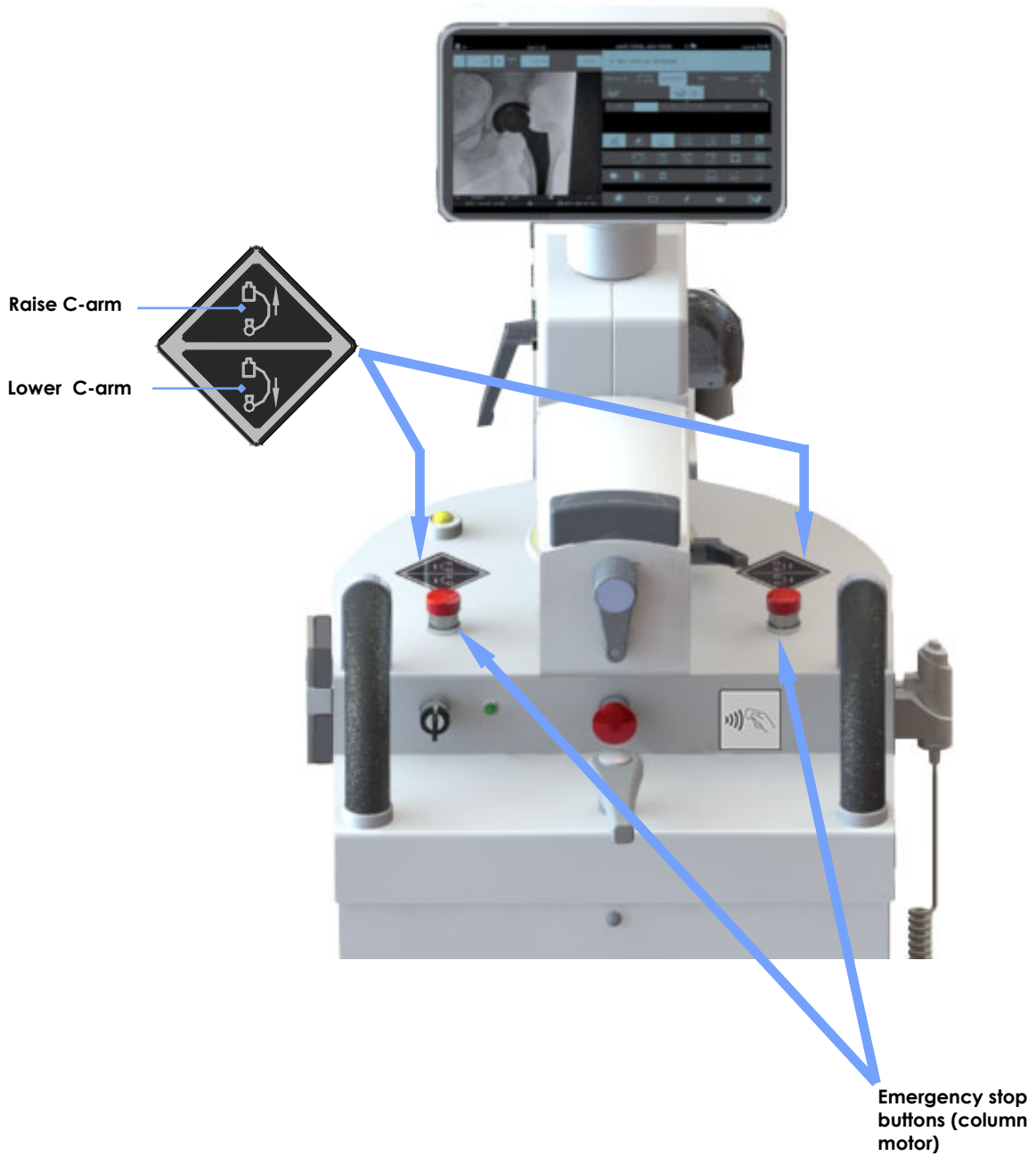

1.2.4 EXPOSURE COMMANDS

The system is equipped with a DOUBLE PEDAL FOOTSWITCH and a BI-FUNCTIONAL HANDSWITCH.

• **DOUBLE PEDAL FOOTSWITCH**

Connect the X-ray command footswitch to the stand as shown in the figure below.

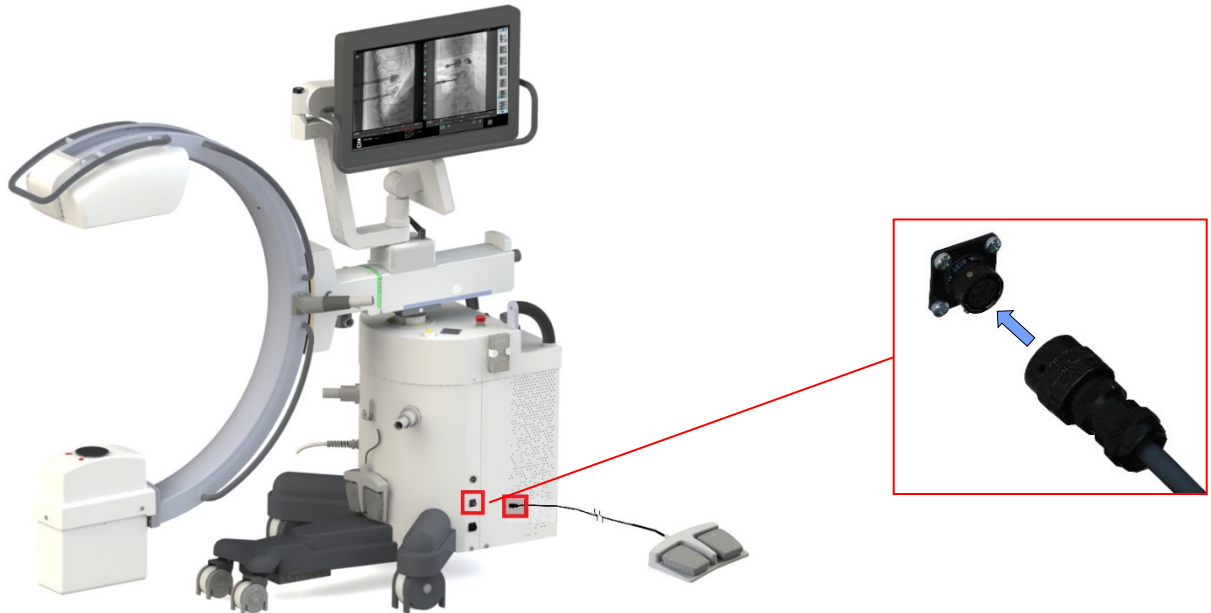

It is possible to assign different acquisition modes to the **two** pedals of the footswitch (for configuration details, please refer to Paragraph 4.4, Part 2 of the Technical Manual).

- As a default, the left pedal is configured to control the **Low Dose Fluoroscopy** mode.
- The pedal on the right can be configured with another preset mode (**High Quality Fluoroscopy, Snapshot, RoadMap or DSA Fluoroscopy**), according to the specific needs. It is possible to decide, for each exam in the exam list, what kind of acquisition mode to associate to the right pedal. The preset mode will then be selected automatically when opening the exam.

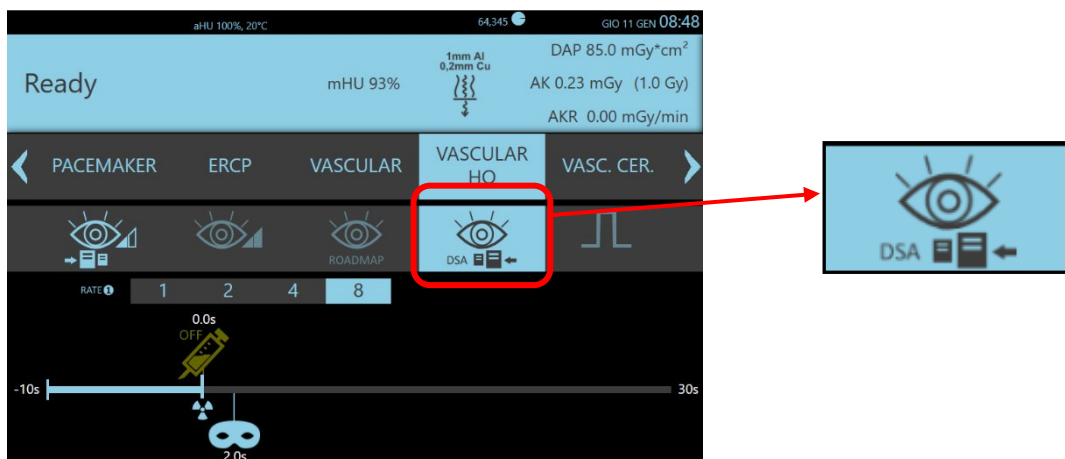

However, it is possible to change these settings directly in the Control Panel but only for the exam currently carried out: simply press one of the other acquisition modes available for this type of exam, it will then become the temporary acquisition mode for the pedal on the right.

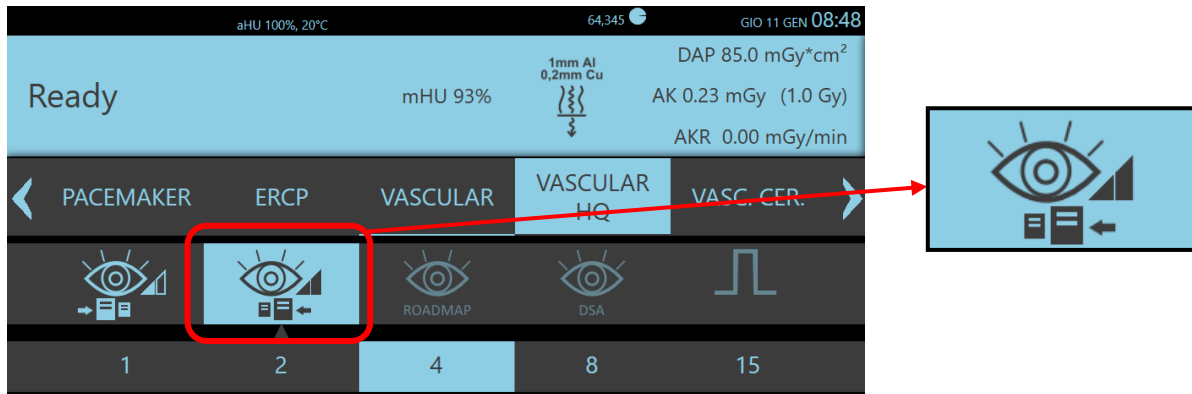

• WIRELESS DOUBLE PEDAL FOOTSWITCH (OPTIONAL)

The operation mode is the same as wired footswitch described above; the X-ray emission command is sent to a receiver placed on the stand left side.

Connect the receiver to the stand as shown in the figure below.
 For details about pairing procedure, see Paragraph 3.2.2.2, Part 2 of the Technical Manual.



Note: to optimize battery duration, wireless footswitch automatically goes in **Sleep mode** (standby) if not used for longer than 15 minutes. When the pedal is pressed again, there could be **one second of latency** between x-ray command and x-ray emission: it depends on the reconnection between footswitch and receiver.

● BI-FUNCTIONAL HANDSWITCH

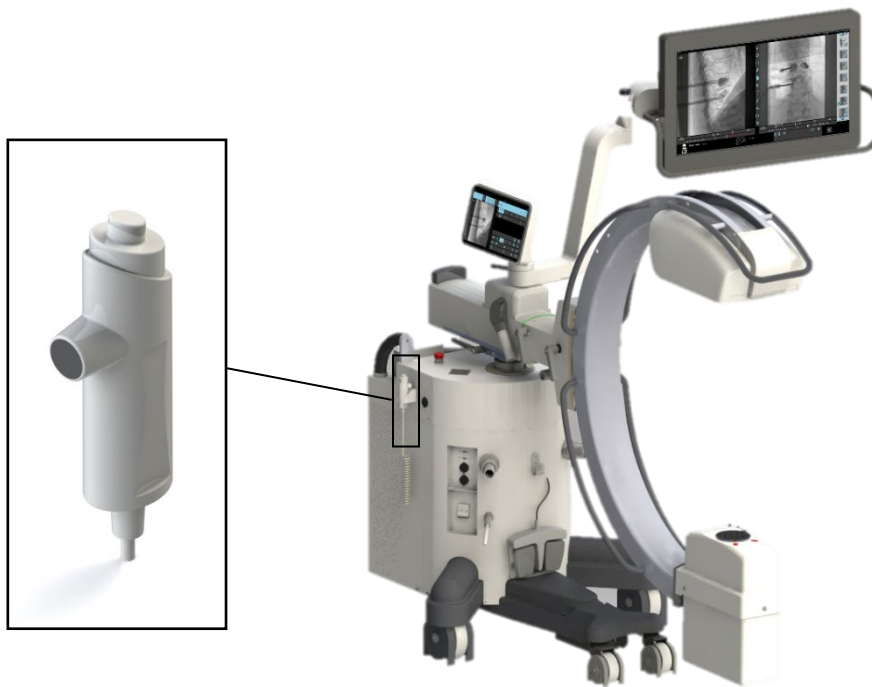

It is possible to assign different acquisition modes to each of the two function buttons of the **bi-functional handswitch**.

Their setting is like the one of the two footswitch pedals: the **frontal function button** (black colored) has the same setting as the left pedal and as a default is configured to control the **Low Dose Fluoroscopy** mode.

The **two-stage function button**, however, will follow the settings made for the pedal on the right. This means in detail, if the **High Quality Fluoroscopy** mode has been set:

- the first stage will give the X-ray emission command,
- the second stage will give the command to save the current image on hard disk (in case that automatic saving of the images is not already set).











Note: for the **RoadMap** and **DSA** functions, the runs are automatically saved.

If the **Radiography** mode has been set:

- the first stage will give the digital radiography preparation command,
- the second stage will give the X-ray emission command.

1.2.5 INFRARED REMOTE CONTROL



A	LED indicating that the infrared remote control is in use
	Image subtraction ON/OFF
	Mask pick-up
	Flag image
	Enable / Disable smart recursive filter (MOTION DETECTION)
	Select Flat Panel detector acquisition field
	Transfer saved image from M.M. to L.M.
	Save single live fluoroscopy image to hard disk
	Save all subsequent fluoroscopy images in current study to hard disk.
	Decrease / Increase fluoroscopy rate
	Find multiframe run of images within the study
	Find images within a run

1.3 MONITOR

Just like the Control Panel, the monitor will display the login screen and the different study lists (*Patient List, Study WorkList, Query Retrieve List*).

During image acquisition it shows the live image as well as the stored images with their respective information.

Furthermore, it is possible to carry out on the monitor the post processing and documentation operations for the images.

When logging in with the Advanced User or Administrator credentials, you can access the setup and adjustment menu of the equipment.







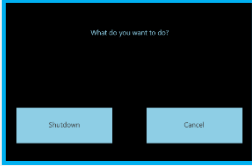

Note: for further details on the login procedure, please refer to paragraph 2.1, Part 2 of this manual.

1.3.1 STUDY LIST FRAME



This frame is subdivided in 3 groups:

Nr.	Information	Icon / Example	Notes / Meaning
1	Study List		List of studies with at least once X-ray exposure. The blue line under the icon indicates the selected list.
	Study Worklist		List of studies still to be performed, either created manually or received from the DICOM WORKLIST.
	Study Query / Retrieve		List of studies received from the DICOM QUERY/ RETRIEVE utility (optional).
	Log-out		Click this button to return to the log-in window.

	Shutdown	 	It is possible: - Turn off the system, - Cancel the shutdown selection.
2	Date study created	01/04/2015	The studies are grouped by date of creation
	Patient first name and surname	JOHN SMITH	
	Date of birth	25/11/1973	
	Gender	M	
	Patient ID	PATID123456	
	Description of the study	THORAX	
	Date and time study created	01/04/2015 13:28	
	Name of operator responsible for study	DR. GREEN	
	Accession Number: unique patient access number	ACCNUM789	
Number of runs / number of images in study	11/193		
3	Open working frame		You will have to select a study first.
	Create new study		
	Select several studies		This lets you select and process more than one study at a time (e.g. for deletion)
	Edit study data		
	Lock a study		A locked study cannot be deleted
	Delete a study		
	Send study to DICOM device		STORE, PRINT and USB
	Study List filter		This lets you search for stored studies by FIRST NAME or SURNAME

1.3.2 WORKING FRAME

The working frame is divided into two main parts:

- The left side shows the live image, or the last image acquired (LIH)
- The right side on the other hand shows a previously acquired image (chosen as reference image) and the list of thumbnail images which are saved in the study up to now.

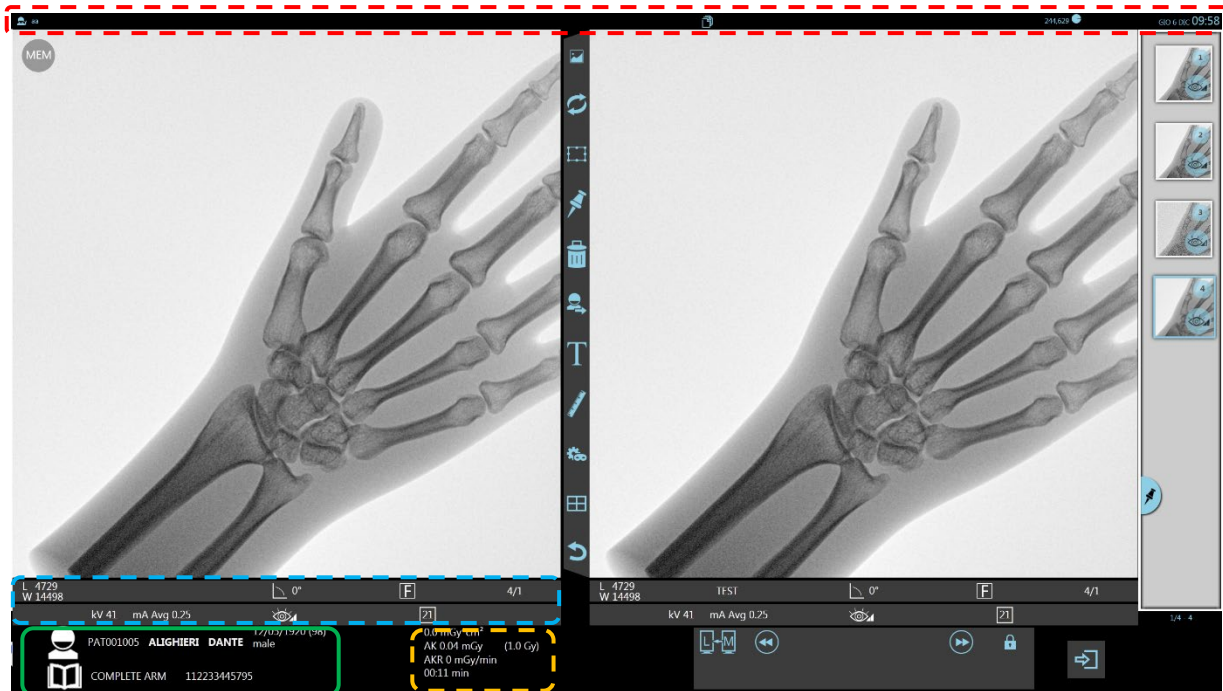





The images are surrounded by information, which is distributed into 5 groups, as indicated in the following table:

Nr.	Information	Example	Notes / Meaning
1	Authenticated operator	User	
	Free space on disk	47079	This is an estimate of the number of images that can still be saved, in terms of the largest image format.
	Current date and time	THU 6 DEC 11:32	
2 Image data	Image Level and Window	L 4864 W 14839	
	Image rotation angle	90°	
	Image orientation	"R"	
	Number of images in run	6/1	The image displayed is the first image of sequence 6 of the study.
	Exposure data	kV 41 mA avg 0.25	In radiography mode, the mAs and ms values are displayed.
	Acquisition mode	HQ FLUOROSCOPY	
	Acquisition field	21	Detector field 21x21 cm ²

3 Dose	DAP	135.2 $\mu\text{Gy}\cdot\text{m}^2$	Accumulated X-ray dose x area product during study
	AK	0.69 mGy	Air-Kerma accumulated during the study
	AKR	0.0mGy/min	Air-Kerma rate in air during the X-ray emission
	TIME	00:41	Total fluoroscopy X-ray emission time
4 Patient data and Study data	Patient name	Dante Alighieri	
	Accession Number	5678	
	Date of birth (age)	01/01/1950 (67)	
	Gender	Male	
	Weight	70	Weight in kg
	Height	170	Height in cm
	Description of the study	HAND	
	Study ID	HAND ID	
	Operator	User	
Exam start date	05/12/2018		
5	Hospital name	HOSPITAL	

On the right side of the monitor, you can find the keys for stored images management:

IMAGE MANAGEMENT		Transfer of a saved image to the place of the Live image
		Find run of images within the study
		Find images within a run. <i>(These keys do not appear unless a run is selected.)</i>
		Start / Stop cine-loop of images in a run. <i>(These keys do not appear unless a run is selected.)</i>
		The Reference Image key lets you keep the view of the selected reference image on the monitor. It disables the search buttons for images and runs. Press the key again in order to leave the function (see Paragraph 2.3.13, Part 2 of this Manual).

In between both images (live and stored) you can find the symbols for the different operations like post processing, documentation, and deletion.

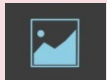

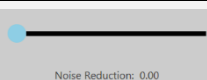
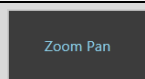













IMAGE PROCESSING			Use this key to open the IMAGE PROCESSING menu that lets you edit the selected image. (See paragraph 3.2, Part 2 of this manual) This menu contains the following functions:
			Automatic / manual WINDOW/LEVEL control selection
			By increasing this factor, it is possible to reduce possible noise on the image. The settings range from 0 (disabled) to 10.
			This key lets you zoom the image and move it inside the visualization frame.
	OFF	ON	GREY SCALE inversion
			
			Choice of spatial filters available for the exam: NONE (no filter), SMOOTH (softer edges), SHARP (sharper edges).
		Choice of DRC processes available for the exam	

IMAGE ORIENTATION			Use this key to open the IMAGE ORIENTATION menu for the selected image. (See paragraph 3.3, Part 2 of this manual). This menu contains the following functions:
			Clockwise / anti-clockwise image rotation in steps of 1°
			Clockwise / anti-clockwise 90° image rotation
			Image rotation reset (0°)
			This key gives the operator the possibility to freely rotate the image by dragging it with his finger.
	OFF	ON	Horizontal image flip
			

ELECTRONIC SHUTTERS		Use this button to apply the electronic shutters (CROP). (See paragraph 3.4, Part 2 of the present manual)

FLAG IMAGE		Use this to flag the selected image or run. (See Paragraph 3.5, Part 2 of this Manual)
------------	---	--

DELETE IMAGE		Use this to delete the selected image or run. (See paragraph 3.6, Part 2 of this manual)
--------------	---	--

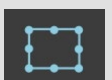







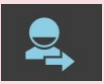

STUDY REPORTING		Use this to open the STUDY REPORTING menu that lets you send the study images to a DICOM device. This menu has the following options:
		STORE DICOM: send images in study to DICOM archive
		Send images in study to USB device
		PRINT DICOM: send images in study to DICOM printer
		PRINT: send the image on the monitor to the local printer
		Send RDSR file (detailing the irradiated dose given to the patient) to the storage device
		This displays the RDSR file detailing the irradiated dose given to the patient
		Export the shown image to USB Drive in DICOM format. (only available in digital radiography mode).

IMAGE OVERLAY		This lets you enable the TEXT function. (See Paragraph 3.8, Part 2 of this Manual)
		This lets you enable the MEASUREMENT and GRAPHIC OBJECTS functions. (See Paragraph 3.9, Part 2 of this Manual)









TOOLS		To activate the DSA functions. (See Chapter 4, Part 2 of this Manual)
-------	---	--

IMAGE OVERVIEW		Use this to open the IMAGE OVERVIEW menu that lets you alter how the study images are viewed. This menu has the following options:
		Show single image
	   	Show multiple images
EXIT		Exits the tool just used
		Exit the exam and return to the study list

1.3.3 SPACER

The minimum source-skin distance is 22 cm.

In some countries, the minimum space required is 30 cm.

For those countries where it is applicable, the appropriate spacer is provided by the manufacturer with the system.

In figure below, the monoblock cover provided with the 8 cm spacer.



1.4 EXPOSURE MODES

LOW DOSE FLUOROSCOPY (LD)	Rate ≤ 15 fps	Rate: 30 fps
Automatic dose control	Yes	
5' Timer alarm	Yes	
10' Max. exposure duration safety	Yes	
Range kV	40 ÷ 120 kV	
Focus	0.3 (SF) - 0.6 (LF)	
X-ray pulse duration	7 ÷ 33 ms	continuous
Peak mA range	0,4 ÷ 10 mA	0,1 ÷ 2.5 mA
Dose value (typical)	12 nGy/frame	12 nGy/frame
kV/mA correlation	See par.1.4.1.4	
Frame/s	1 / 2 / 4 / 8 / 15	30
Reference curves	PULSED CURVE 1 (SF) PULSED CURVE 3 (LF)	CONTINUOUS CURVE 1 (SF) CONTINUOUS CURVE 3 (LF)

HIGH QUALITY FLUOROSCOPY (HQ)	Rate ≤ 15 fps	Rate: 30 fps
Automatic dose control	Yes	
5' Timer alarm	Yes	
10' Max. exposure duration safety	Yes	
Range kV	40 ÷ 120 kV	
Focus	0.3 (SF) - 0.6 (LF)	
X-ray pulse duration	7 ÷ 20 ms	continuous
Peak mA range	1,6 ÷ 40 mA	0,2 ÷ 5 mA
Dose value (typical)	24 or 48(*) nGy/frame	24 nGy/frame
kV/mA correlation	See par.1.4.1.4	
Frame/s	1 / 2 / 4 / 8 / 15	30
Reference curves	PULSED CURVE 2 (SF) PULSED CURVE 3 (LF) PULSED CURVE 4 (LF)	CONTINUOUS CURVE 2 (SF) CONTINUOUS CURVE 3 (LF) CONTINUOUS CURVE 4 (LF)

(*) only for DSA mode

DIGITAL RADIOGRAPHY	Power Supply 230 Vac		Power Supply 120 Vac
	2.8kW	4kW	1.4kW
Range kV	40 ÷ 120 kV		40 ÷ 120 kV
Range mAs	0,5 ÷ 50 mAs		0,5 ÷ 25 mAs
Max X-ray emission time	970 ms		970 ms
Focus	0.3 (SF) - 0.6 (LF)		0.3 (SF) - 0.6 (LF)
mA range	65 ÷ 28 mA	100 ÷ 40 mA	32 ÷ 14 mA
kV/mA correlation	See par.1.4.1.4		
Dose value	- with manual kV and mAs setting: depending on settings - with automatic setting: max 2.5 µGy/frame		
Reference curves	RAD CURVE 1 (SF) RAD CURVE 3 (LF)	RAD CURVE 2 (SF) RAD CURVE 4 (LF)	RAD CURVE 5 (SF) RAD CURVE 6 (LF)

kV/mA correlation

kV	mA PULSED FLUOROSCOPY		mA CONTINUOUS FLUOROSCOPY		mA RADIOGRAPHY		
	LD Fluoroscopy PULSED CURVE 1, 3	HQ Fluoroscopy PULSED CURVE 2, 4	LD Fluoroscopy CONTINUOUS CURVE 1, 3	HQ Fluoroscopy CONTINUOUS CURVE 2, 4	2.8kW RAD CURVE 1, 3	4kW RAD CURVE 2, 4	1.4kW RAD CURVE 5, 6
40	0.4	1,6	0,1	0,2	65,00	100,00	32,5
41	0,48	1,9	0,12	0,24	65,00	97,56	32,5
42	0,56	2,2	0,14	0,28	65,00	95,23	32,5
43	0,64	2,5	0,16	0,32	65,00	93,02	32,5
44	0,72	2,8	0,18	0,36	63,63	90,90	31,81
45	0,8	3,2	0,2	0,4	62,22	88,88	31,11
46	0,88	3,5	0,22	0,44	60,86	86,95	30,43
47	0,96	3,8	0,24	0,48	59,57	85,10	29,78
48	1,04	4,1	0,26	0,52	58,33	83,33	29,16
49	1,12	4,4	0,28	0,56	57,14	81,63	28,57
50	1,2	4,8	0,3	0,6	56,00	80,00	28,0
51	1,6	6,4	0,4	0,8	54,90	78,43	27,45
52	2,0	8,0	0,5	1	53,84	76,92	26,92
53	2,4	9,6	0,6	1,2	52,83	75,47	26,41
54	2,8	11,2	0,7	1,4	51,85	74,07	25,92
55	3,2	12,8	0,8	1,6	50,90	72,72	25,45
56	3,68	14,7	0,92	1,84	50,00	71,42	25,0
57	4,16	16,6	1,04	2,08	49,12	70,17	24,56
58	4,64	18,5	1,16	2,32	48,27	68,96	24,13
59	5,12	20,4	1,28	2,56	47,45	67,79	23,72
60	5,6	22,4	1,4	2,8	46,66	66,66	23,33
61	6,08	24,3	1,52	3,04	45,90	65,57	22,95
62	6,56	26,2	1,64	3,28	45,16	64,51	22,58
63	7,04	28,1	1,76	3,52	44,44	63,49	22,22
64	7,52	30,0	1,88	3,76	43,75	62,50	21,87
65	8,0	32,0	2,0	4	43,07	61,53	21,54
66	8,4	33,6	2,1	4,2	42,42	60,60	21,21
67	8,8	35,2	2,2	4,4	41,79	59,70	20,89
68	9,2	36,8	2,3	4,6	41,17	58,82	20,58
69	9,6	38,4	2,4	4,8	40,57	57,97	20,28
70	10,0	40,0	2,5	5	40,00	57,14	20,0
71	10,0	40,0	2,5	5	39,43	56,33	19,71
72	10,0	40,0	2,5	5	38,88	55,55	19,44
73	10,0	40,0	2,5	5	38,35	54,79	19,17
74	10,0	40,0	2,5	5	37,83	54,05	18,91
75	10,0	40,0	2,5	5	37,33	53,33	18,67
76	9,88	39,5	2,47	4,94	36,84	52,63	18,42
77	9,74	38,9	2,43	4,86	36,36	51,94	18,18
78	9,62	38,4	2,40	4,8	35,89	51,28	17,94
79	9,48	37,9	2,37	4,74	35,44	50,63	17,72
80	9,36	37,4	2,34	4,68	35,00	50,00	17,50
81	9,26	37,0	2,31	4,62	34,56	49,38	17,28
82	9,14	36,5	2,28	4,56	34,14	48,78	17,07
83	9,04	36,1	2,26	4,52	33,73	48,19	16,86
84	8,9	35,6	2,23	4,46	33,33	47,61	16,66
85	8,8	35,2	2,21	4,42	32,94	47,05	16,47
86	8,7	34,8	2,17	4,34	32,55	46,51	16,27
87	8,6	34,4	2,15	4,3	32,18	45,97	16,09
88	8,52	34,0	2,13	4,26	31,81	45,45	15,91
89	8,42	33,6	2,11	4,22	31,46	44,94	15,73
90	8,32	33,2	2,08	4,16	31,11	44,44	15,56
91	8,24	32,9	2,06	4,12	30,76	43,95	15,38
92	8,16	32,6	2,04	4,08	30,43	43,47	15,21
93	8,08	32,3	2,02	4,04	30,10	43,01	15,05
94	7,98	31,9	1,99	3,98	29,78	42,55	14,89
95	7,88	31,5	1,97	3,94	29,47	42,10	14,74
96	7,8	31,2	1,95	3,9	29,16	41,66	14,58
97	7,72	30,8	1,93	3,86	28,86	41,23	14,43
98	7,64	30,5	1,91	3,82	28,57	40,81	14,28
99	7,56	30,2	1,89	3,78	28,28	40,40	14,14
100	7,5	30,0	1,88	3,76	28,00	40,00	14,0
101	7,44	29,7	1,86	3,72	27,72	39,60	13,86
102	7,36	29,4	1,84	3,68	27,45	39,21	13,72
103	7,28	29,1	1,82	3,64	27,18	38,83	13,59
104	7,22	28,8	1,80	3,6	26,92	38,46	13,46
105	7,14	28,5	1,79	3,58	26,66	38,09	13,33
106	7,06	28,2	1,77	3,54	26,41	37,73	13,2
107	7,0	28,0	1,75	3,5	26,16	37,38	13,08
108	6,92	27,6	1,73	3,46	25,92	37,03	12,96
109	6,86	27,4	1,71	3,42	25,68	36,69	12,84
110	6,8	27,2	1,7	3,4	25,45	36,36	12,73
111	6,74	26,9	1,68	3,36	25,22	36,03	12,61
112	6,7	26,8	1,67	3,34	25,00	35,71	12,5
113	6,66	26,6	1,66	3,32	24,78	35,39	12,36
114	6,58	26,3	1,64	3,28	24,56	35,08	12,28
115	6,52	26,0	1,63	3,26	24,35	34,78	12,17
116	6,46	25,8	1,61	3,22	24,14	34,48	12,07
117	6,4	25,6	1,6	3,2	23,93	34,18	11,96
118	6,36	25,4	1,59	3,18	23,73	33,89	11,86
119	6,3	25,2	1,57	3,14	23,53	33,61	11,76
120	6,24	24,9	1,56	3,12	23,33	33,33	11,66

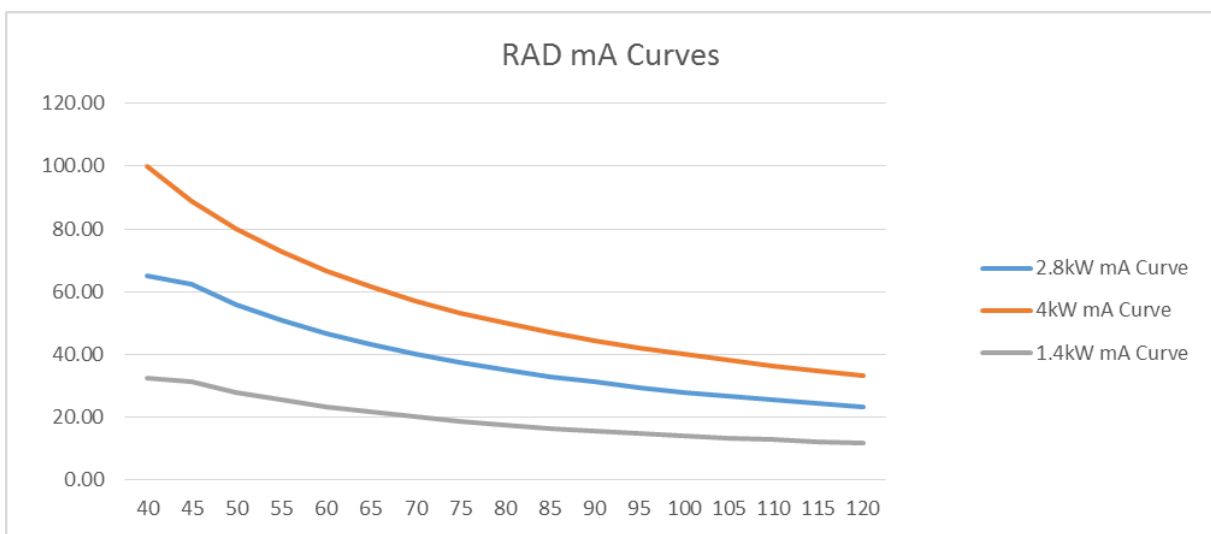
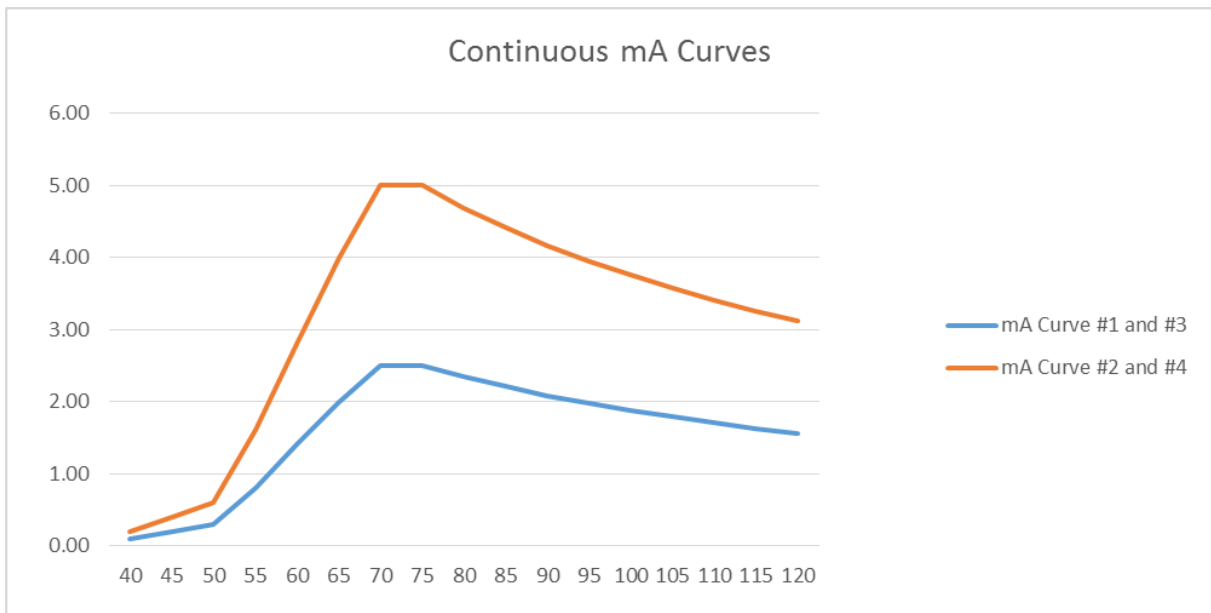
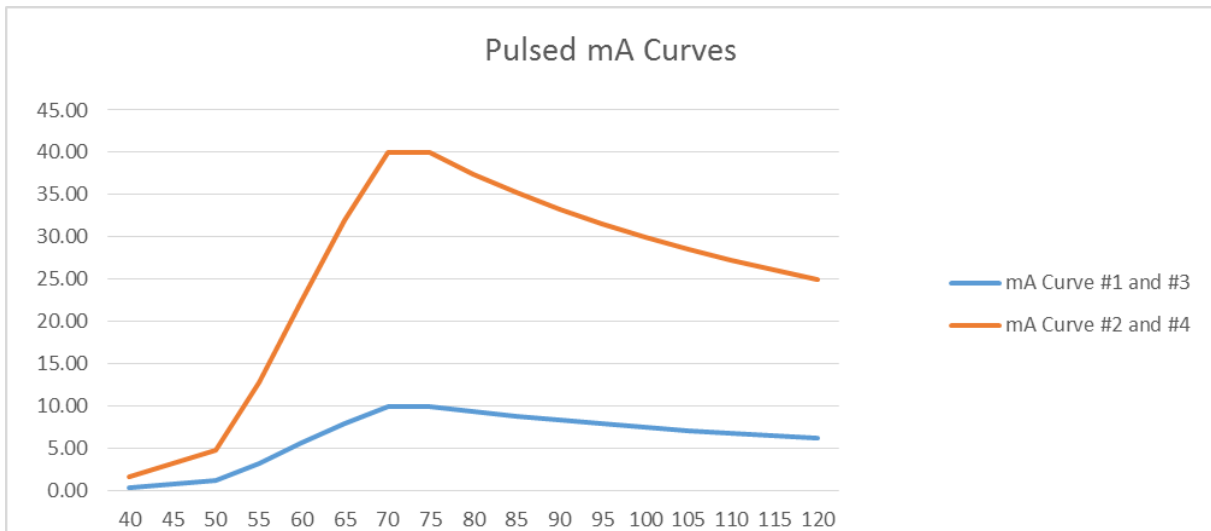

1.4.1 mAs table

R' 10		
mAs values		
	1.00	10.0
	1.25	12.5
	1.60	16.0
	2.00	20.0
	2.50	25.0
	3.20	32.0 (*)
	4.00	40.0 (*)
0.5	5.00	50.0 (*)
0.63	6.30	
0.8	8.00	

(*) Only for Power Supply 230 Vac

1.5 DOSE INFORMATION

1.5.1 INDICATIONS

	Unit of measurement	Instrument	Accuracy
DOSE - AREA PRODUCT	$\mu\text{Gy} \times \text{m}^2$	Dose x Area Product (DAP)	$\pm 25 \%$
REFERENCE AIR-KERMA	mGy	Calculated at the REFERENCE POINT OF ENTRY ON PATIENT, 30 cm from the Flat Panel detector.	$\pm 35 \%$
REFERENCE AIR-KERMA RATE	mGy/min		

1.5.2 REFERENCE AIR-KERMA

The reference Air-Kerma has been measured according to the standard EN 60601-2-54, paragraph 203.5.2.4.5.102, as shown in the figure below.

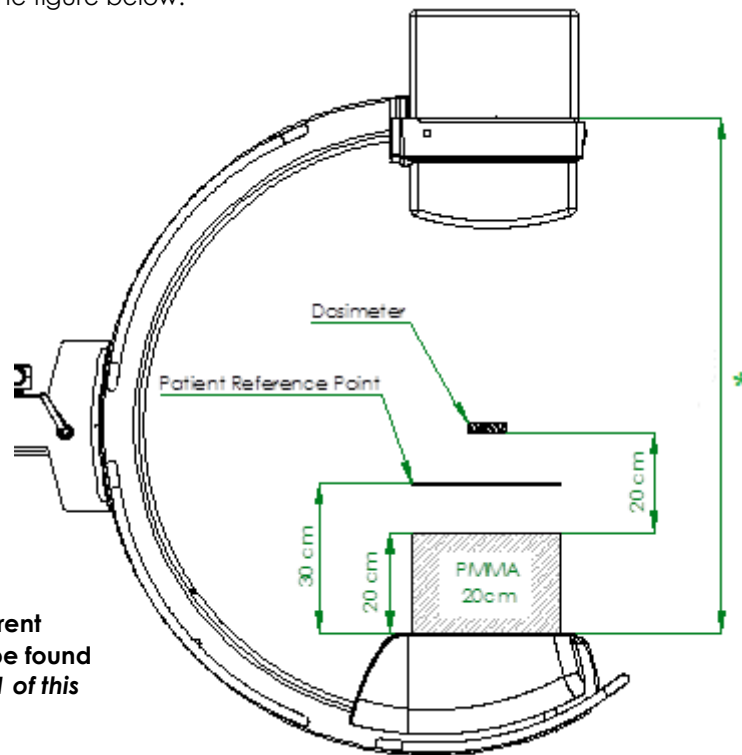

* The SID value of the different available versions can be found in Paragraph 3.2.1, Part 1 of this Manual.

	Low Dose Fluoroscopy (Acquisition rate: 8 fps)					
	kV	mA Avg	Without additional filter	Additional filter 2mm Al	Additional filter 1mm Al+ 0,1mm Cu	Additional filter 1mm Al+ 0,2mm Cu
			Air-Kerma rate ($\mu\text{Gy}/\text{frame}$)	Air-Kerma rate ($\mu\text{Gy}/\text{frame}$)	Air-Kerma rate ($\mu\text{Gy}/\text{frame}$)	Air-Kerma rate ($\mu\text{Gy}/\text{frame}$)
Min Air-Kerma rate	40	0.11	0.24	0.11	0.047	0.0187
	70	2.6	20.8	12.85	8.74	5.78
Max Air-Kerma rate	120	1.64	41.3	30.85	24.42	19.19

	Low Dose Fluoroscopy (Acquisition rate: 30 fps)					
	kV	mA Avg	Without additional filter	Additional filter 2mm Al	Additional filter 1mm Al+ 0,1mm Cu	Additional filter 1mm Al+ 0,2mm Cu
			Air-Kerma rate (μGy/frame)	Air-Kerma rate (μGy/frame)	Air-Kerma rate (μGy/frame)	Air-Kerma rate (μGy/frame)
Min Air-Kerma rate	40	0.1	0,105	0,032	0,013	0.00548
	70	2.5	5.76	3.56	2.42	1.60
Max Air-Kerma rate	120	1.58	11.43	8.53	6.75	5.31

	High Quality Fluoroscopy / DSA (Acquisition rate: 8 fps)					
	kV	mA Avg	Without additional filter	Additional filter 2mm Al	Additional filter 1mm Al+ 0,1mm Cu	Additional filter 1mm Al+ 0,2mm Cu
			Air-Kerma rate (μGy/frame)	Air-Kerma rate (μGy/frame)	Air-Kerma rate (μGy/frame)	Air-Kerma rate (μGy/frame)
Min Air-Kerma rate	40	0.26	0.56	0.26	0.145	0.042
	70	6.4	51.2	31.6	22.48	14.23
Max Air-Kerma rate	120	4	100.7	75.2	59.56	46.8

	High Quality Fluoroscopy (Acquisition rate: 30 fps)					
	kV	mA Avg	Without additional filter	Additional filter 2mm Al	Additional filter 1mm Al+ 0,1mm Cu	Additional filter 1mm Al+ 0,2mm Cu
			Air-Kerma rate (μGy/frame)	Air-Kerma rate (μGy/frame)	Air-Kerma rate (μGy/frame)	Air-Kerma rate (μGy/frame)
Min Air-Kerma rate	40	0.2	0.21	0.064	0,026	0,010
	70	5.0	11.5	7.12	4.84	3.2
Max Air-Kerma rate	120	3.1	22.86	17.06	13.5	10.6

	Digital Radiography					
	kV	mAs	Without additional filter	Additional filter 2mm Al	Additional filter 1mm Al+ 0,1mm Cu	Additional filter 1mm Al+ 0,2mm Cu
			Air-Kerma (mGy)	Air-Kerma (mGy)	Air-Kerma (mGy)	Air-Kerma (mGy)
Min Air-Kerma	40	1	0.24	0.009	0.0078	0.00187
	70	1	0.065	0.042	0.028	0.019
Max Air-Kerma	120	1	0.20	0.15	0.12	0.097

2 SAFETY

2.1 INTRODUCTION

The EM equipment must be used solely in accordance with the safety instructions contained in this manual and in accordance with local regulations. It must never be used for purposes other than those for which it is intended.

Warning:



The manufacturer can only be held liable for the safety of its products if they are serviced and repaired by the manufacturer himself or by suitably trained and qualified personnel. The manufacturer holds regular training courses for technicians, fitters and maintenance workers at its head offices for this purpose.



The manufacturer cannot be held liable for any malfunction, loss or danger arising from improper use of the EM equipment or from non-observance of the maintenance instructions.



The organization responsible for the EM equipment is responsible for making sure that it is only and exclusively used by suitably trained and qualified operators.



The EM equipment must only be used by personnel with proper knowledge of ionising radiation protection and full training in the use of X-ray equipment.



The EM equipment must always be manned when switched on.



The equipment must not be used if there are any electrical, mechanical or radiological failures. Likewise, it must not be used in the event of a faulty alarm or signal.



Prior authorization must be obtained in writing from the manufacturer before making any modifications to this equipment or its safety system.



Never remove any parts or covers, as this could compromise the equipment's electromagnetic compatibility.



If you wish to use the equipment in combination with other devices, components or modules whose compatibility is not certain, you must make sure that there are no risks for patients or operators. Consult the manufacturer of the device in question or an expert.



As with any technical apparatus, the EM equipment must be used in a proper manner and receive regular checks and maintenance as specified in the "Maintenance" section of this manual.



The monoblock may reach a temperature close to 60 °C after prolonged use. Do not touch the monoblock or move it near the patient. When not in use, remove the sterile covers to help the monoblock cool down.



The cover panels must be cleaned following the instructions described in *Chapter 5, Maintenance* of this manual.
Moreover, the device must be installed far enough from objects that could obstruct the air to come out.



Never use corrosive substances (such as sodium hypochlorite, commonly known as bleach) to clean and disinfect the EM equipment.



The quality of the equipment may deteriorate after 10 years of use.
You therefore need to check the mechanical integrity of the equipment, the electrical safety devices and the image quality at the same X-ray dose on a regular basis.



The user must comply to the device basic maintenance and updating recommendations described in this manual, keeping the device up to date.

2.2 SAFETY PROCEDURES

2.2.1 MECHANICAL SAFETY

Warning:



Always apply the parking brakes after positioning the EM equipment.



Only use the special handles to move the equipment.



Avoid knocks or hitting any obstacles.



Never remove the guards unless for the maintenance operations expressly foreseen by and described in this manual.

2.2.2 ELECTRICAL SAFETY

Warning:



Never use the EM equipment in potentially explosive environments, for example in the presence of explosive gases or vapors (such as certain anesthetic gases).



Never use the EM equipment in oxygen-rich environments.



Unplug the EM equipment from the mains before cleaning, disinfecting and sterilizing it.



Cleaning products and disinfectants can form explosive gas mixtures. Therefore, only use products that comply with the relevant safety regulations.



Take care not to spill conducting liquids on the EM equipment as these could infiltrate and so damage the equipment making it unsafe to use.



Protection against electric shock is provided by an earth connection (**class I EM equipment**). Make sure that the electrical plant to which the EM equipment is connected is properly earthed in compliance with current laws and regulations.

Note: *the system does not contain any patient applied parts.*



Always switch the equipment off after use:
Switch the EM equipment off completely by following the monitor stand shut-down procedure; at the end of the procedure, turn the key switch OFF.



Only unplug at the mains after first switching the EM equipment off using the key switch on the monitor unit.

If the power cable becomes damaged, carefully remove it (holding it by the plug) and contact Technical Service for details on how to replace it.

Replace with a new cable obtained from the manufacturer of the EM equipment.

2.2.3 NETWORK SAFETY

The manufacturer provides the EM equipment free of malwares and viruses; this is assured by many precautions during the software installation on the unit. For example:

- the creation of a Master Disk with the latest software revision and operative system,
- the scanning of the Master Disk by an antivirus software (KASPERKY) that runs live from a PENDRIVE,
- the software installation on the unit performed by cloning of Master Disk,
- the continuous updating of the antivirus software that runs from the PENDRIVE.

In case of obsolescence of the Operative System, the manufacturer will provide, on request of the hospital, a new software version, together with instructions for installing it.

The system is provided with the OS firewall enabled and configured according to the software functionalities needs.

In the equipment setup, the **Firewall Info** menu allows Advanced and Administrator users to get notifications about Firewall status and possible alarms or warnings.

To ensure continuous safety and effectiveness of the device software during the life of the unit, it is recommended to:

- connect the access to network (DICOM) on a network that the Responsible Organization considers protected,
- avoid intentional access by malicious or not authorized persons,
- keep the operative system firewall updated (see next paragraph).

A stronger protection can be provided by ensuring that the system is connected to a local network that uses appropriate network security, such as firewalls and antivirus scanning at points of access.



Only a strong network security configuration can ensure that the system is protected against malicious network attacks and that patient data is protected against unauthorized access. It is recommended that the Responsible Organization uses an up-to-date, managed wireless infrastructure that is enterprise-grade and has strong security controls.

If required, it is possible to restore the video processor software using the backup pen drive provided with the equipment: please, keep it up to date with latest changes, if any (settings, etc.).

The system operates in **KIOSK mode**, with Windows Embedded. In this operative mode, it is not possible to start applications from USB pen drive. Furthermore, autorun of the USB pen drive has been disabled. The equipment is provided without antivirus software because its updates should lead to operative difficulties.

Anyway, if you notice strange system behaviour and/or performance occurring repeatedly, including after the system has been restarted, please call the Service.

2.2.3.1 UPDATE WINDOWS ANTIVIRUS

It is important to periodically update the system antivirus in order to grant a stronger protection. The Manufacturer suggests to update the it as a new upgrade is released.

First, you have to access as Windows Administrator (see Paragraph 5.3 **Windows Administrator Login**, in Part 2 of the Technical Manual).

Now, open **Windows Start** menu and search **Virus and Threat Protection**:



- Open **Virus and Threat Protection** and click on **Check for Updates**.

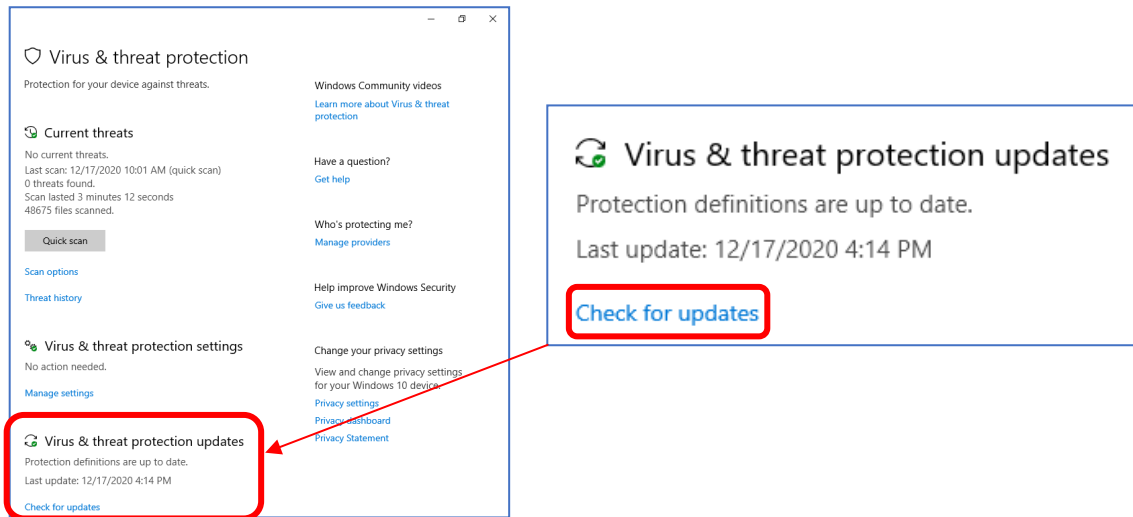

- The system notices about possible updates to be installed.

As the updating procedure has been successfully concluded, from **Windows Start** menu **Turn Off** or **Restart** the equipment.

2.2.4 EMERGENCY PROCEDURES

2.2.4.1 EMERGENCY BUTTONS



If the equipment suddenly malfunctions, use one of the **emergency buttons** (1 on the front part of the monitor station and 2 on the upper part of the stand), as shown by the arrows in the figure below:

- The button (1) switches the entire EM equipment off.
- The two emergency-stop buttons (2) ONLY stop the motorized movement of the column.

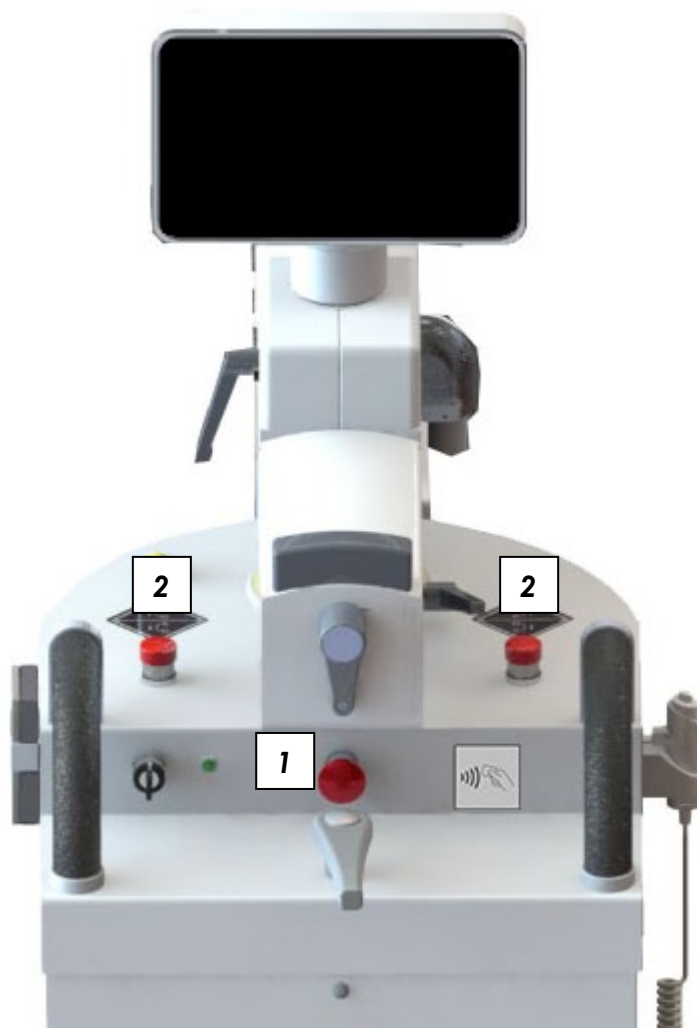

2.2.4.2 SOFTWARE GLITCHES THAT CAN BE RESTORED BY THE OPERATOR

Standard **EN 60601-2-43** requires that it should be possible for the user to restore the system (even partial functioning) in the event of a software malfunction.

The procedure is described in detail in the **Emergency manual** provided with the system.

There are two basic scenarios:

- 1) **The application freezes** (hang up): the device does not respond to any command
- 2) **The application closes** (crash): the working frames close.

⇒ **In the first instance (hang up):**

You need to reboot the equipment.

- Switch off by turning the key to "OFF" (0).
- Wait for about **10 seconds**.
- Switch on back the equipment by turning the key to "ON" (I).

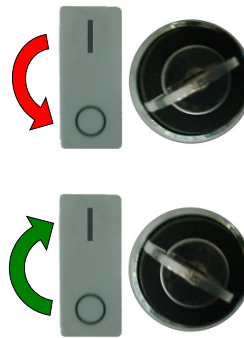

⇒ **In the second instance (crash) the system automatically reboots the application and the LOGIN page appears after initializing.**

Note: in both cases, the equipment will be ready for use in about **1 minute and 30 seconds**.

2.2.4.3 SYSTEM FAILURE



The equipment is a highly complex medical device that in very rare cases can fail, just like any other device, despite of comprehensive tests and maintenance.

This may cause obstruction to the operational procedures.

Please, prepare an emergency plan and keep it ready in case the system cannot be recovered by the operator.

2.2.5 EQUIPOTENTIAL EARTH CONNECTOR

For maximum patient and medical staff safety, the patient bed must be earthed using the equipotential earth connector on the stand.

Use a cable with a Multi-Contact POAG-K4 or POAG-K6 connector to connect this (see detail in figure below).

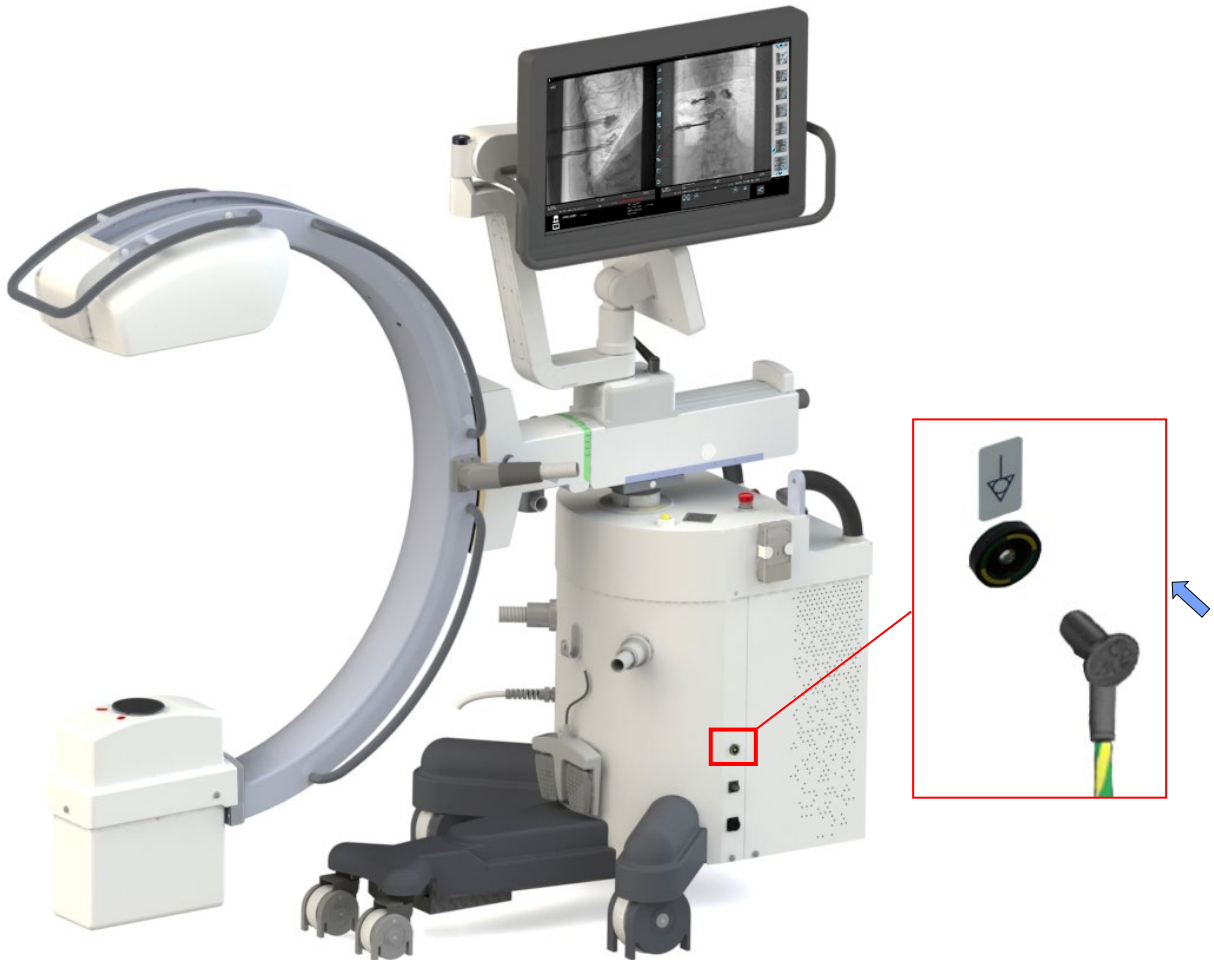

The equipotential earth connector **MUST NOT** be used for connection to the EARTH (GND).

2.2.6 LASER RADIATION

In order to center the X-ray beam, the system uses laser light localizers (optional), class 1M, which are placed on the flat panel detector and on the X-ray monoblock.

LASER LOCALIZER <i>Consisting of 4 laser modules (Optional)</i> (optional)	
Class	1M
Laser diode power	< 5 mW
Optical output power	3.8 mW
Wavelength	635 nm
Laser light warning	



Never look directly at the laser beam through an optical device.

Beware that the laser beam may be reflected by surgical instruments or other accessories used during an operation.

The warning sticker (see image below) is placed on the outside of the detector housing, right next to both lasers.

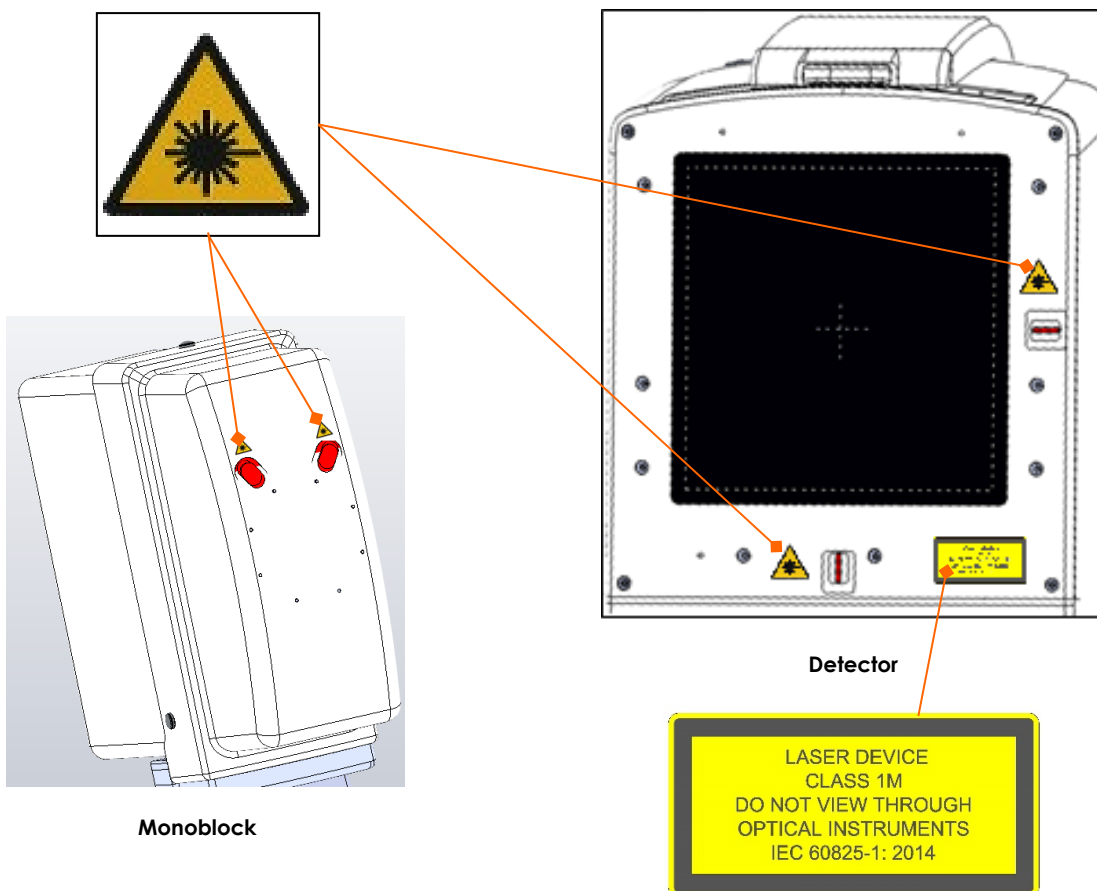

The laser diodes used are class 1M laser diodes (IEC standard 60825-1:2014).

2.2.7 PROTECTION AGAINST IONISING IRRADIATION

The EM equipment emits ionizing irradiation for medical purposes.

X-ray equipment can be harmful if not used in a proper manner.

These instructions must therefore be read in full and fully understood before the equipment can be used.

The use of this device involves two types of exposure to ionizing irradiation:

- ❖ occupational, for operators;
- ❖ diagnostic, for patients being scanned.

Even though the EM equipment provides a high standard of protection against X-rays, no occupational measure can guarantee total protection. The operator must, therefore, take all the necessary safety precautions to avoid the risk of exposure, to himself and others, arising from incorrect or excessive exposure to irradiation (see **Paragraph 2.2.7.1** below for further information about contra-indications on using the EM equipment).

All operators must receive suitable training and adopt all necessary safety measures to avoid the risk of harm.

The equipment is sold on the following condition (clause in the sale contract):

THE MANUFACTURER, ITS AGENTS AND REPRESENTATIVES CANNOT BE HELD LIABLE FOR ANY LOSS OR INJURY THAT MAY BE CAUSED BY IMPROPER USE OF THIS EM EQUIPMENT.



Before carrying out any exposure, make sure that all the necessary irradiation protections have been activated.

During X-ray use, the personnel present in the X-ray room must observe the irradiation protection regulations in force.



Always provide patients with the necessary irradiation protection.



Use suitable personal radio-protective equipment. A radio-protective material equivalent to 0.35 mm of lead gives 99.95% protection against radiation of 50 kV and 94.5% protection against radiation of 100 kV.

Below are examples of such personal radio-protective equipment:



Protective aprons for operators



Protective aprons for patients



Head protection for operators



Thyroid protection for operators



Scrotum protection for male patients



Ovary protection for female patients





Distance is the best protection against irradiation: always keep as far away as possible from the source of the X-rays and from the patient.
Use the manual switch at least 2 m from the X-ray beam to protect yourself further from the risk of dispersed radiation.
Accordingly, the coiled cable of the manual switch is about 4 meters long when fully extended.



Always set the smallest exposure field possible by closing the collimator shutters/iris. In fact, dispersed irradiation depends to a large extent on the volume of the irradiated object.



Avoid moving or remaining within the X-ray trajectory.



Keep the patient as far away from the X-ray source as possible to minimize the absorbed dose.

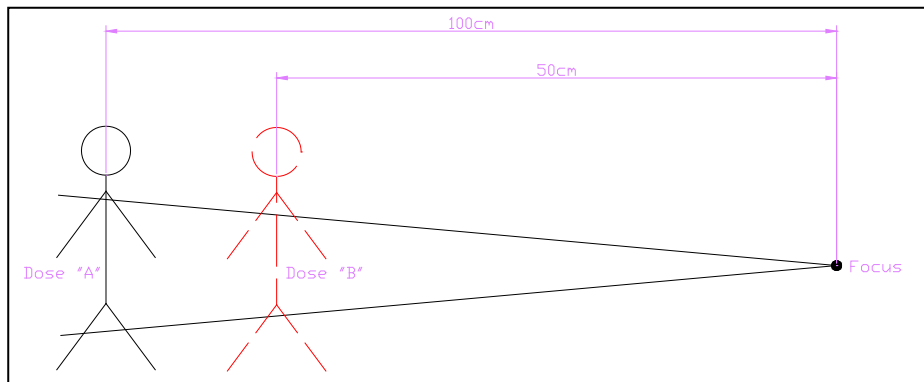

The dose values for the patient shown above (distance from focus = 100 cm and 50 cm) are:

$$dose\ "A" = \left(\frac{50cm}{100cm} \right)^2 \times dose\ "B"$$

For example, if a patient at a distance of 50 cm from the focus receives a dose of 10uGy (dose "B"), when that distance becomes 100 cm the received dose is:

$$dose\ "A" = \left(\frac{50cm}{100cm} \right)^2 \times 10Gy = 2,5uGy$$

Twice the distance results in a four-fold reduction in the received dose.



During every exposure, always make sure that the edge of the iris collimator is visible on the image: if it is not possible to collimate this correctly, request help from the Technical Service as there is the risk that the collimator is not working and remains open at an excessive value.



Make sure that there are no materials within the X-ray beam that could diminish the intensity of the X-rays and so lead to sub-standard images. For example, the patient bed must conform with standard EN60601-2-54 table 203.104 (equivalent aluminum filtration less than 2.3mm).



Patient and operator radiation must be kept as low as reasonably possible without compromising the benefits of the radiological procedure. Where possible, use low dose settings and/or a low frame rate.



Deterministic effects can occur after prolonged exposure, when the X-ray dose received by a given organ or tissue exceeds a specific value (threshold dose).
The SKIN and the LENS are the tissues most affected during radio-diagnostics. The recommended threshold dose is **between 1Gy and 3Gy.**

2.2.7.1 CONTRA-INDICATIONS ON USING THE EM EQUIPMENT

The equipment should not be used if any of the following contra-indications exist (or are thought to exist):

- Acute skin burns, (patient).
- Acute hair loss, (patient).
- Chronic radiation injury (staff).

Note:

- *Special consideration must be given to the protection of the embryo or fetus during radiological examination or treatment of women known to be pregnant.*
- *Sensitive body organs (e.g., lens of eye, gonads) must be shielded whenever they are likely to be exposed to the working beam*

2.3 RESIDUAL RISKS

The EM equipment has been designed and built in full respect of the safety regulations. Nevertheless, there are still some risks involved in the use of this equipment if it is used incorrectly or the prescribed safety measures are faulty.

With regard to risks due to improper use of the EM equipment, see the instructions and recommendations above.

Note also that:

- Patients or operators may be harmed by uncontrolled movement of the stand due to excessively fast movement or steep surfaces.



- Never allow the system to pick up too much speed during movement.
- Never move the system on stairs or inclined surfaces with a gradient of more than 10°.
- When moving the system avoid all obstacles on the ground (e.g. cables and steps).

- The system has been tested for stability during movement on inclined surfaces (up to 10° and all other positions on slopes of up to 5°).



- Never use the stand on surfaces with an incline of more than 5° (or 10° during transit).
- Never try to move the equipment when its parking brake is engaged.

- During transport, in case of uncontrolled movement of the C-arm, the mechanical structure may hit the patient or operators.



- Keep the movement of the C-arm under control at all times.

- The monoblock may overheat after continuous and prolonged use of the EM equipment.



- Never cover the surfaces of the monoblock with material that prevents heat dispersion (sterile sheets excepted).

- Inflammable gases may be ignited by electric arcs due to the operation of electrical components.
 - Never use the equipment in the presence of anesthetics or other inflammable products.
- Check that there is a fire extinguisher in the room where the EM equipment is to be used and that this is efficient.

With regard to residual risks due to faults in the prescribed safety measures, note that:

- Protection against electric shocks is provided by means of an efficient earth system for all metal parts covering the equipment.



- The full earth circuit (for both internal and external parts and the mains supply) should therefore be checked for efficiency on a regular basis (see the "**Routine Maintenance**" schedule described in the Technical Manual).

- If the LCD monitor screen is hit hard enough, it could break and scatter liquid crystal: this is toxic.
- Avoid therefore hitting the monitor with any object.



- The screen is made of crystal and protected by a plastic layer which prevents, in case of hits, the scattering of fragments and the leakage of the jellylike liquid. If the screen is severely damaged, **DO NOT TOUCH THE SCREEN WITH BARE HANDS**; in case of accidental contact with the jellylike liquid which might have leaked, **DO NOT TOUCH EYES OR MOUTH** and wash the exposed body part immediately and thoroughly. If any reactions show, please consult a doctor, informing about the fact that it is related to liquid crystal leaked out of an LCD panel.



The column that raises the monoblock C-arm is motorized.
If the motor responsible for moving the column is accidentally powered up, the operator should immediately push one of the two emergency buttons.



If smoke is seen or unusual noises are heard: switch the equipment off immediately and unplug from the mains.



To control the residual risk of X-ray emission in the event of a system fault or incorrect adjustment, we recommend checking the dose level every day, immediately after switching the equipment on and before using it on patients (details of this test are given in *Paragraph 1.8, Part 2 of this Manual*).



Never remove any parts or covers, as this could compromise the electromagnetic compatibility of the system.



Portable and mobile radio communication devices may affect the efficiency of the device.

2.4 SCRAPPING THE EM EQUIPMENT

Once the EM equipment reaches the end of its useful life, dispose of all its components in accordance with the European Waste Electrical and Electronic Equipment Directive 2012/19/EC (WEEE).

Some parts of the EM equipment are built using hazardous materials, such as lead.

All flat batteries must be disposed of in accordance with European Directive 2006/66/EC and subsequent amendments (concerning batteries and accumulators and battery/accumulator waste).



See the Technical Manual, *Chapter 4, Part 5 for full details*.

2.5 WARNINGS

2.5.1 SYMBOLS USED

Symbols are used on the equipment and serial n° plate, as follows:



Caution: read the accompanying documents before use.

Note: This symbol, on the stand control panel, draws your attention to the absolute need to adhere to the instructions in this manual when using the equipment.



Laser light localiser present



Live parts



Potentially harmful physiological effects



Risk of crushed hands



X-ray focal point



Date of manufacture



Serial number



Manufacturer



Equipment to be disposed of in accordance with European Directive 2012/19/EC requirements ("WEEE" - Handling of Waste Electrical and Electronic Equipment)



Weight of the equipment in Kg.



Equipotential pole



ON (full system)



OFF (full system)



Movement prohibited (with C-arm raised)



Movement possible (transport position)

Note: The stand has been tested for stability during movement on inclined surfaces (up to 10° and all other positions on slopes of up to 5°.

- Never use the stand on surfaces with an incline of more than 5° (or 10° during transit).

- Never try to move the stand when its parking brake is engaged.



Raise C-arm
Lower C-arm













Wheels in straight position



Wheels positioned for side-ways movement



Reference index (c-arm graded plaque)

-  Reference index
-  Brake ON
-  Brake OFF
-  X-ray emission indicator
-  Low Dose fluoroscopy
-  High-Quality Fluoroscopy
-  X-ray emission command
-  Ethernet socket
-  USB socket
-  NFC Reader (optional)

2.5.2 STATUS AND ALARM MESSAGES ON CONTROL PANEL

The status of the system and any active alarms are displayed on the Control Panel, in the relevant area, as shown in the figure below:

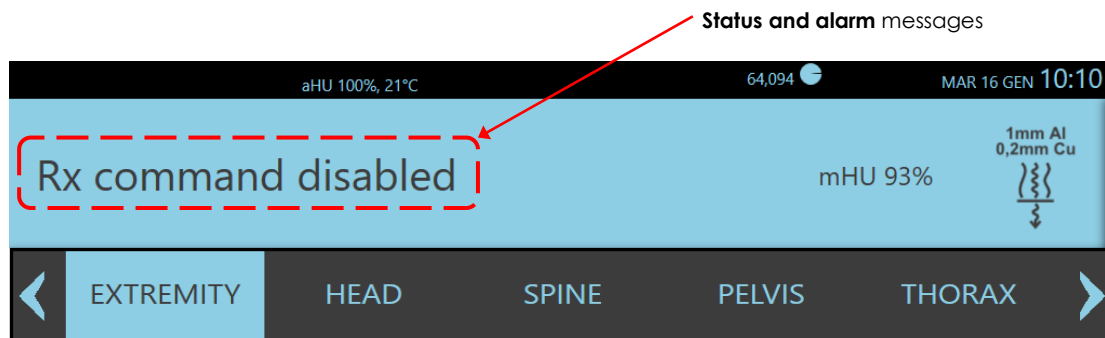

The most recent alarm generated by the system is displayed. Touch the alarm indication to open the frame with a list of all the possibly active alarms:

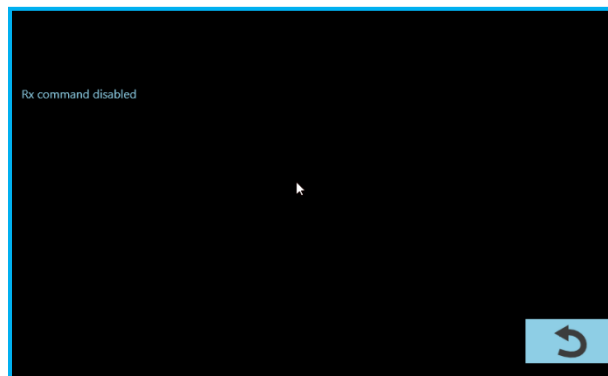

Note: Alarms flagged with an asterisk (*) can be reset by the operator using the reset command, aside the exit key:

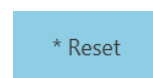

The table below shows the list of messages foreseen by the equipment:

MESSAGE	MEANING	NOTES
READY	The equipment is ready to acquire images. You can now give the X-ray emission command.	
FLUOROSCOPY	X-ray emission in low dose fluoroscopy.	
HQ FLUOROSCOPY	X-ray emission in fluoroscopy mode for high quality images.	
FLUOROSCOPY DSA	X-ray emission in DSA fluoroscopy mode.	
RAD PREPARATION	Preparing for radiography.	
READY FOR RAD	RAD preparation completed.	
RAD	X-ray emission in radiography mode.	
PRE PEAK OPACIFICATION	The equipment is ready to run MAX OP function	
PEAK OPACIFICATION	MAX OP taking is running	
ROADMAPPING	ROAD MAP taking is running	
INSERT RX GRID	Insert the X-ray grid to suit the exam.	X-ray commands are inhibited.
REMOVE RX GRID	Remove the X-ray grid to suit the exam.	
RX SWITCH DISABLED	The X-ray emission commands ((footswitch and button) are disabled.	Press the relevant button on the Control Panel to enable them.
MAX FLUOROSCOPY TIME, RELEASE COMMAND RX	Fluoroscopy exposure has been interrupted on reaching the max accumulated fluoroscopy time-out (10').	Release the X-ray command and reset the alarm.
5 MINUTES FLUORO	Fluoroscopy exposure has been interrupted on reaching the 5-minute fluoroscopy time-out without the warning being reset after 4 minutes and 30 seconds.	Release the X-ray command and reset the alarm.
MAX RADIOGRAPHY TIME	Radiography exposure has been interrupted on reaching the max admissible exposure time-out (970 milliseconds).	Check the quality of the image and repeat exposure if necessary.
MANUAL X-RAY STOP	The radiography command button has been released before exposure has ended.	Check the quality of the image and repeat exposure if necessary.
WAITING FOR FOCUS CHANGE	Wait for the equipment to change the focus.	
CI NOT CONNECTED	System fault.	Close application and restart. Call Technical Service if the alarm persists.
CI INITIALIZATION FAILED	System fault.	Close application and restart. Call Technical Service if the alarm persists.
WAITING FOR CONNECTION	System fault.	Close application and restart. Call Technical Service if the alarm persists.
NO X-RAY ENABLE FROM DETECTOR	Detector communication error.	Repeat exposure. Call Technical Service if the alarm persists.
ERROR SETTING X-RAY COLLIMATOR FILTERS	The X-ray collimator has been incorrectly set.	Select a different exam. Reboot the unit if the problem persists. Call Technical Service if the alarm persists after reboot.

MESSAGE	MEANING	NOTES
RX COLLIMATOR FAULT	The collimator fails to position itself correctly.	Check the position of the collimator. Reboot the unit if the problem persists. Call Technical Service if the alarm persists after reboot.
RX COLLIMATOR OFFLINE	The X-ray collimator is not connected or is faulty.	Call Technical Service.
CTBK OFFLINE	System fault.	Turn off and reboot the equipment. Call Technical Service if the alarm persists.
RECONNECTING CTBK...	The equipment modules are in the process of connecting.	Wait until completed.
UNABLE TO INITIALIZE CTBK FW: VERIFY THE ALARM MESSAGES LIST SHOWN ON THE CONTROL PANEL	System fault. Press the alarm message shown on the control panel: a window appears listing the current alarms. (See page 2.11)	Follow the procedure indicated in this table to resolve the problem shown in the current alarm list. Call Technical Service if the alarm persists.
CTBK INITIALIZATION FAILED	System fault. Impossible to initialize CTBK. Verify the alarm messages list shown on the control panel.	Follow the procedure indicated in this table to resolve the problem shown in the current alarm list. Call Technical Service if the alarm persists.
CTBK HW FAULT	CTBK board fault.	Call Technical Service.
NEW EEPROM CTBK	A new EEPROM has been found by CTBK firmware.	Reboot the equipment. Call Technical Service if the alarm persists.
CTBK POWER SUPPLY +24V FAULT	Problem with the main controller power circuits in the equipment.	Turn off and reboot the equipment. Call Technical Service if the alarm persists.
COM-RX SIGNAL ACTIVE	The signal requesting COMMON acquisition (fluoroscopy and radiography) is already present on switching the equipment on.	Call Technical Service.
FLUOROSCOPY PEDAL CLOSED	Low Dose fluoroscopy pedal is already activated at the equipment starting.	Check whether the left pedal is pressed/blocked and release if necessary. If not, call Technical Service.
FLUOROSCOPY PEDAL HQ CLOSED	High Quality fluoroscopy pedal is already activated at the equipment starting.	Check whether the right pedal is pressed/blocked and release if necessary. If not, call Technical Service.
RAD PREP BUTTON CLOSED	Radiography preparation button is already activated at the equipment starting.	Check whether the X-ray button is pressed/blocked and release if necessary. If not, call Technical Service.
RAD BUTTON CLOSED	Radiography button is already activated at the equipment starting.	Check whether the X-ray button is pressed/blocked and release if necessary. If not, call Technical Service.

MESSAGE	MEANING	NOTES
FLUOROSCOPY BUTTON CLOSED	Low Dose fluoroscopy button is already activated at the equipment starting.	Check whether the X-ray button is pressed/blocked and release if necessary. If not, call Technical Service.
RX TUBE THERMAL SAFETY	The over-temperature thermal safety device in the X-ray monoblock has tripped. Radiography exposure is inhibited when the available heat units fall below the level required for the set exposure.	Wait for the X-ray monoblock to cool down.
RX TUBE TOO HOT	Tube Heat Unit available are not enough to satisfy exposure parameters set.	Wait for the X-ray monoblock to cool down.
LOW POWER	Monoblock or Anode Heat Unit are lower than 10%. Fluoroscopy acquisition mode is still available but the equipment automatically decreases acquiring parameters in order to reduce monoblock heating.	If possible, wait for the X-ray monoblock to cool down.
ANODE STARTER FAULT	Problem in the rotating anode circuit.	Call Technical Service.
RX GENERATOR POWER SUPPLY FAULT	Problem in the X-ray generator circuits.	Call Technical Service.
LOW DOSE AT MAX kV	Insufficient dose level detected at max kV setting.	Check that the collimator is not completely closed. Check that the actual kV level correctly matches the size of the patient being scanned. Change the exam type if necessary.
RX GENERATOR NOT CONNECTED	X-ray generator communication error.	Turn off and reboot the equipment. Call Technical Service if the alarm persists.
FILAMENT FAULT	Problem with the circuit that switches on the X-ray tube filament.	Reset the alarm. Reboot the unit if the alarm persists. Call Technical Service if the alarm persists.
mA TOO LOW	The mA level is 1/3 lower than that foreseen.	Repeat exposure. Call Technical Service if the alarm persists.
mA TOO HIGH	The mA level is 1.5 higher than that foreseen.	Repeat exposure. Call Technical Service if the alarm persists.
kV UNBALANCED	The X-ray generator has detected incorrect voltage at the X-ray tube during exposure.	Reset the alarm. Check the connections between the CP1 connector of the S83 board mounted on the Monoblock and the CM2 connector of the S219 board of the inverter. Request help from the Technical Service if this alarm persists at the next exposure.

MESSAGE	MEANING	NOTES
MAX kV	The X-ray generator has detected too much voltage at the X-ray tube during exposure.	Reset the alarm. Check the connections between the CP1 connector of the S83 board mounted on the Monoblock and the CM2 connector of the S219 board of the inverter. Request help from the Technical Service if this alarm persists at the next exposure.
MIN kV	The X-ray generator has detected too little voltage at the X-ray tube during exposure.	Reset the alarm. Check the connections between the CP1 connector of the S83 board mounted on the Monoblock and the CM2 connector of the S219 board of the inverter. Request help from the Technical Service if this alarm persists at the next exposure.
MAX mA	The X-ray generator has detected too much current at the X-ray tube during exposure.	Reset the alarm. Call Technical Service if this alarm persists at the next exposure.
NO RX	The voltage at the X-ray tube fails to reach at least 75% the expected value during exposure.	Repeat exposure. Call Technical Service if the alarm persists.
DAP FAULT	Dose Area Product faulty.	Reboot the unit to reset the alarm. Call Technical Service if the alarm persists.
POSSIBLE DETERMINISTIC EFFECTS	The Kerma value accumulated during the study has exceeded the threshold (possibly set by the user) beyond which DETERMINISTIC EFFECTS could be detected.	Take care when continuing the procedure.
NO X-RAY DOSE SIGNAL	The X-ray dose signal from the acquisition system has not been detected.	Repeat exposure. Call Technical Service if the alarm persists.
X-RAY GENERATOR NOT CALIBRATED	X-ray generator not calibrated.	Call Technical Service to calibrate this.
MAX PREPARATION TIME	The radiography preparation command has been pressed for too long.	Release the PREP command.
HARDWARE ERROR DETECTOR	Detector fault.	Call Technical Service.
INJECTOR FAULT	Injector cannot activate	Check that the injector is ready and connected to the stand.
X-RAY ACTIVATION NOT FOUND	Lack of synchronism with the detector during exposure. Rx activation button on the Control Panel is enabled.	Repeat exposure. Reboot the equipment if the alarm persists. Call Technical Service if the alarm persists.
FAULTY BEAM SIGNAL	The inverter signals x-rays presence even if they have not been commanded.	Call Technical Service.
X-RAY WATCHDOG ACTIVED	The safety circuit of the x-ray commands has been activated: the x-ray emission is blocked.	Switch off and reboot the equipment. Call Technical Service if the alarm persists.

2.6 MANUFACTURER'S GUIDELINES AND DECLARATION



Never remove any parts or covers, as this could compromise the electromagnetic compatibility of the system.



Portable and mobile radio communication devices may affect the efficiency of the device.

2.6.1 ELECTROMAGNETIC EMISSIONS

Table 1

Manufacturer's guidelines and declaration - electromagnetic emissions		
<p>In accordance with EN standard EN 60601-1-2 (4th edition), the system is intended for use in the electro-magnetic environment specified below. The client or user of the system must ensure that it is used in such an environment.</p>		
Emissions test	Compliance	Electromagnetic environment - guidelines
RF emissions CISPR 11	Group 1	The system uses RF energy only for its internal functioning. Therefore, its RF emissions are very low and are not likely to cause any interference in nearby electronic equipment.
	Class A	The system is suitable for use in all establishments, excluding domestic establishments or those directly connected to the public low-voltage power supply network (mains) that supplies
Harmonic emissions EN 61000-3-2	Not applicable	<p>Note: <i>In case the equipment is used in domestic environments (for which the CISPR 11 indicates CLASS B) it could be that the equipment does not provide adequate protection against radiofrequency interferences. The user will have to adopt attenuating measures such as repositioning or different orientation of the equipment in the environment.</i></p>
Voltage fluctuation / flicker emissions EN 61000-3-3	Not applicable	

2.6.2 ELECTROMAGNETIC IMMUNITY

Table 2

Manufacturer's guidelines and declaration - electromagnetic emissions			
<p>In accordance with EN standard EN 60601-1-2 (4th edition), the system is intended for use in the electro-magnetic environment specified below. The client or user of the system must ensure that it is used in such an environment.</p>			
Immunity test	Test level EN 60601-1-2	Compliance level	Electromagnetic environment - guidelines
Electro-static discharge (ESD) EN 61000-4-2	±8 kV contact ±15 kV air	±8 kV contact ±15 kV air	Hospital environment: Floors should be wood, concrete or ceramic tile. If floors are covered with synthetic material, the relative humidity should be at least 30%.
Radiated, radio-frequency, electromagnetic field IEC 61000-4-3	3V/m 80MHz to 2,7GHz	3V/m 80MHz to 2,7GHz	Portable and mobile RF communications equipment should be used no closer than 30 cm from any part of the system, including cables. <i>(see following paragraph 2.6.3).</i>
Electrical fast transient / burst EN 61000-4-4	±2kV for power lines ±1kV for input/output lines >3 m	±2kV for power lines ±1kV for input/output lines >3 m	Mains power quality should be that of a typical hospital environment.
Surge EN 61000-4-5	±1kV differential mode ±2kV common mode	±1kV differential mode ±2kV common mode	Mains power quality should be that of a typical hospital environment.
Immunity to conducted disturbances, induced by radio-frequency fields IEC 61000-4-6	3 V 150 kHz to 80 MHz 6V ISM frequencies	3 V 150 kHz to 80 MHz 6V ISM frequencies	Portable and mobile RF communications equipment should be used no closer than 30 cm from any part of the system, including cables. <i>(see following paragraph 2.6.3).</i>
Voltage dips, short interruptions and voltage variations on power supply input lines EN 61000-4-11	10 ms for 0% at 0°, 45°, 90°, 135°, 180°. 225°, 270°, 315° 20 ms for 0% at 0° 500 ms for 70% at 0° 5 s for 0%	10 ms for 0% at 0°, 45°, 90°, 135°, 180°. 225°, 270°, 315° 20 ms for 0% at 0° 500 ms for 70% at 0° 5 s for 0%	Mains power quality should be that of a typical industrial or hospital environment. We recommend fitting an UPS (uninterruptible power supply) if the user's system calls for continuous running even during power interruptions.
Power frequency magnetic field immunity (50/60Hz) EN 61000-4-8	30 A/m	30 A/m	If the monitor of the device shows signs of distortion in the images it will be necessary to position it further away from the source of the power frequency magnetic field or install a magnetic shield. The power frequency magnetic field must be measured in the new position so as to verify that the monitor is positioned far enough.

2.6.3 RECOMMENDED SEPARATION DISTANCES BETWEEN SYSTEM AND PORTABLE AND MOBILE RF COMMUNICATIONS EQUIPMENT

The system is intended for use in an electromagnetic environment in which radiated RF interference is controlled.

The client or user of the system can help prevent electromagnetic interference by maintaining a minimum distance between portable and mobile RF communications equipment (transmitters) and the system as recommended below, according to the maximum output power of the communications equipment.

Table 4

Test frequency (MHz)	Band (MHz)	Service	Modulation	Max power (W)	Distance (m)	Immunity level in test (V/m)
385	380 - 390	TETRA 400	Pulse modulation 18 Hz	1.8	0.3	27
450	430 - 470	GMRS 480 FRS 460	FM ~ 5 KHz deviation 1 KHz without	2	0.3	28
710	704 – 787	LTE Band 13, 17	Pulse modulation	0.2	0.3	9
745						
780						
810						
870	800 – 900	GSM 800/900 TETRA 800 IDEN 820 CDMA 850 LTE Band 5	Pulse modulation	2	0.3	28
930			18 Hz			
1720	1700–1990	GSM 1800CDMA 1900 GSM 1900 DECT LET Band 1, 3, 4, 25 UMTS	Pulse modulation	2	0.3	28
1845						
1970			217 Hz			
2450	2400-2570	Bluetooth, WLAN 802.11 b/g/n, RFID 2450, LET Band 7.	Pulse modulation 217 Hz	2	0.3	28
5240	5100-5800	WLAN 802.11 a/n	Pulse modulation	0.2	0.3	9
5500						
5785			217 Hz			

3 TECHNICAL DATA

3.1 DEVICE CLASS

Type of protection against electrical contacts:	Class I
Degree of protection against electrical contacts:	The system does not contain any patient applied parts
Degree of protection against water penetration:	Common equipment
Degree of safety in the presence of inflammable gases:	not suitable for use in the presence of inflammable gases
Operating conditions:	Continuous operation

3.2 TECHNICAL CHARACTERISTICS

3.2.1 MECHANICAL/ELECTRICAL DATA

C-ARM		
MECHANICAL DATA		
Motorized vertical stroke	- stroke: 450mm - speed: 1 cm/s	
Horizontal stroke	215 mm	
Wig-wag	± 12°	
Arc rotation around horizontal axis	± 275°	
C-arm sliding.	160°	
Focal spot / flat panel detector distance (S.I.D.)	FPD 3030	FPD 2121
	1080mm	1066mm
Flat panel detector / X-ray monoblock distance	808 mm (for models with FPD 2121) 821 mm (for models with FPD 3030)	
Arc depth	707 mm	
POWER SUPPLY		
Single-phase voltage	230 Vac ± 10%, 50Hz, 60 Hz	
	120 Vac ± 10%, 50Hz, 60 Hz	
Max consumption	- Fluoroscopy: 10 A (230 Vac) 16 A (120 Vac) - Radiography: 22 A	
Line resistance	max 0.4 Ohms	
Connector (conforms to IEC 309)	16 A	
ENVIRONMENTAL CONDITIONS		
Storage	- Temperature: -10 to +55 °C - Relative humidity: 20 - 70 % - Pressure: 70 - 106 kPa	
Working	- Temperature 10 - 35 °C - Relative humidity: 30 - 70 %	

X-RAY GENERATOR	
Code	IRI.37.203.001
Oscillation rate	40 kHz
Max voltage	120 kVp
Max current in pulsed fluoroscopy mode	50mA @ 100kV
Max current in continuous fluoroscopy mode	6mA @ 100kV
Current in radiography mode	50mA @ 100kV (0,1s)
Max current in radiography mode	100 mA
Max power for radiography	5kW (50mA @ 100kV 0,1s)

Note: for more details, see Paragraph 3.5 and 3.6 at the end of this Section.

X-RAY MONOBLOCK	
Model	I-40R 15 RF
Code	I01.01.138.001
Max power	20kW (200mA @ 100kV 0,1s)
Heat capacity	1020 kJ
Continuous heat dissipation (in air)	130W
Continuous heat dissipation (on C-arm)	150W
Total filtering	3mm Al _{eq} @ 70kV
Safety overload cut-out temperature	60°C ±5°C
Max charging time for X-ray monoblock in continuous fluoroscopy mode	60 min Duty cycle: 60 sec. ON – 60 sec. OFF @ 15i/s, 70 kV - 6 mA _{avg}
Compliance	EN 60601-1 and EN60601-2-28
Leakage Radiation	< 1 mGy/h @ 120kV-4mA continuous fluoro or 120kV-14400mAs Digital Rad

X-RAY TUBE	
Model	IAE RTM70H
Anode material	Rhenium/Tungsten/ Molybdenum
Focus	- Small focus: 0.3 mm - Large focus: 0.6 mm
Anode angle	10°
Anode heat capacity	225 kJ
Max anode heat dissipation	750 W
Nominal anode power	- Small focus: 6 kW - Large focus: 25 kW
Anode rotation	3000 rpm (50Hz) 3600 rpm (60Hz)

X-RAY COLLIMATOR with FPD 2121 ASI	
Model	R650 QDASM/010D + secondary collimator RS 2248
Square field (iris)	- Continuously adjustable aperture - Automatic adjustment to suit detector field - Manual control
Shutters	- Continuously adjustable aperture - Clockwise/anti-clockwise rotation, continuously adjustable - Manual control - Asymmetrical adjustable shutters
Max X-ray field	21 x 21 cm²
Additional X-ray beam filtering (4 possible conditions)	- No filter - 2mm Al - 1mmAl + 0,1mmCu - 1mmAl + 0,2mmCu

X-RAY COLLIMATOR with FPD 3030 ASI	
Model	R650 QDASM/010D
Square field (iris)	- Continuously adjustable aperture - Automatic adjustment to suit detector field - Manual control
Shutters	- Continuously adjustable aperture - Clockwise/anti-clockwise rotation, continuously adjustable - Manual control - Asymmetrical adjustable shutters
Max X-ray field	30 x 30 cm²
Additional X-ray beam filtering (4 possible conditions)	- No filter - 2mm Al - 1mmAl + 0,1mmCu - 1mmAl + 0,2mmCu

DOSE AREA PRODUCT METER (DAP) (optional)	
Model	KermaX plus (mod. 120-123c)
Power supply	DC: 12 - 29V (max 50mA)
Useful Area Diameter	93 mm
Sensitivity	1mGy x cm ²

LASER LOCALIZER Consisting of 4 laser modules (Optional) (optional)	
Model	ML635L in class 1M
Class	1M
Laser diode power	< 5 mW
Optical output power	3.8 mW
Wavelength	635 nm
Laser light warning	

3.2.2 IMAGING SYSTEM

FLAT PANEL DETECTOR		
Model	PaxScan 2121DXV	
FPD Matrix	1024 x 1024 pixel	
Sensitive area	<p style="text-align: center;">FLUOROSCOPY</p> <p style="text-align: center;">Nominal field= 205mm x 205mm (1004 x 1004 pixel) Zoom 1= 160mm x 160mm (780 x 780 pixel) Zoom 2= 120mm x 120mm (585 x 585 pixel)</p> <p style="text-align: center;">DIGITAL RADIOGRAPHY</p> <p style="text-align: center;">Nominal field= 205mm x 205mm (1004 x 1004 pixel)</p>	
Technology	Amorphous Silicon matrix	
Pixel size	205 µm	
Max frame rate	30 frame/s	
Resolution (limit)	2.43 lp/mm	
DQE @ 2 µ Gy, RQA5	0 lp/mm	80 %
	1.0 lp/mm	65 %
	2.0 lp/mm	40 %
MTF	IEC 1.0 lp/mm	55 %
	IEC 2.0 lp/mm	22 %
A/D conversion	16 bits	
Power supply	24 VDC - 12W	
Max dimensions	241mm x 241mm x 53.7mm	
Weight	3.2 kg	
Cooling	Passive	
Ambient Temperature	- Working: 15° - 58° - Storage: -20° - 70°	
Filtering of detector protective element	0.4 mm Al _{eq}	

FLAT PANEL DETECTOR		
Model	PaxScan 3030DXV	
FPD Matrix	1536 x 1536 pixel	
Sensitive area	<p style="text-align: center;">FLUOROSCOPY</p> <p style="text-align: center;">Nominal field= 294mm x 294mm (1516 x 1516 pixel) Zoom 1=209mm x 209mm (1082 x 1082 pixel) Zoom 2= 159mm x 159mm (824 x 824 pixel)</p> <p style="text-align: center;">DIGITAL RADIOGRAPHY</p> <p style="text-align: center;">Nominal field= 294mm x 294mm (1516 x 1516 pixel)</p>	
Technology	Amorphous Silicon matrix	
Pixel size	194 µm	
Max frame rate	30 frame/s	
Resolution (limit)	2.58 lp/mm	
DQE @ 2 µ Gy, RQA5	0 lp/mm	80 %
	1.0 lp/mm	65 %
	2.0 lp/mm	44 %
MTF	IEC 1.0 lp/mm	55 %
	IEC 2.0 lp/mm	23 %
	IEC 2.58 lp/mm (Nyquist Frequency)	15 %
A/D conversion	16 bits	
Power supply	24 VDC - 15W	
Max dimensions	338mm x 328mm x 57.6mm	
Weight	5.6 kg	
Cooling	Passive	
Ambient Temperature	- Working: 15° - 58° - Storage: -20° - 70°	
Filtering of detector protective element	0.4 mm Al _{eq}	

ANTI-SCATTER GRID	
Manufacturer	JPI
Model	ACS
Dimensions	215 mm x 215 mm (with FPD 2121) 315 mm x 315 mm (with FPD 3030)
Interspace	Aluminum
Ratio	8:1
Shutters	80 lines/cm
Focal distance	100 cm
Attenuation ratio (expressed as 1/transmission of primary radiation =1/0.7)	1.42

TV MONITOR	
Model	GUP2762AMII-P
Technology	27" color LCD
Resolution	2560 x 1440 (4k)
Contrast ratio	1000:1
Brightness	350 cd/m ² (max)
Viewing angle	Vertical and horizontal 178°
Power supply	110-230 VAC
Max consumption	60 W
Dimensions	651 x 402 x 69 mm
Weight	11.8 Kg

CONTROL PANEL	
Model	MUIP-2112
Technology	LCD 12,5" color, Touch screen
Effective display area	276,5 mm x 157,5 mm
Resolution	1920 x 1080 pixel
Contrast ratio	Max 1000:1
Brightness	400 cd/m ² (typ)
Viewing angle	Vertical and horizontal: 80 °
Touch screen	P-Cap Multitouch 10-point (usable with surgical gloves)
Processor	CPU Intel Celeron N2930 (Quad core 1,83 Ghz, 2Mb cache)
SDRAM	4GB DDR3L 1333MHz RAM
Memory	32GB SATA onboard SSD
Ethernet	2 x Built-in Gigabit Ethernet LAN interfaces
USB	- 1 USB 2.0 port type A - 1 USB 3.0 port type A
Operating System	Microsoft: Windows 10 LTSB
Power supply	Range 12-24Vdc, nominal 19Vdc

VIDEO PROCESSOR	
CPU	Intel i7-8700 3,2GHz 6 core Coffee Lake
Operating System	WINDOWS 10 IoT Enterprise 2019 LTSC (ESD) ENG 64bit
Video board	PCI-e 16x ASUS Model ROG-STRIX-GTX1650-04G
Ethernet interface board	Intel Model: I210-T1
RAM	16GByte
Hard Disk	2 HARD DISKS SSD 512GB PCIe NVMe
Interface	<ul style="list-style-type: none"> - USB (for Windows compatible printer) - USB (for saving images to USB memory stick) - RJ45 (for DICOM 3 interface)
Acquisition	<ul style="list-style-type: none"> - Resolution matrix: 1516 x 1516 pixels (max) - Image depth: 16 bits - Speed: max 30 frames/second
Details of saved images on HD	<p><u>Detector 3030DXV:</u></p> <ul style="list-style-type: none"> - field 30 x 30 cm²: 1516 x 1516 pixels (1 - 8fps) 758 x 758 pixels (15 - 30fps) - field 21x21 cm²: 1082 x 1082 pixels - field 16x16 cm²: 824 x 824 pixels <p><u>Detector 2121DXV:</u></p> <ul style="list-style-type: none"> - field 21x21 cm²: 1004 x 1004 pixels - field 16x16 cm²: 780 x 780 pixels - field 12x12 cm²: 585 x 585 pixels <ul style="list-style-type: none"> - Grey scale depth: 16 bits unsigned - Little Indian byte order
Image processing in real time	<ul style="list-style-type: none"> - Reduction of quantum noise via recursive filter Motion sensitive - DRC (Dynamic Range Compression), digital process to optimize image and contrast latitude - Edge enhancement/reduction (sharp/smooth), with specific kernel settings (from 3 x 3 to 9 x 9 pixels). - Grey scale inversion (negative) - Horizontal image flip. - Digital image rotation (steps of 1°). - Automatic Gain Control (AGC): automatic control of the images Window and Level. - L.I.H (Last Image Hold): the last acquired image is saved in RAM. - DSA functions: * <ul style="list-style-type: none"> - Images subtraction - Max Opacification / Road Mapping

VIDEO PROCESSOR	
Post-processing functions	<ul style="list-style-type: none"> - Patient data entry - Cine-loop of acquired run - Contrast / Brightness control (W and L) - Edge enhancement/reduction (sharp/smooth), with specific kernel settings (from 3 x 3 to 9 x 9 pixels). - DRC (Dynamic Range Compression), digital process to optimize image and contrast latitude - Grey scale inversion (negative) - Multiframe display (max 6) - Electronic shutters - Virtual shutters - Angle/distance measurements - Text entry (free or fixed strings) - Printouts using Windows compatible printer - Saving of images to USB memory stick in DICOM format - DSA functions: * <ul style="list-style-type: none"> - Mask pick-up - Pixel Shift - Land marking - Catheter calibration
DICOM functions (*)	<ul style="list-style-type: none"> - Importing of studies to be performed from the "Worklist SCU" service - Sending of images via the "Store SCU" service - Sending of images to be printed via the "Print SCU" service - Management of studies via the "MPPS SCU" service - Confirmation of image storing via the "Storage Commitment SCU" service - Management of the patient dose via the "Dose Structured Report SCU" service - Request for images via the "Query / Retrieve SCU" service

(*) Optional

3.2.3 EXPOSURE MODES

For a full description of the exposure modes:

- **Low Dose** fluoroscopy
- **High Quality** fluoroscopy
- **Radiography**
- mAs table
- kV/mA correlation
- Dose information

see Paragraph 1.4, Part 1 of this Manual.

For a full description of the exposure modes:

- Roadmap
- DSA Fluoroscopy

see Paragraphs 4.1 and 4.2, Part 2 of this Manual.

3.2.4 ACCURACY OF LOADING FACTORS

The accuracy of all loading factors is given in the following table.
 Uncertainty values are compliant with standard **EN 60601-2-54 + A2: 2018**.

Radiological parameters accuracy	
Tube voltage deviation (kV) in Fluoroscopy modes and Digital Radiography	± 8%
Tube current deviation in Fluoroscopy modes (mA)	± 20%
Current time product in Digital Radiography (mAs)	± 10% + 0,2 mAs
Loading time	± 10% + 1 ms

3.3 OVERALL DIMENSIONS AND WEIGHTS

Versions with **FPD 2121**

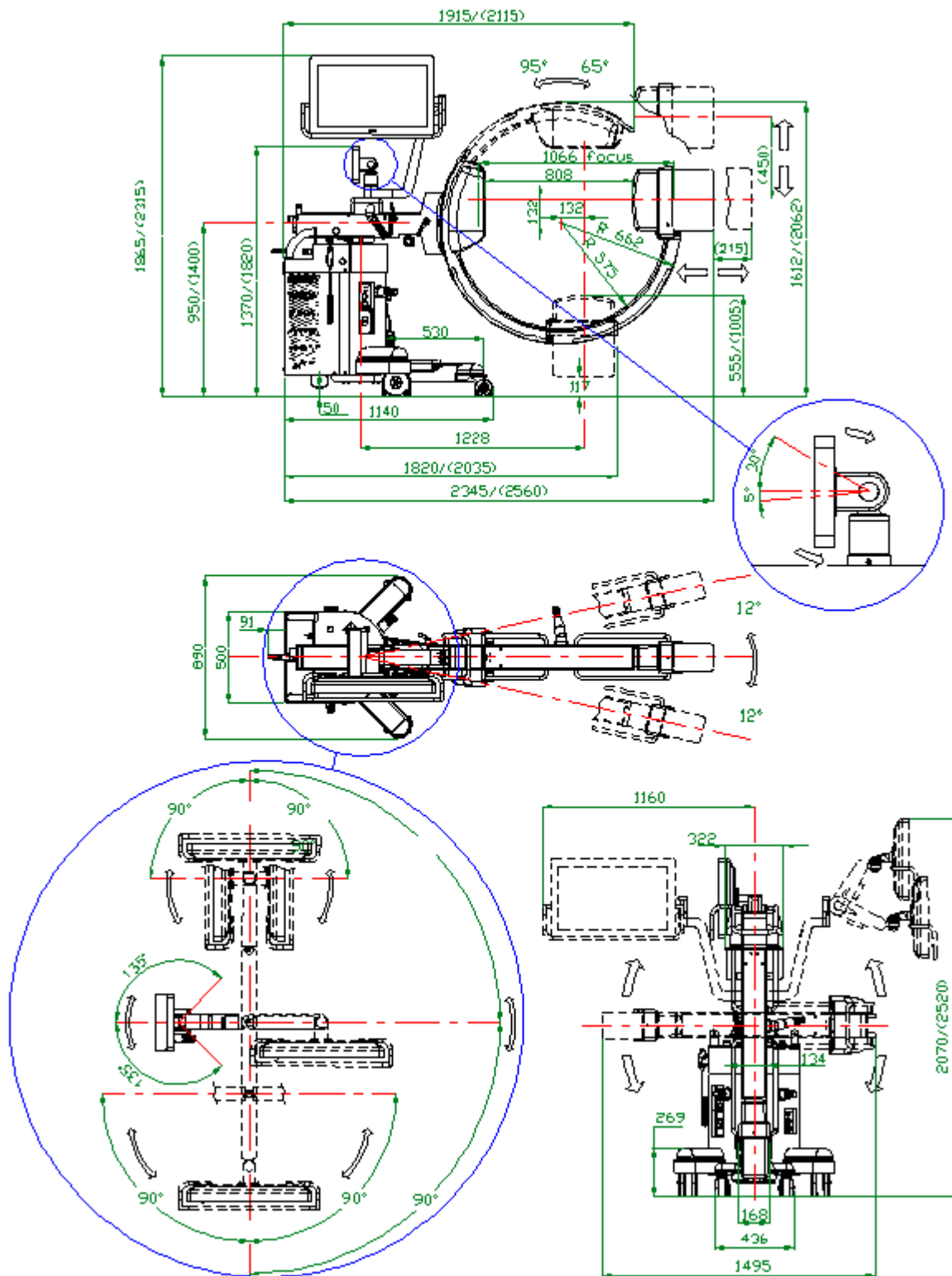

Note: Dimensions shown in mm

Weight: **310 kg**

Versions with **FPD 3030**

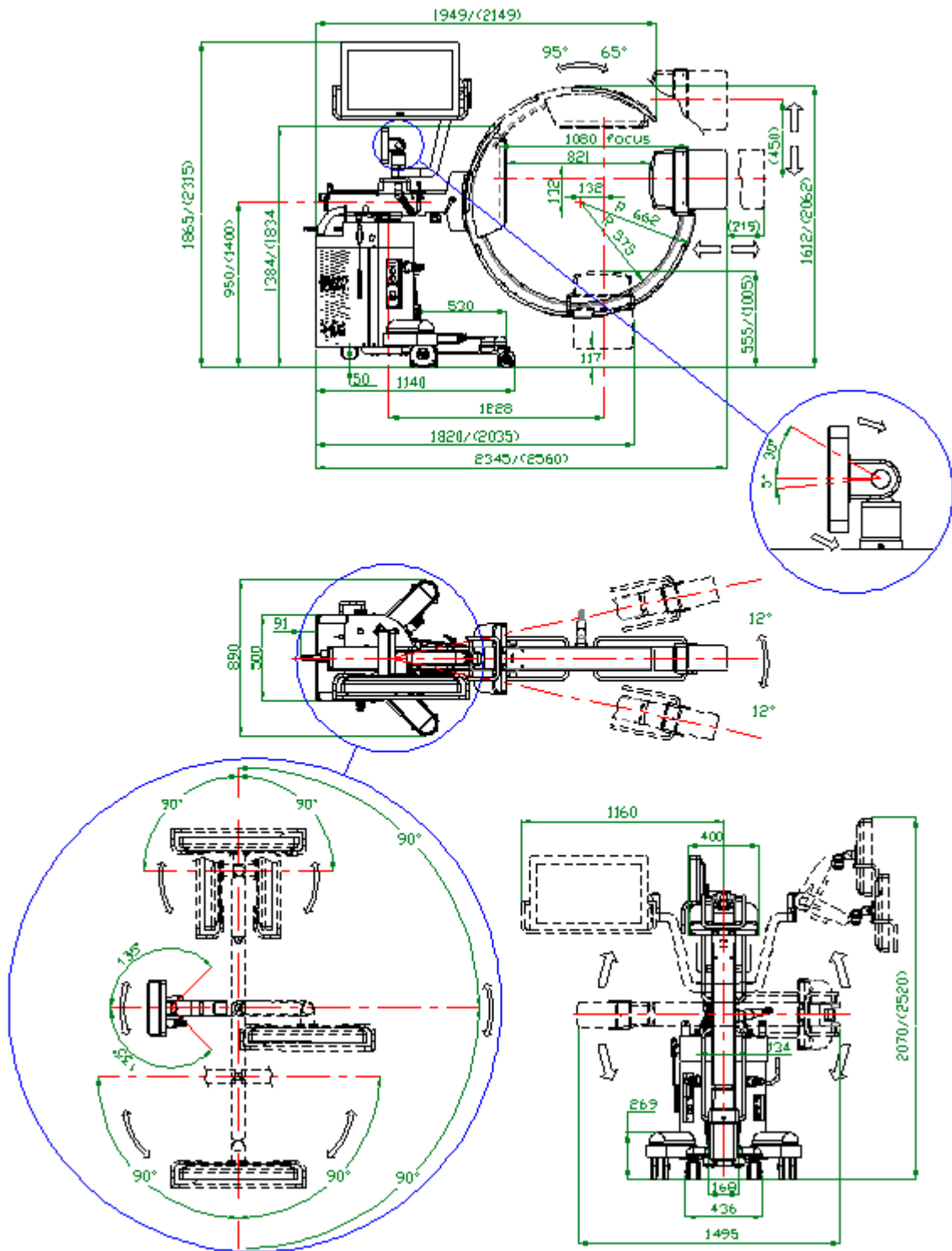

Note: Dimensions shown in mm

Weight: **310 kg**

3.4 FOCAL SPOT POSITION

Versions with **FPD 2121**

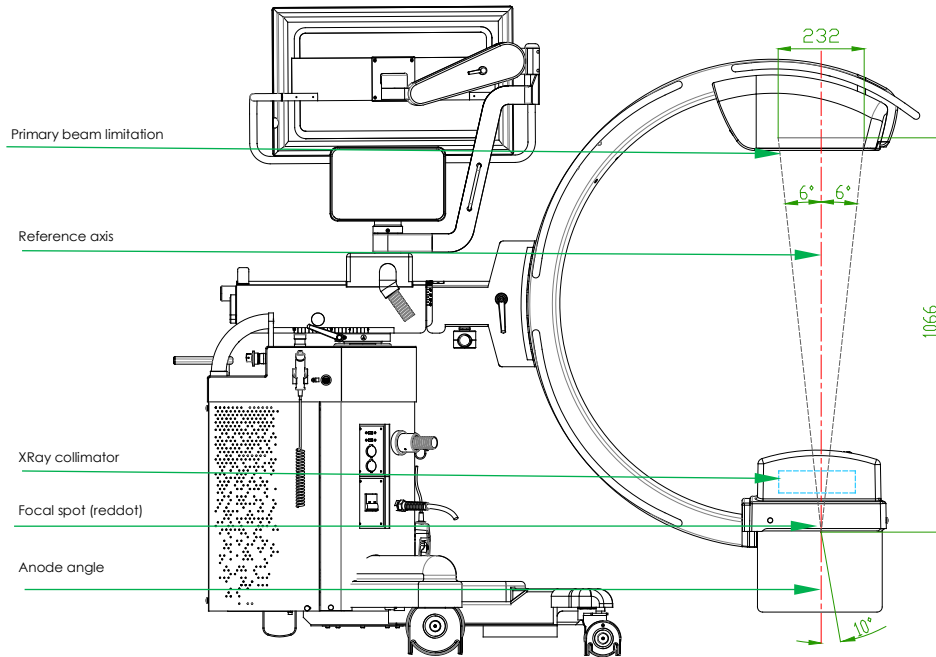

Version with **FPD 3030**

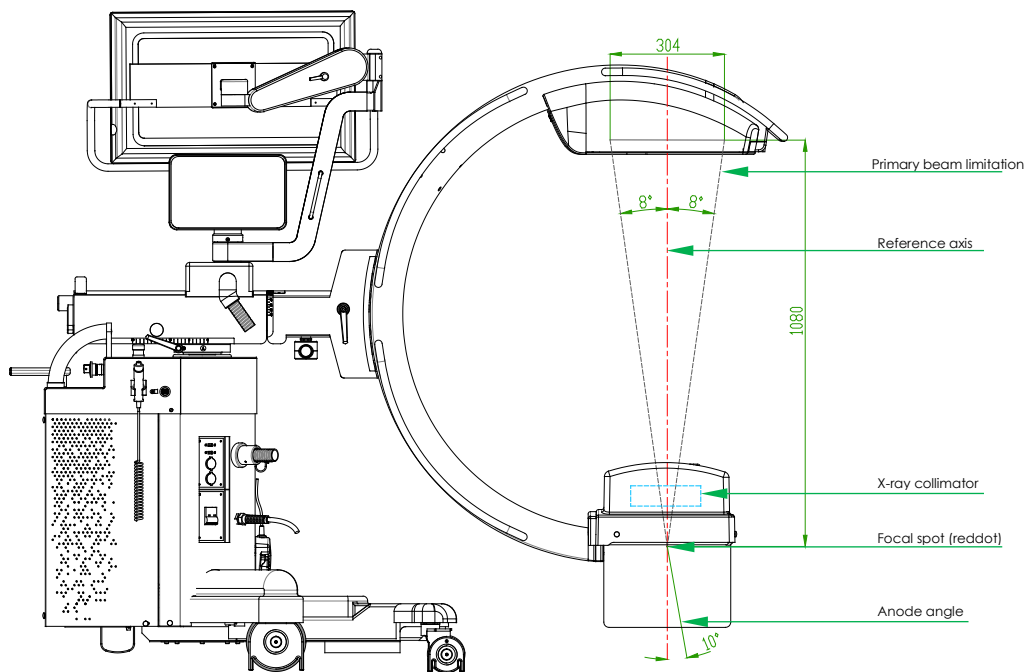

3.5 FLUOROSCOPY mA CURVES

ACQUISITION RATES: ≤ 15 FPS

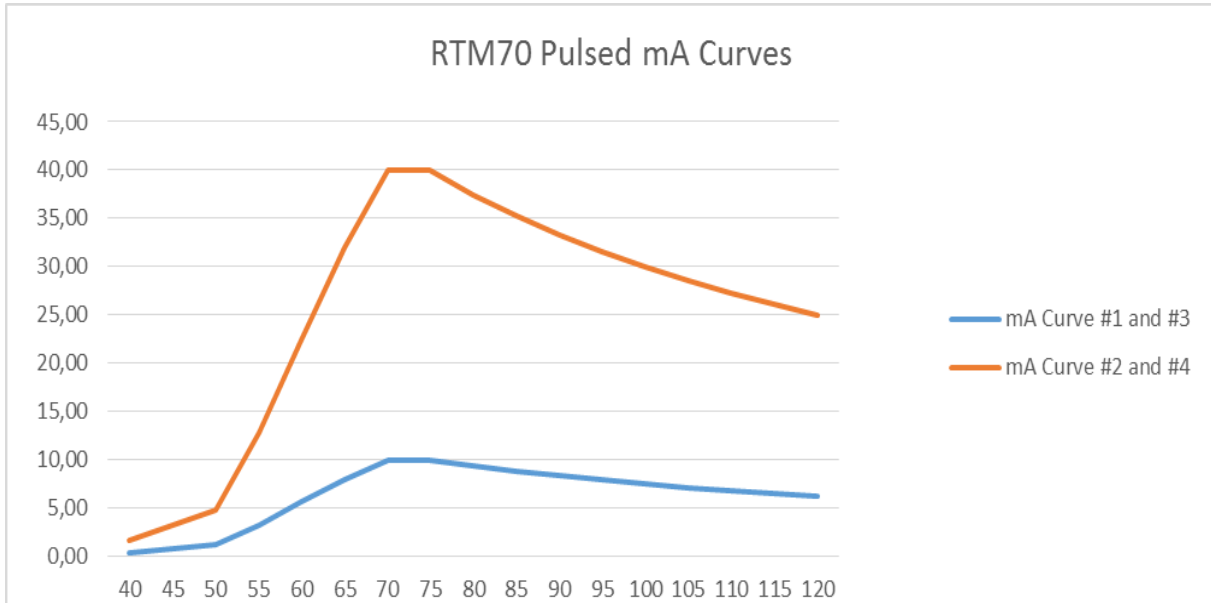

ACQUISITION RATES: 30 FPS

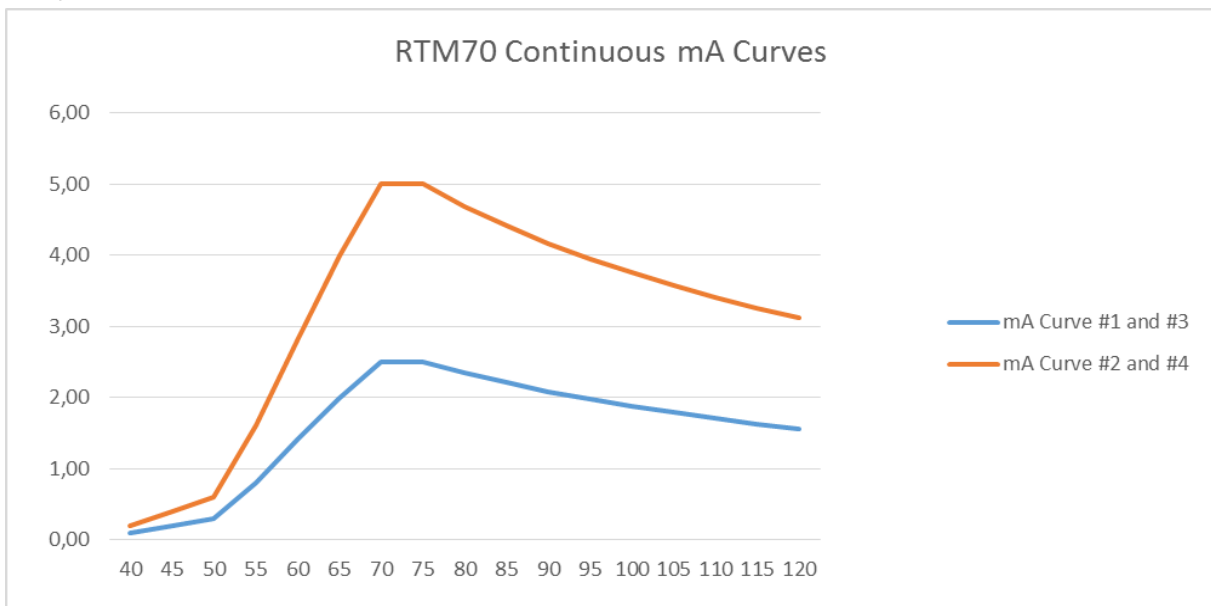

3.6 DIGITAL RADIOGRAPHY (SNAPSHOT) mA CURVES

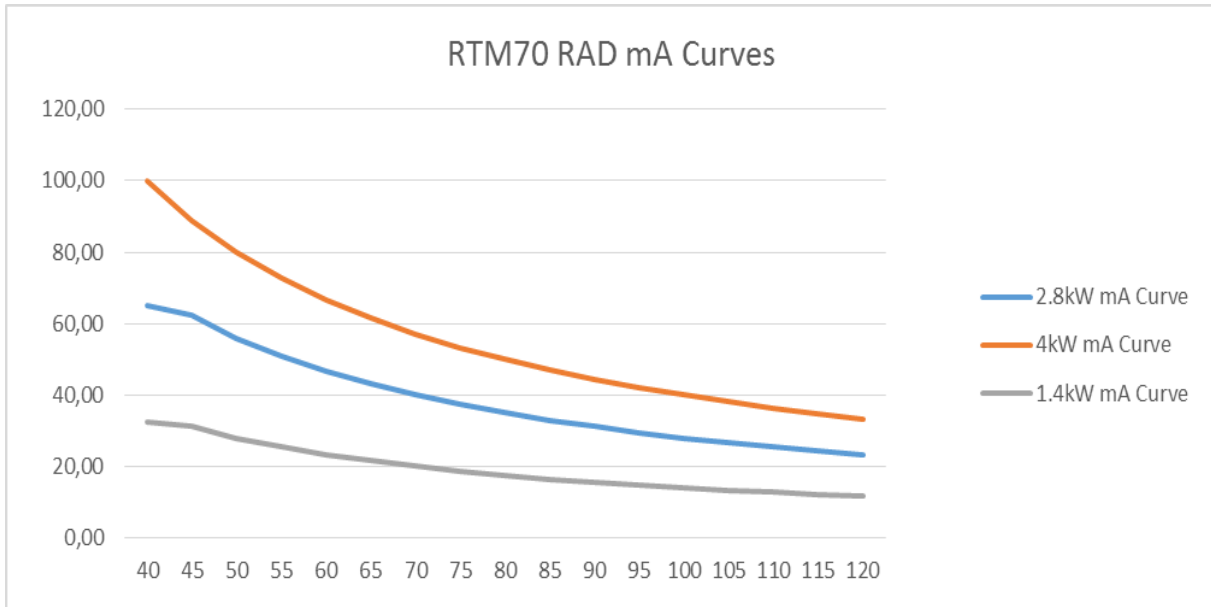

3.7 X-RAY TUBE IAE RTM70H CURVES

Anode heating and cooling curves

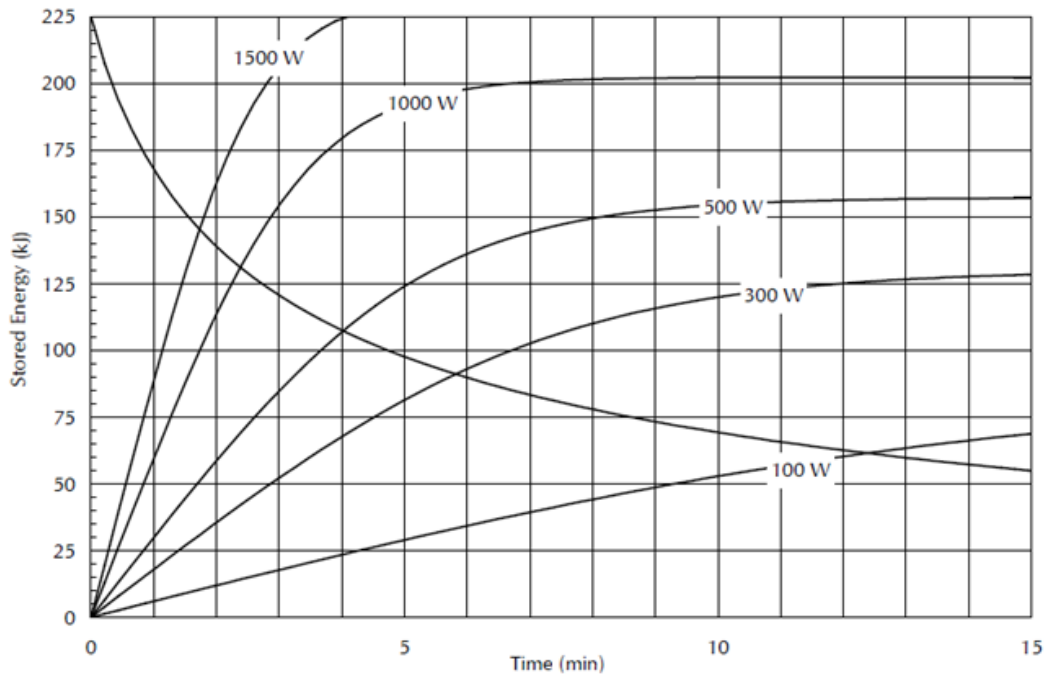

Cathode emission characteristic (small focus)

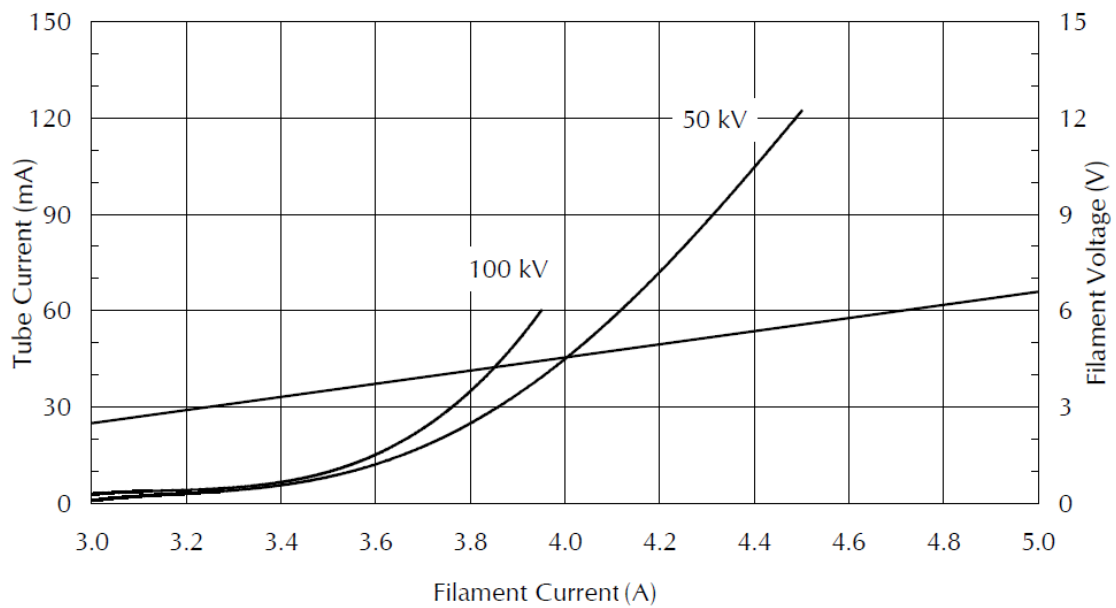

Cathode emission characteristic (large focus)

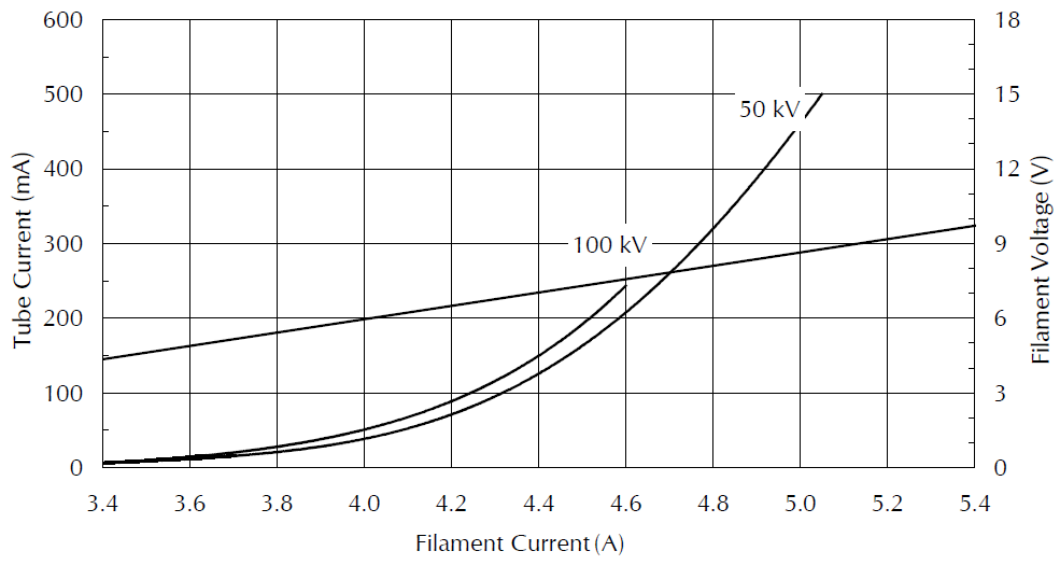

3.8 X-RAY MONOBLOCK I-40R 15 RF CURVES

Monoblock heating curves

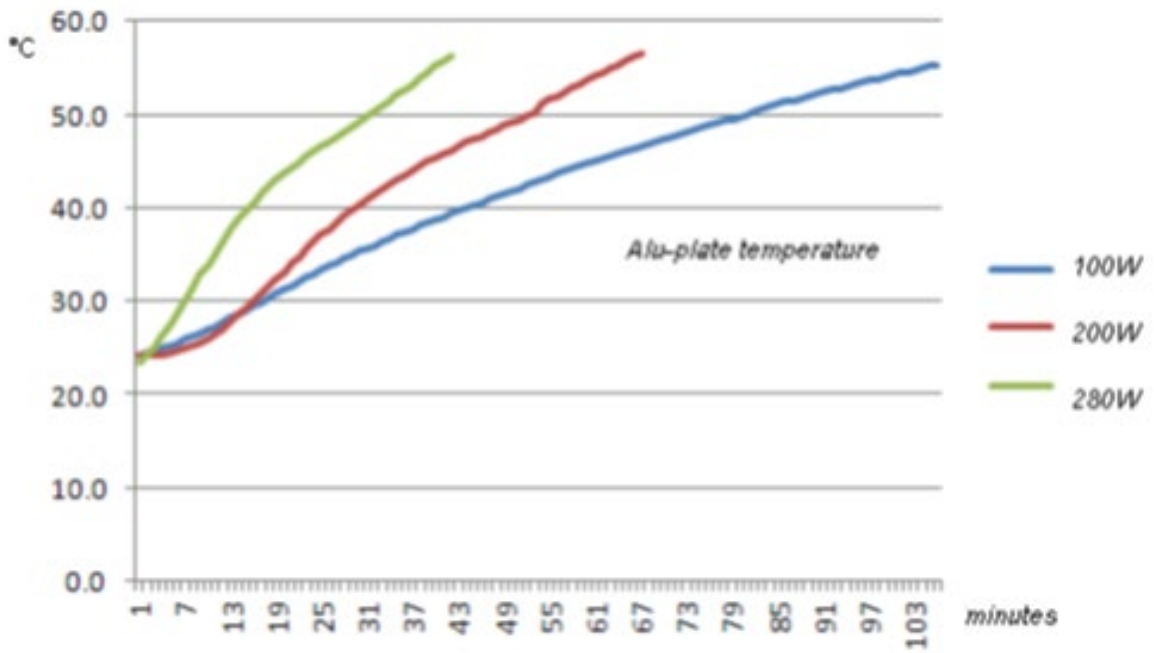

Monoblock cooling curves

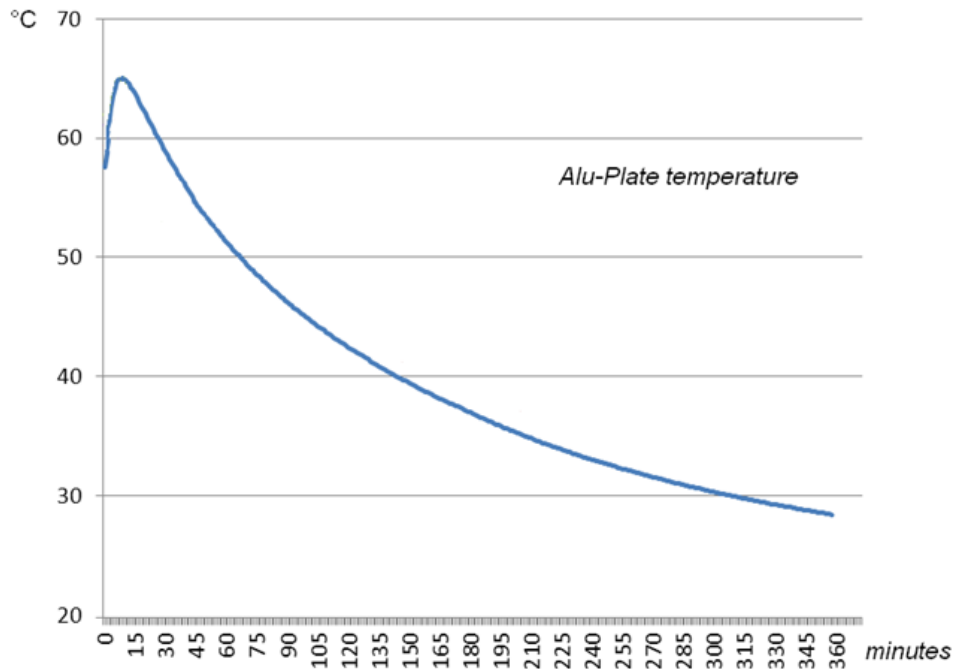

Part 2 : USE

CONTENTS

	pages	rev.	Date
CONTENTS	1.1 – 1-3	A	21/03/22
1 INSTRUCTIONS AT START AND END OF USE	1.1 - 1.47	0	01/03/21
1.1 Fuses			
1.2 Switching-on the EM equipment			
1.2.1 Mains failure			
1.2.2 Login			
1.2.3 Checking the monitor adjustments			
1.3 Positioning			
1.3.1 Positioning of the C-arm			
1.3.2 Moving the equipment			
1.3.3 Insert/remove the anti-scattering grid			
1.4 Video processor setup			
1.4.1 Introduction			
1.4.1.1 Login			
1.4.2 General settings			
1.4.3 Unit configuration			
1.4.4 Anatomical exam setup			
1.4.4.1 Programmable parameters			
1.4.4.2 Image processing			
1.4.5 Exams management			
1.4.5.1 Organize the exam list			
1.4.6 Fixed string setup			
1.4.7 User account setup			
1.4.8 Firewall info			
1.5 Patient dose information			
1.5.1 Measuring the dose			
1.6 Dispersed radiation in occupied areas			
1.7 Isokerma maps			
1.7.1 Vertical placement			
1.7.2 Horizontal placement			
1.8 Daily checks			
1.8.1 Checking the dose level			
1.8.2 Checking the dose area product (DAP)			
1.8.3 Checking the max X-ray collimator aperture			
1.8.4 Checking the safety of the motorized up/down C-arm movement			
1.8.5 Checking the monitor adjustments			
1.9 End of use			
1.10 Parking and moving			
2 INSTRUCTIONS FOR USE	2.1 - 2.40	A	21/03/22
2.1 Operator authentication (login)			
2.2 Opening a study			
2.2.1 Study List frame			
2.2.1.1 Study Worklist (optional)			

- 2.2.1.2 Study List
- 2.2.1.3 Query/Retrieve List (optional)
- 2.2.2 Online manuals
- 2.2.3 Creating a new study
- 2.2.4 Opening a study
 - 2.2.4.1 Detector dark calibration
- 2.2.5 Selecting an exam type
 - 2.2.5.1 Preset exams
- 2.3 Image acquisition
 - 2.3.1 Selecting the acquisition mode
 - 2.3.2 Acquisition rates
 - 2.3.3 Low Dose fluoroscopy
 - 2.3.4 High-Quality Fluoroscopy
 - 2.3.5 Digital radiography
 - 2.3.6 X-ray timer
 - 2.3.7 Heat unit count
 - 2.3.8 Flat panel detector zoom fields
 - 2.3.9 Image rotation / flip
 - 2.3.10 X-ray collimator
 - 2.3.10.1 Virtual collimator display
 - 2.3.11 Stopwatch function
 - 2.3.12 Sight function
 - 2.3.13 Reference image
- 2.4 Finding and viewing images
 - 2.4.1 Finding images
 - 2.4.1.1 Single image
 - 2.4.1.2 Multiframe run
 - 2.4.2 Viewing multiple images

3 POST-PROCESSING OF IMAGES

3.1 - 3.18

0 01/03/21

- 3.1 Introduction
 - 3.1.1 Acquired image details
 - 3.1.2 Live drawing function
- 3.2 Image processing
- 3.3 Image orientation
- 3.4 Electronic shutters
- 3.5 Flagging images
- 3.6 Deleting images
- 3.7 Image records
 - 3.7.1 Direct print-outs (optional)
 - 3.7.2 Dose report image
- 3.8 Entering text
- 3.9 Graphic functions
 - 3.9.1 Measurements - ruler
 - 3.9.1.1 Calibration
 - 3.9.2 Measurements - angle
 - 3.9.3 Graphic objects
 - 3.9.4 Magnifying glass
 - 3.9.5 Pixel manager
- 3.10 Quitting the study

<p>4 DIGITAL SUBTRACTION ANGIOGRAPHY (DSA)</p> <p>4.1 Introduction</p> <p>4.2 Roadmap</p> <p>4.3 DSA fluoroscopy mode</p> <p> 4.3.1 Injector</p> <p> 4.3.2 DSA acquisition with fixed pulse rate</p> <p> 4.3.3 DSA acquisition without automatic mask pick-up</p> <p>4.4 DSA post-processing</p> <p> 4.4.1 Description of the angiographic functions</p>	<p>4.1 - 4.13</p>	<p>A</p>	<p>21/03/22</p>
<p>5 MAINTENANCE AND PRODUCT DISPOSAL</p> <p>5.1 Routine maintenance</p> <p> 5.1.1 General recommendations</p> <p> 5.1.2 User controls and inspections</p> <p>5.2 Cleaning and disinfecting</p> <p> 5.2.1 Microbic contamination</p> <p>5.3 Replacing batteries</p> <p> 5.3.1 Replacing the remote-control battery</p> <p> 5.3.2 Replacing wireless footswitch batteries</p> <p> 5.3.3 Replacing the backup battery on the motherboard</p> <p>5.4 X-ray tube seasoning procedure</p> <p>5.5 Product disposal</p> <p> 5.5.1 Procedures and precautions</p>	<p>5.1 - 5.8</p>	<p>A</p>	<p>21/03/22</p>
<p>6 ANNEXES</p> <p>6.1 Changing the interface language</p> <p>6.2 Using the keyboard on the touch screen monitor</p> <p>6.3 Adjusting the monitors</p> <p>6.4 Study List Manager</p> <p> 6.4.1 Searching a study</p> <p> 6.4.2 Selecting multiple studies</p> <p> 6.4.3 Deleting a study</p> <p> 6.4.3.1 Protecting a study against deletion</p> <p>6.5 Transferring images via DICOM</p> <p> 6.5.1 Store DICOM</p> <p> 6.5.2 Print DICOM</p> <p> 6.5.3 DICOM Spooler</p> <p>6.6 Saving images to USB device</p> <p>6.7 Radiation dose structured report (R.D.S.R.) (optional)</p> <p>6.8 Query / retrieve (optional)</p> <p>6.9 Changing the user password</p> <p>6.10 Anatomical exam setup</p> <p>6.11 Software glitches</p> <p>6.12 Connection of an auxiliary monitor</p> <p>6.13 Local Printer (optional)</p> <p> 6.13.1 Loading the paper</p>	<p>6.1 – 6.29</p>	<p>A</p>	<p>21/03/22</p>

1 INSTRUCTIONS AT START AND END OF USE

1.1 FUSES

The power circuit of the EM equipment is protected by a magnetothermal circuit-breaker.

Simply reset the magnetothermal circuit-breaker if it trips.

If the magnetothermal circuit-breaker trips again immediately after resetting, the EM equipment is malfunctioning: call Technical Service.

The EM equipment is completely cut off from the mains supply when the magnetothermal circuit-breaker trips (both electrical poles are separated).

The EM equipment can be supplied ready for a mains power supply of **230 VAC** or **120 VAC**, with a specific circuit breaker as indicated in the following table:

Characteristics of the circuit breaker:

120 Vac Version	
Tripping type	Type D
Tripping current	16A
Number of poles	2
Tripping power	10kA
Nominal AC voltage	400V

230 Vac Version	
Tripping type	Type D
Tripping current	10A
Number of poles	2
Tripping power	10kA
Nominal AC voltage	400V



1.2 SWITCHING-ON OF THE EM EQUIPMENT

1. Connect the equipment to the power supply:

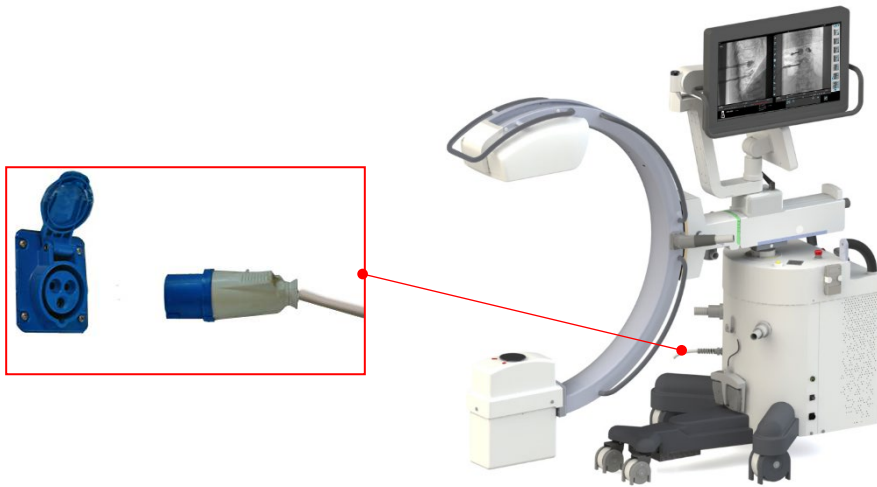

Warning: Use only earthed-approved sockets, in compliance with EM equipment supply (120 VAC or 230 VAC). The resistance in the socket outlet must conform to supply specifications reported at Paragraph 1.1.2, Section 1 of this Manual.

2. Connect the X-ray command footswitch:

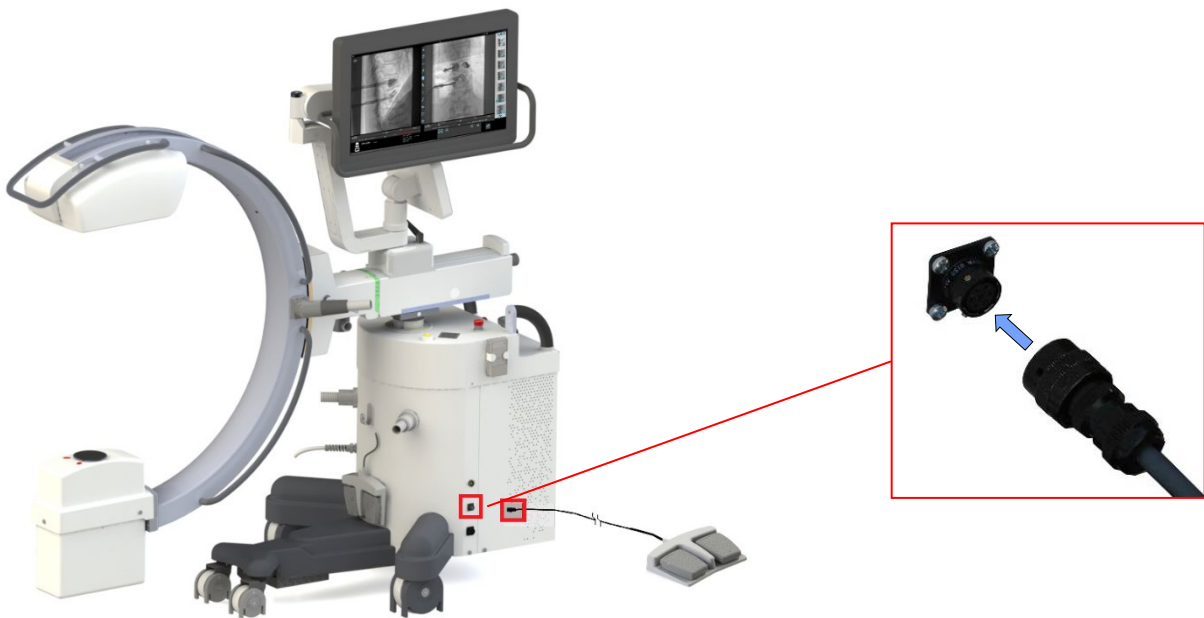

3. Connect the patient bed (not supplied with the EM equipment) to the equipotential earth connector on the stand:



4. Switch the magneto-thermal circuit-breaker to **ON (I)**.



5. Set the key switch to **ON (Symbol I)**. This turns on the equipment.

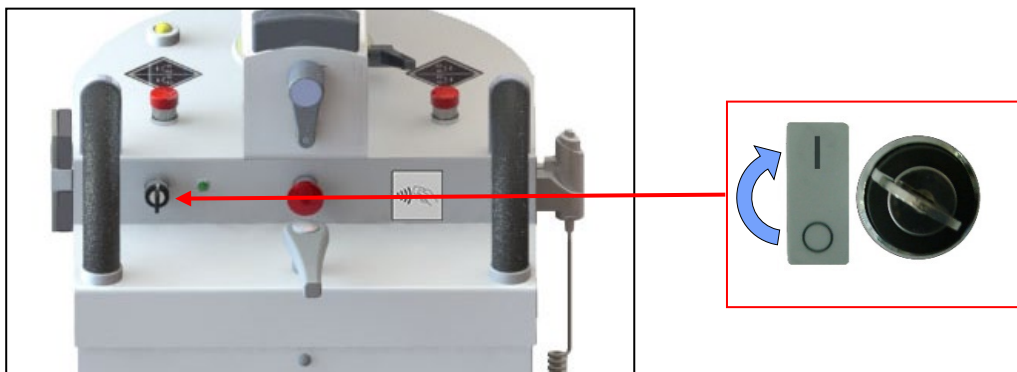

It activates the equipment initialization phases, shown on Control Panel and on monitor.

Note: In case you are required to reboot the equipment, turn it off and wait at least 10 seconds before to switch it on again.

1.2.1 MAINS FAILURE

The equipment automatically shuts down in the event of an interruption to its power supply (even if transitory).

When the power returns, the equipment will automatically turn on (if the key switch on the stand is still turned ON).

Note: *If this interruption happens during an acquisition, related images will not be shown within the study you were performing, but they have been saved in hard disk, anyway. To restore these images, it is required the Technical Service intervention.
Dose data related to these images, instead, are not recoverable.
If the interruption happens while sending images through DICOM network, when the equipment turns on, it will be possible to restart the procedure directly by the spooler.*

1.2.2 LOGIN

After the initialization phase, the equipment will ask the operator to log in, which can be done either on the monitor or on the Control Panel.

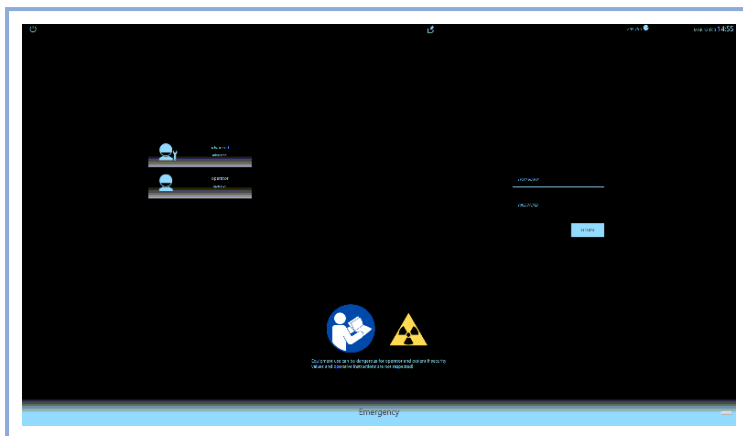

Monitor

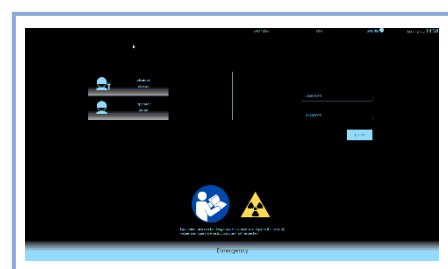

Control Panel

Note: *a detailed login procedure description can be found in Paragraph 2.1, Part 2 of this Manual.*

1.2.3 CHECKING THE MONITOR ADJUSTMENTS

After the operator login (by entering the **user name** and **password** agreed with the person in charge of the equipment), the monitor displays a test pattern that lets you check their correct brightness and contrast adjustments



Main Monitor

Note: for detailed operation information, please refer to Paragraph 2.1, Part 2 of this Manual.

After confirming the monitor settings, the monitor and Control Panel will display the worklist with the studies to be carried out:



Main Monitor



Control Panel

1.3 POSITIONING

 Never attempt to move the equipment when the brakes are on. Always use the respective handles to move the equipment.

Switch on the equipment.

1.3.1 POSITIONING OF THE C-ARM

1. Engage the parking brakes on the stand (A) as shown in the picture.

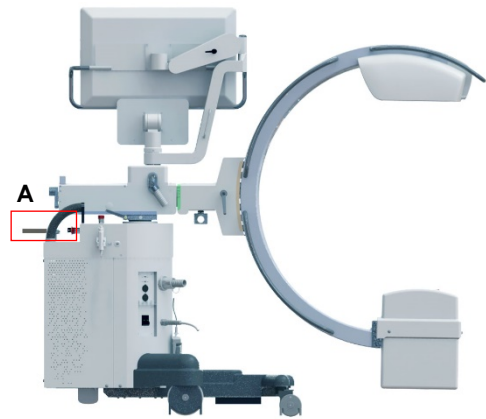
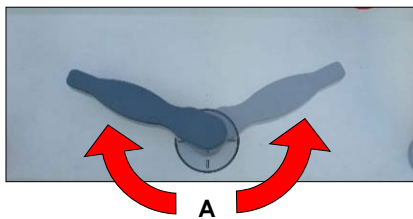

2. Adjust the **height** of the C-arm using the keys as shown in the figure below.
 This operation is only possible when the equipment is switched on.

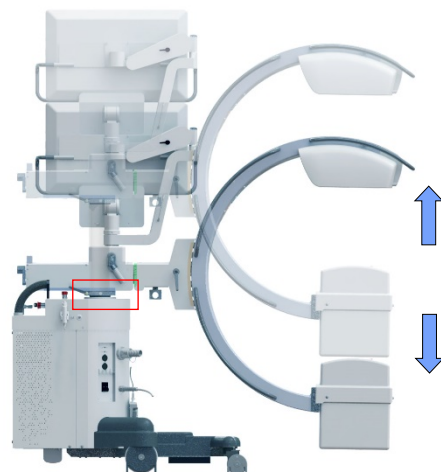
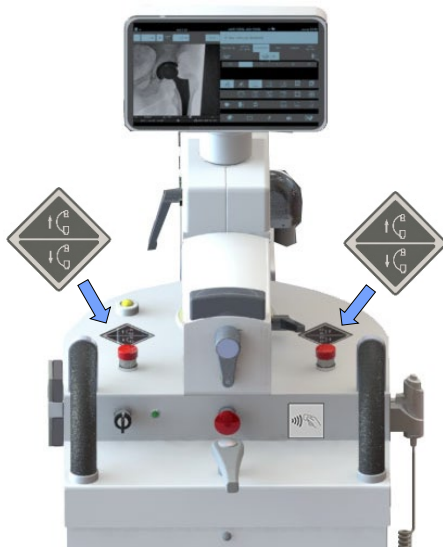

Warning: Before using the C-arm up and down movement, be sure that it cannot collide with people and/or objects

3. Adjust the **longitudinal** movement with the handle shown.
Brake shown in **purple**.

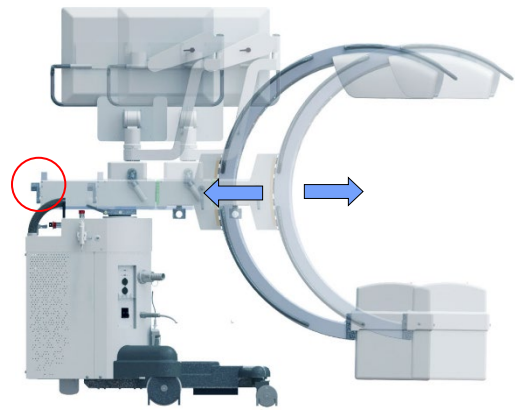
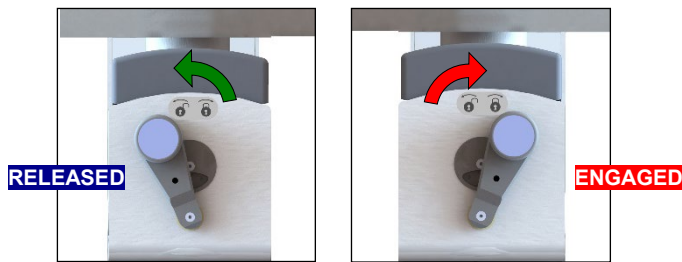

Warning: Before moving the C-arm, be sure that it cannot collide with people and/or objects.

4. Adjust the **wig-wag** of the C-arm.
Brake shown in **yellow**

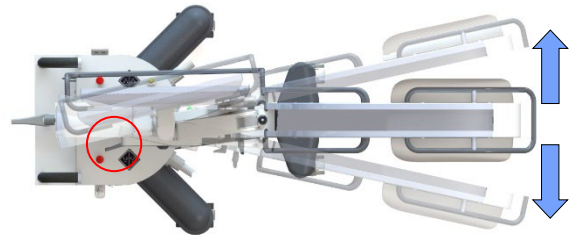
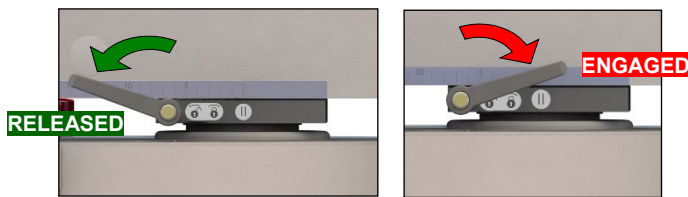

Warning: Before moving the C-arm, be sure that it cannot collide with people and/or objects.

5. Adjust the **rotation** of the C-arm (the goniometer scale indicates the angle of rotation).
Brake shown in **Green**

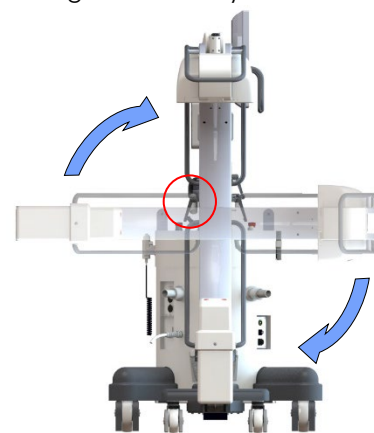
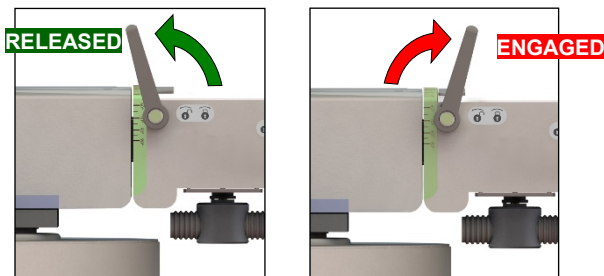

Warning: Before rotating the C-arm, be sure that it cannot collide with people or objects.

6. Adjust the **angle (orbiting)** of the C-arm.
 Brake shown in **Pink** 

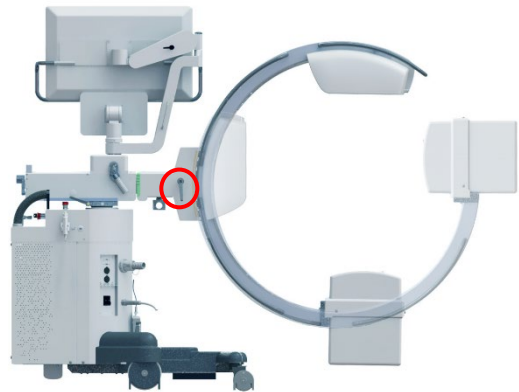
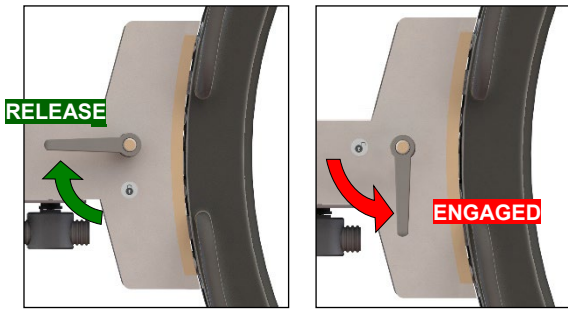

Warning: Before moving the C-arm, be sure that it cannot collide with people and/or objects.

The scale on the inside of the C-arm indicates the angle of rotation with respect to the vertical position (0°).

7. You can now enable the laser localizer (*optional*) by pressing the corresponding key on the stand control panel (the laser beams will remain lit for one minute or until you press the key again).

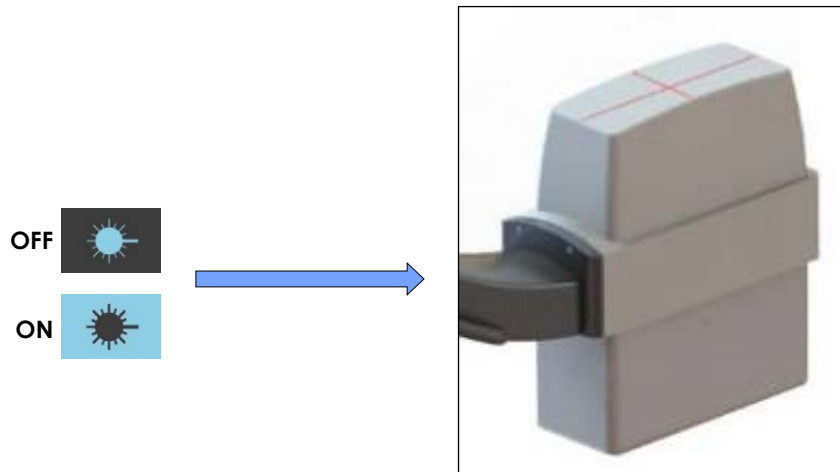

All brakes must be engaged after positioning.

1.3.2 MOVING THE EQUIPMENT



Warning: Before moving the equipment:

- make sure that it cannot collide with people and/or objects.
- Hook the monitor handle into the designated retaining support and activate the brake of the support arm in order to prevent any uncontrolled movement.

The stand is fitted with guided rear wheels and free wheels at the front. The rear wheels are steered using the guide lever shown in the figure below.

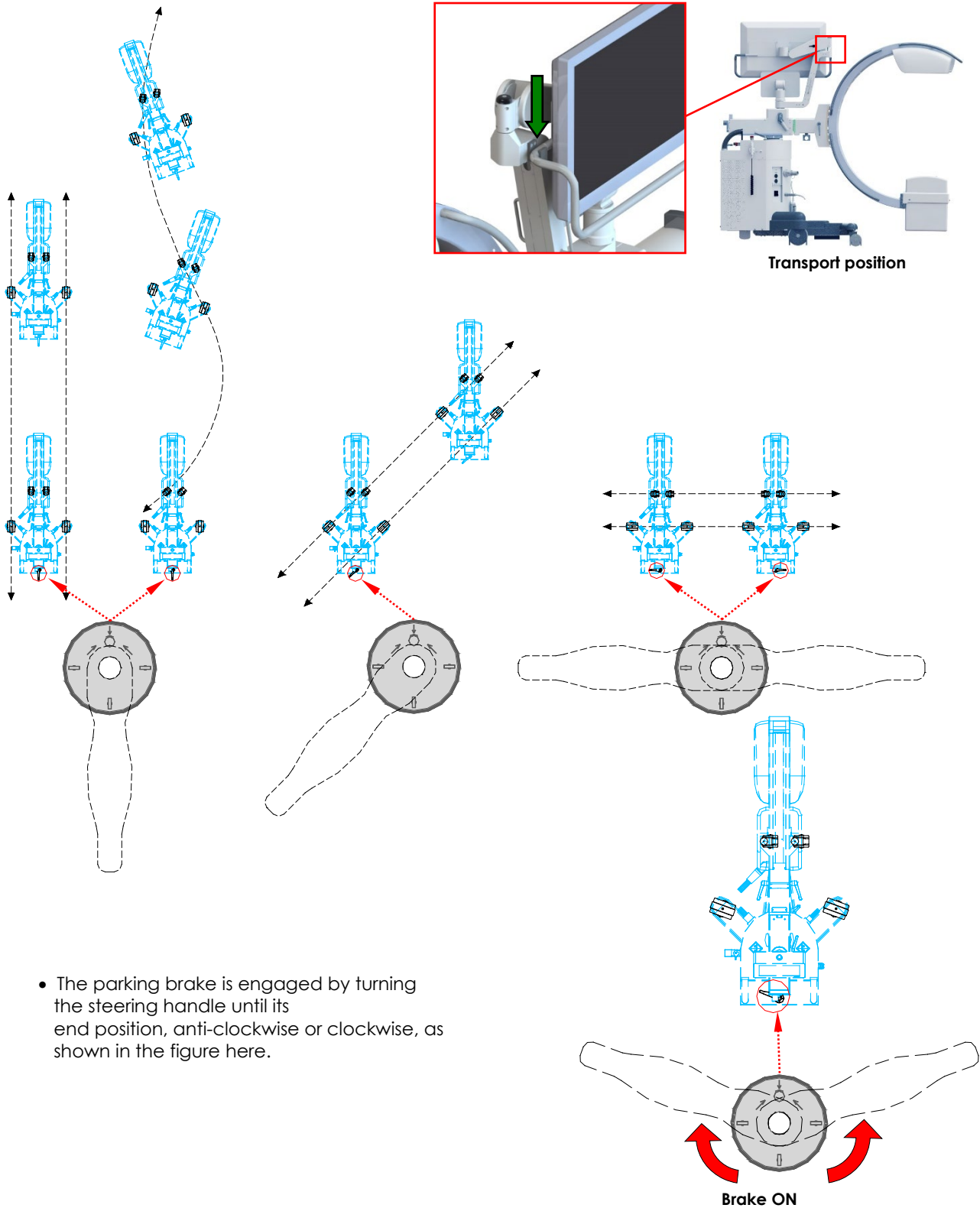

- The parking brake is engaged by turning the steering handle until its end position, anti-clockwise or clockwise, as shown in the figure here.

1.3.3 INSERT/ REMOVE THE ANTI-SCATTERING GRID

Before inserting/extracting the anti-scattering grid into/from the dedicated receptacle, position the equipment with the FPD at the top; if necessary, lower the C-arm so as to make the removal easier.



Warning: Do not insert/extract the anti-scattering grid when the system is in any position other than the transport position, as the grid could fall and be damaged.

- Grab the handle **(M)** as indicated by the arrow in Fig.2

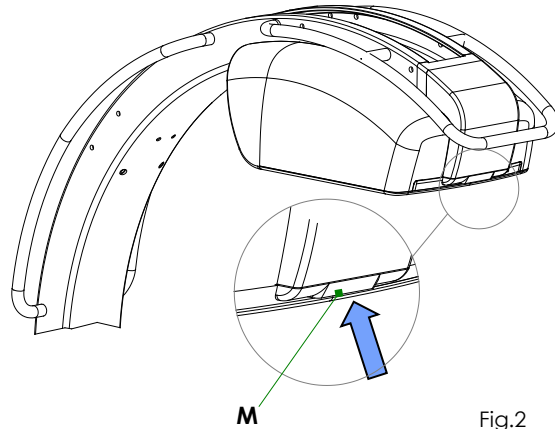

- Open the drawer containing the grid **(A)** as indicated in Fig. 3
- Unlock the grid, springing the clip **(B)** as shown in fig. 3
- **Extract the grid (G):** put the grid in an appropriate place.

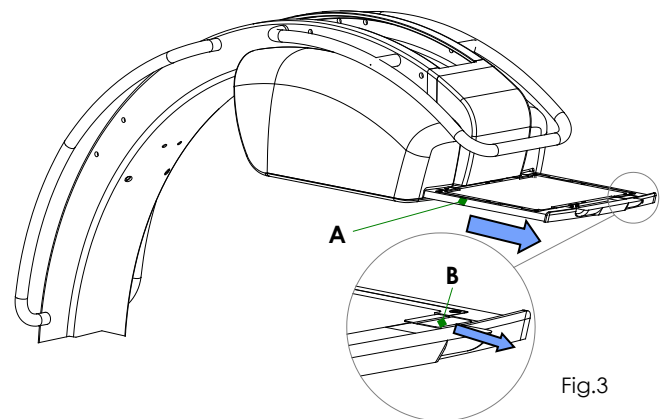

- **Insert the grid (G):** there are some "keys" in the frame of the grid support and drawer that ensure the grid can only be inserted in the correct direction (see Fig. 4).

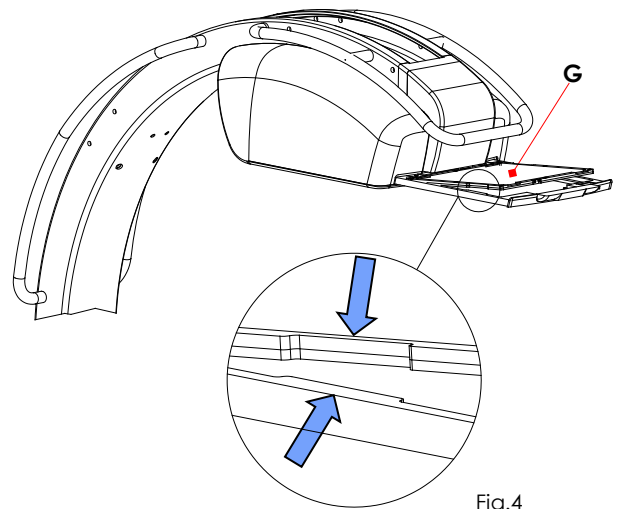

- Close the drawer **(A)**.



Note: it is responsibility of the physician to decide if use or not the grid.

1.4 VIDEO PROCESSOR SETUP

1.4.1 INTRODUCTION

The **Advanced User** can configure the system to suit the specific installation needs. The configuration is performed on main monitor by specific setup pages, where only the required parameters are enabled.

The configuration procedure is described below, with details of the parameters that can be set.

Setup	Settings	Ref. (paragraph)
General Settings	- Station Description - Technical Configuration - Image Option and Unit of Measure	Installation: par. 1.4.2
Unit Configuration	System date	Installation: par. 1.4.3
Exam Setup	Exam list organization	Installation: par. 1.4.4/1.4.5
Fixed String Setup	Composition and organisation of the fixed strings	Installation: par. 1.4.6
User Account Setup	Composition and organisation of Users	Installation: par. 1.4.7
Firewall Info	Info about firewall status and possible warnings or alarms.	Installation: par. 1.4.8

Press the USER icon in the top left-hand corner of the monitor to open the menu that allows to access the system SETUP.

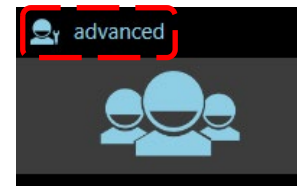

Select the **Setup** option to access the SETUP menu:

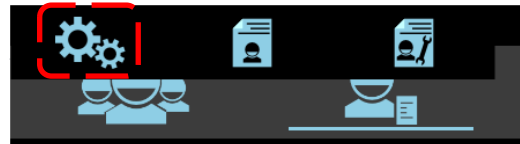

List of SETUP menus:

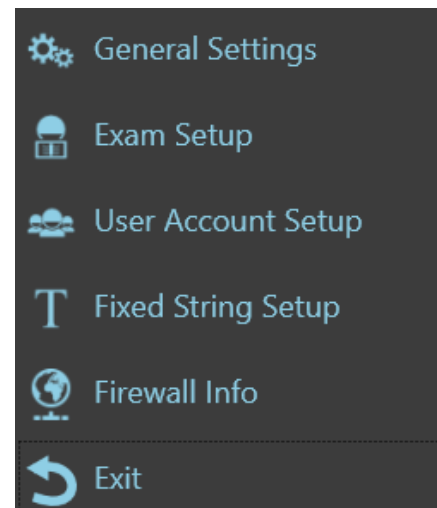

1.4.1.1 LOGIN

- When the LOG-IN page appears, log in as: **Advanced**, by entering the default technical password: **12345678**.

Note: it is recommended to update the Advanced default password at the installation.

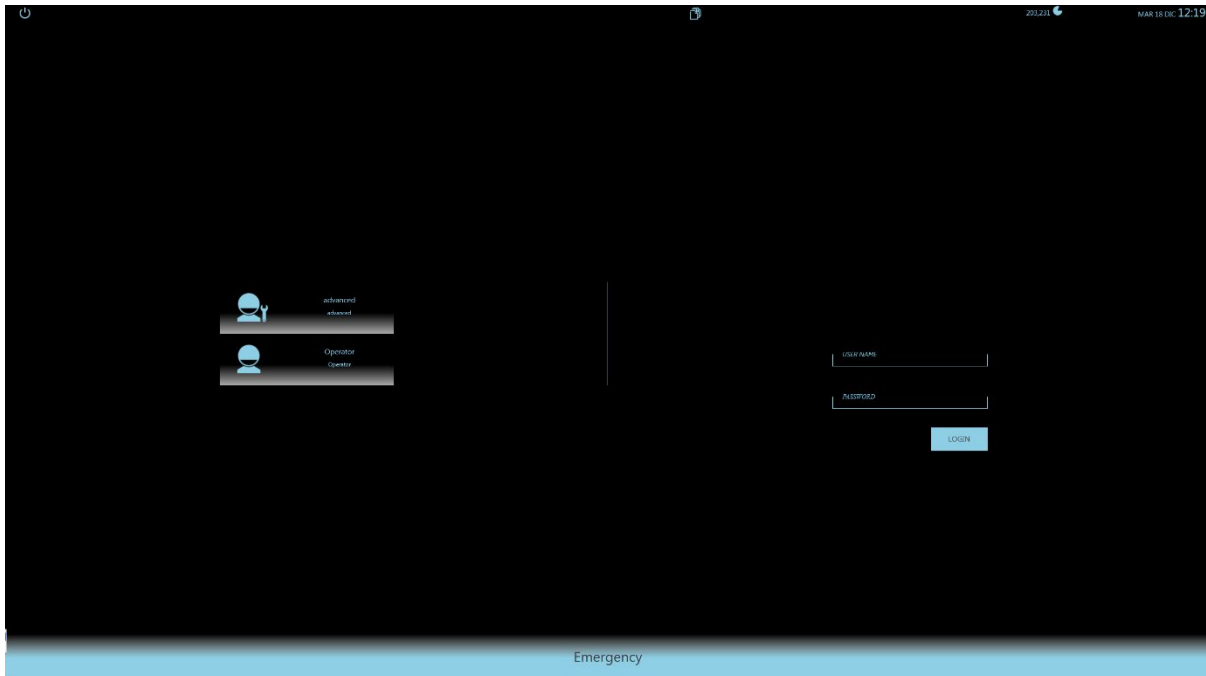

1.4.2 GENERAL SETTINGS

➤ **STATION DESCRIPTION:**

STATION DESCRIPTION			
INSTITUTION NAME	HOSPITAL	MANUFACTURER	
STATION NAME	C ARM	MODEL	

Option	Meaning / Settings	Notes
INSTITUTION NAME	Enter the name of the hospital/clinic where the EM equipment is installed.	This name does not appear on the screen but is needed for the DICOM services.
MANUFACTURER	The name of the manufacturer of the EM equipment.	This name does not appear on the screen but is needed for the DICOM services.
STATION NAME	Name given to the EM equipment.	This name does not appear on the screen but is needed for the DICOM services.
MODEL	EM equipment model.	This name does not appear on the screen but is needed for the DICOM services.

➤ **TECHNICAL CONFIGURATION:**

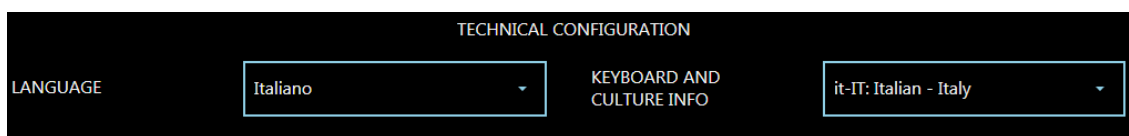

Option	Meaning	Settings	Notes
LANGUAGE	Used to select the interface language.	Options: Italian English French Spanish German	The technical installation and maintenance menus are only provided in Italian or English.
KEYBOARD AND CULTURE INFO	Used to select the geographical area where the EM equipment is installed.	Select one of the areas given.	This setting determines the date format, the decimals format and the virtual keyboard layout.

➤ **IMAGE OPTION AND UNIT OF MEASURE:**

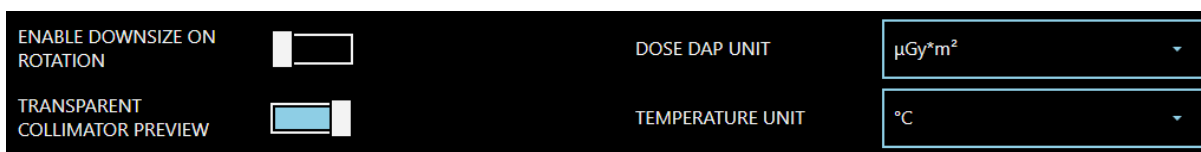

Option	Meaning	Settings	Notes
ENABLE DOWNSIZE ON ROTATION	<p>DISABLED: when rotated, the image dimensions are not changed. Depending on the angle of rotation, part of the corners of the image will be outside the screen (not displayed).</p> <p>ENABLED: when rotated, the image dimensions are reduced to allow you to see the full image.</p>	Enable or disable this function to suit the required mode.	
TRANSPARENT COLLIMATOR PREVIEW	<p>DISABLED: When a virtual collimation is performed on the LIH, it is shown in black, getting dark the part of image that lies outside the collimation.</p> <p>ENABLED: When a virtual collimation is performed on the LIH, it is shown transparent, letting glimpse the part of image that lies outside the collimation.</p>	Enable or disable this function to suit the required mode.	
DOSE DAP UNIT	Set dose unit of measure.	Choose $\mu\text{Gy}\cdot\text{m}^2$ or $\text{mGy}\cdot\text{cm}^2$.	
TEMPERATURE UNIT	Set the unit of measure for the temperature of the x-ray monoblock.	Choose °C or °F.	

1.4.3 UNIT CONFIGURATION

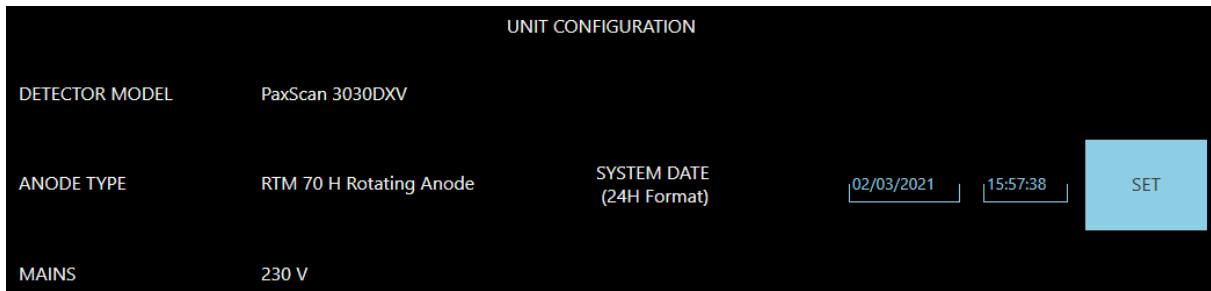

➤ UNIT CONFIGURATION

Option	Meaning	Settings	Notes
DETECTOR MODEL	Indication of the FPD model present on the EM equipment.		
ANODE TYPE	Indicates the anode type present on the equipment.		
MAINS	Indication of the mains power supply: 120 V or 230 V .		
SYSTEM DATE	The Advanced user has the possibility to restore date and time settings.	Set current date and time.	24 HOURS format

1.4.4 ANATOMICAL EXAM SETUP

The EM equipment has exams already defined by the manufacturer, linked to the different device applications.

At the installation phase, the exam parameters can be modified by the **Advanced** user, according to the user requirements.

Like this, whenever the exam is selected, the related parameters will be automatically set.

The exams are shown on the Control Panel in the order they have been set inside the Exam Setup. The screen shows 5 exams at a time; use the respective arrows, circled in red in the image below, to browse through the exam list, scrolling thus to the next or previous 5 exams.

Note: If the operator needs to change some of the exam parameters, after the installation, it is required to login as **Advanced** user.

The following images show an example of how an exam is set:

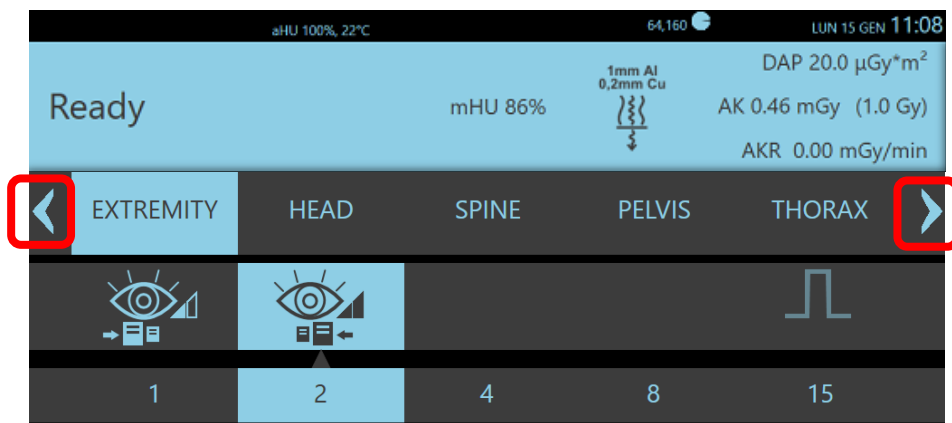

Use the indicated arrows to browse through the exam list, scrolling thus to the next or previous group.

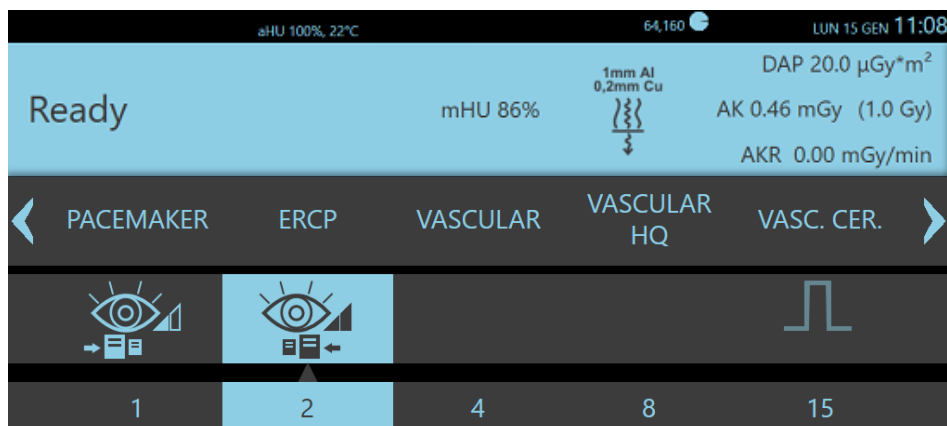

1.4.4.1 PROGRAMMABLE PARAMETERS

Select the exam to set from the drop-down list. The following parameters can be set for each exam:

GENERAL:

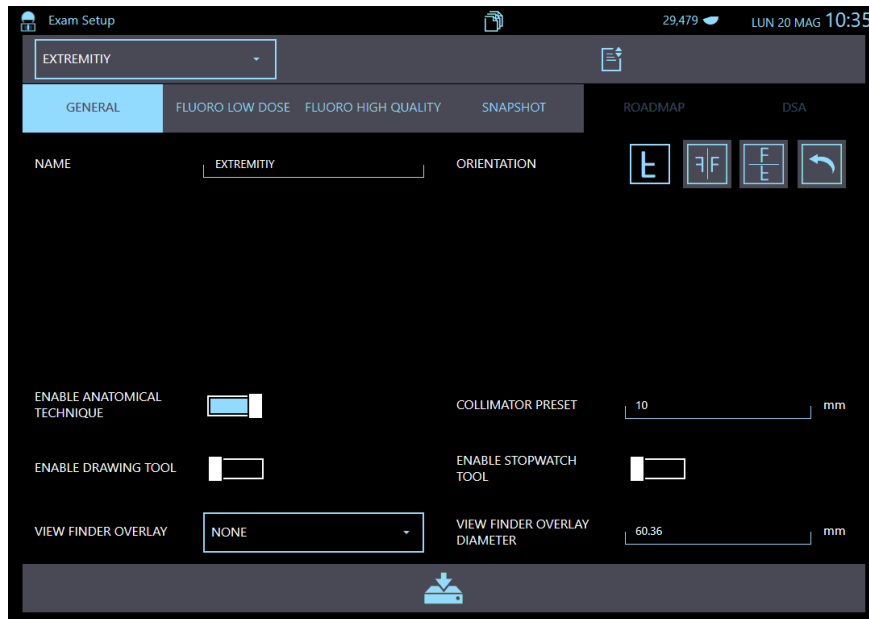

Option	Meaning	Settings	Notes
NAME	Exam name	Max 30 characters	
ORIENTATION	Orientation of the image (inverted and/or rotated)	Horizontal flip Vertical flip Image rotation ($\pm 90^\circ$)	Orientation set when you open an exam.
ENABLE ANATOMICAL TECHNIQUE	This function allows to enable the exam, making it available from the Control Panel.	Yes / No	If the exam is not enabled, it will not be shown on the Control Panel.
COLLIMATOR PRESET	This function allows to set an opening default value for the collimator square iris. It will be possible to use this value, during an exam, by touching the relevant key on the Control Panel (see Paragraph 1.2.1.1, Part 1 of this Manual).	Enter the required value, range: 10 - 300 mm . Entering 0 , the function is disabled and the relevant button will not be shown on the Control Panel.	The function involves only the collimator square-field.
ENABLE DRAWING TOOL	It enables or disables the Live Drawing function on Control Panel and Live area of the monitor (see Paragraph 3.1.2, Part 2 of this Manual).	Yes / No	If the function is disabled, the relevant button will not be shown.
ENABLE STOPWATCH TOOL	It enables or disables the Stopwatch function on Control Panel and Live area of the monitor. See Paragraph 2.3.11, Part 2 of this Manual.	Yes / No	If the function is disabled, the relevant button will not be shown.
VIEW FINDER OVERLAY	It is possible to activate a viewfinder (Crosshairs or Circle shaped) that will be shown on the image central part.	None or Crosshairs or Circle .	None: the function is disabled and the relevant button will not be shown. See Paragraph 2.3.12, Part 2 of this Manual.
VIEW FINDER OVERLAY DIAMETER	Set overlay diameter (in mm).	30 ÷ 80 mm	

LOW DOSE FLUOROSCOPY:

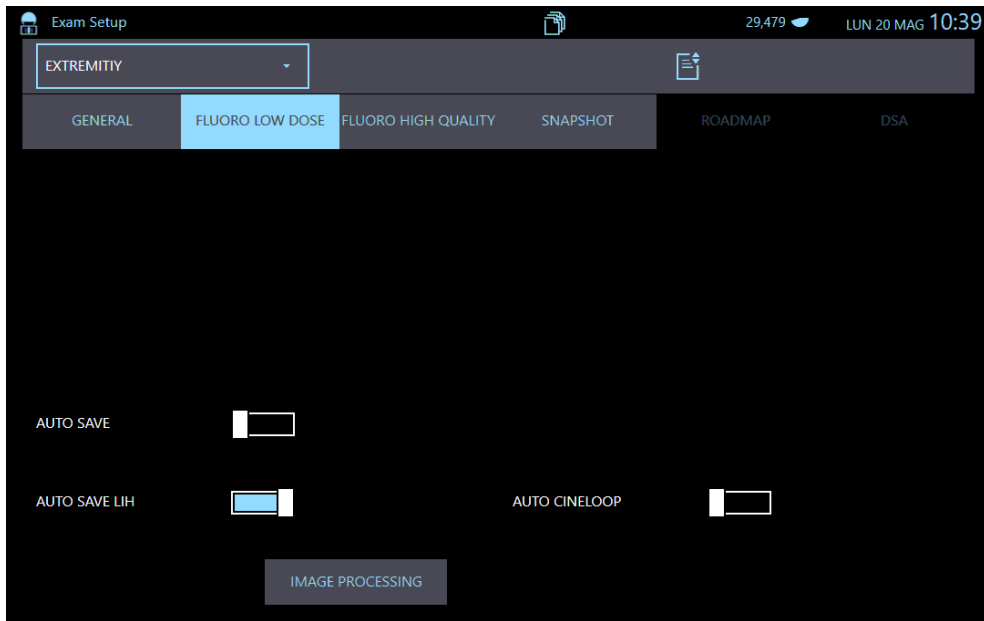

LOW DOSE FLUOROSCOPY parameters

Option	Meaning	Settings	Notes
AUTO SAVE	Automatic saving to hard disk of all the image acquired.	Normally NOT enabled.	As an alternative to AUTO SAVE LIH
AUTO SAVE LIH	Automatic saving to hard disk of the last image hold (LIH).	Normally enabled.	As an alternative to AUTO SAVE
AUTO CINELOOP	Automatic activation of the cine loop after acquiring a run of images	Yes / No	This function is only active if a run has been saved.

HIGH QUALITY FLUOROSCOPY:

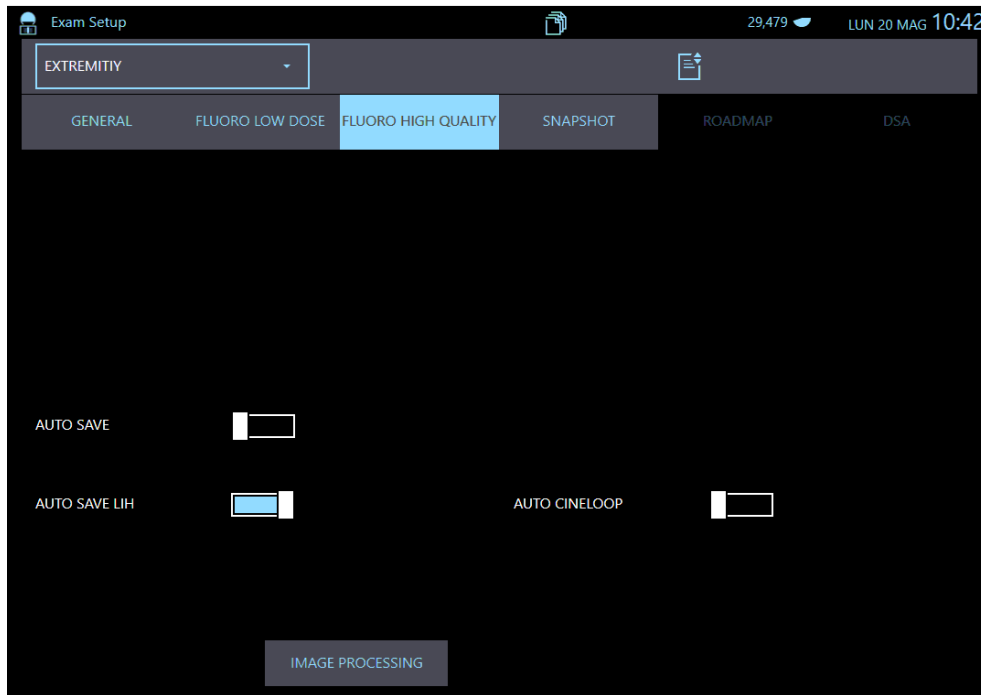

HIGH QUALITY FLUOROSCOPY parameters:

Option	Meaning	Settings	Notes
AUTO SAVE LIH	Automatic saving to hard disk of the last image hold (LIH).	Normally NOT enabled.	As an alternative to AUTO SAVE
AUTO SAVE	Automatic saving to hard disk of all the image acquired.	Normally enabled.	As an alternative to AUTO SAVE LIH
AUTO CINELOOP	Automatic saving of the cine loop after acquiring a run of images	Yes / No	This function is only active if the images in the run have been saved to hard disk

ROADMAP:

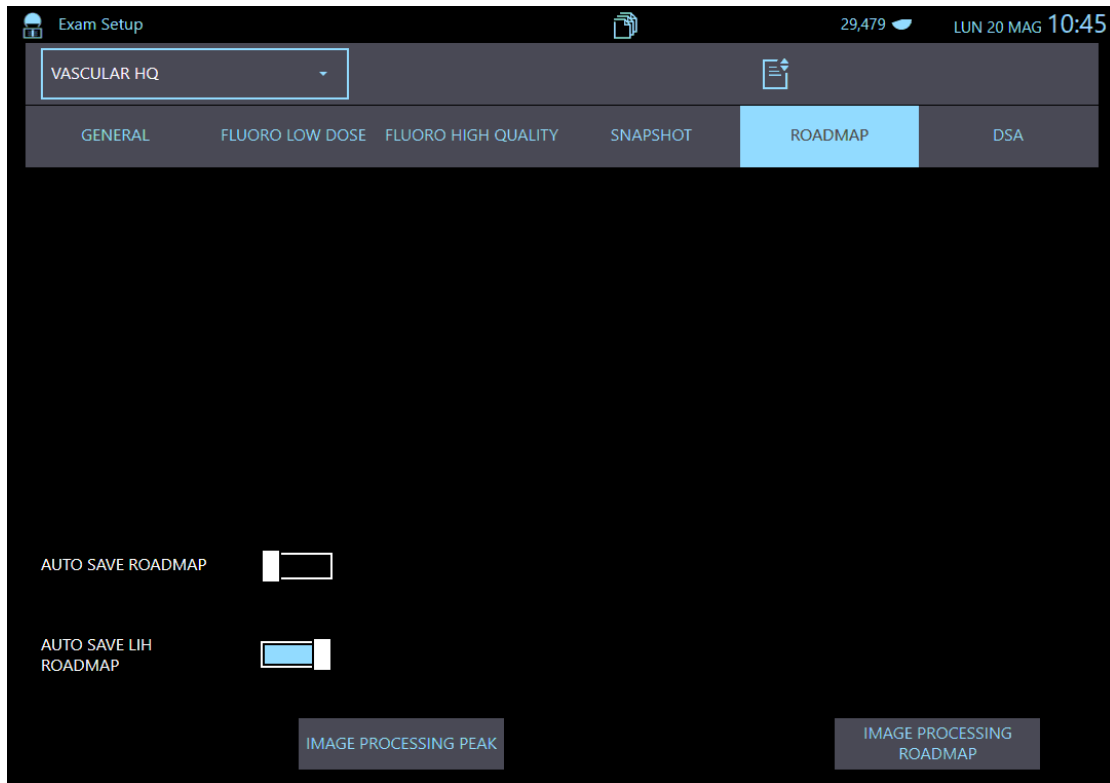

ROADMAP Parameters:

Option	Meaning	Settings	Notes
AUTO SAVE ROADMAP	If enabled, all the images in the run will be saved to hard disk.	Yes / No	As an alternative to AUTO SAVE LIH ROADMAP
AUTO SAVE LIH ROADMAP	If enabled, only the Last Image Hold (LIH) image is saved to hard disk.	Yes / No	As an alternative to AUTO SAVE ROADMAP

DSA Fluoroscopy:

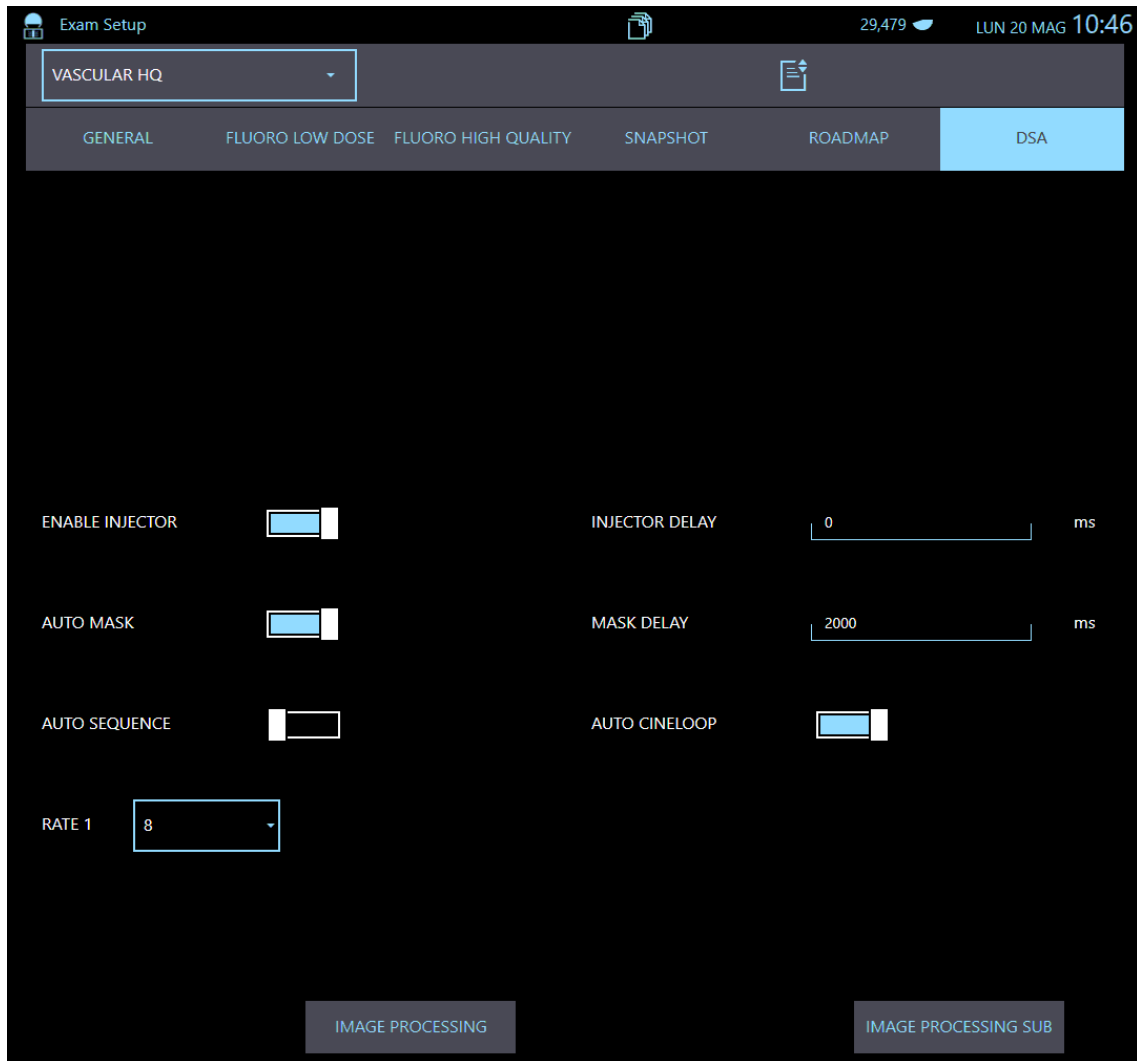

You can program some specific parameters for a DSA exam during installation. These are automatically set once you open DSA acquisition mode:

- **Phase duration**, defined by duration and pulse rate; the exam can be set to have one or two acquisition phases, each one with its own acquisition rate. The exam ends 30 seconds after the x-ray emission started or when the x-ray command is released.
- **Number of acquisition phases**: the exam can be set to last max 40 seconds (up to 10 seconds of anticipation time for the injector, if needed, and up to 30 seconds of x-ray emission).
- **Automatic injector control**: to anticipate/delay the moment that the injector starts with respect to the start of X-ray emission.
- **Mask image uptake delay** from the start of X-ray exposure (0 – 25 seconds).

During the exam, the operator can adjust the default parameters directly from the Control Panel to suit actual needs.

DSA Fluoroscopy Parameters

Option	Meaning	Settings	Notes
ENABLE INJECTOR	When this function is enabled, the operator can use an injector controlled by the system.	Yes / No	If enabled, when the exam is opened, the injector icon will be shown.
INJECTOR DELAY	Delay (positive number) or anticipation (negative number), indicated in ms, for the start of the injector with respect to the start of X-ray exposure.	From -10 to +25 seconds.	Available if ENABLE INJECTOR option is enabled.
AUTO MASK	To enable the automatic mask uptake function, at the moment defined by MASK DELAY option.	Yes / No	
MASK DELAY	Delay, indicated in ms, between the X-ray exposure start and mask image acquisition.		Once the mask image has been taken up, the system shows the image in subtraction mode.
AUTO SEQUENCE	This function divides the DSA exam into two phases: the operator can set the acquisition rate and duration of each phase.		
RATE 1 RATE 2	Acquisition rate of each phase.	Choose between shown values: 1 – 2 – 4 – 8 – 15	The operator can change the rate values on opening the exam.
SPAN RATE 1	RATE 1 phase duration, in ms		
AUTO CINE LOOP	Automatic activation of the cine loop after acquisition of a run of images	Yes / No	This function is only active if the images in the run have been saved to hard disk

1.4.4.2 IMAGE PROCESSING

IMAGE PROCESSING parameters can be set for each exam in each acquisition mode.

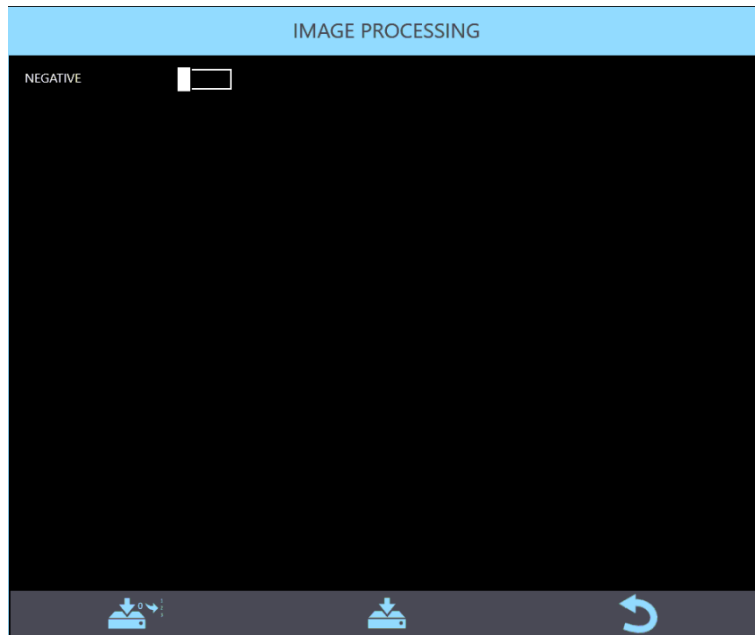

IMAGE PROCESSING parameters:

Option	Meaning	Settings	Notes
NEGATIVE	"Negative" display of the grey scale	Yes / No	Typically enabled for images acquired in digital radiography mode, only.

1.4.5 EXAMS MANAGEMENT

The EM equipment is provided with a set of already configured exams.

Advanced user could change the order of the exam in the relevant list (see Paragraph 1.4.5.1 below).

1.4.5.1 ORGANIZE THE EXAM LIST

The EM equipment stores all the exams created (enabled or not), in a same list. Only those enabled will be shown in the list of the **Control Panel**.

Exams, on the Control Panel, are presented in the same order set here.

Use the **ANATOMIC TECHNIQUE ORDER** (here below) to change an exam position: just select it and, using relevant tips, move it to the required position.

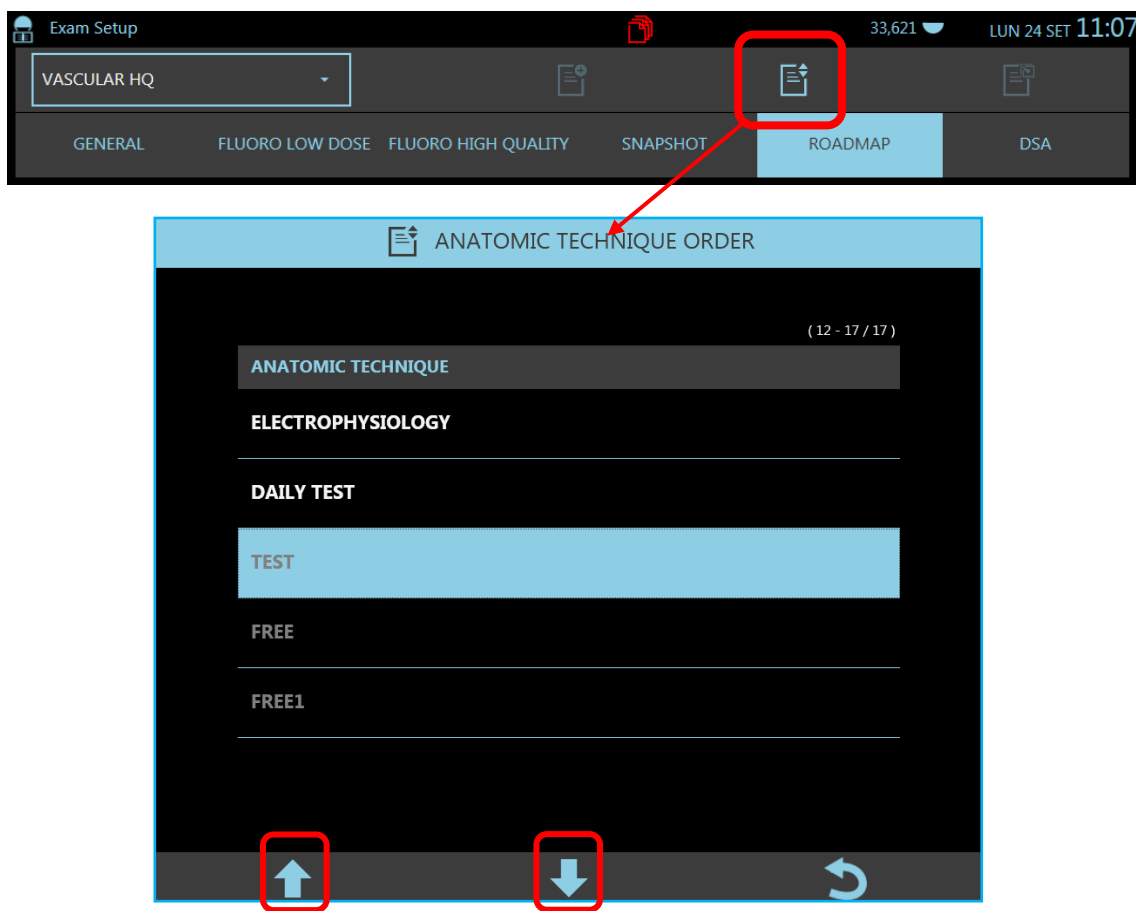

Note: enabled exams are presented in white, while those not enabled in grey.

1.4.6 FIXED STRING SETUP

It is possible to preset a series of often used texts ("fixed strings"), which can be easily retrieved by the operator during the post-processing operations so as to place them on acquired images.

To create and update this list of strings, use the **Fixed Strings Setup menu**:



Any number of strings can be added (max length 20 characters).

The commands are:



to add a new string,



to delete the selected string from the list,



to move the selected string up/down within the list.

- Select the **New String** command to open the user configuration page:

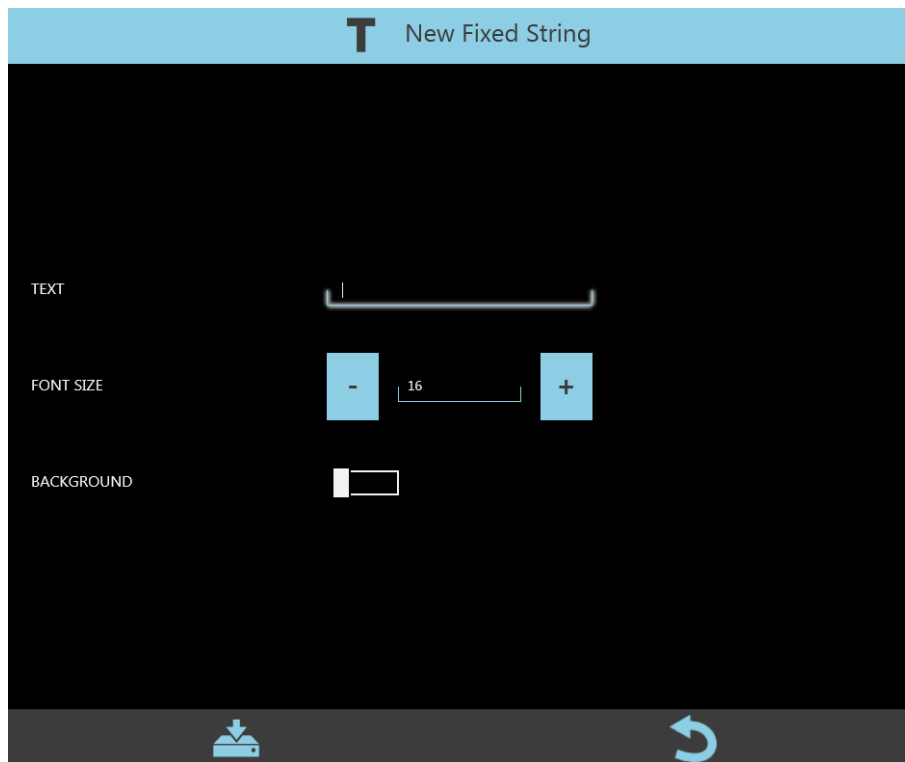

- Here you can set:
 - **Text:** contents of the string (max 20 characters);
 - **Font Size:** size of the string;
 - **Background:** a black box is added as a background for the string.
- Use the command to complete the creation of the new string and add it to the list of existing strings.



1.4.7 USER ACCOUNT SETUP

The **User Account Setup** menu lets you manage the creation, enabling/disabling and deletion of system users.

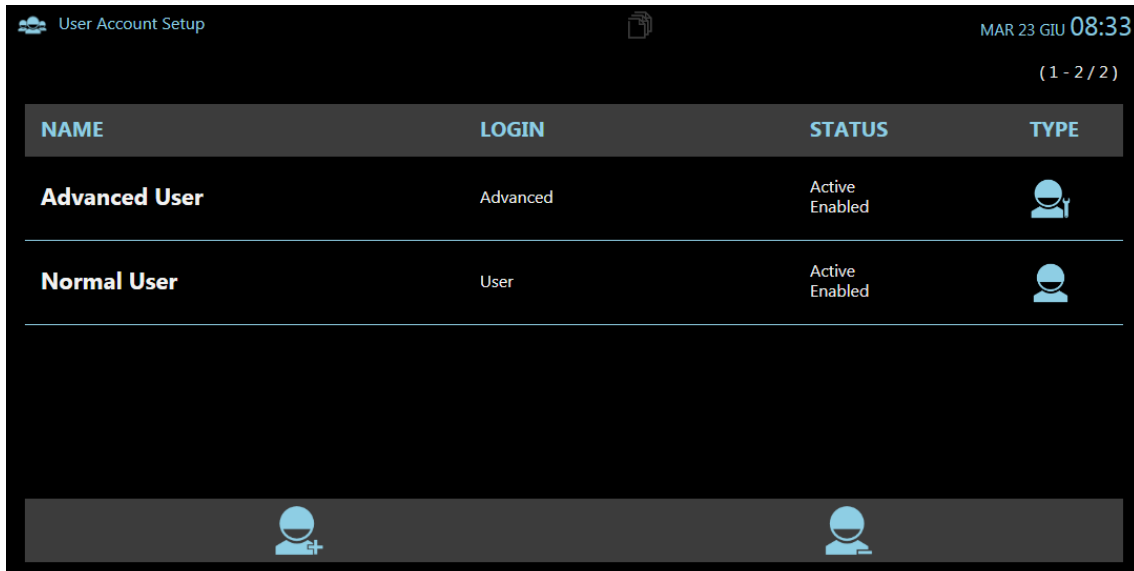

There are three user levels:

- Administrator (user pre-set in factory)
- Advanced (set during installation)
- Operator

The privileges for each user type are:

- **Administrator:** full access to the EM equipment
- **Advanced:** routine operations and access to the following SETUP pages:
 - General Settings setup,
 - Exam setup,
 - Fixed String setup
 - User Account setup.

Note: some of the parameters should not be available to **Advanced** user.

- **Operator:** routine operations only.

Each user has a unique password.

The system is meant to have only one **Administrator** user, with a unique password (pre-set and that never expires).

- Select the command to open the user configuration page:



- Here you can set:

- **Login:** name used to identify the user accessing the equipment (user name);
- **Name:** typically, the user's full first name and surname;
- **Password** and **Repeat Password:** password to be entered in order to access the equipment (at least 8 characters);
- **Level: Normal / Advanced** (a new Administrator cannot be created).
- **Read Badge** function: This function allows to link a magnetic personal badge, to speed up the Login procedure. To enable this function, just place the badge near the reader and press the **Read Badge** key. A message appears to confirm the badge has been correctly linked to its user.



- Press the  command to complete the user entry and save the data.

Each password is valid for 90 days, after which time the user must enter a new one. 15 days before a password expires, a warning message appears whenever the user logs in, indicating that the password will expire shortly.

If a user does not use the equipment for 6 months, the corresponding user account is automatically disabled and will not be displayed in the LOGIN list.

1.4.8 FIREWALL INFO

This menu is divided in two pages:

- **Information Log** page,
- **Warning /Alarm Log** page.

The first page provides information about **Windows Defender Firewall** status and possible updates. Logs are defined by Date and Time, Level and a brief Description.

Datetime	Level	Description
18/06/2019 12:49:50	Information	A rule has been added to the Windows Defender Firewall exception list.
18/06/2019 12:49:50	Information	A rule has been added to the Windows Defender Firewall exception list.
18/06/2019 12:49:50	Information	A rule has been deleted in the Windows Defender Firewall exception list.
18/06/2019 12:49:50	Information	A rule has been deleted in the Windows Defender Firewall exception list.

The second one provides information about possible external attacks to the system (security breach). Warnings or alarms are defined by Date and Time, Level and a brief Description.

Datetime	Level	Description
----------	-------	-------------

1.5 PATIENT DOSE INFORMATION

These are typical dose values (**Air-Kerma rate** or **Air-Kerma**) for the exams as they are set up by the manufacturer; they remain valid with the factory exam settings (see the following tables).

1.5.1 MEASURING THE DOSE

The measurement of the **dose administered to the patient** has been carried out in compliance with the provisions of the standard **EN 60601-2-54**.

EXTREMITY exam has been carried out using a **10 cm-thick PMMA phantom**.

In this exam, the **Anti-scattering grid** is **not** required and the deterministic effects threshold value is set at **1 Gy**.

For all the other exams, **20 cm-thick PMMA phantom** in order to simulate an exam that involves an average patient.

In these exams the **Anti-scattering grid** is required and the deterministic effects threshold value is set at **2 Gy**.

Exposure parameters are determined from the **Automatic Dose Control (ADC)**.

Using the same **20 cm-thick PMMA phantom**, it has been measured the dose value at **max kV value (120 kV)**, to simulate an exam that involves an overweight patient.

In the tables below, are reported:

- The collimator filter set for the exam.
- The acquisition rate used for the test
(Note: *the patient dose value is proportional to the acquisition rate*).
- For **Fluoroscopy** exposures: the patient dose value, expressed in **mGy/min (Air-Kerma rate)** and the indication of the minutes of exposures required to reach the threshold for deterministic effects (**1** or **2Gy**).
- For **Digital Radiography** exposures: the patient dose value, expressed in **mGy/image (Air-Kerma)** and the indication of the numbers of exposures required to reach the threshold for deterministic effects (**1** or **2Gy**).

EXTREMITY							
Collimator filter: 1mm Al + 0.2 mm Cu, NO GRID							
@15 fps	10cm-PMMA PHANTOM				@ 120kV		
	kV	mA AVERAGE	Air-Kerma rate mGy/min	Minutes of exposure (1Gy) ⁽¹⁾	mA AVERAGE	Air-Kerma rate mGy/min	Minutes of exposure (1Gy) ⁽¹⁾
FLUORO LD	50	0,79	0,28	3571	3,1	17,23	58
FLUORO HQ	50	1,44	0,45	2222	7,5	42,11	23,7
	kV	mAs	Air-Kerma mGy	Number of exposures (1Gy) ⁽²⁾	mAs	Air-Kerma mGy	Number of exposures (1Gy) ⁽²⁾
SNAPSHOT	50	6,3	0,04	25000	4	0,37	2702

HEAD							
Collimator filter: 1mm Al + 0.1 mm Cu							
@15fps	20cm-PMMA PHANTOM				@ 120kV		
	kV	mA AVERAGE	Air-Kerma rate mGy/min	Minutes of exposure (2Gy) ⁽¹⁾	mA AVERAGE	Air-Kerma rate mGy/min	Minutes of exposure (2Gy) ⁽¹⁾
FLUORO LD	62	3,3	3,81	524,9	3,1	21,93	91,2
FLUORO HQ	63	8,5	10,29	194,3	7.5	53,59	37,3
	kV	mAs	Air-Kerma mGy	Number of exposures (2Gy) ⁽²⁾	mAs	Air-Kerma mGy	Number of exposures (2Gy) ⁽²⁾
SNAPSHOT	63	20	0,38	5263	2,0	0,23	8695

SPINE							
Collimator filter: 1mm Al + 0.1 mm Cu							
@15fps	20cm-PMMA PHANTOM				@ 120kV		
	kV	mA AVERAGE	Air-Kerma rate mGy/min	Minutes of exposure (2Gy) ⁽¹⁾	mA AVERAGE	Air-Kerma rate mGy/min	Minutes of exposure (2Gy) ⁽¹⁾
FLUORO LD	62	3,3	3,81	524,9	3,1	21,93	91,2
FLUORO HQ	63	8,5	10,29	194,3	7.5	53,59	37,3
	kV	mAs	Air-Kerma mGy	Number of exposures (2Gy) ⁽²⁾	mAs	Air-Kerma mGy	Number of exposures (2Gy) ⁽²⁾
SNAPSHOT	63	20	0,38	5263	2,0	0,23	8695

PELVIS							
Collimator filter: 1mm Al + 0.1 mm Cu							
@15fps	20cm-PMMA PHANTOM				@ 120kV		
	kV	mA AVERAGE	Air-Kerma rate mGy/min	Minutes of exposure (2Gy) ⁽¹⁾	mA AVERAGE	Air-Kerma rate mGy/min	Minutes of exposure (2Gy) ⁽¹⁾
FLUORO LD	62	3,3	3,81	524,9	3,1	21,93	91,2
FLUORO HQ	63	8,5	10,29	194,3	7.5	53,59	37,3
	kV	mAs	Air-Kerma mGy	Number of exposures (2Gy) ⁽²⁾	mAs	Air-Kerma mGy	Number of exposures (2Gy) ⁽²⁾
SNAPSHOT	63	20	0,38	5263	2,0	0,23	8695

THORAX							
Collimator filter: 1mm Al + 0.1 mm Cu							
@15fps	20cm-PMMA PHANTOM				@ 120kV		
	kV	mA AVERAGE	Air-Kerma rate mGy/min	Minutes of exposure (2Gy) ⁽¹⁾	mA AVERAGE	Air-Kerma rate mGy/min	Minutes of exposure (2Gy) ⁽¹⁾
FLUORO LD	62	3,3	3,81	524,9	3,1	21,93	91,2
FLUORO HQ	63	8,5	10,29	194,3	7.5	53,59	37,3
	kV	mAs	Air-Kerma mGy	Number of exposures (2Gy) ⁽²⁾	mAs	Air-Kerma mGy	Number of exposures (2Gy) ⁽²⁾
SNAPSHOT	63	20	0,38	5263	2,0	0,23	8695

PACEMAKER							
Collimator filter: 1mm Al + 0.1 mm Cu							
@15 fps	20cm-PMMA PHANTOM				@ 120kV		
	kV	mA AVERAGE	Air-Kerma rate mGy/min	Minutes of exposure (2Gy) ⁽¹⁾	mA AVERAGE	Air-Kerma rate mGy/min	Minutes of exposure (2Gy) ⁽¹⁾
FLUORO LD	76	4,9	9,77	204,7	3,1	21,93	91,2
FLUORO HQ	68	11	16,59	120,5	7,5	53,59	37,3
	kV	mAs	Air-Kerma mGy	Number of exposures (2Gy) ⁽²⁾	mAs	Air-Kerma mGy	Number of exposures (2Gy) ⁽²⁾
SNAPSHOT	65	12,5	0,31	6451	10	1,20	1666

ERCp							
Collimator filter: 1mm Al + 0.1 mm Cu							
@15fps	20cm-PMMA PHANTOM				@ 120kV		
	kV	mA AVERAGE	Air-Kerma rate mGy/min	Minutes of exposure (2Gy) ⁽¹⁾	mA AVERAGE	Air-Kerma rate mGy/min	Minutes of exposure (2Gy) ⁽¹⁾
FLUORO LD	62	3,3	3,81	524,9	3,1	21,93	91,2
FLUORO HQ	63	8,5	10,29	194,3	7.5	53,59	37,3
	kV	mAs	Air-Kerma mGy	Number of exposures (2Gy) ⁽²⁾	mAs	Air-Kerma mGy	Number of exposures (2Gy) ⁽²⁾
SNAPSHOT	63	20	0,38	5263	2,0	0,23	8695

UROLOGY							
Collimator filter: 1mm Al + 0.1 mm Cu							
@15fps	20cm-PMMA PHANTOM				@ 120kV		
	kV	mA AVERAGE	Air-Kerma rate mGy/min	Minutes of exposure (2Gy) ⁽¹⁾	mA AVERAGE	Air-Kerma rate mGy/min	Minutes of exposure (2Gy) ⁽¹⁾
FLUORO LD	62	3,3	3,81	524,9	3,1	21,93	91,2
FLUORO HQ	63	8,5	10,29	194,3	7,5	53,59	37,3
	kV	mAs	Air-Kerma mGy	Number of exposures (2Gy) ⁽²⁾	mAs	Air-Kerma mGy	Number of exposures (2Gy) ⁽²⁾
SNAPSHOT	63	20	0,38	5263	2,0	0,23	8695

PAIN MANAGEMENT							
Collimator filter: 1mm Al + 0.1 mm Cu							
@15fps	20cm-PMMA PHANTOM				@ 120kV		
	kV	mA AVERAGE	Air-Kerma rate mGy/min	Minutes of exposure (2Gy) ⁽¹⁾	mA AVERAGE	Air-Kerma rate mGy/min	Minutes of exposure (2Gy) ⁽¹⁾
FLUORO LD	62	3,3	3,81	524,9	3,1	21,93	91,2
FLUORO HQ	63	8,5	10,29	194,3	7,5	53,59	37,3
	kV	mAs	Air-Kerma mGy	Number of exposures (2Gy) ⁽²⁾	mAs	Air-Kerma mGy	Number of exposures (2Gy) ⁽²⁾
SNAPSHOT	63	20	0,38	5263	2,0	0,23	8695

VASCULAR							
Collimator filter: 1mm Al + 0.1 mm Cu							
@15 fps	20cm-PMMA PHANTOM				@ 120kV		
	kV	mA AVERAGE	Air-Kerma rate mGy/min	Minutes of exposure (2Gy) ⁽¹⁾	mA AVERAGE	Air-Kerma rate mGy/min	Minutes of exposure (2Gy) ⁽¹⁾
FLUORO LD	67	4,4	6,27	318,9	3,1	21,93	91,2
FLUORO HQ	63	8,5	10,29	194,3	7,5	53,59	37,3
ROADMAP	71	5,0	8,28	241,5	3,1	21,93	91,2
DSA @ 8 imm/s	68	11,0	16,59	120,5	4,0	53,59	37,3
	kV	mAs	Air-Kerma mGy	Number of exposures (2Gy) ⁽²⁾	mAs	Air-Kerma mGy	Number of exposures (2Gy) ⁽²⁾
SNAPSHOT	64	20	0,43	4651	10	1,20	1666

VASCULAR HQ							
Collimator filter: 1mm Al + 0.1 mm Cu							
@15 fps	20cm-PMMA PHANTOM				@ 120kV		
	kV	mA AVERAGE	Air-Kerma rate mGy/min	Minutes of exposure (2Gy) ⁽¹⁾	mA AVERAGE	Air-Kerma rate mGy/min	Minutes of exposure (2Gy) ⁽¹⁾
FLUORO LD	71	5	8,28	241,5	3,1	21,93	91,2
FLUORO HQ	68	11	16,59	120,5	7,5	53,59	37,3
ROADMAP	71	5	8,28	241,5	3,1	21,93	91,2
DSA @ 8 imm/s	68	11	16,59	120,5	7,5	53,59	37,3
	kV	mAs	Air-Kerma mGy	Number of exposures (2Gy) ⁽²⁾	mAs	Air-Kerma mGy	Number of exposures (2Gy) ⁽²⁾
SNAPSHOT	71	10	0,28	7142	10	1,20	1666

VASCULAR CEREBRAL							
Collimator filter: 1mm Al + 0.1 mm Cu							
@15 fps	20cm-PMMA PHANTOM				@ 120kV		
	kV	mA AVERAGE	Air-Kerma rate mGy/min	Minutes of exposure (2Gy) ⁽¹⁾	mA AVERAGE	Air-Kerma rate mGy/min	Minutes of exposure (2Gy) ⁽¹⁾
FLUORO LD	67	4,4	6,27	318,9	3,1	21,93	91,2
FLUORO HQ	63	8,5	10,29	194,3	7,5	53,59	37,3
ROADMAP	71	5,0	8,28	241,5	3,1	21,93	91,2
DSA @ 8 imm/s	68	11,0	16,59	120,5	4,0	53,59	37,3
	kV	mAs	Air-Kerma mGy	Number of exposures (2Gy) ⁽²⁾	mAs	Air-Kerma mGy	Number of exposures (2Gy) ⁽²⁾
SNAPSHOT	64	20	0,43	4651	10	1,20	1666

ELECTROPHYSIOLOGY							
Collimator filter: 1mm Al + 0.1 mm Cu							
@15 fps	20cm-PMMA PHANTOM				@ 120kV		
	kV	mA AVERAGE	Air-Kerma rate mGy/min	Minutes of exposure (2Gy) ⁽¹⁾	mA AVERAGE	Air-Kerma rate mGy/min	Minutes of exposure (2Gy) ⁽¹⁾
FLUORO LD	76	4,9	9,77	204,7	3,1	21,93	91,2
FLUORO HQ	68	11	16,59	120,5	7,5	53,59	37,3
	kV	mAs	Air-Kerma mGy	Number of exposures (2Gy) ⁽²⁾	mAs	Air-Kerma mGy	Number of exposures (2Gy) ⁽²⁾
SNAPSHOT	65	12,5	0,31	6451	10	1,20	1666

1.6 DISPERSED RADIATION IN OCCUPIED AREAS

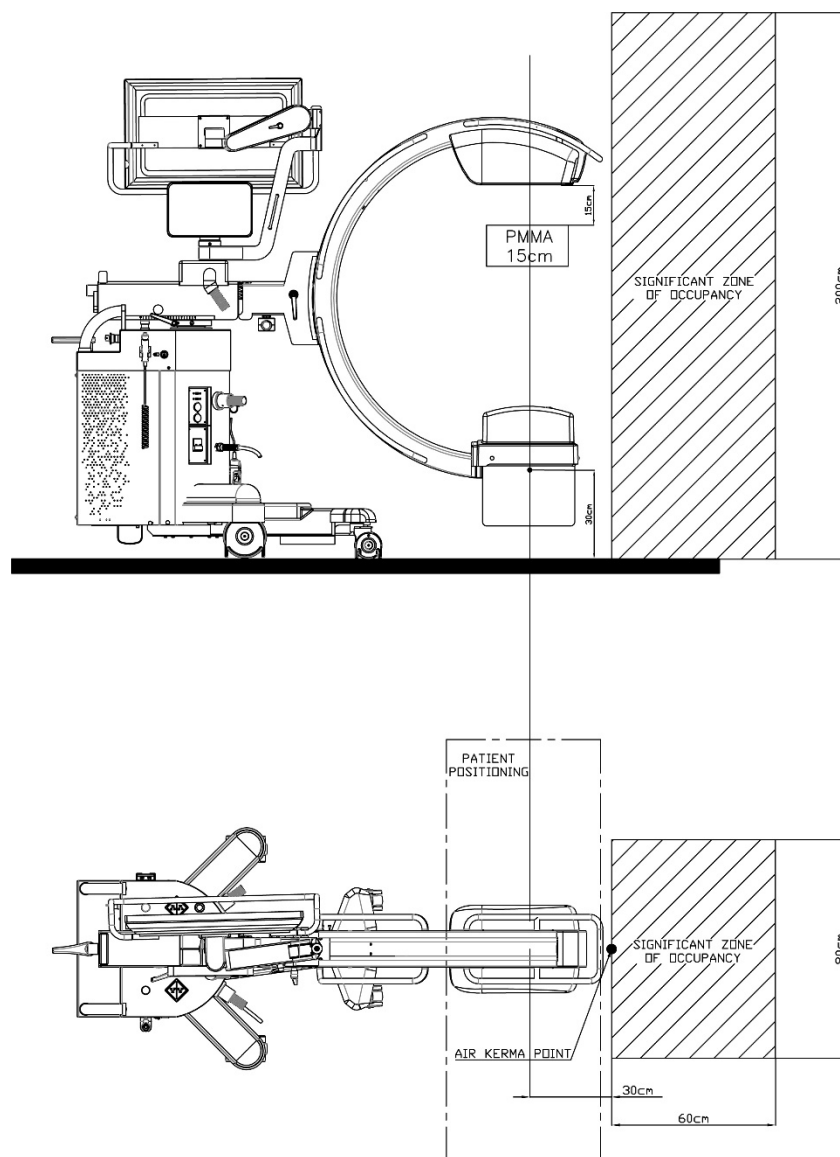

Measurement conditions (in compliance with EN60601-2-54 standard):

- Exposure: **ERCP fluoroscopy HQ - 120kV / 3,1mA_{avg} / 15 fps**
- Additional beam filtration: **No additional filter**
- Measuring instrument: **INOVISION 35050**

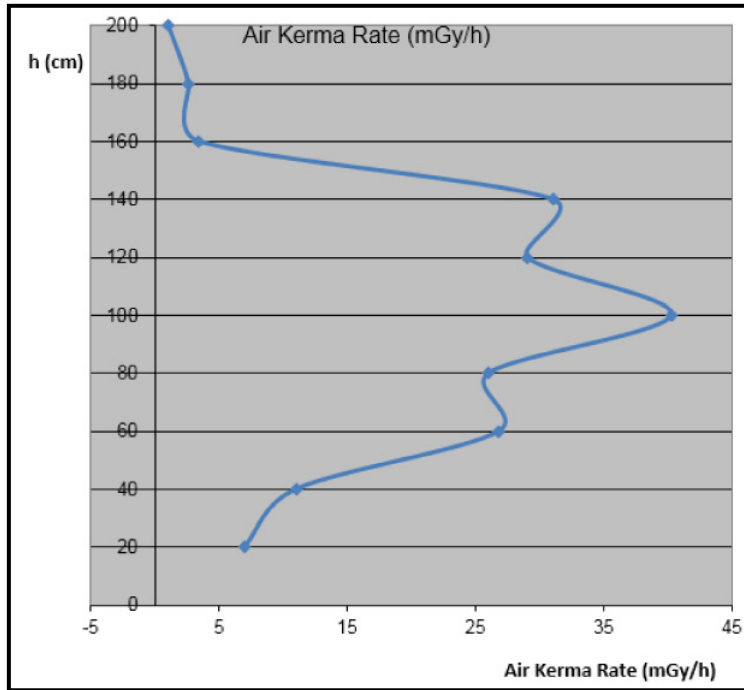

Dispersed radiation in occupied area, for version with **FPD 2121 with rotating anode.**

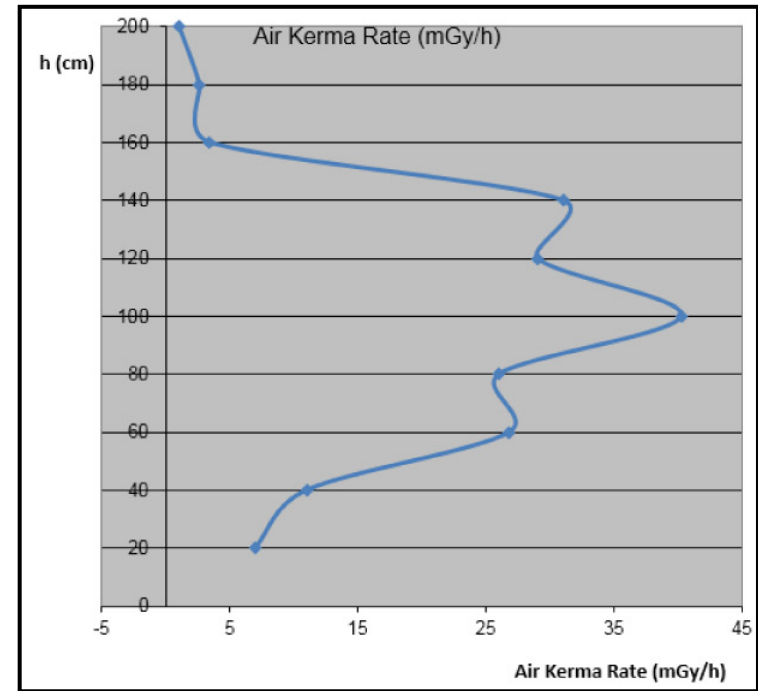

Dispersed radiation in occupied area, for version with **FPD 3030 with rotating anode.**

1.7 ISOKERMA MAPS (according to EN60 601-2-43)

In accordance with Standard EN60601-2-43 (paragraph 203.13.4), below are details of the two most common isokerma map configurations.

1.7.1 VERTICAL PLACEMENT

Measurement conditions:

- **HQ** fluoroscopy, **Pulsed curve 4**, rate: **8 fps**.
- Detector **Nominal field**.

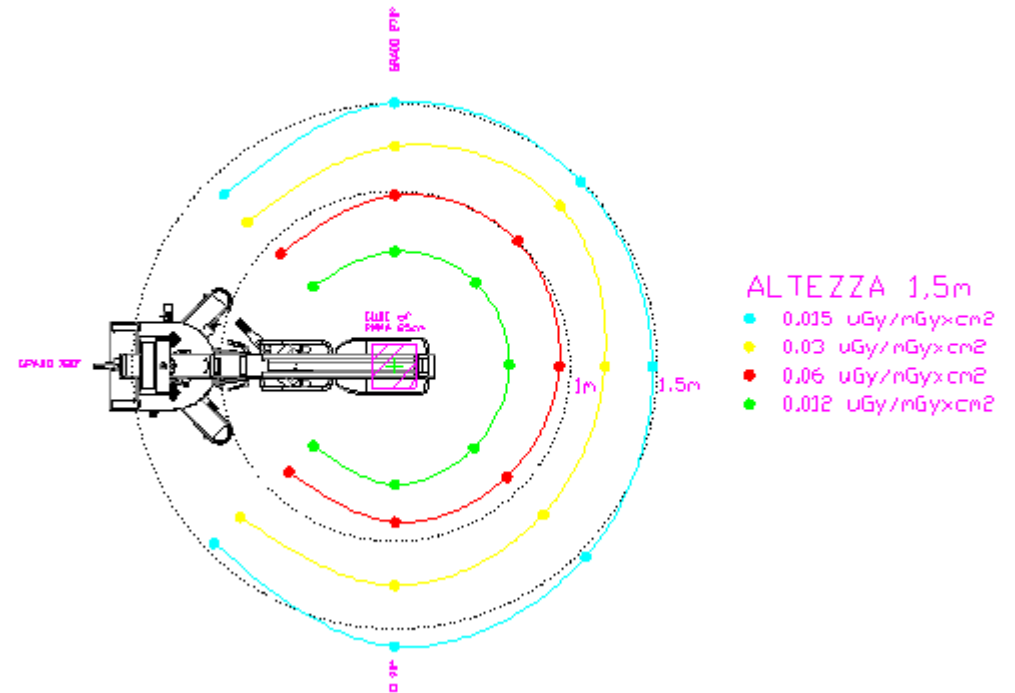
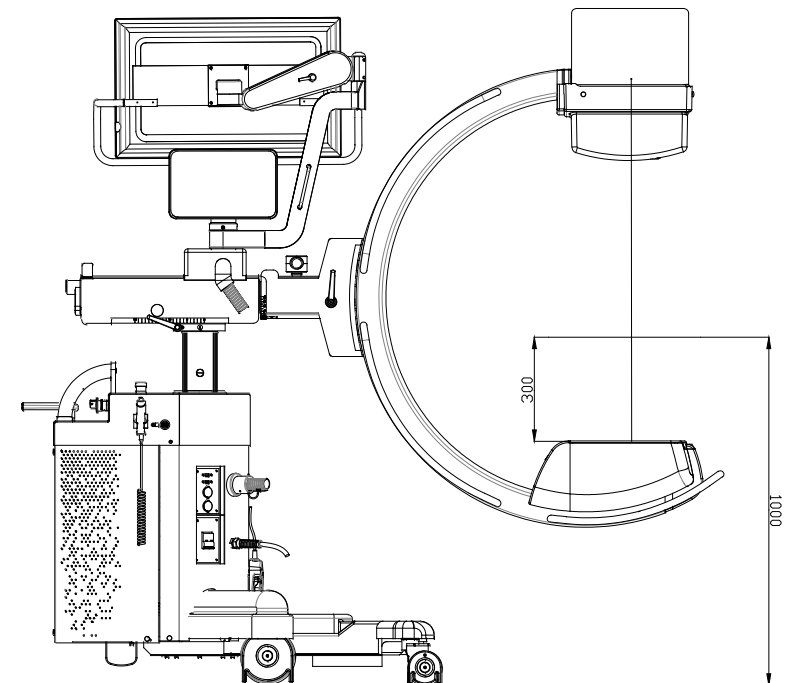

1.7.2 HORIZONTAL PLACEMENT

Measurement conditions:

- HQ Fluoroscopy, curve 4, rate: 8 fps.
- Detector **Nominal field**.

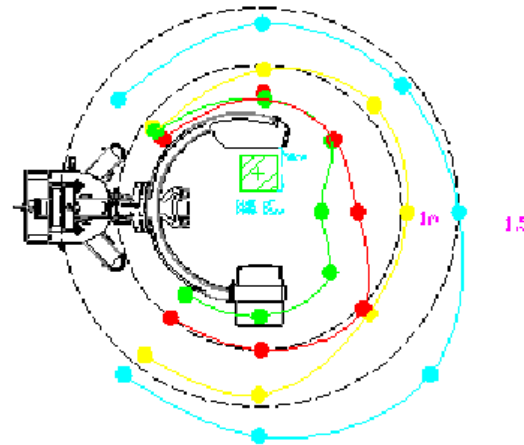
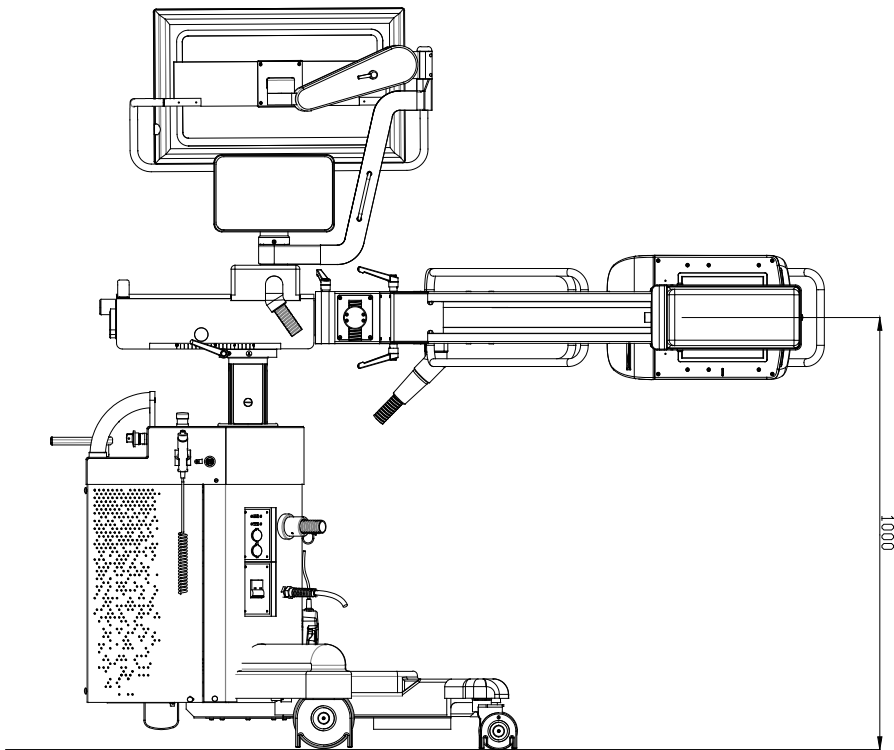

- ALTEZZA 1,5m
- 0,015 $\mu\text{Gy}/\text{mGy}\times\text{cm}^2$
 - 0,03 $\mu\text{Gy}/\text{mGy}\times\text{cm}^2$
 - 0,06 $\mu\text{Gy}/\text{mGy}\times\text{cm}^2$
 - 0,012 $\mu\text{Gy}/\text{mGy}\times\text{cm}^2$

1.8 DAILY CHECKS

1.8.1 CHECKING THE DOSE LEVEL

To minimize the residual risk of X-ray emission at the wrong dose, it is required to perform the following test every day, before using it on patients (see details below).

You need to compare the kV and mA values automatically set by the EM equipment for the envisaged working conditions with those detected under the same conditions during installation. These values are indicated in the Test Sheet filled in by the installer.

Regular checks that these values correspond will ensure the efficiency of the automatic dose control system.

- a) Select the exam **DAILY TEST (*)**. Check that the following configuration has been set:
- Nominal detector field (21x21cm² or 30x30cm² depending on the detector model installed),
 - X-ray collimator completely opened.

- b) On the monobloc, place the **aluminum** plate with **21 mm (Al)** thickness which has been delivered with the device,

- c) Give the **Low Dose Fluoroscopy** command by pressing the X-ray pedal on the left:
- Check that the kV and mA automatically set by the device are equal (or within the tolerances) to those indicated in the test sheet.

- d) Then give the **High-Quality Fluoroscopy** command by pressing the X-ray pedal on the right:
- Check that the kV and mA automatically set by the device are equal (or within the tolerances) to those indicated in the test sheet.

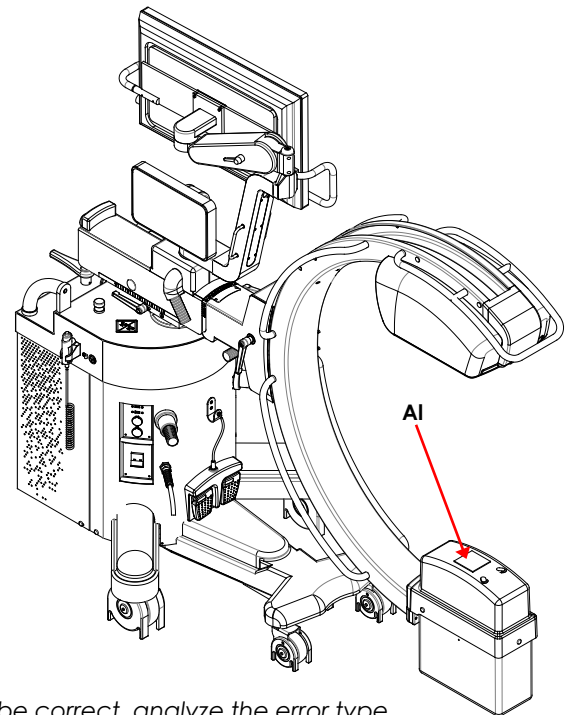

In case the kV and mA values collected should not be correct, analyze the error type. If there is a probability of a fault condition, stop using the device and request an intervention by the technical service.

The following table shows the typical kV and mA values which were collected in our factory with the aforementioned configuration settings:

	Version FPD 2121 (@4 fps)		Version FPD 3030 (@4 fps)		Tolerances	
	kV	mA avg	kV	mA avg		
Low Dose	58	0.29	58	0.29	±1kV	± 0,2mA
High Quality	58	0.60	58	0.60	±1kV	± 0,2mA

(*) The exam DAILY TEST is set in the factory with the following parameters:

- Image dose low dose fluoroscopy = 12 nGy/i, **Pulsed Curve 3** (0.4 – 10 mA, LF)
- Image dose High Quality fluoroscopy = 24 nGy/i, **Pulsed Curve 3** (0.4 – 10 mA, LF)
- With anti-scattering grid,
- Additional filter in the X-ray collimator being 1mmAl and 0,2mmCu.

1.8.2 CHECKING THE DOSE AREA PRODUCT (DAP)

To minimise the residual risk of incorrect dose measurement, we recommend checking the dose level every day, before using it on patients (see details below).

- a) Select the exam **DAILY TEST** (*). Check that the following configuration has been set:
 - Nominal detector field (21x21cm² or 30x30cm² depending on the detector model installed),
 - X-ray collimator completely opened.
- b) On the monobloc, place the **aluminum plate with 21 mm** thickness which has been delivered with the device as specified in the previous paragraph.
- c) Give the Low Dose Fluoroscopy command in automatic mode and check that the DAP increase for an X-ray emission of 20 seconds is equal (or within the tolerances) to the value indicated in the test sheet.

The tables below show the typical DAP increase values which were collected in our factory with the aforementioned configuration settings:

Version FPD 2121 (@4 fps)				
	kV / mA	X-ray emission duration	Beam dimensions RX	DAP increase (uGy x m ²)
Low Dose	58 / 0,29	20 seconds	21 x 21 cm ²	1,3 ± 50%

Version FPD 3030 (@4 fps)				
	kV / mA	X-ray emission duration	Beam dimensions RX	DAP increase (uGy x m ²)
Low Dose	58 / 0,29	20 seconds	30 x 30 cm ²	2,5 ± 50%



Find out the reason for the error if the actual dose values do not fall within the tolerance limits. If there is a probability of a fault condition, stop using the device and request an intervention by the technical service.

(*) The exam **DAILY TEST** is set in the factory with the following parameters:

- Image dose low dose fluoroscopy = 12 nGy/i, **Pulsed Curve 3** (0.4 – 10 mA, LF)
- Image dose High Quality fluoroscopy = 24 nGy/i, **Pulsed Curve 3** (0.4 – 10 mA, LF)
- With anti-scattering grid,
- Additional filter in the X-ray collimator being 1mmAl and 0,2mmCu.

1.8.3 CHECKING THE MAX X-RAY COLLIMATOR APERTURE

With the collimator, fully open, check that this is still visible on each edge of the image: this ensures against the risk of excessive exposure resulting from either the incorrect calibration or the malfunctioning of the collimator.



*If you cannot see the edge of the collimator when this is fully open, try closing this manually by using the relevant command on the control panel.
If not, call Technical Service and ask them to make the necessary adjustments.*

1.8.4 CHECKING THE SAFETY OF THE MOTORISED UP/DOWN C-ARM MOVEMENT

The safety circuit protecting against accidental movement of the C-arm column must be tested every day, **within 20 seconds from switching the equipment on**.

- To do this: press both an UP and a DOWN key for a few seconds;
- on releasing these:
 - o the column will not move if there is no problem;
 - o the column will move by about 1 cm if there is a problem in the safety circuit, first up and then down.



If faulty, do not use the equipment and call the Technical Service.

You also need to make sure that the 2 emergency stop buttons on the upper part of the equipment are working properly: press one of these and make sure the column cannot move.

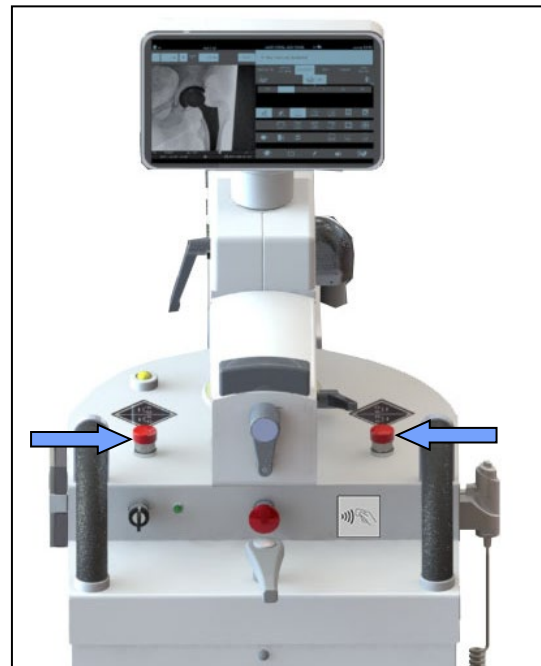

1.8.5 CHECKING THE MONITOR ADJUSTMENTS

For details on how to check the monitor adjustments, please refer to *Paragraph 2.1, Part 2*.

1.9 END OF USE

Switch the equipment off at the end of a session as follows:

- Bring the equipment into parking position (see paragraph 1.10 below).



Parking position

- Close the current study and return to the Study List by pressing this key:



- Press the **Shutdown** key in the Study List:



- Select the **Turn off** (Shutdown) command:

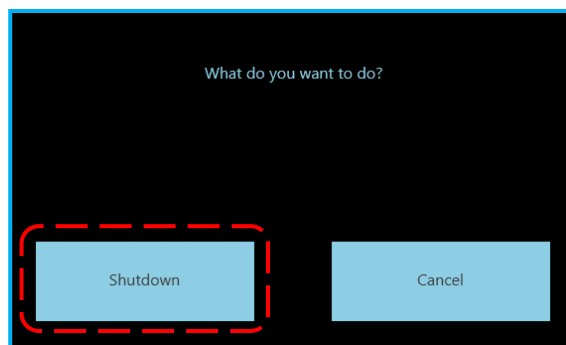

- Wait for the monitor to turn itself off: **the screen should be black and the power LED should turn from green to yellow.**



Problems can arise in the PC operating system if you switch the equipment off before the Shutdown procedure has been completed.
It is therefore important that you follow the above procedure to switch the PC off.

- Then switch the system off by turning the key to "OFF" (0).



- Unplug the power cable and then wind it around its supports.



Never unplug the cable before the monitor unit has been switched off.

1.10 PARKING AND MOVING

To ensure parking and moving safety, we recommend to read carefully *Paragraph 2.3, Part 1 of this Manual ("Residual Risks")*.



Warning: Before moving the C-arm, be sure that it cannot collide with people or objects.

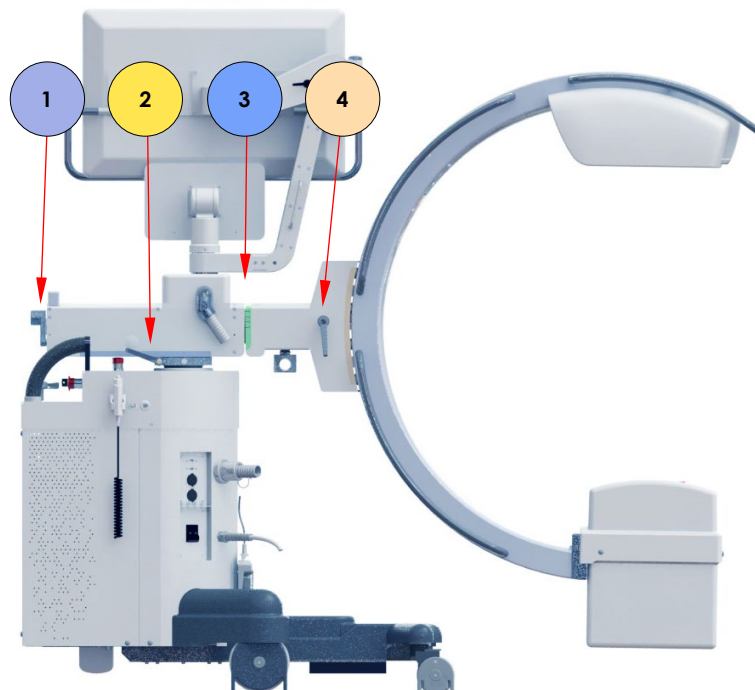

The correct **parking and transport position** is shown below:

Note: see paragraph 1.3 above on how to use the brakes.

- C-arm fully lowered

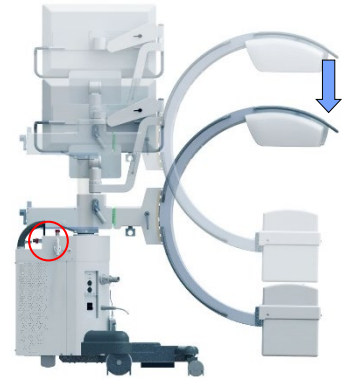

- Horizontal trolley fully retracted and locked in position by Brake 1,

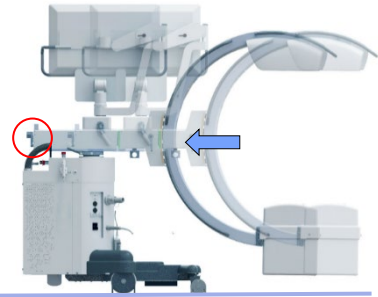

- Wig-wag at 0°, locked in position by Brake 2

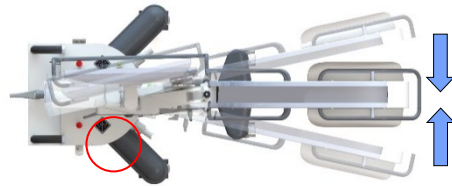

- C-arm rotated in the vertical position and locked in position by Brake 3

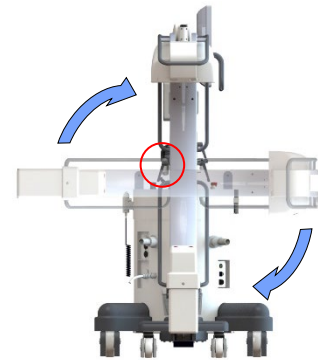

- Monoblock and detector in line in vertical position and locked by Brake 4

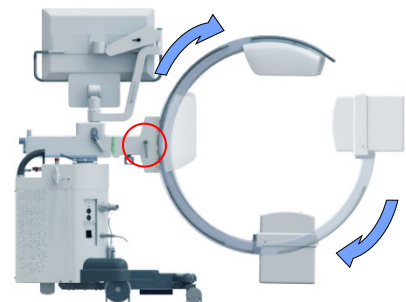

- Hook the monitor handle into the designated retaining support (see picture) and activate the brake of the support arm in order to prevent any uncontrolled movement.

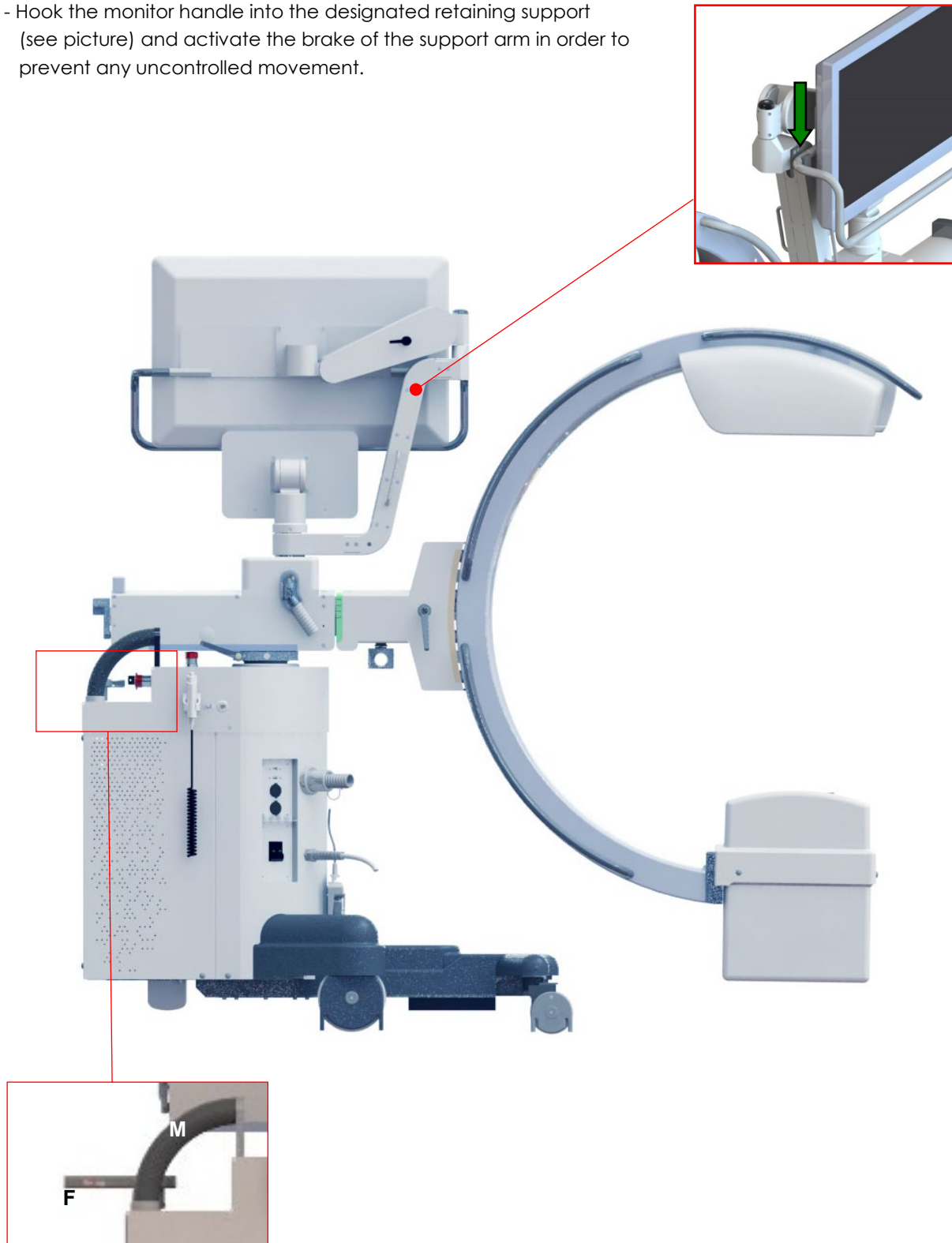

To **move**, release the parking brake (F) and use only the handles (M).
If necessary, turn the rear wheels using the steering lever (F).

Note: See also paragraph. 1.3.2: Moving the equipment.

2 **INSTRUCTIONS FOR USE**

2.1 **OPERATOR AUTHENTICATION (LOGIN)**

You need to log in by entering your user name and password in order to start using the EM equipment. There is no limit to the number of users who can register and log in.

There are three user levels, each being able to access different functions:

- NORMAL a normal user of the equipment,
- ADVANCED the person responsible for the equipment,
- ADMINISTRATOR the technician responsible for installing and servicing the equipment.

When switching on the EM equipment, the login window appears both on the **Main Monitor** and on the **Control Panel**:

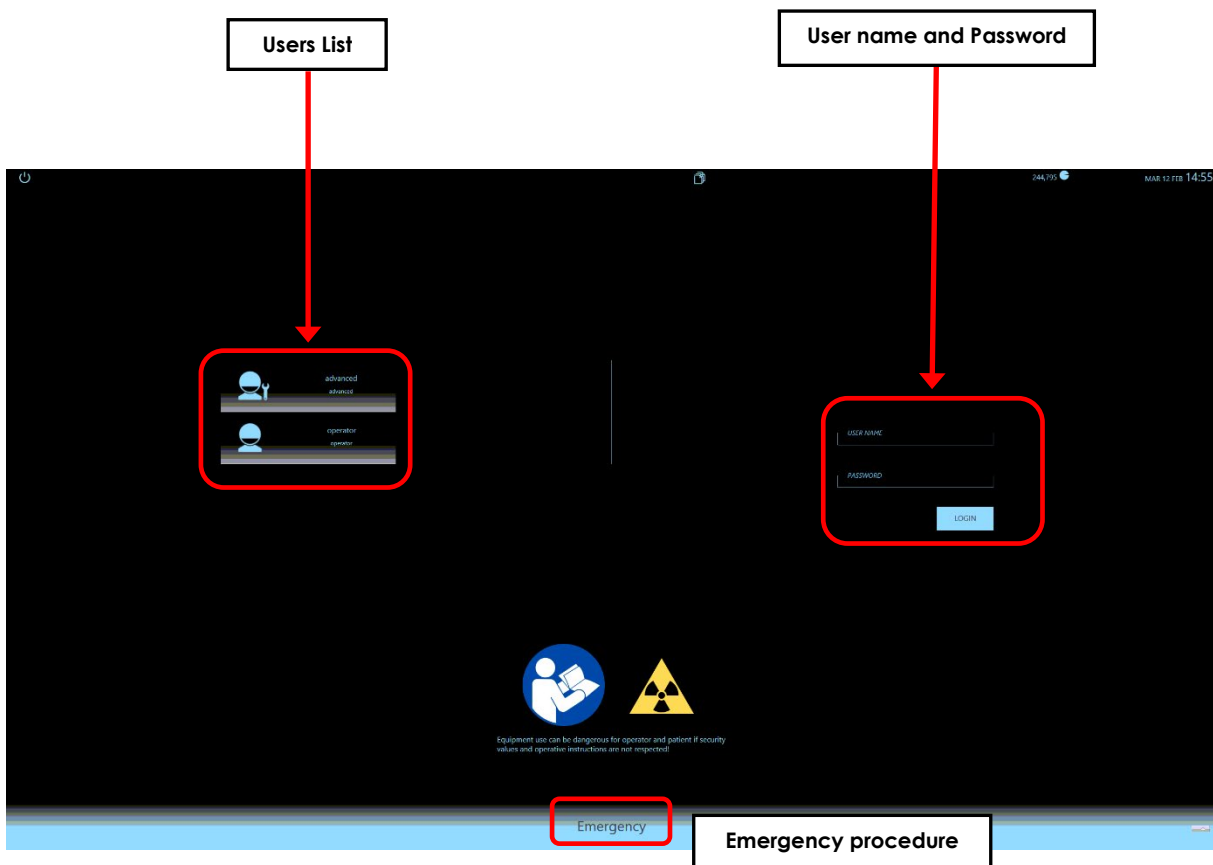

The login procedure can be carried out on the main monitor as well as on the Control Panel. Select your username from those in the list and then enter the password in the box provided. Confirm by pressing the LOGIN key.

If a badge has been assigned to the user, he will be able to log in by simply approaching this badge to the respective reader (for setup of this function, see paragraph 4.7, Part 2 of the Technical Manual).

Note: In an emergency, when you need to log in as quickly as possible, you can touch the EMERGENCY key to start using the equipment; there is no need to enter your user name or password. On using the EMERGENCY option, you immediately access the working frame, without having to enter the patient data first. You can enter the relevant data at a later date, after logging in as normal.

ATTENTION: In EMERGENCY mode, the modality Digital Radiography is not available.

After logging in, both the monitors display the Test Pattern so you can check the grey scale correct representation.

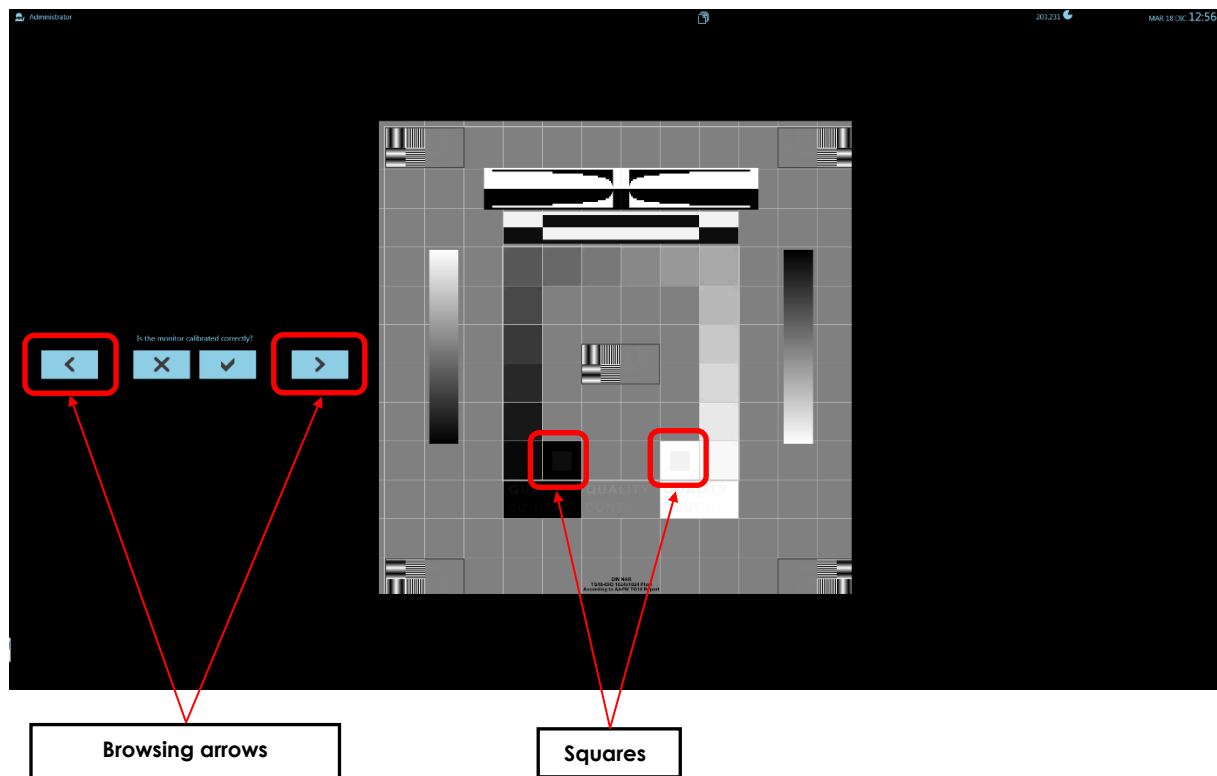

Check that the Test Pattern shown in the picture above is displayed correctly.

It must be possible to discern:

- the entire grey scale (0% - 100%),
- the grey square in the black box (0%, position **A**),
- the grey square in the white box (100%, position **B**).

If this is not the case, it might be necessary to have the monitor recalibrated (or replaced) **by the technical service**.

Note: It is possible to check the correctness of calibration on other images, too. Browse through the images with the relevant arrows. (aforementioned criteria still apply).

In the **Study List**, it has been saved a study containing all the Test Pattern images (named DICOM TEST PATTERN): this way, it is possible to check the goodness of the monitor representation whenever needed.

Then, the monitors will display the Study Worklist view.



1. Status bar
2. Lists/ Logout and shutdown commands
3. Study list
4. Command icons

Note: as a security feature, it is possible to enable the automatic log-off after an inactivity period (to be set into **Security Setup**: see Paragraph 4.10, Part 2 of the Technical Manual).

2.2 OPENING A STUDY

2.2.1 STUDY LIST FRAME

The Study List frame is split into 3 zones:

- List of studies to be performed (STUDY WORKLIST) – see paragraph 2.2.1.1
- List of studies already performed (STUDY LIST) – see paragraph 2.2.1.2
- List of query/retrieve studies (QUERY/RETRIEVE LIST) – see paragraph 2.2.1.3

2.2.1.1 STUDY WORKLIST (OPTIONAL)

Press the button indicated to open the Study Worklist:

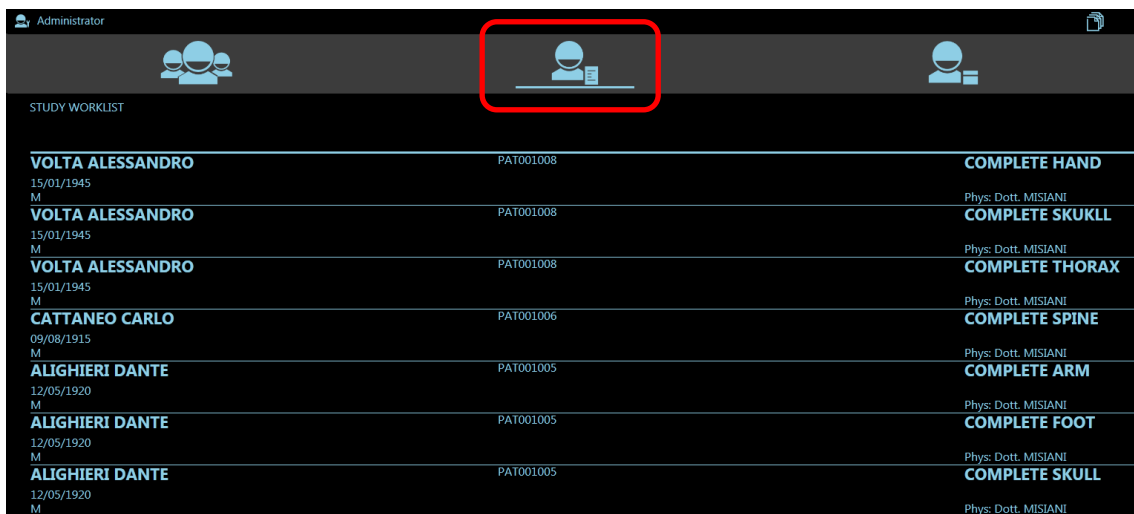

Each study can be identified using the following fields:

- Patient data: First name and Surname, Date of birth, Gender
- Patient ID
- Type of study required
- Operator who will carry out the intervention
- Accession Number

The studies are listed and grouped by their creation date. Groups are indicated by **bold lines**. Touch the study you want to open twice in rapid succession ('tap').

2.2.1.2 STUDY LIST

Press the symbol shown here to open the Study List:

Tap the study once to get a preview of the saved images.
Tap the study twice to open it and use the working frame commands.



2.2.1.3 QUERY/RETRIEVE LIST (OPTIONAL)

The icon shown here will give the access to the DICOM QUERY RETRIEVE function.



For a description of the DICOM QUERY RETRIEVE function, see *the Annexes, Paragraph 6.8, Part 2 of this Manual.*

2.2.2 ONLINE MANUALS

You can load the manuals for the equipment from the Study List frame (PDF format):
Touch **USER**, to open the **MENU** to:

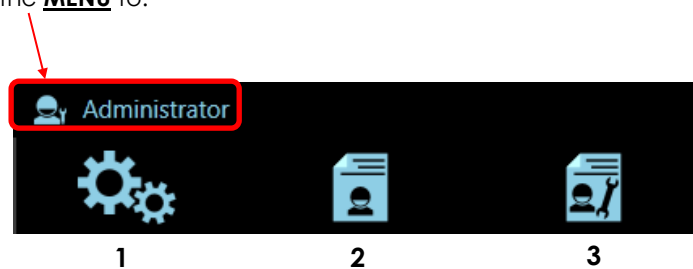

1) Access the setup menu (ADMINISTRATOR / ADVANCED users, only)

2) Open the **User Manual**

3) Open the **Technical Manual** (ADMINISTRATOR / ADVANCED users, only)



2.2.3 CREATING A NEW STUDY

There are two different ways to create a new study from the **Study Worklist** frame, either on the Control Panel or Monitor:



1. **Manually**, entering the data via the touchscreen keyboard



2. or **automatically** with the data received from the service **DICOM WORKLIST**.

Touch the first key to access the menu for manual entry of the study data and fill in the following fields:

Patient data:

- First name and Surname (mandatory)
- Unique identifier code
- Date of birth
- Gender
- Weight
- Height

Exam data:

- Type of exam (mandatory field if you wish to create more than one study for the same patient)
- Exam ID code
- Accession Number
- Name of medical professional (it is possible to select within the user list, too)
- Name of hospital
- Name of department/ward
- Maximum Air Kerma (Gy): Set the maximum Air Kerma value (in Gy) for the study, beyond which the Control Panel will display the alarm message "POSSIBLE DETERMINISTIC EFFECTS".

New patient

Patient data

Name [] Surname []

Birthdate *dd/MM/yyyy* Sex male female other

Weight [] Height []

Patient ID []

Users List

Exam [] Exam ID []

Acc. Number [] Physician []

Hospital [] Department []

Maximum Kerma Gy []

Study data

To add another study (max 3 studies)

Confirm the data and return to the Study

Confirm the data and open the working frame

Cancel

You can enter up to 3 studies for the same patient. These will be treated as independent single studies. The first study is automatically opened when you access a patient directly from the working frame.

Attention: before to save the just created study, the operator must check the accuracy of the data entered and that the date the study is automatically saved with, it is today's date.

Touch the second key to import study data from DICOM WORKLIST:

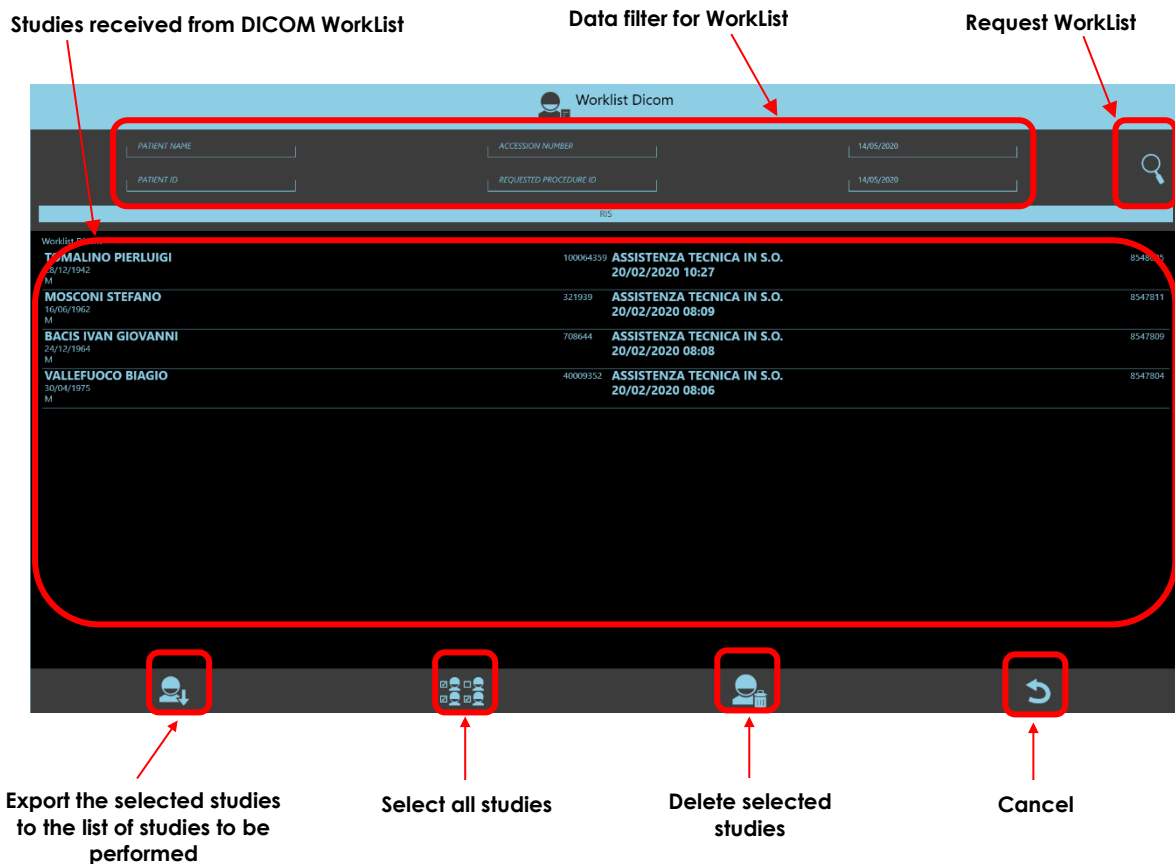

Select the DICOM WORKLIST device from among those in the list to receive the studies.

- You may wish to use some search filters and set some **field values**, such as:
 - the surname and/or name of your patient,
 - patient ID code,
 - accession number,
 - requested procedure ID code,
 - studies within a date interval.

If a PATIENT NAME search is unsuccessful, try again, this time adding an asterisk * before and after the search criteria (this inconvenience is due to the configuration of the WORKLIST server).

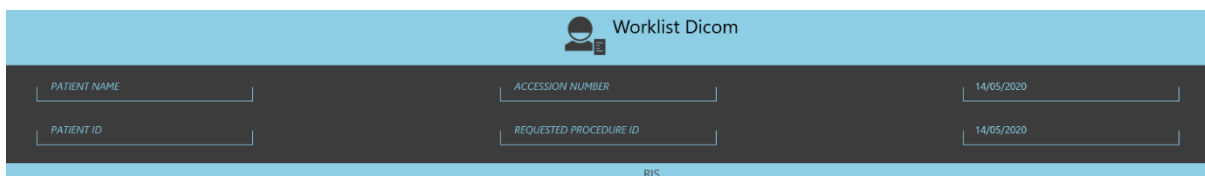

Note: it is possible to display the search fields **Accession Number** and **Requested Procedure ID** only if enabled during system configuration, in the **Dicom Setup** menu (see Paragraph 4.5.2.3, Section 2 of the Technical Manual).

- Touch the **SEARCH** (Magnifying Lens) key to start searching.
- You can then **SELECT** single studies in the list by simply touching the patient's name. You can also select all the studies by touching **KEY 2**.
- You can **EXPORT** one or more studies and add these to the Study Worklist by touching **KEY 1**.
- You can **DELETE** one or more selected studies by touching **KEY 3**.



2.2.4 OPENING A STUDY



Tap the study you want to open from those listed in the STUDY WORKLIST (yet to be performed); the working frame opens, letting you acquire images (see image above).

You can also open a previous study to add some new images or process the existing images. In this case, select the study from those in the STUDY LIST (previous studies) by tapping it.



When opening a study, the WORKING FRAME screen will appear:

The Monitor shows the images during X-ray emission (LIVE images) and the images, if any, saved to Hard Disk.

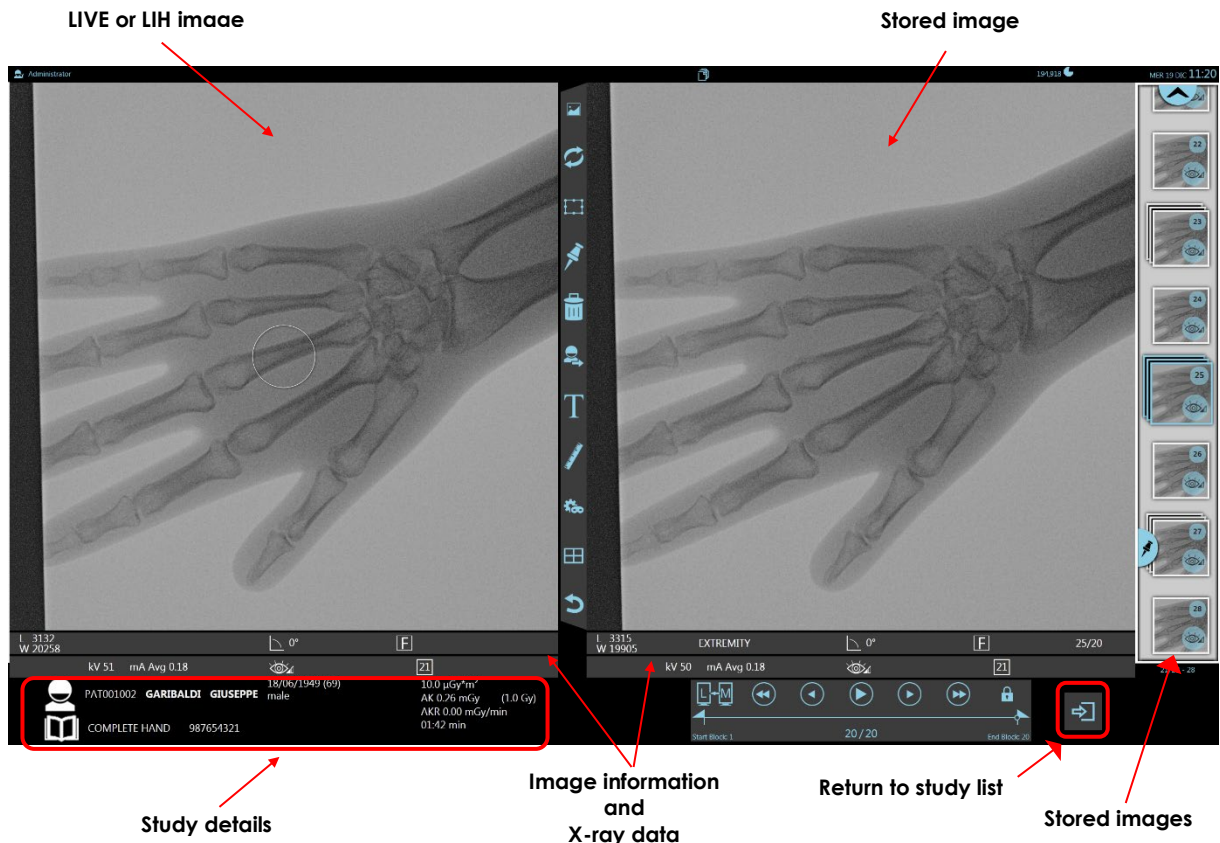

2.2.4.1 DETECTOR DARK CALIBRATION

Outside the WORKING FRAME, the system behaves in two different ways, according to what has been set in the **General Settings** menu (See Paragraph 4.2, Part 2 of the Technical Manual).

1. The system automatically calibrates the Offset of the detector (*Dark Calibration*) in background.
2. The system automatically calibrates the Offset of the detector (*Dark Calibration*) when a new study is created, too. During this procedure, the following window appears on the monitor and the control panel:

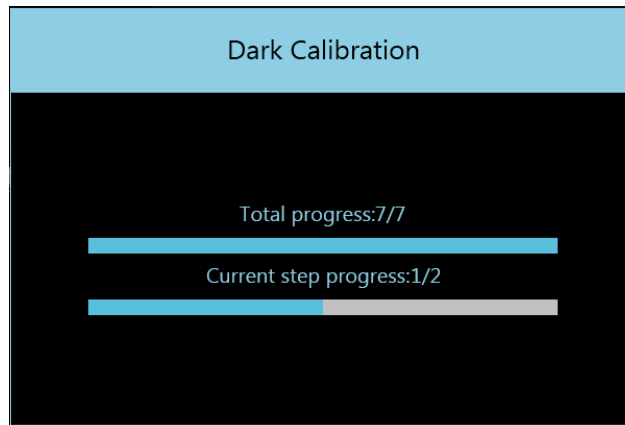

The complete calibration procedure takes about 25 seconds, at the end of which the detector will be ready for image acquisition.

When a study is open, the system **automatically** refreshes the **fluoroscopy offset** in background, during pauses between acquisitions; instead, **radiography offset** can only be refreshed **manually** (it differs between offset calibration for fluoroscopy images and radiography images).

The operator is advised when the **radiography offset** is expired thanks to the dedicated key (in figure below), that starts blink once every 3 seconds.

It is always possible to acquire a radiography image, even if the offset is no longer valid. However, it is recommended to manually refresh the radiography offset as soon as possible, pressing the dedicated key, for at least 3 seconds: image acquisition is inhibited during the process.



2.2.5 SELECTING AN EXAM TYPE

The equipment lets you choose among different exam types where certain parameters can be set so as to optimize the performances in image acquisition and image display.

The number of exams and the settings of the respective parameters are defined during the installation of the equipment in the **Exam Setup** menu (see paragraph 4.4, Part 2 of the Technical Manual) and after consultation with the user.

It is possible to browse through the exam lists on the Control Panel by using the respective arrows.

When selecting the exam, the main parameters of the function and of the acquisition mode will be assigned automatically and according to the values which have been preset to each pedal of the footswitch (or of the handswitch) for X-ray command.



Note: For a detailed description of the exam settings and the related parameters, see the annex to paragraph 6.10, Part 2 of this manual.

Below you will find a sample exam; the selected exam will be highlighted in blue:

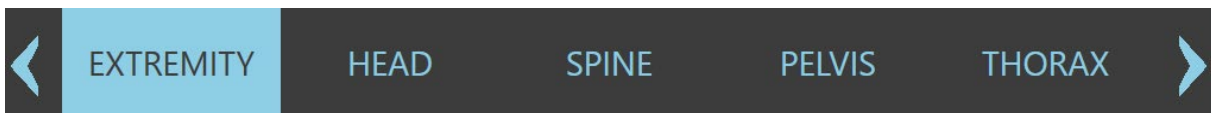

Check that the automatically set parameters are those you require. The default parameters set in the factory must be checked and changed if necessary, as required by the user.

2.2.5.1 PRESET EXAMS

<u>EXAMS</u>	<u>APPLICATION</u>
EXTREMITY	Fracture repair for extremities and other bones.
HEAD	For Neuromodulation, Spine Fixation, Laser Nucleolysis and Pain therapy procedures.
SPINE	For vertebral fracture repair, pain therapy procedures and scoliose-lordose correction procedures.
PELVIS	To examine pelvis bone structures, especially to repair fracture.
THORAX	For inserting catheters in the thoracic region.
PACEMAKER	For implanting pacemakers or defibrillators.
ERCP	Endoscopic retrograde cholangiopancreatography procedure and for examination of abdominal organs, where a high contrast is required because of organs movement.
VASCULAR	Control of peripheral arterial bypasses (femoral, popliteal arteries etc.) and Enderterectomy procedures.
VASCULAR HQ	Abdominal Aortic Aneurysm procedures and other vascular procedures in abdomen.
VASCULAR CEREBRAL	Control of Intracranial aneurysms.
PAIN MANAGEMENT	For all bone structures, suitable to be used for Neuromodulation procedures, together with image subtraction technique, too.
UROLOGY	Urological and pelvic region intervention.
ELECTROPHYSIOLOGY	Electrophysiology procedures with great organ movement and very long procedures times.
DAILY TEST	Daily procedure, to be accomplished before using the device, in order to check that equipment works correctly.

2.3 IMAGE ACQUISITION



Before carrying out any exposure, make sure that all the necessary irradiation protection measures have been taken.



Before giving the X-ray command, also make sure that the patient bed has been earthed via the equipotential connector on the stand.



During X-ray emission, always make sure that the edge of the collimator can be seen on the image: if not, call the Technical Service as there is the risk that the collimator is not working and remains open at an excessive value.



If the COLLIMATOR FAULTY alarm is active, you can continue fluoroscopy exposures in order to complete the procedure. Any such exposures should, however, be as brief as possible and only if necessary.
Contact Technical Service to restore the equipment to proper working order.



The X-ray emission is indicated by the yellow light, present on the stand.

Note: it is suggested to **not** connect the EM equipment to Hospital Network if not required (for example, during surgery).

2.3.1 SELECTING THE ACQUISITION MODE

Possible acquisition modes:

- **Fluoroscopy:**

- **Low Dose** Fluoroscopy
- **High Quality** Fluoroscopy
- Fluoroscopy in **Peak Opacification + Road Mapping** mode (optional)
- Fluoroscopy in **DSA** mode (optional)

- **Digital radiography**

Note: the **PaxScan 2121** and **3030** panels are indicated for use in generating real time fluoroscopic images in patients where medically indicated. They are also indicated for use in generating radiographic images of human anatomy.

When opening the exam, the acquisition modes are assigned automatically and according to the values which have been preset to each pedal of the footswitch (or to each handswitch button).

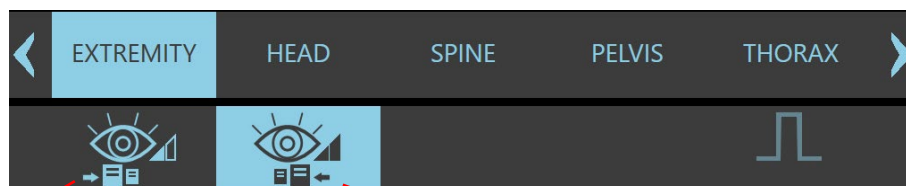

Mode assigned to the left pedal and the lateral function button

Mode assigned to the right pedal and the two-stage function button

Modification of these settings is possible temporarily but will be limited to the current exam. Once you select a new acquisition mode from those available for this exam, this new selection will determine the new mode assigned to the **right pedal** (or to the **two-stage function button**).

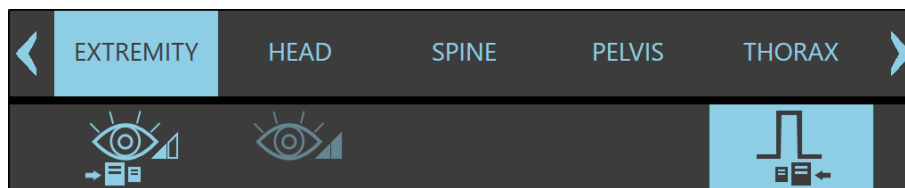

New mode assigned to the right pedal and two-stage function button

On startup and at the selection of a new exam, the device will be preset for automatic fluoroscopy dose control. The kV and mA values will be set automatically according to the examination subject.

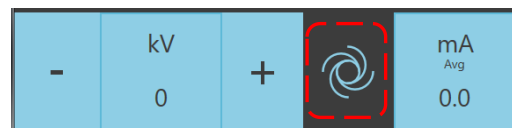

This automatic regulation is generally calculated on a central Region Of Interest of the image (ROI). ROI dimensions are set to be, in normal conditions, completely inside the anatomic section under exam. If it is not possible to have the anatomic part in the center of the field, it is possible to manually move the ROI in the needed point. When you press the "abc ROI" icon, a little green square appears in the center of the image on the control panel screen. Simply touch the screen at the point where you want the ROI square to appear; the kV and mA values will be automatically recalculated. Press the **abc ROI** icon again to return to the standard setting. The function ends when you change detector field or exam.



You can always control the dose manually:

- select the **manual mode**,
- adjust the kV as required using the keys to **decrease (-)** and **increase (+)**.



2.3.2 ACQUISITION RATES

The fluoroscopy emissions can be carried out at different rates of X-ray pulses per second; the values suggested on Control Panel are the following:

1, 2, 4, 8, 15, 30 frames per second.

2.3.3 LOW DOSE FLUOROSCOPY

The **Low Dose** fluoroscopy is recommended for all centering and positioning operations during surgical and interventional procedures.

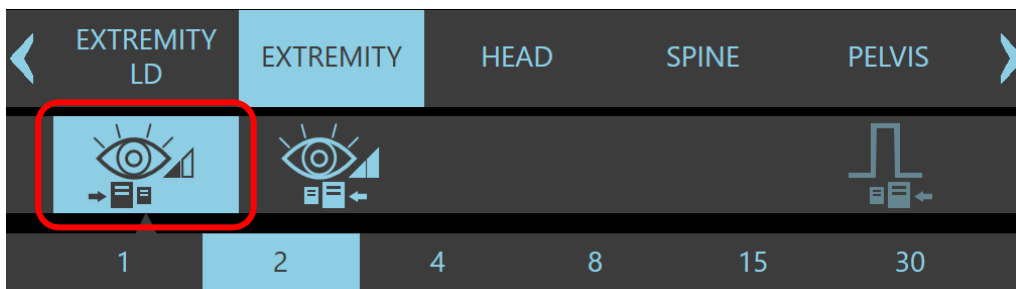

X-ray emission command is given with the left pedal or with the lateral switch of the bi-functional handswitch.

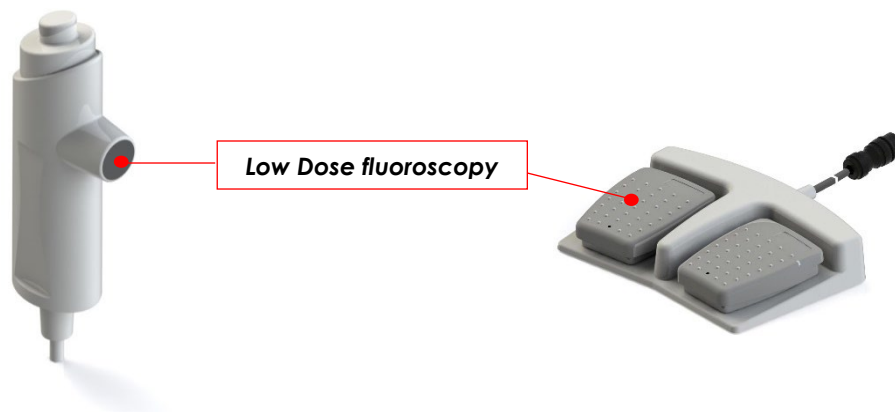

The number of X-ray pulses per second is programmed in the exam setup and will be selected automatically on opening the study (see Paragraph 4.4, Part 2 of the Technical Manual)

Warning:
 Pressing the X-ray command (footswitch or handswitch) briefly for less than 0.5 seconds will trigger an X-ray emission of 0.5 seconds duration.
 Thanks to this functionality the monitor will display a correctly exposed image even if the X-ray command is pressed only for a short moment.

The yellow warning light on the stand and an acoustic signal (if enabled) will indicate the X-ray emission.

The **Control Panel** displays:

- The acquired image,
- The indication: **FLUOROSCOPY** (during x-ray emission)
- The value of the kV and average mA,
- The x-ray pulse duration (in ms),
- The fluoroscopy time (minutes and seconds),
- The available Heat Units (%) and the temperature of monoblock,
- The total dose * area during the study (**DAP**),
- The total Air-Kerma during the study (**Air-Kerma**),
- The **Air Kerma Rate**

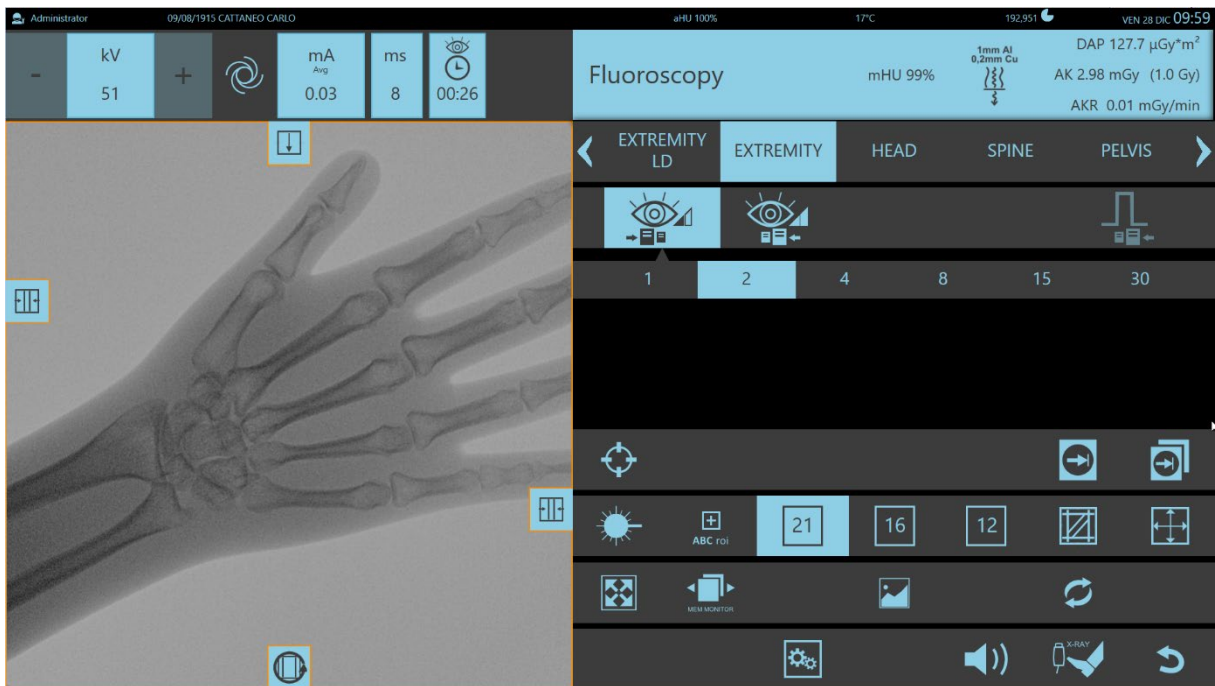

The **Live Area** of the **Monitor** displays the following:

1. The acquired image,
2. The **kV** and **mA** values,
3. The dose data of the study, indicated in the following order:
 - The total dose * area value of the study (**DAP**)
 - The total Air-Kerma of the study (**Air Kerma**)
 - The **Air Kerma Rate**
 - The actual X-ray emission time

X-ray emission is interrupted on releasing the command and the last image acquired is frozen on the **C.P.** and the **Live area** of the **Monitor**. This image is marked with the letters **LIH** (Last Image Hold).



During the installation phase of the equipment, it is possible to determine whether all Low Dose Fluoroscopy images will automatically be saved to hard disk, or if it should only save the LIH (*Last Image Hold*), or no image at all. Usually, the settings are made to save only the LIH.

In case the exam is not set to automatically save the images, it is nonetheless possible to save the required images during the exam using the manual commands.

- In order to **save the single image** currently acquired:
 - Press the **SAVE IMG** button on the Control Panel,
 - Or the corresponding key on the remote control,

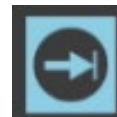

You can also save the **LIH image** on the hard disk using the **SAVE IMG** button or the key on the remote control.

- To save **a whole run**:
 - Press the **SAVE RUN** button on the Control Panel,
 - or the corresponding key on the remote control.



All the images will be saved from the moment you use this key to the end of exposure. This function remains valid only for the current X-ray emission. To save a run of images acquired with subsequent X-ray emissions, touch the **SAVE RUN** key again.

This function is disabled the next time you touch the **SAVE RUN** key again.

At the end of the emission, the Monitor will display the thumbnails of the images saved to the hard disk.

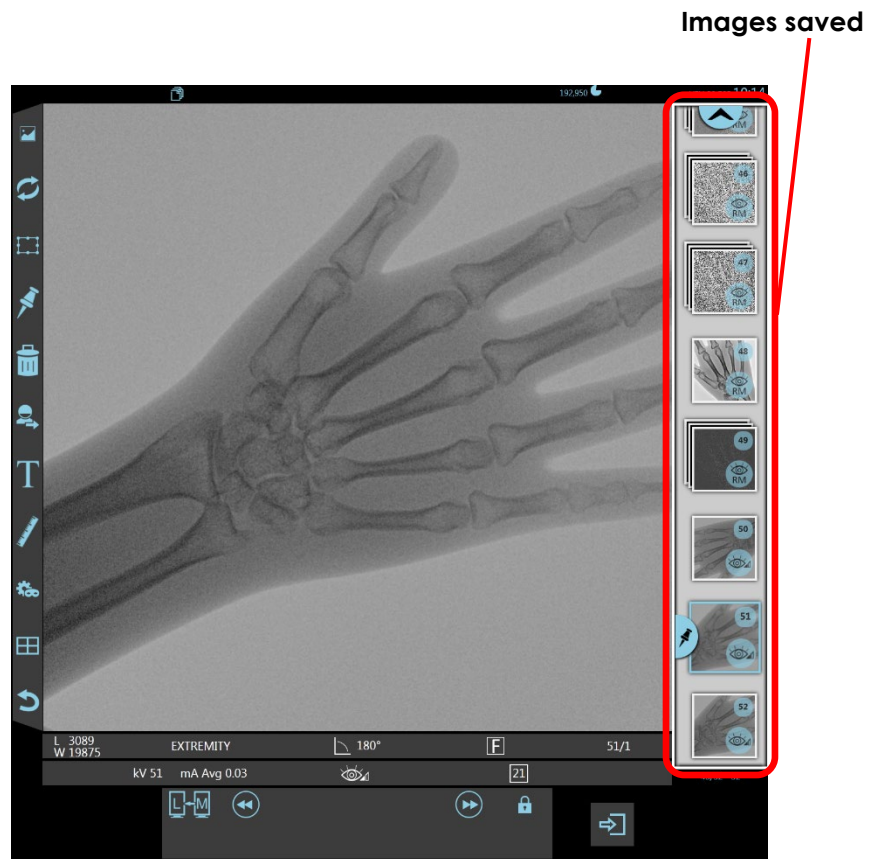

The images saved on the hard disk can then be improved using the post-processing functions or they can be sent to the printer and/or to a STORE DICOM server.

Note: You can transfer as many images as you want during the study (the number is only limited by the storage capacity of the HD).

- Your choice of exam also defines the type of image processing possible during acquisition:
 - Recursive filter to reduce noise caused by movement,
 - Dynamic control of the image latitude and contrast (DRC),
 - Edge smoothing or sharpening.

If necessary, you can change the programmed processing for the exam during the study. When pressing the indicated key, this will open the change menu:

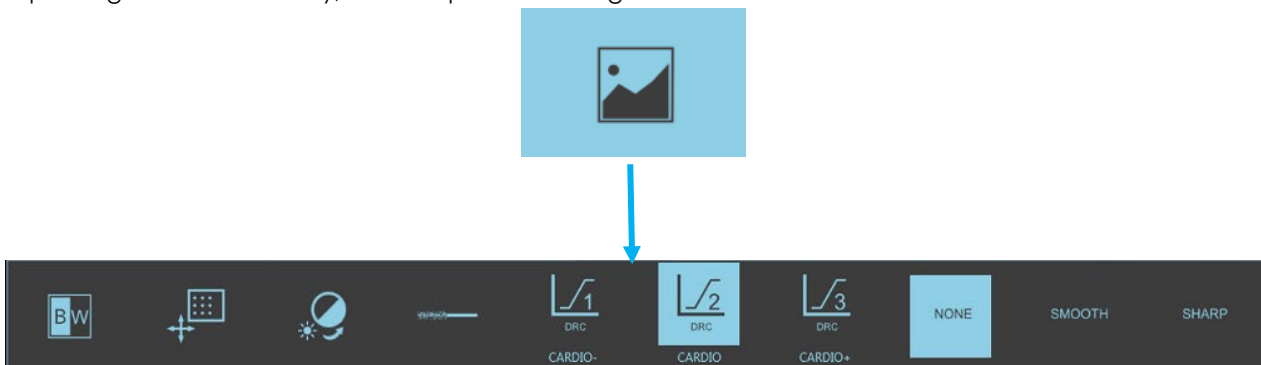

Note: Any such changes are only valid for the current exam. On changing the exam type or opening a new study, the default processing settings are restored to those set originally.

- ❖ **Grey scale inversion:** Invert the grey scales of the image by pressing the respective key.



- ❖ **Recursive filter:** you can add or remove the smart filter that detects movement and so make the filter more sensitive or less sensitive to any shifts in the patient or instruments (e.g. a catheter).

This adaptive component (MOTION DETECTION) is very useful when using a 'heavy' recursive filter. It identifies any moving parts in the image (e.g. a catheter) and reduces the weight of the filter in that area, thus avoiding the 'dragging' effect.

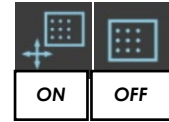

- ❖ **Window and Level Reset:** This key allows to restore **W** and **L** image values, as they were at the acquisition.



- ❖ **Noise Reduction:** This function allows to reduce possible noise on the image by increasing the value of this factor; the **range** goes from **0** to **10**.



- ❖ **Dynamic contrast control:** this lets you choose one of the values set for the specific exam type. The intermediate value is normally adopted when you select an exam type. The sub-menu lets you select less contrast (left-hand key) or more contrast (right-hand key).



- ❖ **Edge smoothing or sharpening:** you can decide to remove this filter or select either the SHARP filter or the SMOOTH filter as programmed for the specific exam type. The sub-menu offers three choices among these conditions.

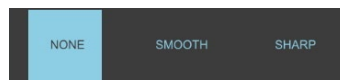

2.3.4 HIGH QUALITY FLUOROSCOPY

The **High-Quality** fluoroscopy is recommended whenever a higher image quality is required than the one obtained with the Low Dose fluoroscopy.



The number of X-ray pulses per second is set automatically on opening the exam (see Paragraph 4.4, Part 2 of the Technical Manual)

However, this value can be changed by one of the other values available.

You can also change the emission rate using the remote control



- The X-ray emission can be started by pressing the footswitch or the handswitch command.



Warning:



Pressing the X-ray command (footswitch or handswitch) briefly for less than 0.5 seconds will trigger an X-ray emission of 0.5 seconds duration.

Thanks to this functionality the monitor will display a correctly exposed image even if the X-ray command is pressed only for a short moment.

The yellow warning light on the stand and an acoustic signal (if enabled) will indicate the X-ray emission.

The **Control Panel** displays:

- The acquired image,
- The indication: **HIGH-QUALITY FLUOROSCOPY** (during x-ray emission),
- The value of the kV and average mA,
- The x-ray pulse duration (in ms),
- The fluoroscopy time (minutes and seconds),

- The available Heat Units (%) and the temperature of monoblock,
- The total dose x area during the study (**DAP**),
- The total Air-Kerma during the study (**Air-Kerma**),
- The **Air-Kerma Rate**.

The **Live area** of the **Main Monitor** displays the following:

1. The acquired image,
2. The **kV** and **avg. mA** values,
3. The dose data of the study, indicated in the following order:
 - The total dose * area value of the study (**DAP**)
 - The total Air-Kerma of the study (**Air Kerma**)
 - The **Air Kerma Rate**
 - The actual X-ray emission time

X-ray emission is interrupted on releasing the command and the last image acquired is frozen on the **C.P.** and the **Live area** of the **Monitor**. This image is marked with the letters **LIH** (Last Image Hold).



Exposure parameters (kV and mA)

Dose data of the study



Warning:

In case an exam requires the use of elevated peak mA the entrance Air Kerma for the patient **might exceed** the value of 88mGy/min (HIGH LEVEL COMMAND - HLC); Under these conditions, the equipment will emit a 500ms beeping sound every second. The use of this mode should be limited as far as possible in order to avoid an overexposure of the patient.

During the installation phase of the equipment, it is possible to determine whether all High-Quality Fluoroscopy images will automatically be saved to hard disk, or only the LIH or no image at all. The typical setting is to automatically save all the High-Quality Fluoroscopy images to the hard disk.

In case the exam is not set to automatically save the images, it is nonetheless possible to save the required images during the exam using the manual commands (see *previous paragraph*).

At the end of the emission, the Monitor will display the thumbnails of the images saved to the hard disk.

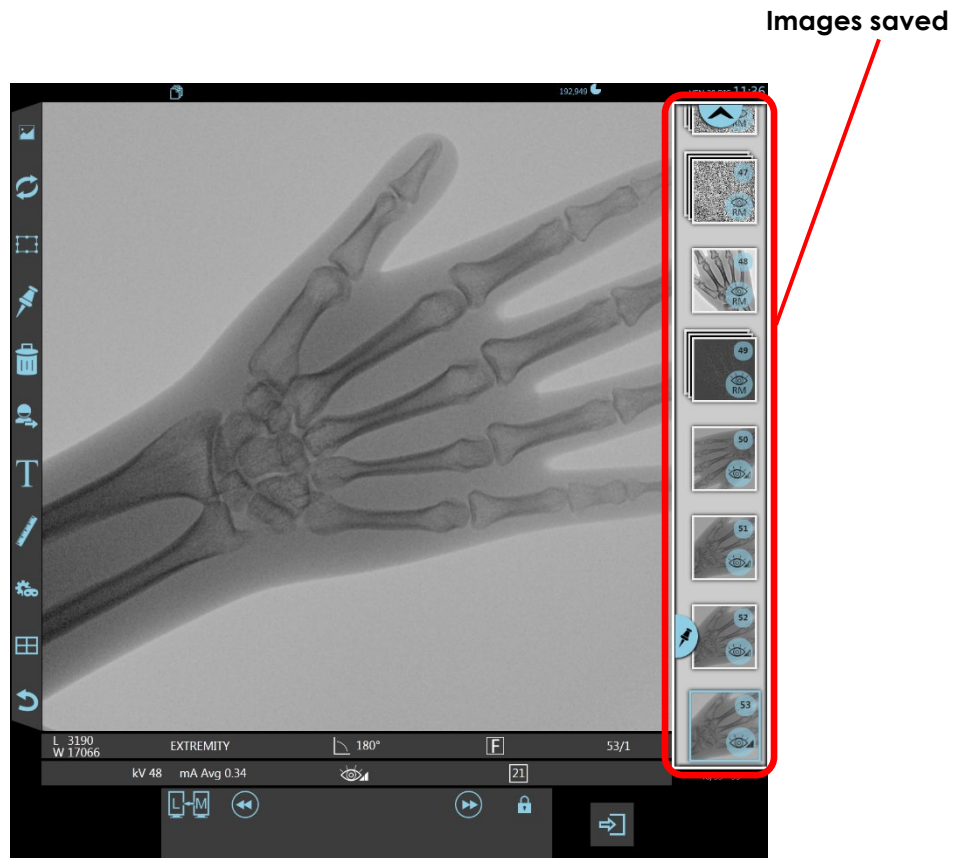

The images stored on the hard disk can then be improved using the post-processing functions or they can be sent to the printer and/or to a STORE DICOM server.

Note: You can transfer as many images as you want during the study (the number is only limited by the storage capacity of the HD).

- Your choice of exam also defines the type of image processing possible during acquisition:
 - Recursive filter to reduce noise caused by movement,
 - Dynamic control of the image contrast (DRC),
 - Edge smoothing or sharpening.

If necessary, you can change the programmed processing for the exam during the study, as already described in the *previous paragraph* 2.3.3.

Note: Any such changes are only valid for the current exam. On changing the exam type or opening a new study, the default processing settings are restored to those set originally.

2.3.5 DIGITAL RADIOGRAPHY

This mode lets you acquire a single 'low noise' image in RADIOGRAPHY mode.

- **All radiography images are automatically saved to hard disk.**

The exposure parameters are automatically set by the equipment:

- The kV value will be identical to the one of the preceding fluoroscopy,
 - The mAs value will be automatically set by the equipment according to the exposure dose value preset for the exam. **If necessary, you still have the possibility to change the mAs values manually.**
 - The X-ray collimator remains as open as it was during the preceding fluoroscopy.
- The Digital Radiography mode is selected as follows:
 - By pressing on the **One Shot** symbol displayed on Control Panel,
 - Or automatically, if it has been set for the selected exam, pressing the right pedal or the two-stage function button on the handswitch.

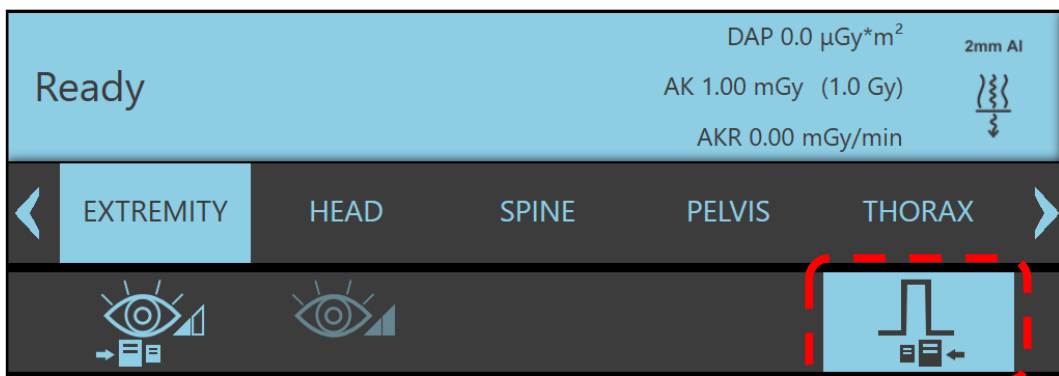

Change the exposure parameters as appropriate.

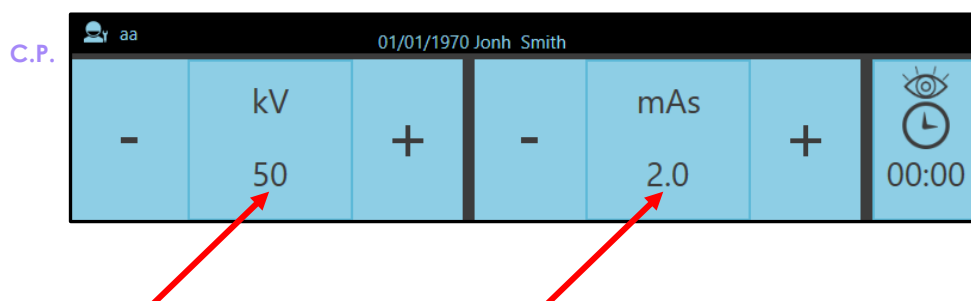

- The position of the collimator is the same as that used for fluoroscopy. This lets you expose only the anatomical part previously shown.

If necessary, you can open the shutters completely by touching this key on the Control Panel.



X-ray emission starts when the button or the footswitch are pressed:

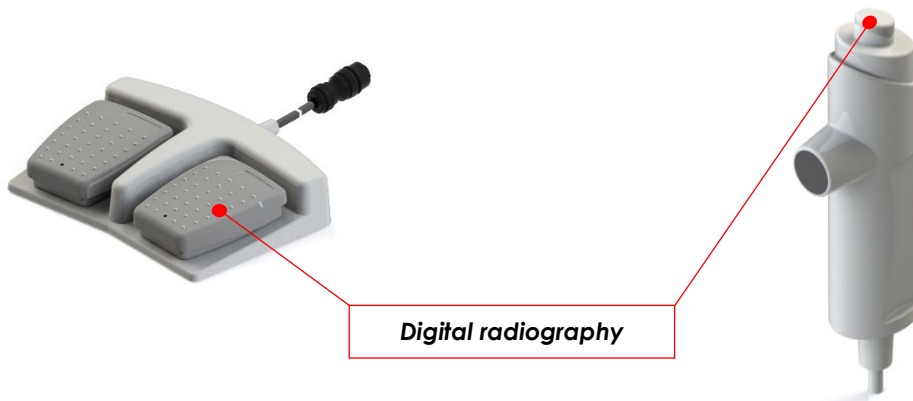

Always use the full length of the extensible handswitch cable (or footswitch cable) in order to stand as far away as possible from the irradiated zone.

- Pressing the first stage on the button, the equipment prepares for radiography. The Control Panel will display the messages: **RAD PREPARATION** and, after the preparation, **READY FOR RAD**.
- Press down the second stage of the button for actual X-ray emission. The control panel now displays **RAD EXPOSURE**.
- When using the footswitch, however, the **RAD PREPARATION** and **RAD EXPOSURE** phases are carried out simultaneously with a single pressure on the right footswitch.

Keep button (or footswitch) pressed until the exposure is over; a sequence of three beeps advises the exposure ends.

The **Control Panel** displays:

- The acquired image,
- The kV and mAs values,
- The heat units available in % and the monoblock temperature,
- The total dose* area value of the study (**DAP**),
- The total Air-Kerma of the study (**Air Kerma**),
- The **Air Kerma Rate**,
- The exposure indices (**EIt, EI, DI**).



There is a constant acoustic alarm and corresponding alarm message if there is an alarm or if you release the X-ray command button too early, thus interrupting exposure.



Exposure is inhibited when the available heat units fall below the level required for the set exposure. The equipment warns you of this with the **X-RAY TUBE THERMAL SAFETY** alarm.

The **Live Area** of the **Monitor** displays the following:

1. The acquired image,
2. The **kV** and **mAs** values and the exposure time in **ms**
3. The dose data of the study, indicated in the following order:
 - The total dose * area value of the study (**DAP**)
 - The total Air-Kerma of the study (**Air Kerma**)
 - The **Air Kerma Rate**
 - The actual X-ray emission time
 - the exposure indices (**EIt, EI, DI**)..

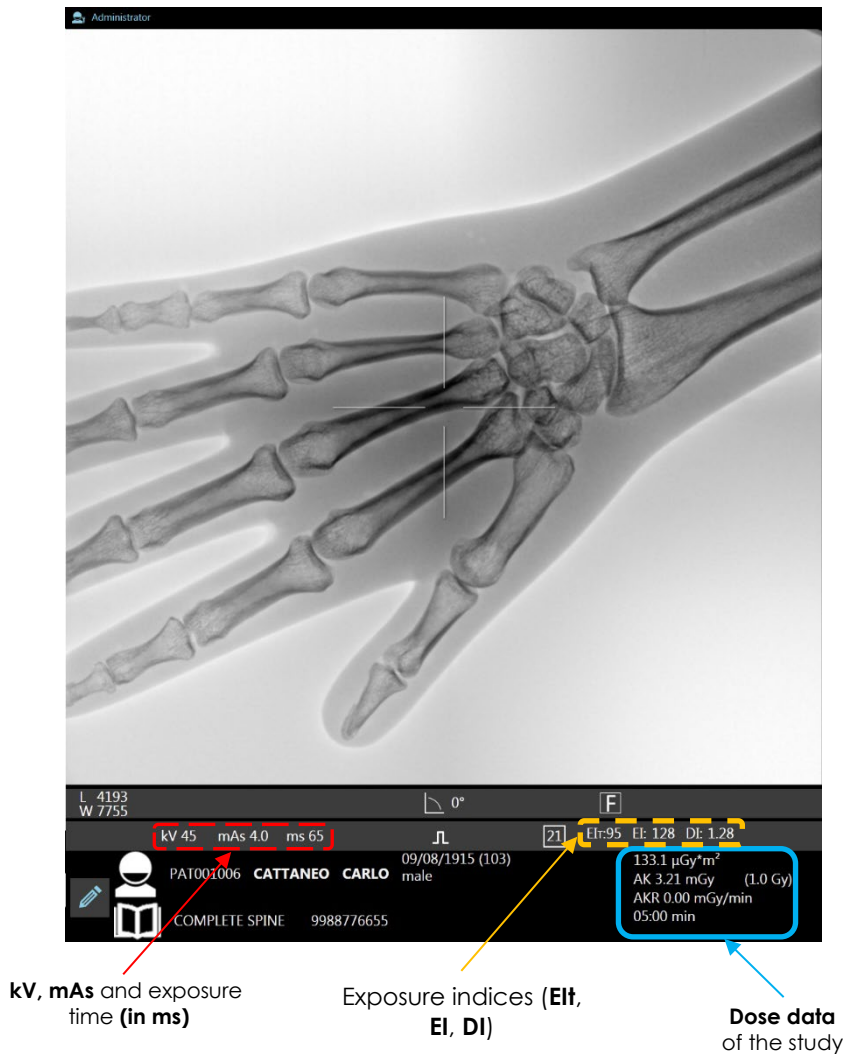

In compliance with standard EN 62494-1:2008, the following values are also shown, providing evidence of the exposure dose at the relevant exam values:

EIt:95 EI:87 DI: -0.39

- the **expected EXPOSURE INDEX (EIt)**, indicating the expected dose (EI value) for the exam.
- the **detected EXPOSURE INDEX (EI)**, measuring the response of the detector in the pertinent area of the image.
- the **DEVIATION INDEX (DI)**, which quantifies the deviation of the EXPOSURE INDEX from the optimal value of the dose set for the exam in question.

Note: These indices are displayed in different colors, according to the exposure dose measured. If the image is overexposed, the indices will be displayed in red, while an underexposed image will be displayed with blue indices; the indices will be displayed in white if the image is correctly exposed.

The table below provides an example of a difference in the **EIt**, **EI** and the **DI** after several exposures, with the dose set at 1 μ Gy:

set target Dose (μ Gy)	EIt	Dose detected by detector (μ Gy)	EI	DI
1	100	2.6	260	4.0
1	100	2.0	200	3.0
1	100	1.6	160	2.0
1	100	1.25	125	1.0
1	100	1.00	100	0.0
1	100	0.8	80	-1.0
1	100	0.6	60	-2.0
1	100	0.5	50	-3.0
1	100	0.4	40	-4.0

- At the end of the X-ray emission, the image is automatically saved to the hard disk and is displayed on the Monitor. The thumbnail of the image just saved to the HD is added to the list of images.

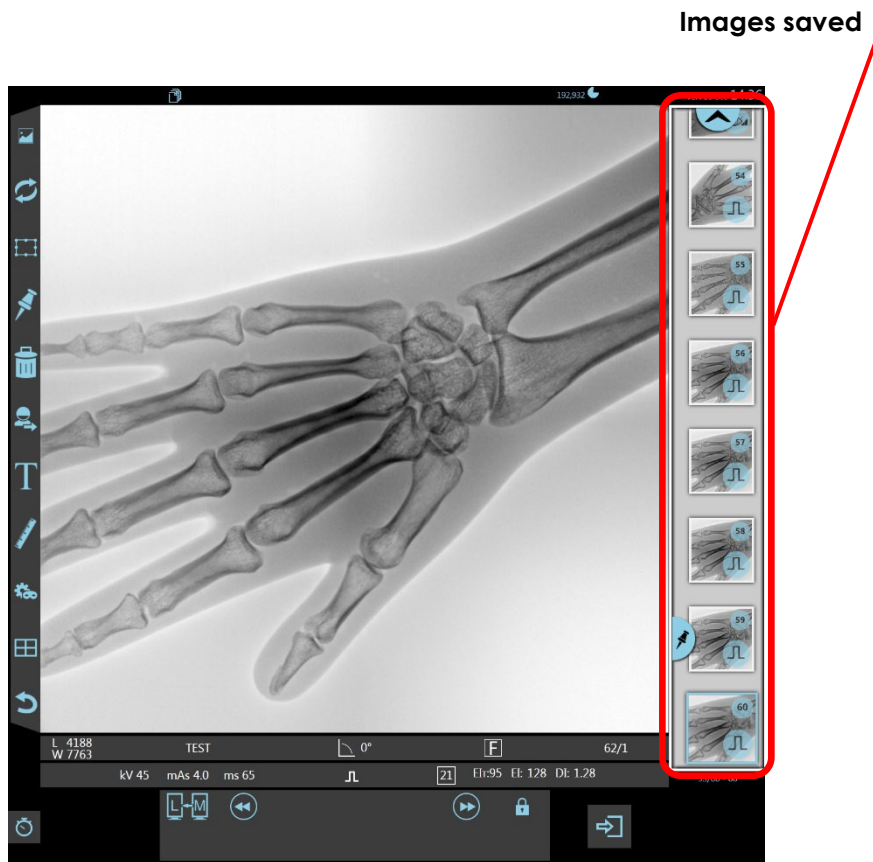

2.3.6 X-RAY TIMER

- The Control Panel indicates the overall time you press the X-ray emission command (button or footswitch) in minutes and seconds.

C.P.



- There is an acoustic warning after every 5 minutes of X-ray emission (a continuous beep) and a bell warning appears on the screen.
- Reset the alarm by touching the alarm bell **icon**. This alarm starts 30 seconds before the 5 minutes are up. X-ray emission is stopped if you fail to reset the alarm within 30 seconds.
- You can reset the accumulated X-ray emission timer at any time by touching the **timer** (for at least 3 seconds).



X-ray emission is stopped in any case whenever the X-ray command is constantly used for 10 minutes. You can only continue after releasing the X-ray command.
An acoustic warning sounds 30" before the 10 minutes are up, warning you that X-ray emission is about to be stopped.

2.3.7 HEAT UNIT COUNT

The equipment automatically counts the Heat Units:

- in the anode (**aHU**)
- in the monoblock (**mHU**).

The Control Panel displays the available Heat Unit values (%) for both the anode and monoblock:

C.P.

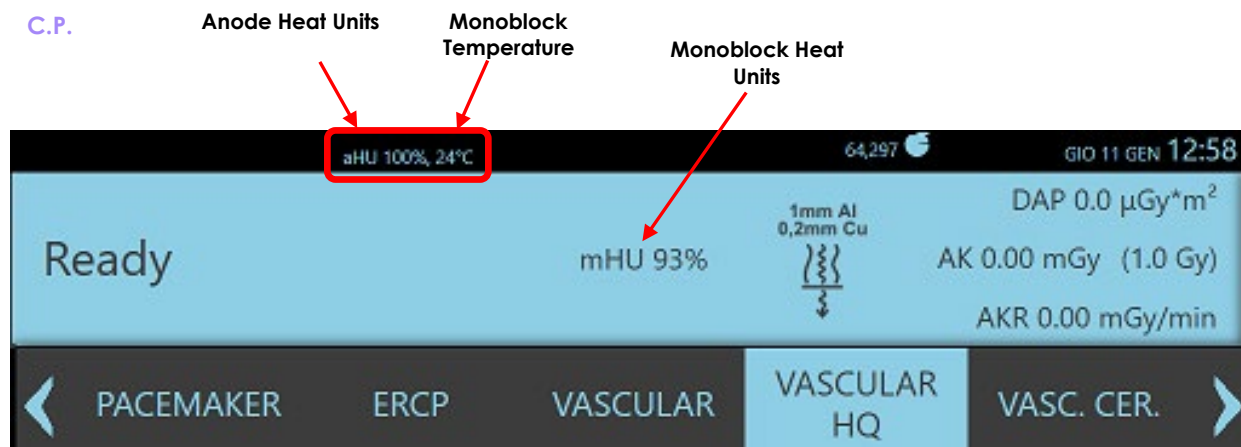

During the X-ray emission in Fluoroscopy, if the heat units of the **anode or the monoblock** fall below **10%**, the system will emit an intermittent acoustic alarm (double beep every 3 seconds).



Exposure can continue, but the **mA value is automatically reduced** to prevent the X-ray monoblock from overheating.

The mA value returns to normal when the available Heat Units are again **higher than 15% for the monoblock** and **higher than 20% for the anode**.

Exposure is inhibited when the available heat units fall below the level required for the set exposure in radiography mode. The **X-RAY TUBE TOO HOT** alarm is generated if you use the X-ray command.

Note: *If the percentage of the remaining heat units is too low and if no further images have to be acquired, it is recommended to turn off the system for a faster cooldown of the X-ray generator; a stand which has been turned off needs approximately one and a half hours to change from mHU= 5% to mHU=55%.*

2.3.8 FLAT PANEL DETECTOR ZOOM FIELDS

Depending on the FPD chosen, these are the available fields:

FPD 21 x 21

21 x 21 cm², 16 x 16 cm² e 12 x 12cm²

FPD 30 x 30

30 x 30 cm², 21 x 21 cm² e 16 x 16cm²

- In fluoroscopy, the working field can be selected among the 3 sizes displayed on the Control Panel
- In digital radiography, however, the largest field is set and used automatically.

C.P.

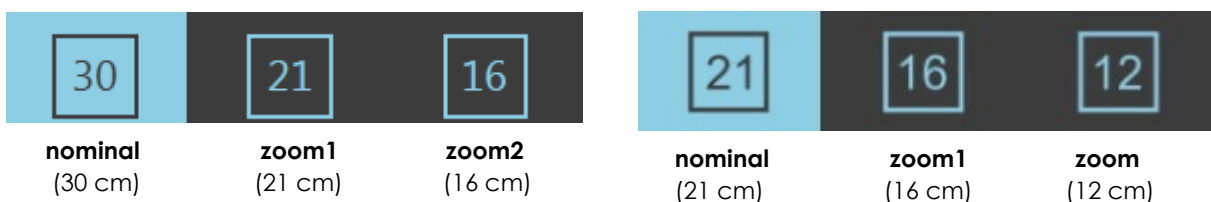





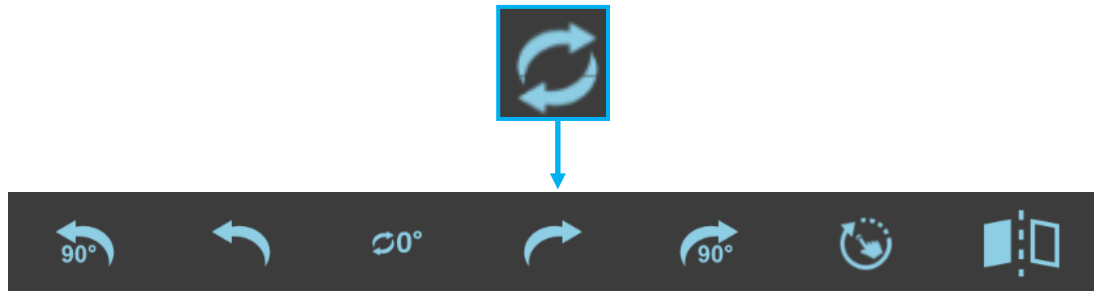

2.3.9 IMAGE ROTATION / FLIP

During image acquisition, you can change the orientation of the image by using the rotation and horizontal flip commands. Access these commands by touching the key shown in the figure below, thus opening the relevant menu:





• **Rotation:**

	90° image rotation (counter-clockwise)
	Counter-clockwise rotation of the image (in 1° steps)
	Image rotation reset
	Image rotation clockwise (in steps of 1°)
	90° image rotation (clockwise)
	Free rotation of the image.



You can also activate the rotation function on the LIH image. The orientation will be valid for the subsequent acquisition, meaning you can adjust the image orientation without X-ray emission.

• **Horizontal image flip:**

OFF	ON	
		Horizontal image flip

The horizontal flip can be used for both the LIVE image and the LIH image.

2.3.10 X-RAY COLLIMATOR

The collimator has a squared diaphragm and a diaphragm with parallel, rotating shutters: the latter ones can even be opened independently from one another (**asymmetric collimation**). The opening is controlled via the Control Panel:

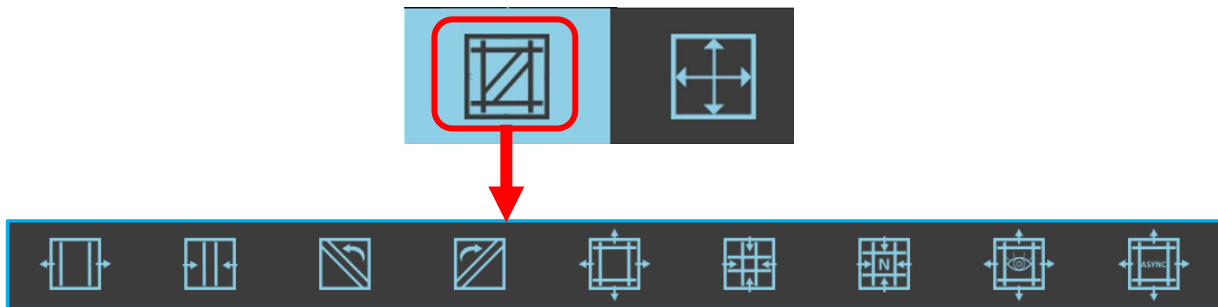

The keys for the collimator operation can be found in a single menu which is opened by pressing the corresponding key on the Control Panel (see picture above).

		Open/close shutters
		Rotate shutters (clockwise / counter-clockwise)
		Open/close square iris
		This key is meant to open the collimator squared iris to the default value that has been set in Exam Setup menu (See Paragraph 4.4.1, Part 2 of the Technical Manual).
		Show or hide the symbols for adjusting the collimator opening directly on the image on the Control Panel.
		Enable the options for asymmetric adjustment of the parallel shutters.
		Opens completely the squared diaphragm and shutters with a single touch



The max square aperture of the squared iris is automatically determined to suit the selected detector zoom field.

Make sure that the edges of the square iris are visible on the image during exposure (e.g. during fluoroscopy).

2.3.10.1 VIRTUAL COLLIMATOR DISPLAY

This function lets you position the square iris and the shutters on a particular part of the saved image without any X-ray emission (thus minimizing exposure for the patient and operator). The virtual collimator is displayed over the LIH image.

To view the virtual collimator, use one of the following commands in the absence of X-ray emission:

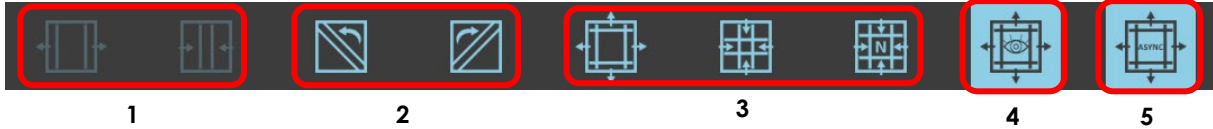

- 1 Open/close shutters
- 2 Rotate shutters
- 3 Open / close / reset to default values of the square field
- 4 Show or hide the symbols for adjusting the collimator opening directly on the image on the Control Panel.
- 5 Enable the options for asymmetric opening of the shutters.

On releasing this command, the virtual indicator disappears after 60 seconds.

Examples:

Assuming we have the LIH image here, you can use the following commands:

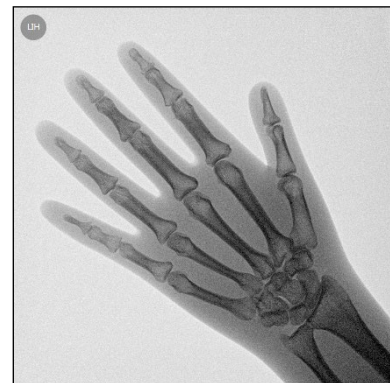

• **Square iris**

If you want to collimate the center of the image, close the squared iris:

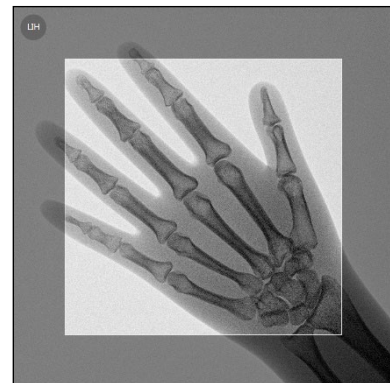

On giving the X-ray command, you get this result:



- **Shutters**

If you close the shutters:



On giving the X-ray command, you get this result:

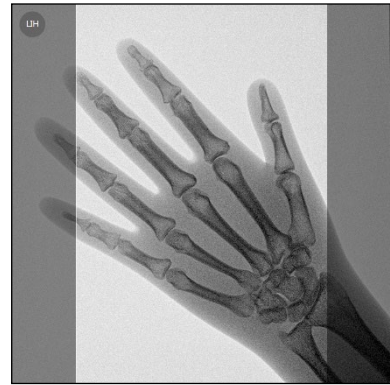

If you rotate the shutters:



On giving the X-ray command, you get this result:



When pressing the symbol shown next to this text, the keys for controlling the collimator directly on the LIH will be displayed.

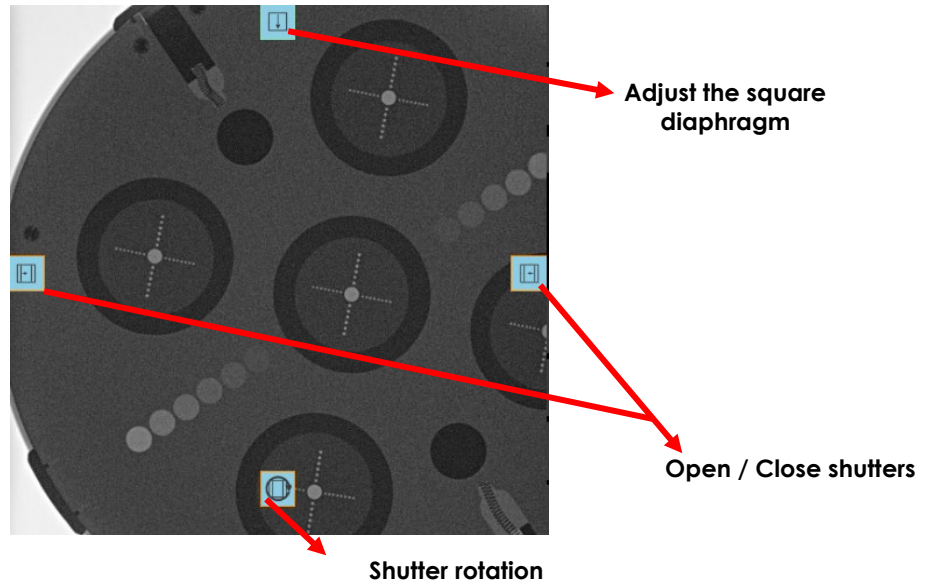

By pressing the symbol shown next to this text, you will enable the possibility to control the opening of both shutters independently from one another. The following picture shows an example:

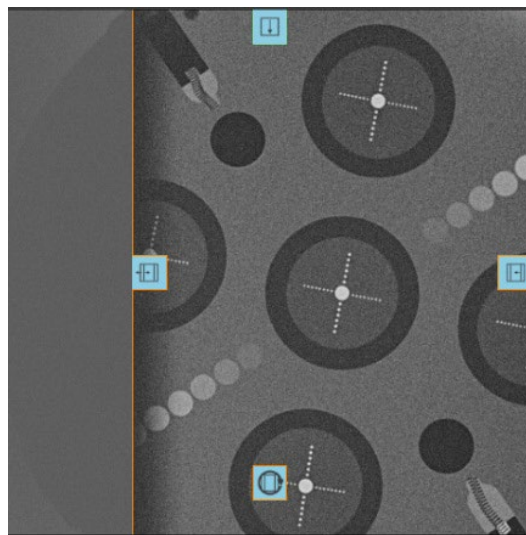

Note: It is possible to change the appearance of the virtual indication of the collimator position, selecting one of two options: **transparent** or **black**. See Paragraph 4.2, Part 2 of the Technical Manual for further details.

2.3.11 STOPWATCH FUNCTION



The EM device is equipped with a timing function which can be accessed either via the **Control Panel** or the **Monitor**. This function is useful whenever you need to measure the duration of specific procedures. To activate the function, just press the corresponding key which can be found on the lower part of the **Monitor**:

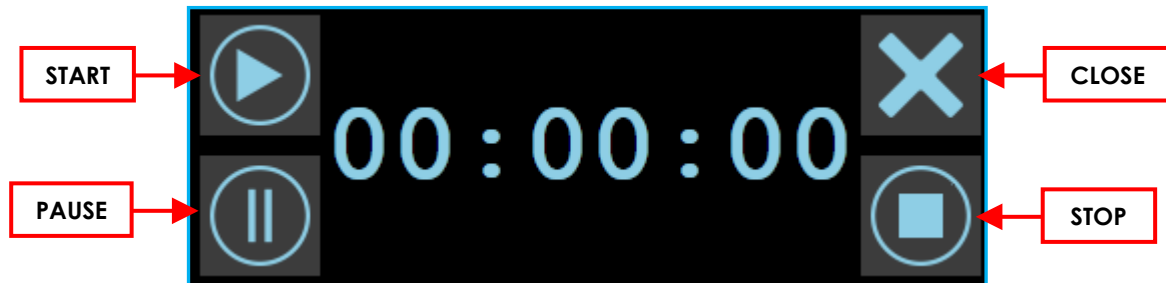

This function can also be activated on the **Control Panel**. The command keys are the same as those described above. The function will be disabled by pressing once again the activation key or when the next X-ray command is given.

Note: To enable the function see Paragraph 4.4.1, Section 2 of the Technical Manual.

2.3.12 SIGHT FUNCTION

The equipment lets you enable a function to display a sight (globe sight or cross-hair) in the center of the image.

When opening an exam (if enabled during the installation of the equipment), the sight will be shown on the **Control Panel** and in the **Live Area** of the **Monitor**.

Two different sight forms are available: **Cross-hair** or **Globe sight**.

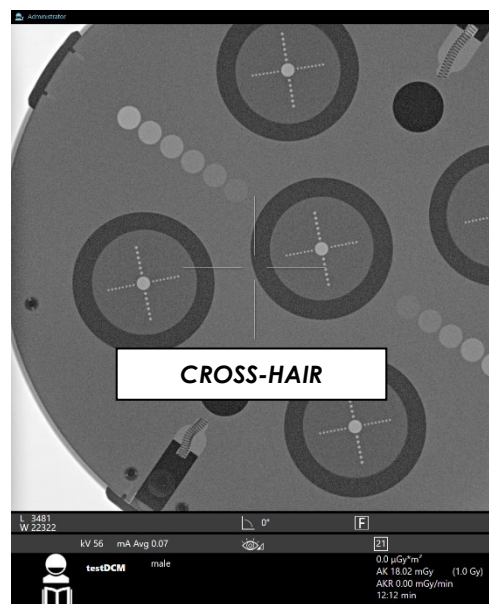
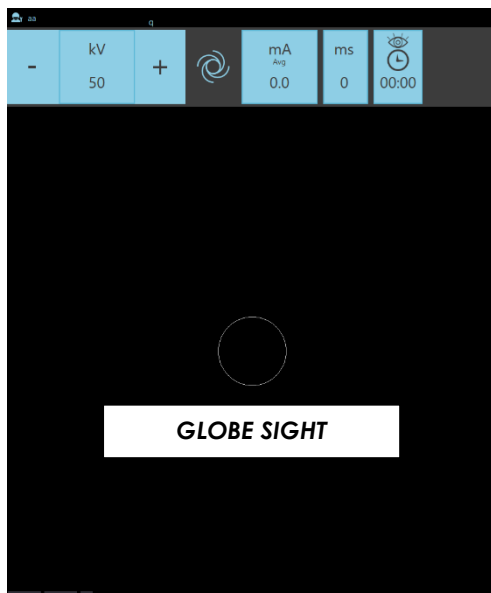

You can suspend the view directly from the **Control Panel**, by pressing the symbol next to here:



Note: see paragraph 4.4.1, Part 2 of the Technical Manual for the settings of the sight function; if you set the value None, no sight will be displayed.

2.3.13 REFERENCE IMAGE

During the image acquisition, the **Memory area** of the **Monitor** displays a previously saved image (**Reference Image**), so that it can be compared to the images which are displayed in the **Live area**.

There are two alternative operating modes:

- a) At the beginning of each new acquisition, the previously saved **LIH image** will be shown as a reference image.
 - b) Alternatively, it is possible to choose a reference image from those acquired in the study by selecting it from the thumbnails and confirming this choice by pressing the **Reference Image** key.
- This reference image remains fixed for every new acquisition until the choice is cancelled by pressing once again on the **Reference Image** key.

In that case, it will return automatically to the previous operating mode (see **item a**).

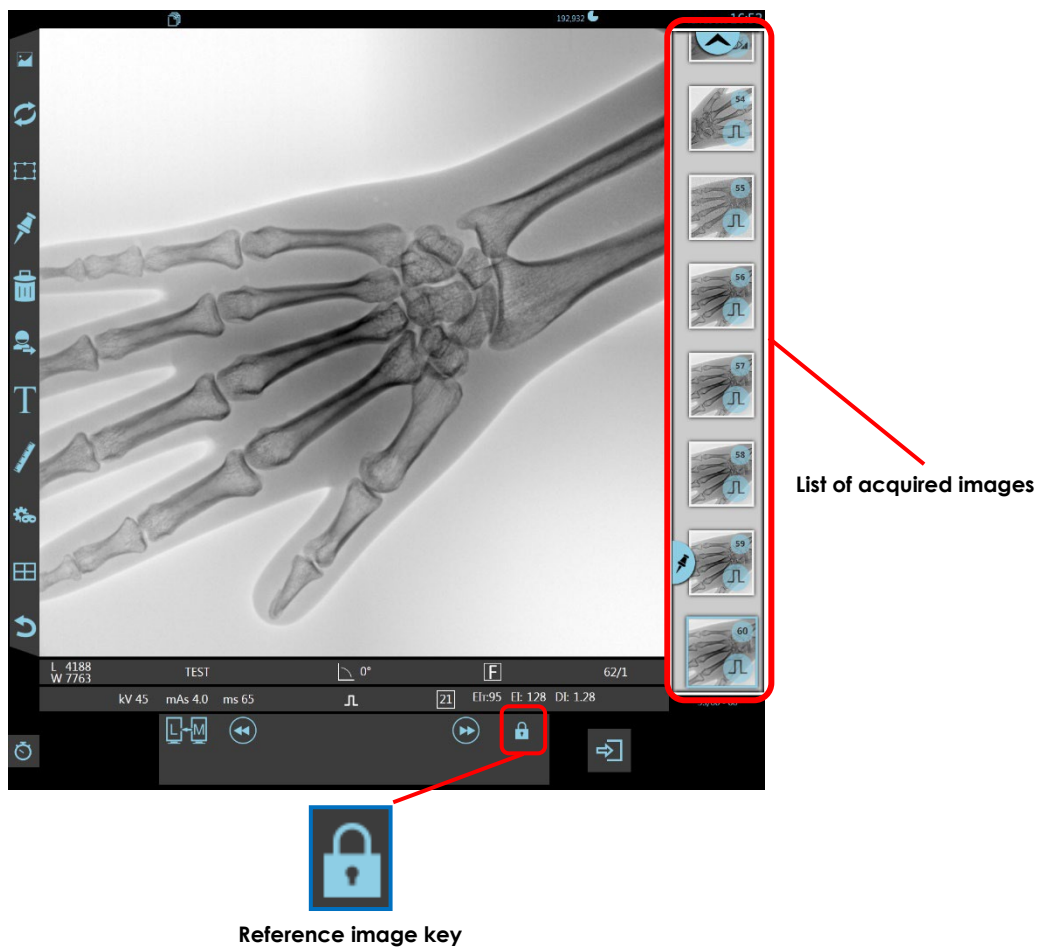

Note: when the Reference Image function is enabled, the reference image cannot be deleted.

2.4 FINDING AND VIEWING IMAGES

2.4.1 FINDING IMAGES

- In the **Study List** frame of either the **Control Panel** or the **Monitor**, you can use the thumbnail function to visualize the images in the study; this function makes it easier to select the studies of interest:

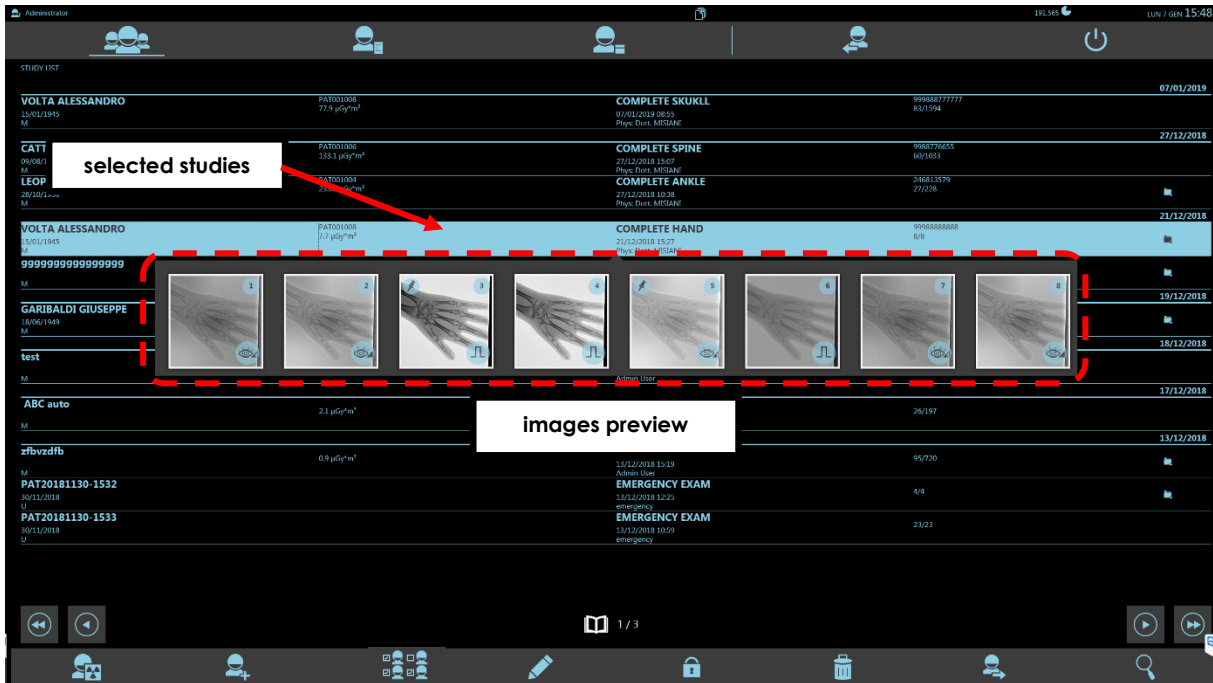

- The images are grouped in "runs", which correspond to each X-ray emission.
- A run can consist of a single image or a series of images (multiframe run):

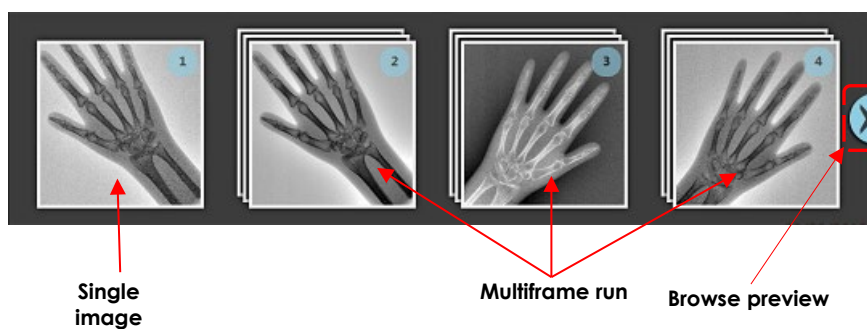

- Browse the preview images to scroll all the runs in the study. Tapping twice on the preview image, will open the study and display the first image of the selected run on the memory area of the monitor.

2.4.1.1 SINGLE IMAGE

If the preview image relates to a run containing just a **single image**, the screen will look like this:

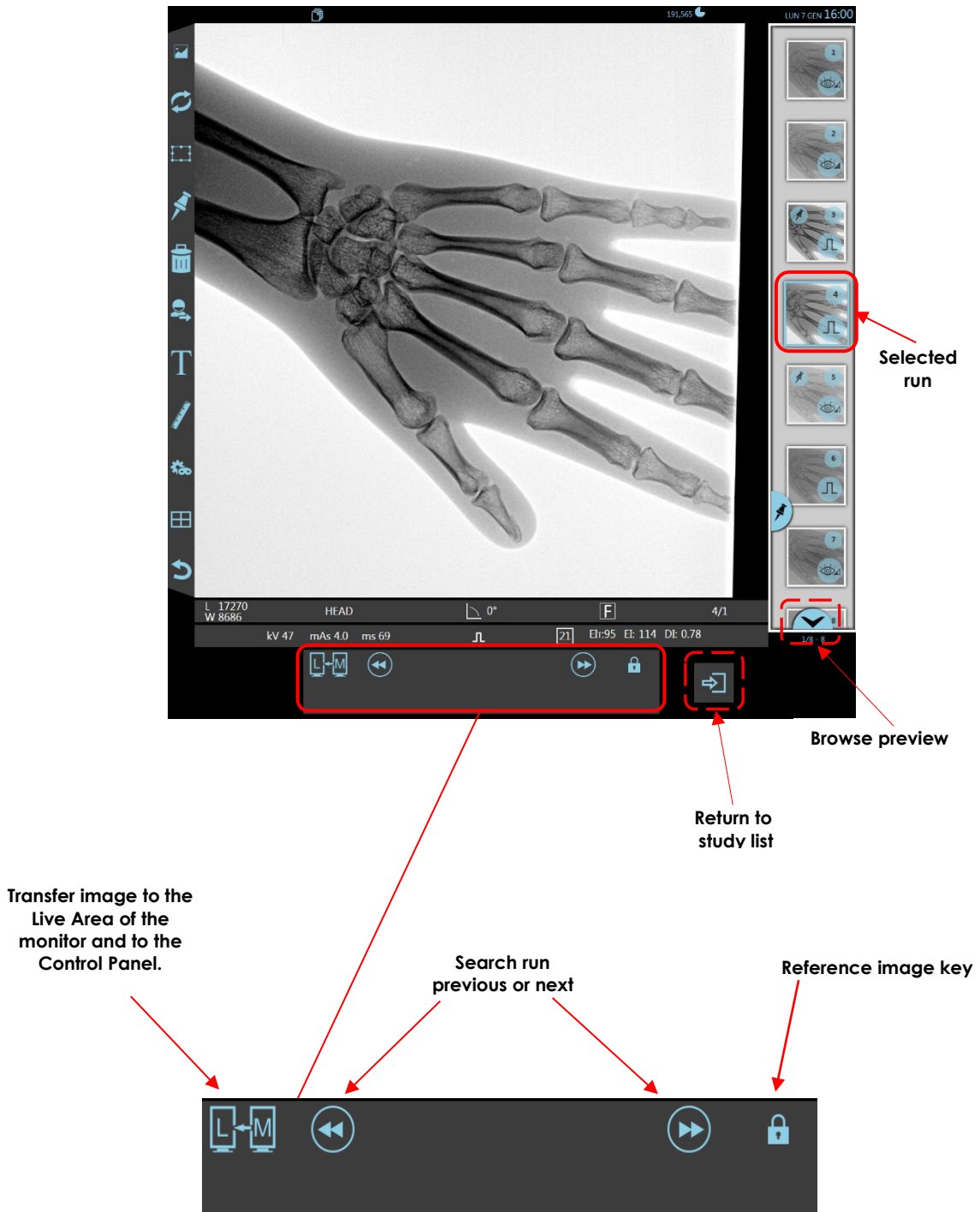

2.4.1.2 MULTIFRAME RUN

If the preview image relates to a run containing a **series of images** (multiframe run), the screen will look like this:

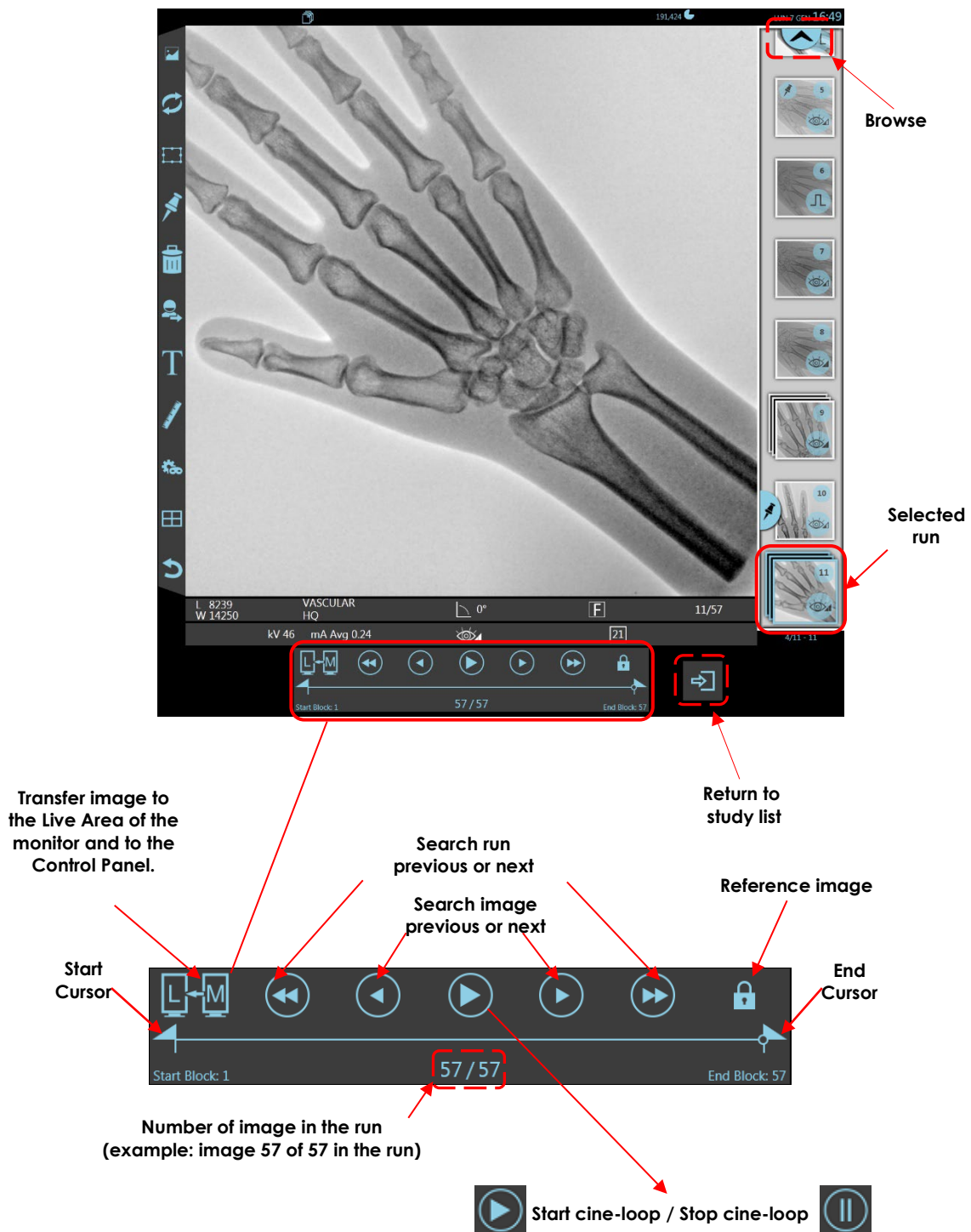

In addition to the keys letting you find the previous or next run and transfer it there are also:

- keys letting you find a single image in the run,
- the start/stop cine-loop key that lets you view all the images in the run of a dynamic loop (presentation mode).

- The **Cursors** are used to limit the scenes of images to be reproduced by the cine-loop. Move the **Start Cursor** in order to start the reproduction from an image other than the first one; move the **Stop Cursor** in order to end the reproduction at an image before the last acquired one. The image numbers of the first and last image of the scene are displayed under the start and the end of the progression bar.

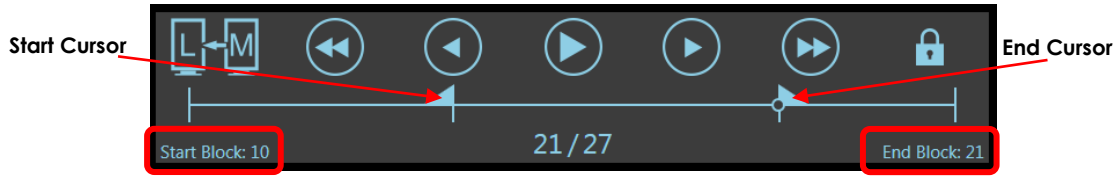

- The **Reference image** key stops the cine-loop at that image, thus disabling the other keys at the same time; press the key once again to end the function.

2.4.2 VIEWING MULTIPLE IMAGES

The **memory area** of the Monitor lets you view the images in OVERVIEW mode when pressing the relevant key. You can choose between **5 views**:

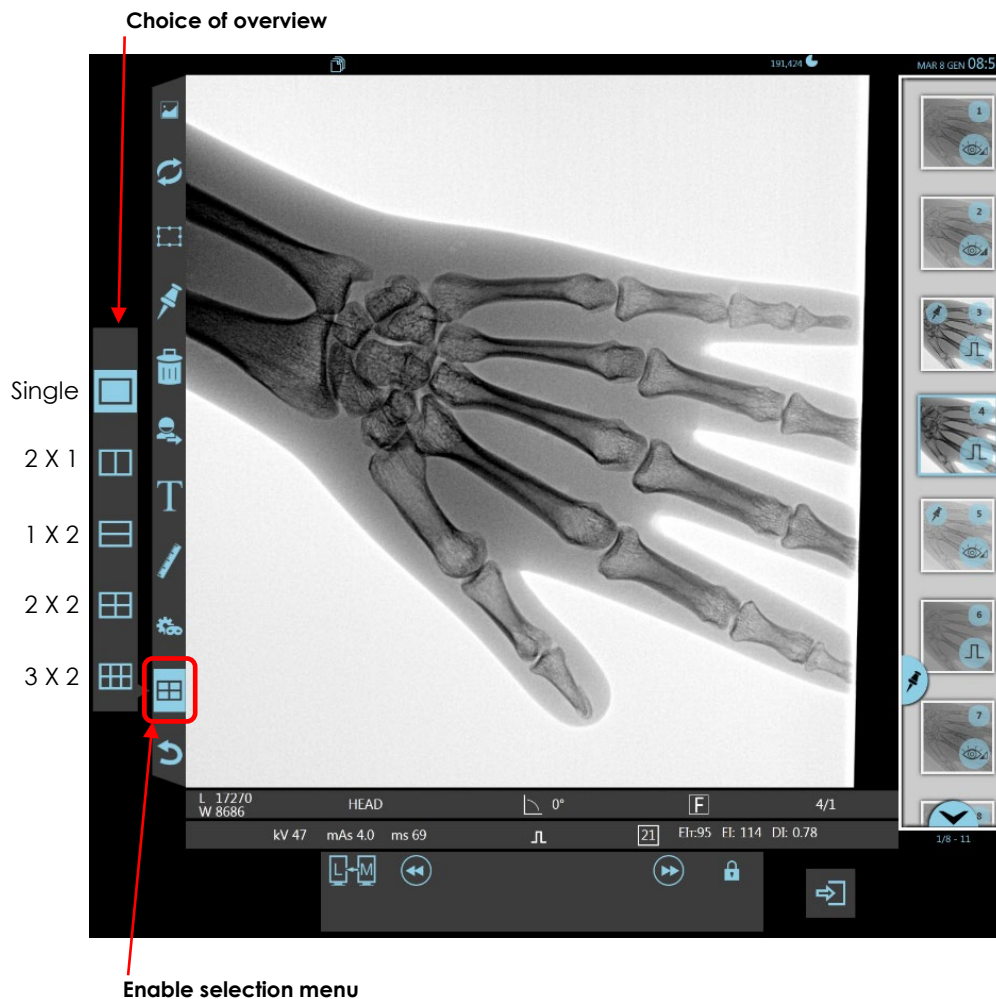

For example, if you select format 2x2, the screen will look like that below.

To load the runs into the overview boxes, just drag the thumbnail of the image with your finger into the box you wish.

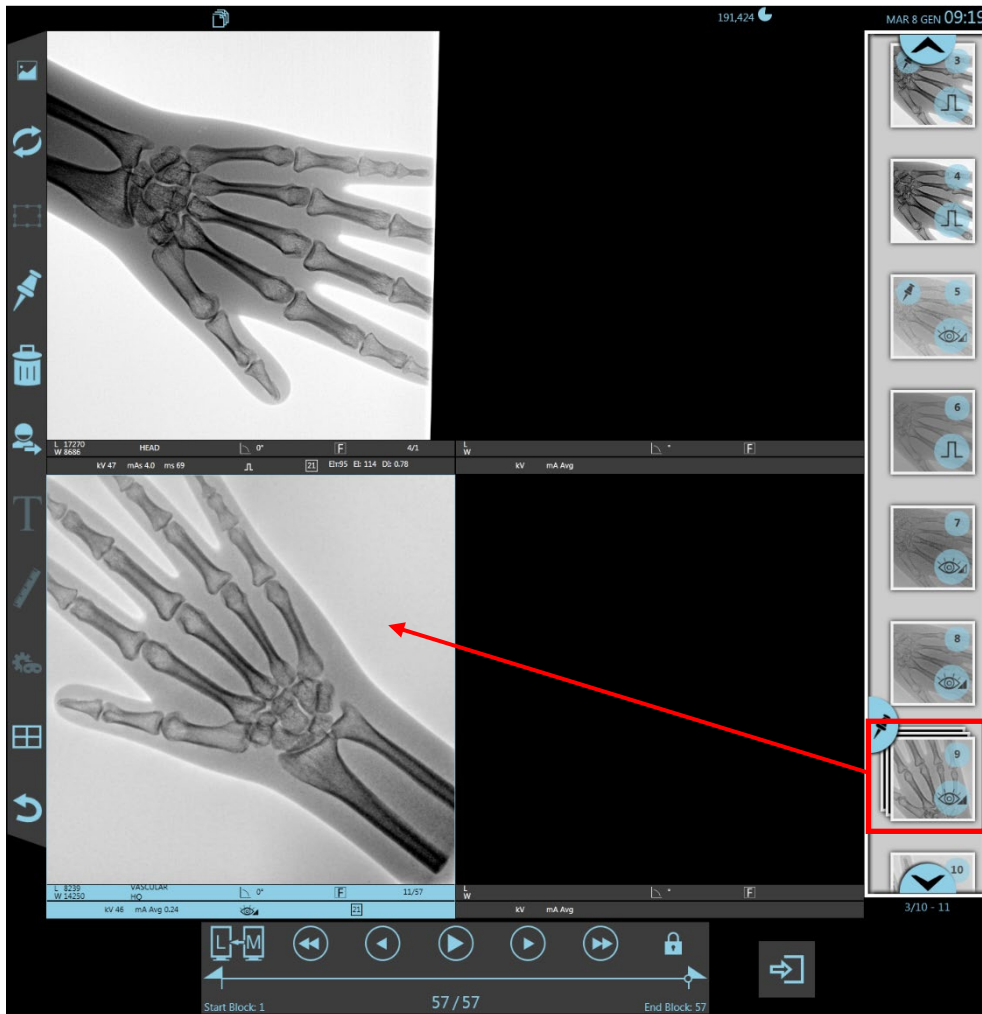

The same interface as described above for a single image applies to each overview box; for each run it is thus possible to carry out the same operations as per above *paragraph 2.4.1*.

Note: even in multi-image boxes, you can adjust the values of W and L using the dedicated gesture.

3 POST-PROCESSING OF IMAGES

3.1 INTRODUCTION

Images saved to hard disk can be processed via the Monitor Memory Area:

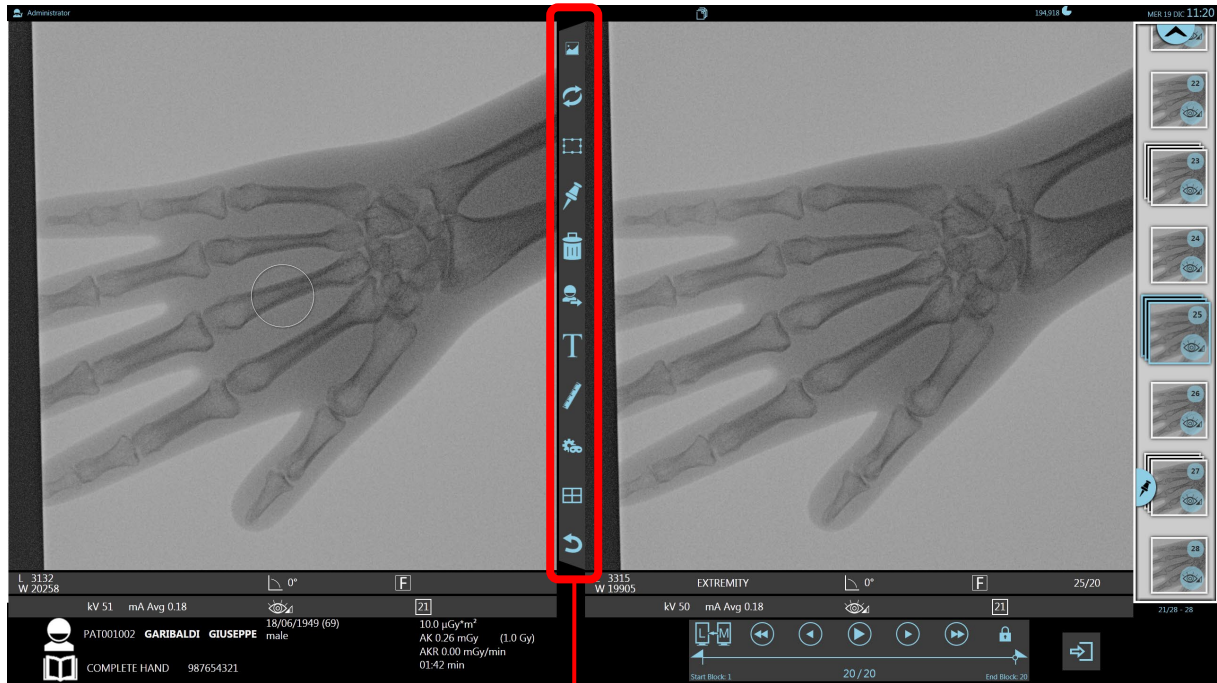

Post processing functions

Note: The 'Find image', 'Overview' and 'Cine-loop' functions have already been described in paragraph 2.4, Part 2 of this manual

3.1.1 ACQUIRED IMAGE DETAILS

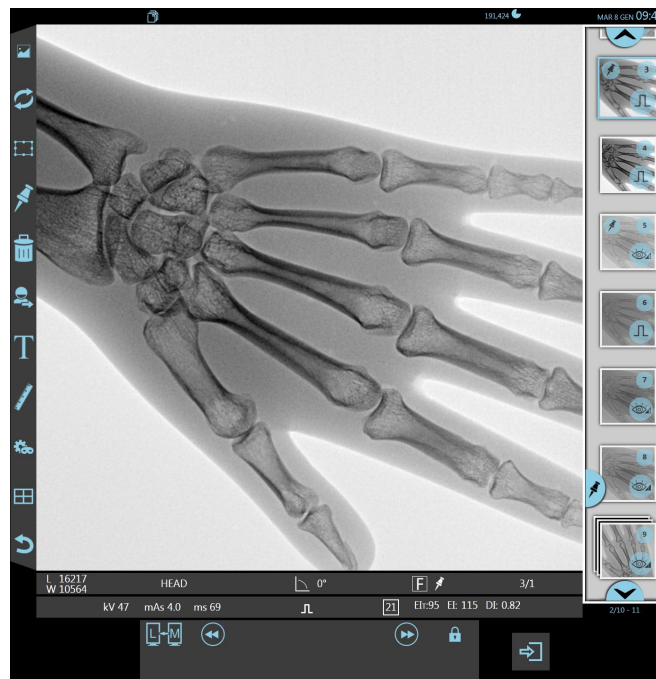

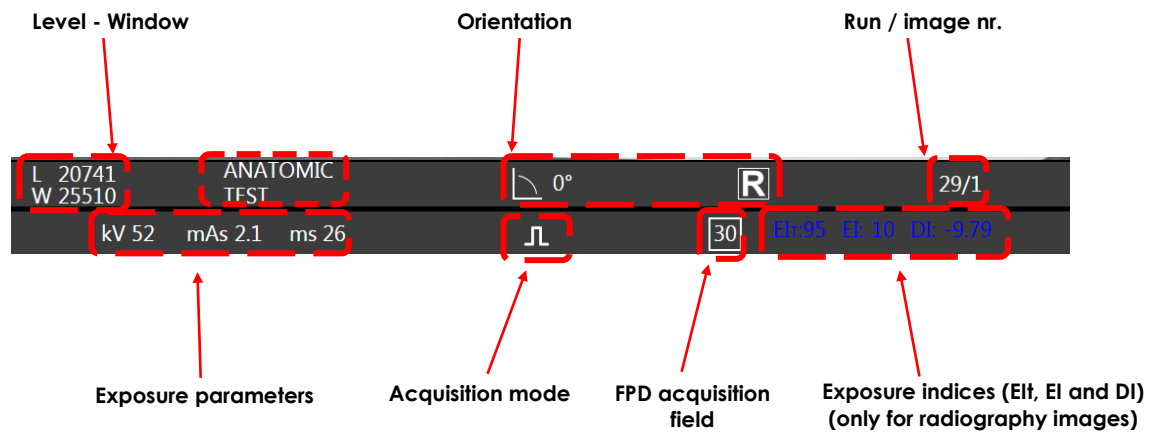

3.1.2 LIVE DRAWING FUNCTION

The **Live Drawing** function can be used on both **monitors**; this function allows you to draw temporary lines on the image (LIH). You can also select the thickness and the color of the line.



These lines will remain in the place they were drawn even for the following acquisitions. They can thus be used as points of reference during the intervention.

Press the corresponding key and the following menu will appear:

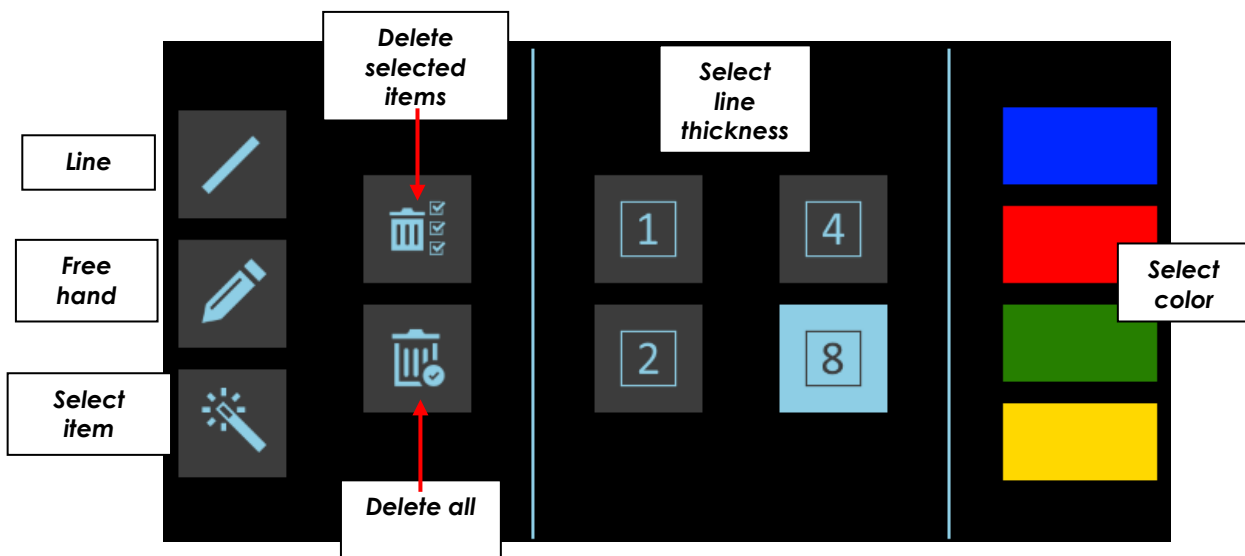

Once you have selected the line type, the thickness and the color, you can start drawing on the image. Use the corresponding key to delete the drawing (**Delete all**); in case there is more than one drawing, and if you do not wish to delete them all, you can press the **Select item** key, then select those you wish to delete (the selected image will appear in a dashed line) and use then the key **Delete selected items**.

When changing to another exam or when closing the study, the drawings will be deleted automatically (the drawings are not saved with the image). To exit this function, press the relevant key again.

Note: To enable the function see Paragraph 4.4.1, Section 2 of the Technical Manual.

3.2 IMAGE PROCESSING



Touch the key shown here to open the IMAGE PROCESSING menu:



This menu offers these options:

- **Adjust the W and L**

You can change the look of saved images by adjusting the contrast (Window - W) and brightness (Level - L) either automatically or manually:



In automatic mode, the EM equipment sets the W and L values to suit the contents of the image.



In manual mode, you can change the W and L values by swiping your finger across the image:

- swipe horizontally to change the W value.
- swipe vertically to change the L value.

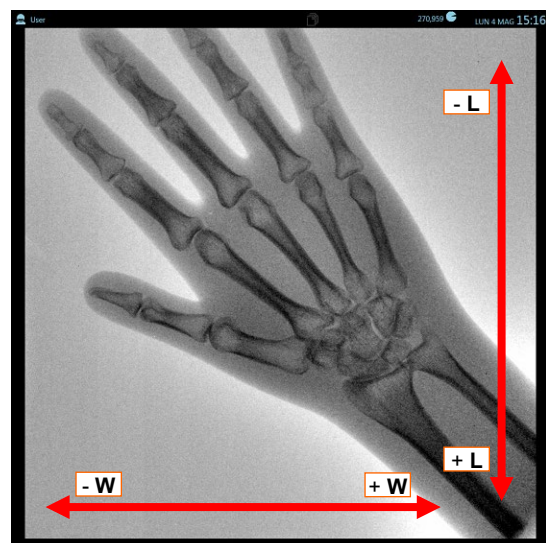

• **Grey scale inversion**

Select this key to invert the grey scale (negative or positive presentation):

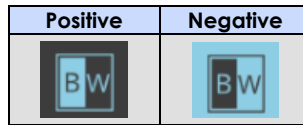

• **Select spatial filters**

Each exam type can use one of two set spatial filters: SHARP (to enhance the edges) and SMOOTH (to soften the edges).

Touch NONE for no filter.



• **Select DRC**

Each exam type can use one of three image dynamics and contrast control processes (**DRC, dynamic range compression**). These three processes are programmed during installation to suit the type of exam.



• **Noise Reduction factor**

This function allows to reduce possible noise on the image by increasing the value of this factor; the **range** goes from **0** to **10**.

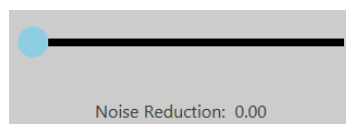

• **Zoom Pan**

Once enabled, this function allows the increase or decrease of the image zoom factor by pressing the dedicated keys and lets you move the image in order to view only the part of major interest.

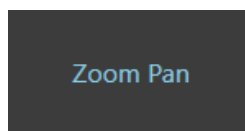

Note: furthermore, it is possible to enlarge the image shown on the Memory area of the monitor with **gestures**, without having to enable the Zoom Pan function.

3.3 IMAGE ORIENTATION

Touch the key shown here to open the IMAGE ORIENTATION menu:



This menu offers these options:

	90° image rotation (counter-clockwise)
	Counter-clockwise image rotation (in steps of 1°)
	Image rotation reset
	Clockwise image rotation (steps of 1°)
	90° image rotation (clockwise)
	Allows to freely rotate the image.
OFF	ON
Horizontal image flip	

Example:

The image is rotated 30° clockwise and then flipped horizontally.



3.4 ELECTRONIC SHUTTERS

Electronic shutters let you cover parts of a saved image.



To use this function, touch the key shown:

- Use your finger to draw a diagonal line across the rectangle you want to crop (all parts of the image outside this rectangle will be covered by a black background):



- After selecting the interested area, you can:

- Change its size by touching one of its sides and then moving this as required.

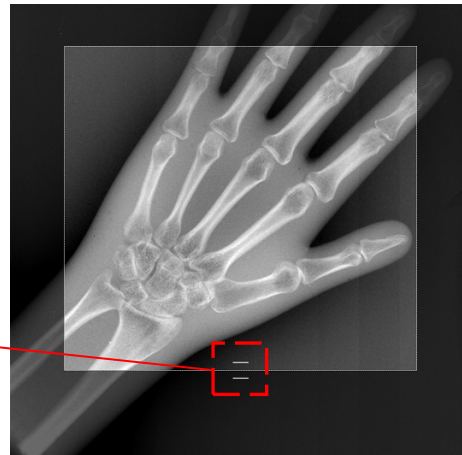
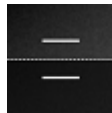

- Rotate it, by holding one of the corners and dragging it to the required position

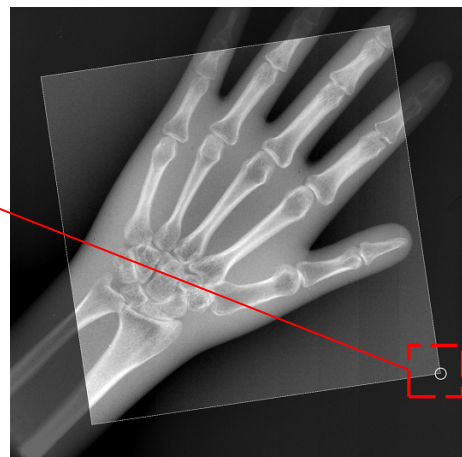

- Shift it, by touching one point inside the collimated area and dragging it to the required position

- Quit this function, confirming the cropped image, by touching this command again:



- You can then cancel the crop by touching this function again:

Note: You can only crop an image if the portion of the image you want to retain is at least 2 cm (approx.).

3.5 FLAGGING IMAGES

Saved images can be flagged (pinned) to facilitate the DICOM send operations (see Paragraph 6.5, Part 2).

In fact, the system checks whether there are any flagged images when you select these functions and displays them with a message so you can decide what to do.



Flag an image by touching this key:

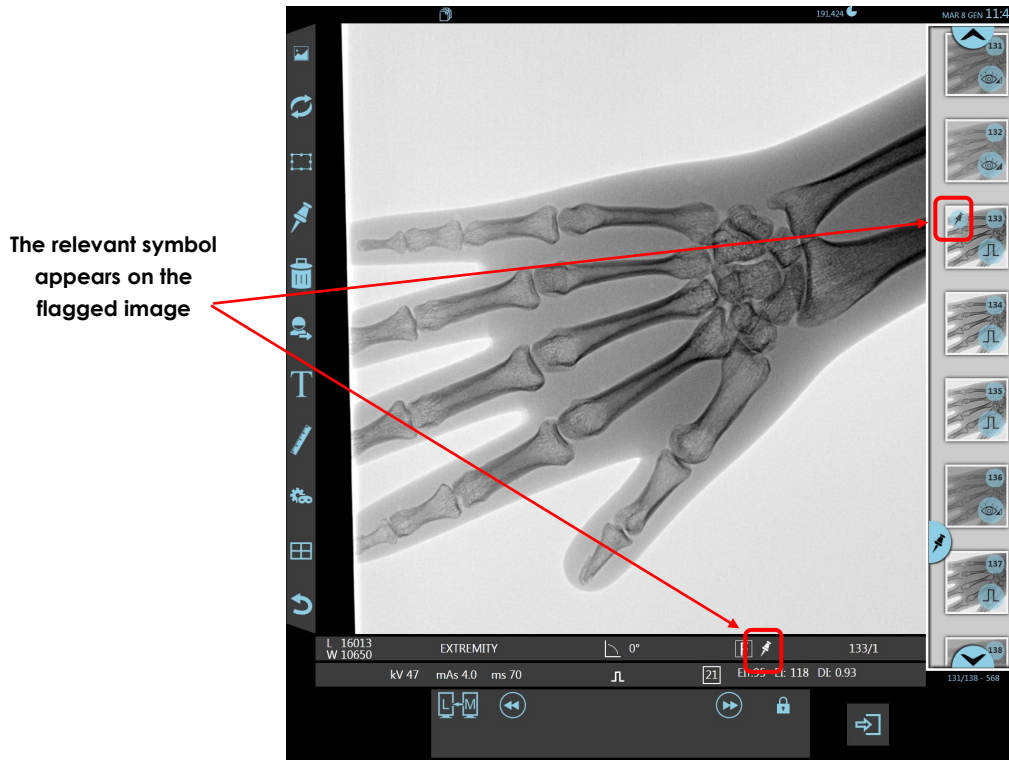

- The following window appears when you send pinned images to a DICOM server. This lets you choose the server you want to send the images to. Furthermore, you can choose to send:
 - all the images of the run containing the flagged image,
 - only the flagged images in the selected run,
 - the whole study,
 - all the flagged images within the study.

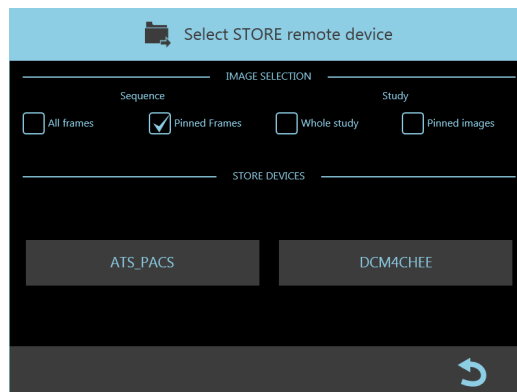

3.6 DELETING IMAGES



You can delete images on the screen by using this key:

You are asked to confirm deletion when you touch this key:

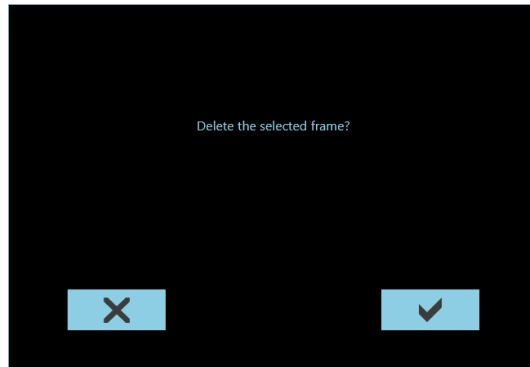

To cancel a single image

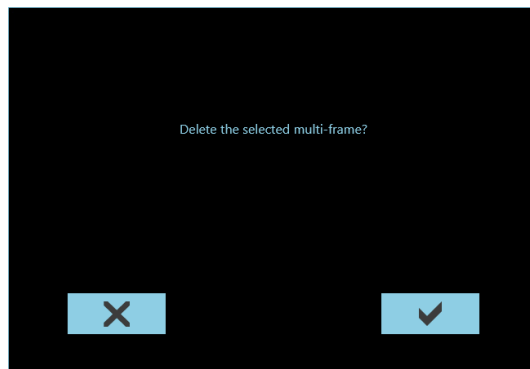

To cancel a multiframe run









You can also delete an entire **study** (see paragraph 6.4.3 in this part of the manual).

3.7 IMAGE RECORDS



Touch the key shown here to open the IMAGE RECORDS menu:

This menu offers these options:

	Send images to a DICOM node using the STORE DICOM function (see paragraph 6.5.1 in this part of the manual).
	Save images in DICOM format to a USB device. (see the annex to paragraph 6.6 in this part of the manual).
	Send images to a printer using the PRINT DICOM function (see the annex to paragraph 6.5.2 in this part of the manual).
	Send images to a local Windows compatible printer (see paragraph 3.7.1 below).
	Send RDSR file (information about irradiation dose given to the patient) to a remote storage device used to record the X-ray dose given to the patient.
	Display the RDSR file on of the dose given to the patient.
	Send images to USB Driver in DICOM for Processing format. The function is available for <i>Advanced</i> and <i>Administrator</i> users, only.
	Creation of the Dose Report Image , containing: the study data and information on the dose received by the patient during the exam (see Paragraph 3.7.2 below).

3.7.1 DIRECT PRINT-OUTS (OPTIONAL)

A single live image on the monitor can be sent to the local printer.

Select the corresponding command in the IMAGE RECORDS menu:

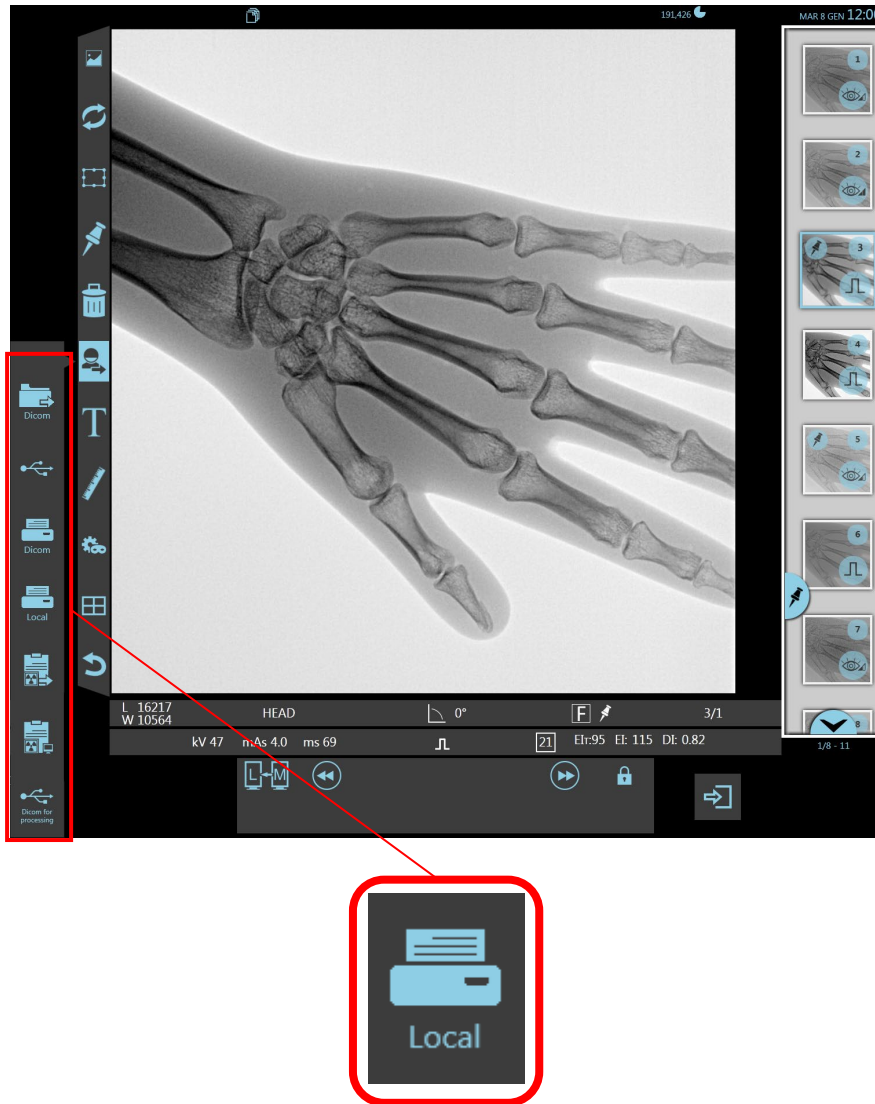

Wait for the image to be printed: do not keep pressing the key (thereby sending new copies of the same image to the print queue).

The EM equipment is provided with printer (as optional):

- **Sony Model UP-D898MD.**

Note: Printed images are **not** to be intended for clinical or diagnostic purposes.

3.7.2 DOSE REPORT IMAGE

Pressing the dedicated button, the operator creates the **Dose Report Image** of the study. This will be displayed as the last image among the preview icons, numbered as a normal image of the study.



Patient and Study Data			
Patient Name:	Alighieri^Dante	Institution Name:	HOSPITAL
Patient ID:		Physician's Name:	Admin User
Patient's Birthdate:	1601/01/01	Exam type:	Chest, Abdomen,
Patient's Sex:	M	Study Date and Time:	2019/10/21 15:35:38
Accession Number:			
Total Accumulated X-Ray Dose Data			
Total Number of Radiographic Frames:	151		
Dose Area Product Total	0.4046000 mGy*m ²		
Dose(RP) Total	8.872000 mGy		
Fluoro Accumulated X-Ray Dose Data			
Fluoro Dose Area Product Total:	0.3707000 mGy*m ²		
Fluoro Dose(RP) Total:	8.094000 mGy		
Total Fluoro Time:	00:23 s		
Acquisition Accumulated X-Ray Dose Data			
Acquisition Dose Area Product Total:	0.0339000 mGy*m ²		
Acquisition Dose(RP) Total:	0.777000 mGy		
Total Acquisition Time:	0.2820 s		

The Dose Report image contains the study/patient data and dose parameters divided into four groups:

- 1 **Patient and Study data** that shows:
 - Patient name,
 - Paziente ID,
 - Patient's birthdate,
 - Patient's sex,
 - Institution name,
 - Physician's name,
 - Exam type,
 - Study date and time,
 - Accession number.

- 2 **Total Accumulated X-Ray dose data** that shows:
 - Total number of radiographic frames,
 - Total DAP dose,
 - Total Air Kerma.

- 3 **Fluoro Accumulated X-Ray dose data** that shows:
 - Total DAP dose in fluoroscopy mode,
 - Total Air Kerma in fluoroscopy mode,
 - Total acquisition time in fluoroscopy mode.

- 4 **Acquisition Accumulated X-Ray dose data** that shows:
 - Total DAP dose in digital radiography,
 - Total Air Kerma in digital radiography,
 - Totale acquisition time in digital radiography.

Once the **Dose Report Image** has been created, the button is deactivated until a new acquisition is made. The image can be managed through the DICOM STORE, DICOM PRINT, LOCAL PRINT functions and can be saved on USB device.

Note: to activate this function, see Paragraph 4.2, Section 2 of the Technical Manual.

3.8 ENTERING TEXT



You can add a comment to the image (text) by using this key:

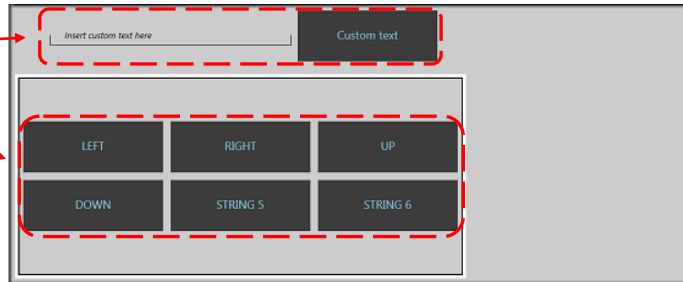

The following window appears, letting you:

- Enter free text
- Enter set text programmed during installation (fixed strings)

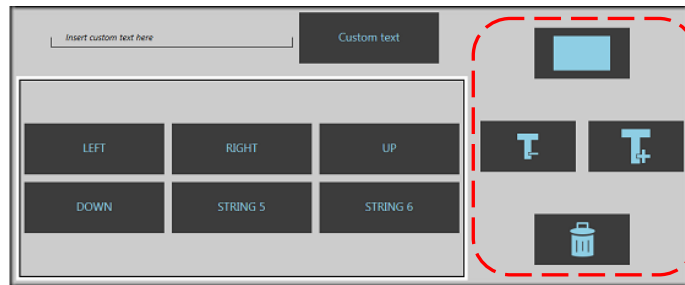

- After selecting the type of text in this menu, touch the position on the image where you want to add the text; if necessary, drag the text with your finger to move it.
- If necessary, by touching the text you can also:



	change the background color (transparent or black)
	increase or decrease the size of the text
	delete the text

Note: See the Technical Manual paragraph 4.8, Part 2 for instructions on how to create new "fixed strings".

3.9 GRAPHIC FUNCTIONS

Touch the following key to activate the graphic functions:



The following window appears, with these symbols:

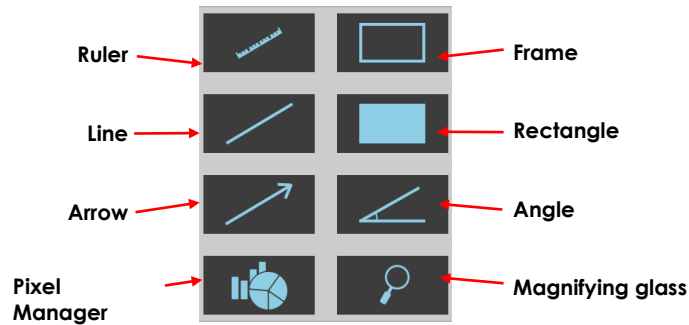

3.9.1 MEASUREMENTS - RULER

This function lets you measure linear segments in the image.



After selecting this function

- Use your finger to draw a segment (ruler) between the two points you want to measure. A line automatically appears with the measurement in mm.

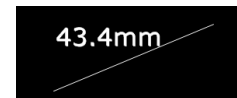

Note: The measurement in mm refers to the surface of the FPD; if the anatomical part in question is not in contact with the FPD, you will need to calibrate the image as explained below.

- You can also move the ruler to correct the position:

- moving the ends by touching one of the ends and then moving it with your finger or the direction (arrow) keys.
- moving the entire segment, by touching a central part of the line and then moving it with your finger or the direction (arrow) keys.

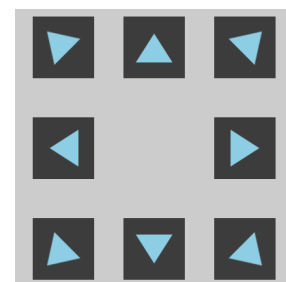
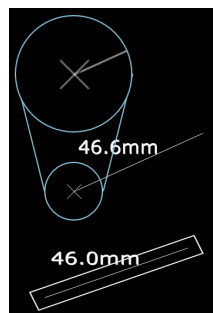

Note: the direction keys move the object in steps of 1 pixel each time you touch these. In case that no calibration has been carried out on the image, the indicated measurement will be preceded by the ~ symbol (for instance: ~ 50.0 mm).

The measurement is, however, shown without this symbol if the calibration has been carried out as described in the following chapter.

- You can also select the segment for an existing measurement and then:
 - decrease or increase the size of the measurement using these commands:
 - delete the segment using this command:

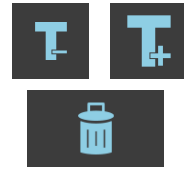

Once you delete the segment, in order to make a new measurement it is required to press again the **Ruler** icon.

3.9.1.1 CALIBRATION

The calibration function lets you correct linear measurements by setting a known length (calibration detail) in the image.

- Draw a segment over the calibration detail of known size.
- Enter the known length of the calibration detail (in mm) in the relevant field and then touch the **Set** command: all the measurements on the image will be re-calculated on the basis of this new calibration.

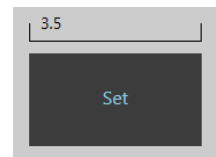

Note: The calibration applies to the whole run, provided that all the images were acquired using the same FPD zoom field.

After the calibration procedure, the precision of the measurement is about $\pm 3\%$.

3.9.2 MEASUREMENTS – ANGLE

This function lets you measure angles in the image.



After selecting this function:

- Use your finger to select the 1st end, the vertex and then the 2nd end of the angle on the image. The angle is automatically drawn and its value shown.

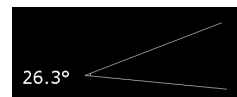

Note: The angle measurement always refers to the smaller angle (less than 180°).

- You can also move the following to correct the position:
 - moving the ends or the vertex of the angle by touching one of these and then moving it with your finger or the direction (arrow) keys.

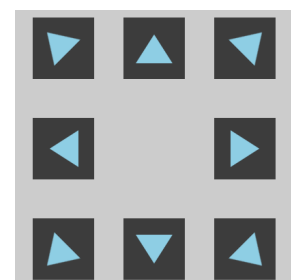
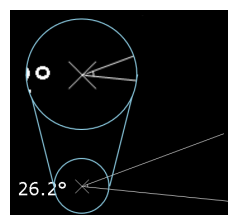

- moving the entire angle, by touching a central part of one of the two lines and then moving it with your finger or the direction (arrow) keys.

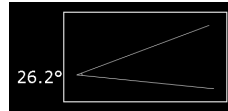

Note: the direction keys move the object in steps of 1 pixel each time you touch these.

- You can also select an existing angle and then:
 - delete the angle using this command:



Once you delete the angle, you need to press the **Angle** icon again to make a new measurement.

3.9.3 GRAPHIC OBJECTS

You can also add graphic objects to the image.

To highlight an area of interest in the image, use one of these objects:

- Line
- Arrow
- Frame

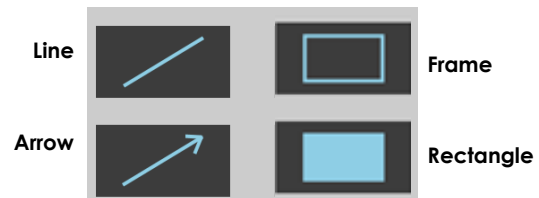

To cover a part of the image, use this object:

- Rectangle

After selecting the relevant function:

- Use your finger to draw:
 - a line (for a Line or Arrow)
 - or
 - the diagonal of the rectangle (for Frame or Rectangle)

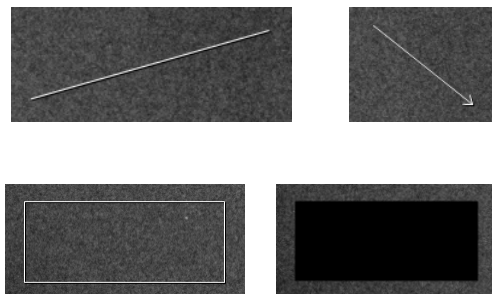

The selected object is automatically drawn on the image.

- If necessary, by touching the object on the image you can also:
 - move it, by touching it and then moving it with your finger or the direction (arrow) keys.
 - change it, by touching a side or angle and then moving it with your finger or the direction (arrow) keys.

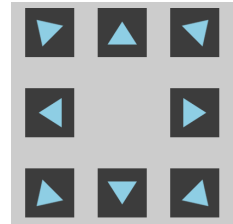

- delete the object using this command:



Once you delete an object, you need to press the relevant icon again to draw a new graphic object.

3.9.4 MAGNIFYING GLASS

Pressing the relevant key, this tool enlarges a particular point on the image. It magnifies of two times (2x), a circular area of 150 pixels of diameter.



Touch the point of interest to see it enlarged, as shown in figure aside. Until the function is enabled, whatever point is touched on the image, it will be shown enlarged.

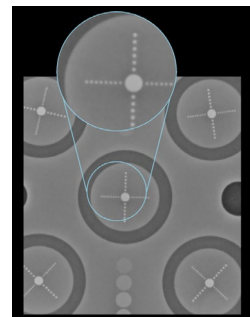

To disable the function, press again the relevant key.

3.9.5 PIXEL MANAGER

The Pixel Manager function is used by the Technical Service when checking the system and can only be used by Administrator and Advanced users. It lets you find the co-ordinates and the value of the pixels forming the image.

To use this function, touch the key shown:

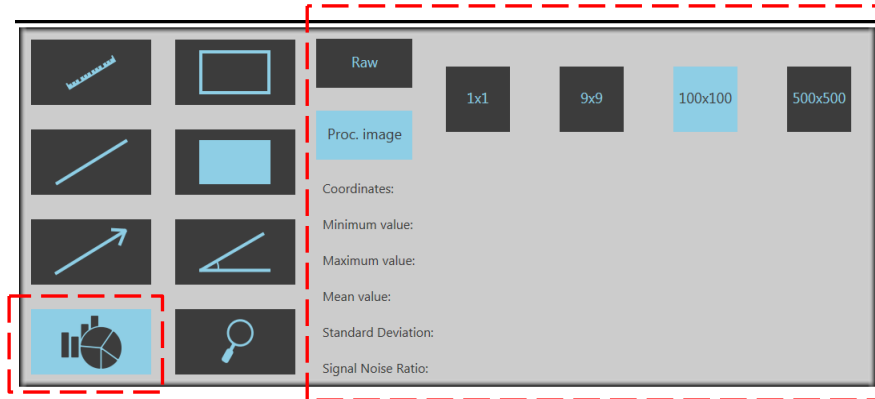

- You can select a portion of the image in which to read the pixel values:
 - 1x1 Pixels
 - 9x9 Pixels
 - 100x100 Pixels
 - 500x500 Pixels

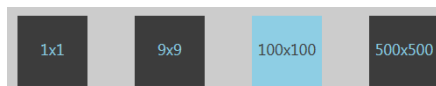

Use the **Raw** setting to detect the unprocessed image levels at the time of acquisition by the FPD. Alternatively, use the **Proc. image** setting to measure the levels after processing.

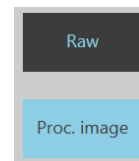

The following values are displayed:

- **Coordinates:** the X and Y coordinates of the pointer
- **Minimum value:** Minimum value in LSB
- **Maximum value:** Maximum value in LSB
- **Mean value:** Mean value in LSB
- **Standard deviation:** Standard deviation
- **Signal noise ratio:** Signal noise ratio

Coordinates:	660/603
Minimum value:	9575
Maximum value:	18538
Mean value:	14935.0
Standard Deviation:	1108.942
Signal Noise Ratio:	13.468

3.10 QUITTING THE STUDY

Touch the following key to close the current study and return to the Study List:



Note: this very same exit key is also present on the Control Panel.

4. DIGITAL SUBTRACTION ANGIOGRAPHY (DSA)

4.1 INTRODUCTION

The DSA function allows you to acquire images in subtraction mode. This means that an image is subtracted from another, in order to see only the differences.

The DSA function is enabled when selecting a DSA exam which has been preset during installation (to enable the DSA functions for a specific exam, see *Paragraph 4.4, Part 2 of the Technical Manual*).



The various **DSA acquisition** modes possible for the chosen exam are shown together with the other preset techniques.

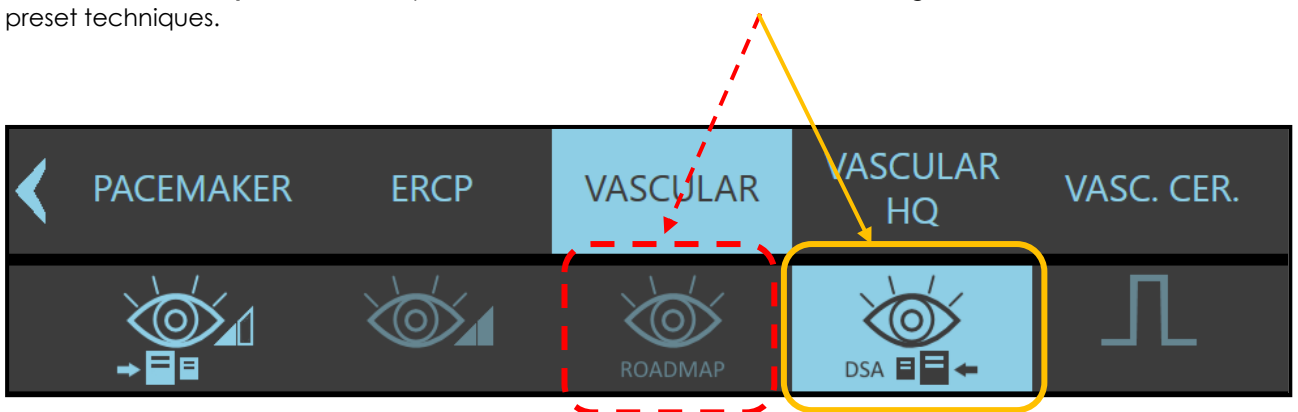

4.2 ROADMAP

ROADMAP mode consists of two phases:

- The first X-ray emission creates the **Max Opacification** image, fixing the opacity peak trace left by the contrast agent as it passes through the vessel.
- The following X-ray emissions produce images subtracted from the **Max Opacification** image that has been set as a mask. This function makes it easier for you to control the introduction of a catheter in the vessel (**Road Mapping**).

On selecting ROADMAP acquisition mode, icons appear for the two phases, together with the **Max Opacification** progression bar.

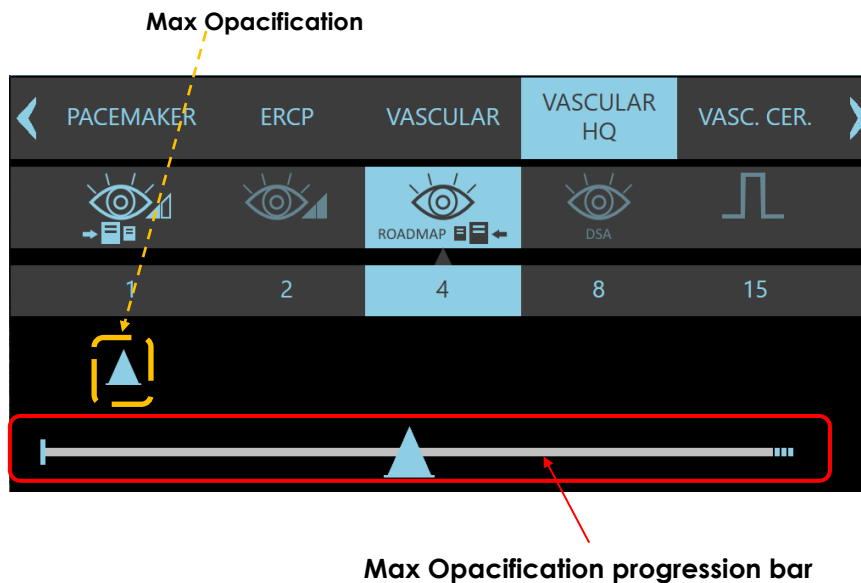

The triangle on the progression bar indicates when the function starts to 'fix' the path of the contrast agent. There is a 2-3 second delay between X-ray exposure and the start of the Max Opacification function (set during installation). This is needed to allow for automatic stabilization of the exposure parameters.

- When you press the the X-Ray control (footswitch or button), X-Ray emission starts and the progression bar turns yellow

Max Opacification acquisition mode starts once the triangle is reached:

- the **Injector** symbols are added to the **Max Opacification** triangle on the image in acquisition,
- the operator can now start to inject the contrast agent,
- the path of the contrast agent will be shown on the monitor and saved.



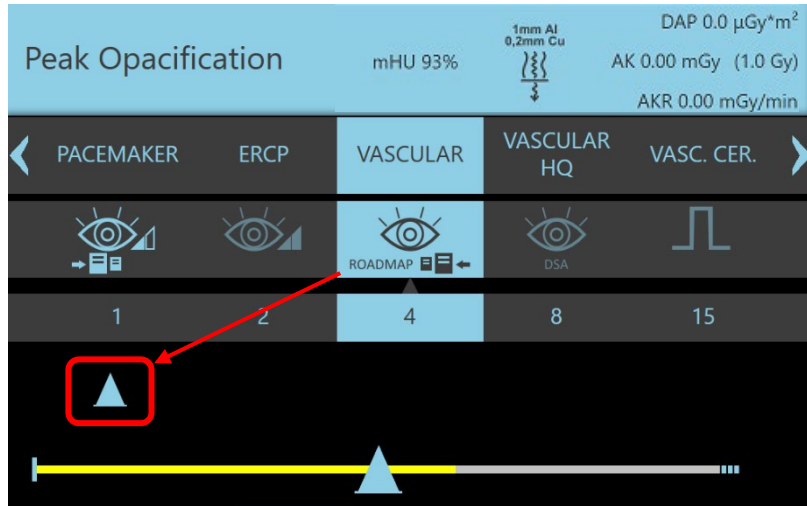

When the injection is over, release the footswitch/handswitch x-ray command: on the monitor is displayed **Max Opacification** image.

The **Road Mapping** phase starts with the next X-Ray emission. The subtraction between the live image and the Max Opacification image is now shown on the monitor: the vessel with the contrast agent appears "white", while the catheter shape will be "black".

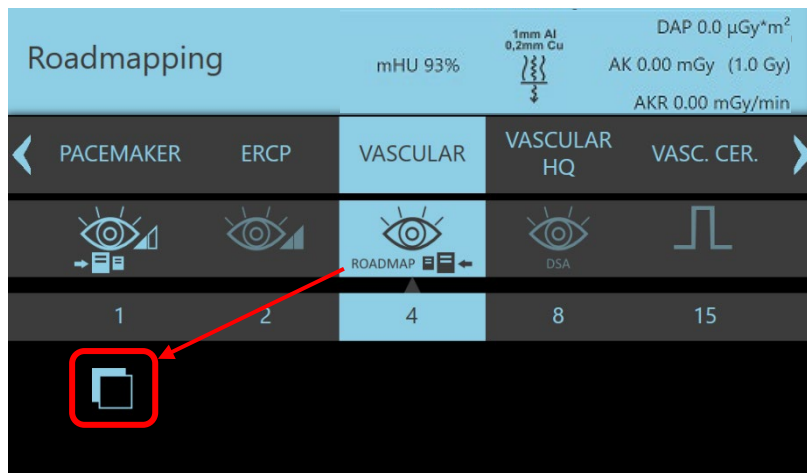

Any further X-ray emissions will still be in **Road Mapping** mode.

Press the ROADMAP button or another acquisition mode button to quit this function.

4.3 DSA FLUOROSCOPY MODE

The following parameters are automatically set when you choose a DSA exam in fluoroscopy mode, in addition to the normal parameters provided for non DSA exams. These DSA parameters can be programmed and set during installation:

Parameter	Settings	Notes
Number of acquisition phases with defined duration and acquisition rate.	Two phases (AutoSequence ON) or a single phase (AutoSequence OFF).	The exam can have a maximum duration of 40 seconds (up to 10 seconds head start for the injector, if required, and up to 30 seconds X-ray emission).
Duration of the phases. With AutoSequence ON , the duration of the first phase can be set (the duration of the second is variable according to the operator's requirements).	With AutoSequence function enabled, you can set the duration of the first phase from 0 to 25 seconds. The second phase will end 30 seconds after the start of the X-ray emission or on releasing the exposure command.	Before carrying out the exam, the operator has the possibility to change the phase duration on the Control Panel
Acquisition Rate for each phase.	It depends on Max FPS set in the Exam Setup . Usually, the acquisition rate of the subsequent phase is lower than the preceding one.	The operator has, however, the possibility to change the rate of the phase on the Control Panel. This is possible either before or during the exam.
Automatic injector command.	Injector ON or OFF .	If set to Injector OFF , the automatic injector command will be disabled. If set to Injector ON , but if the injector is not connected or not loaded, the automatic injector command will be disabled (yellow symbol, status OFF). If set to Injector ON , and if the injector is connected and loaded, the automatic command is enabled (green symbol, status ON): the injector start will be given according to the set advance or delay time (see following), which is indicated by the symbol on the sequence progression bar.
Advance or delay of the injector start with regard to the exposure start.	From -10 seconds (max. settable advance) to +25 seconds (max. settable delay).	This setting comes predefined with the exam, but the operator can still modify it on the Control Panel. Whenever the injector is programmed to work in advance, pressing the X-ray command will start the injector.
Delay for automatic mask pick-up with regard to start of the X-ray emission.	Ranging from no delay at all up to 25 seconds.	Before carrying out the exam, the operator has the possibility to change this parameter on the Control Panel.

Once you select DSA FLUORO, the window for setting the acquisition sequence will appear.

The following pictures show an example with 2 acquisition phases.

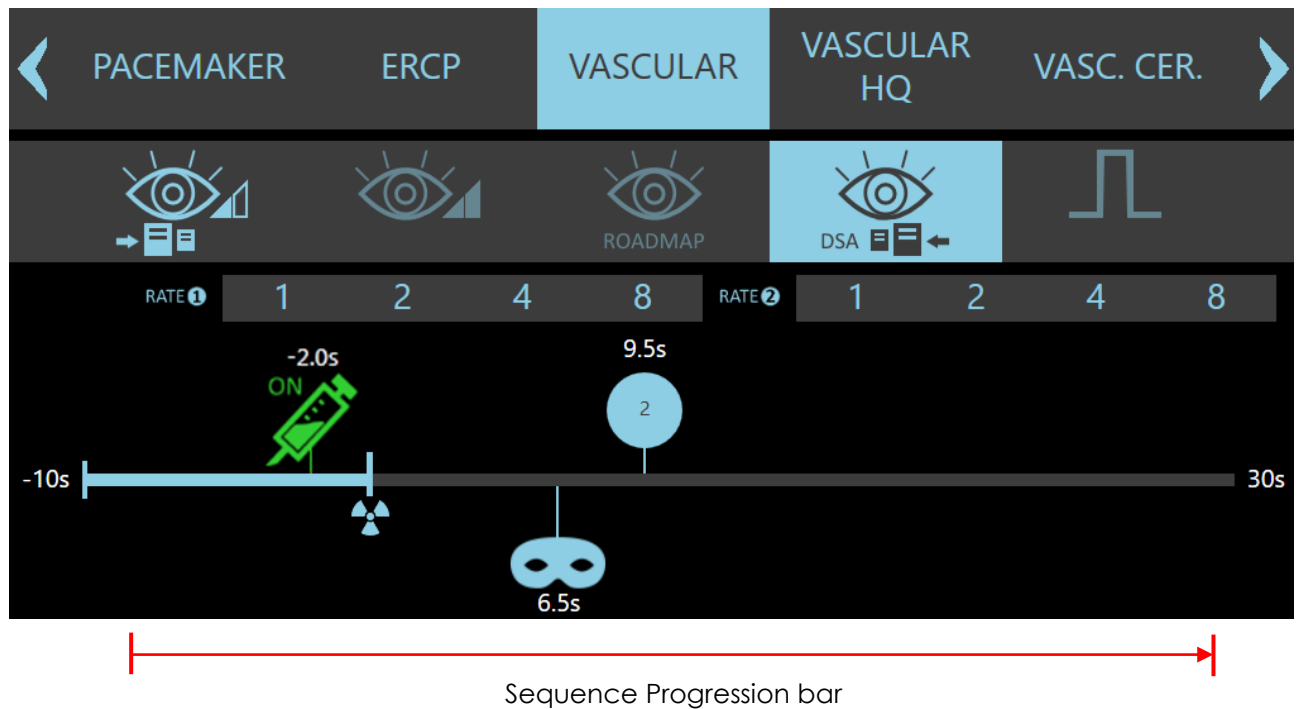

This icon represents the moment the X-ray exposure starts (zero point). This is the only icon you cannot move along the bar.

The section of the bar before this icon lets you set the anticipation between the injection and the start of X-ray exposure.



This symbol shows the injector status: if the injector is connected and loaded, the symbol will be green; otherwise it will be colored yellow and marked with the word OFF. Moreover, the symbol shows the injector starting time (in seconds). It can be either negative, meaning an advance start or positive for a delayed start with regard to the start of the X-ray emission.

Before starting the acquisition, the time parameter can be changed by moving the injector symbol along the progression bar (it cannot be moved beyond the symbol for mask image pick-up).



This symbol shows the delay (in seconds) with regard to the start of the X-ray emission for the mask image pick-up. Before starting the acquisition, the time parameter can be changed by moving the mask symbol along the progression bar.



The time in seconds indicated by this symbol corresponds to the starting time of the second phase with regard to the beginning of the X-ray emission, (it shows basically the duration of phase 1).

The time parameter can be changed by moving the symbol along the progression bar.

It is possible to change the rate of each phase by picking the required value from the selection list. The rates can even be changed during acquisition.

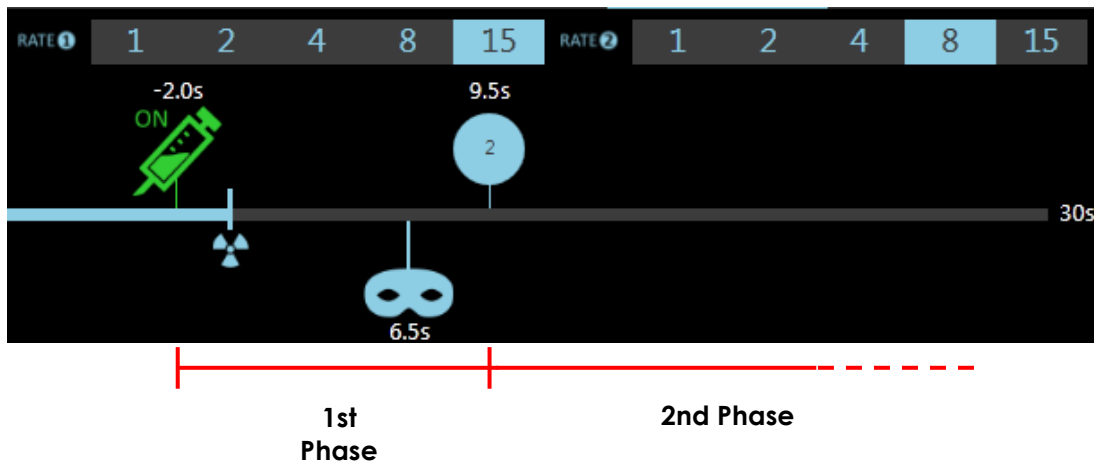

• The sample picture above shows the following:

- 1) When pressing the X-ray command, this will trigger the injector start. After 2 seconds (advance time set for the injector start), the X-ray emission will begin at a rate of 15 fps.
- 2) After 6,5 seconds from the beginning of the X-ray emission, the mask pick-up command is given: from this moment on, the subsequent images will be shown in subtracted mode.
- 3) After 3 seconds (9,5 seconds from the beginning of the X-ray emission), the first phase comes to an end and the acquisition rate decreases to 8 fps (2nd phase). The phase ends automatically once the time of 30 seconds from the beginning of the X-ray emission has been reached, or earlier if the X-ray command is released. If the X-ray command is pressed once again, the same sequence will start over again.

4.3.1 INJECTOR

The EM equipment is ready to command the start of a contrast media injector system. The function can be programmed within the DSA exams and allows a synchronized command of the device (either with a set advance or delay) with regard to the X-ray emission.

There is no preset injector: the connector shown below provides generic interface.

As a result, this function will only be available once the installer has completed the necessary electrical interface for a specific injector that he wants to use (*).

(*) Note: See Paragraph 6.2, Part 5 of the Technical Manual for further details on the electrical connection of the injector.

With the equipment and all devices switched off, connect the injector interface cable to the connector shown in the figure below.

- Switch the equipment and devices on.
- Select an anatomical option compatible with the injector (**only DSA exams allow the use of an injector**).



If the injector is connected and loaded, the corresponding symbol will be green, meaning that the injector is ready for use during the exam.

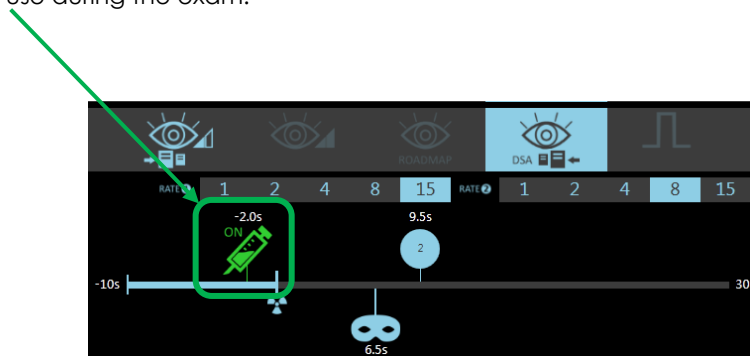

If, however, the injector is not connected nor loaded, the corresponding symbol will be yellow, meaning that the injector will **not** be activated by the EM equipment during the exam.

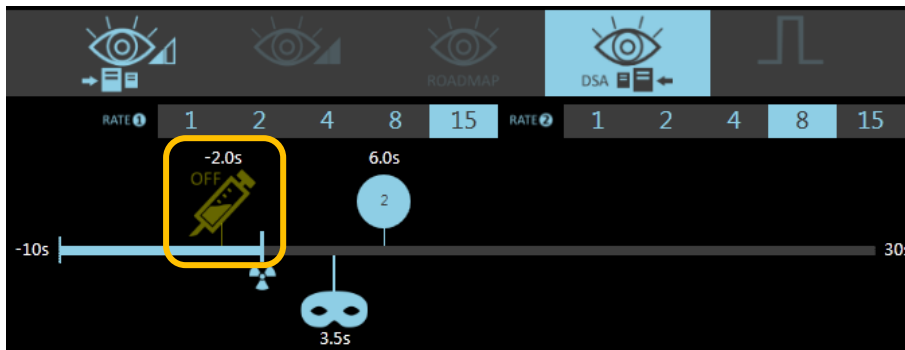

When pressing the X-ray command (foot- or handswitch), the DSA sequence will begin. If the injector has been set to start in advance with regard to the X-ray emission, the DSA sequence will begin by starting the injector.

If, on the other hand, the injector has been set to start with a certain delay with regard to the X-ray emission, the EM equipment will start the injector once the sequence has reached the injector symbol; the progression of the sequence is shown by the corresponding bar which turns to yellow.

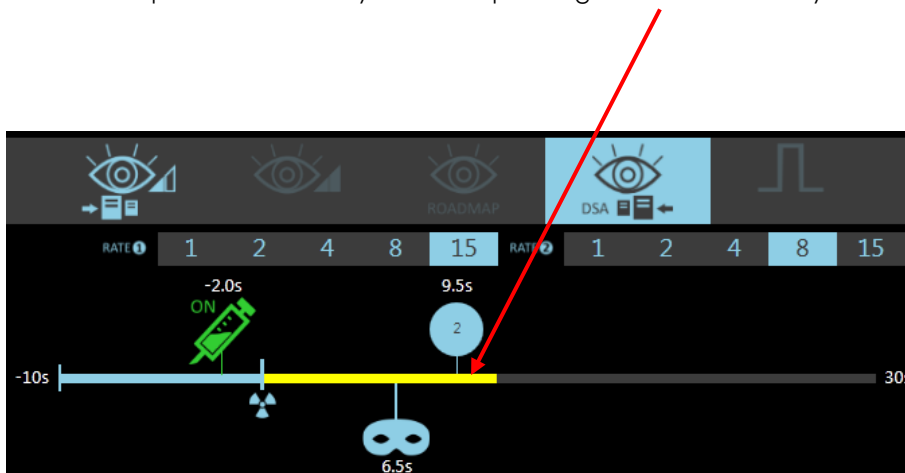

At the end of the acquisition, the injector returns disabled.

4.3.2 DSA ACQUISITION WITH FIXED PULSE RATE

In case the DSA sequence is programmed with a single acquisition phase (**Auto Sequence** function disabled, see Paragraph 4.4.1, Part 2 of the Technical Manual), the acquisition rate will be the same for the entire sequence.

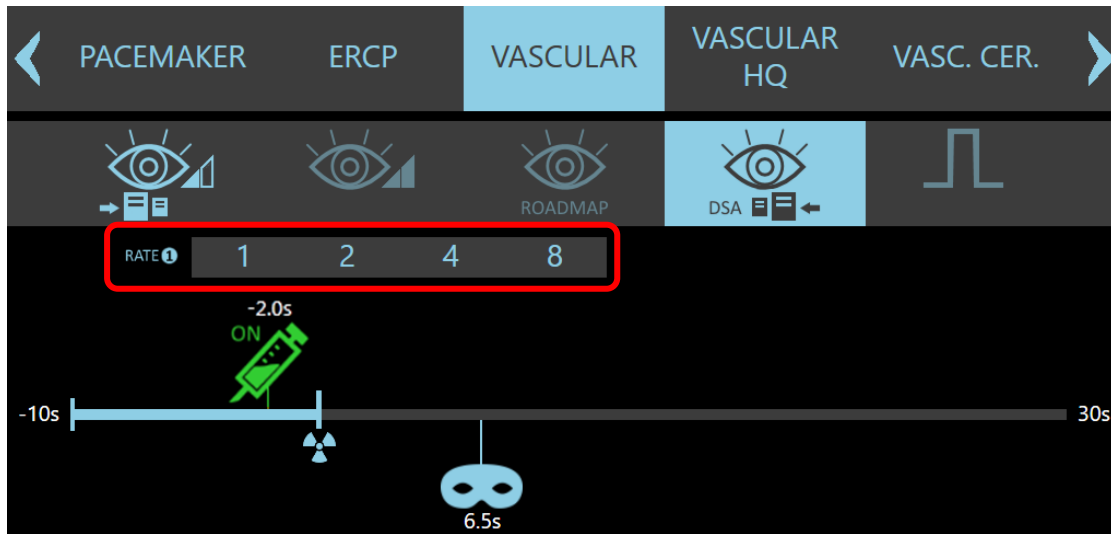

When selecting the DSA acquisition mode, the system automatically sets the rate predefined by the exam. The operator can, however, select a different value from those shown on the Control Panel either before or during the acquisition.

4.3.3 DSA ACQUISITION WITHOUT AUTOMATIC MASK PICK-UP

The sequence can be set without the automatic mask pick-up.

In this instance, the mask must be picked manually during acquisition using:

- the **mask** icon on the Control Panel,
- or the **mask button** on the remote control.

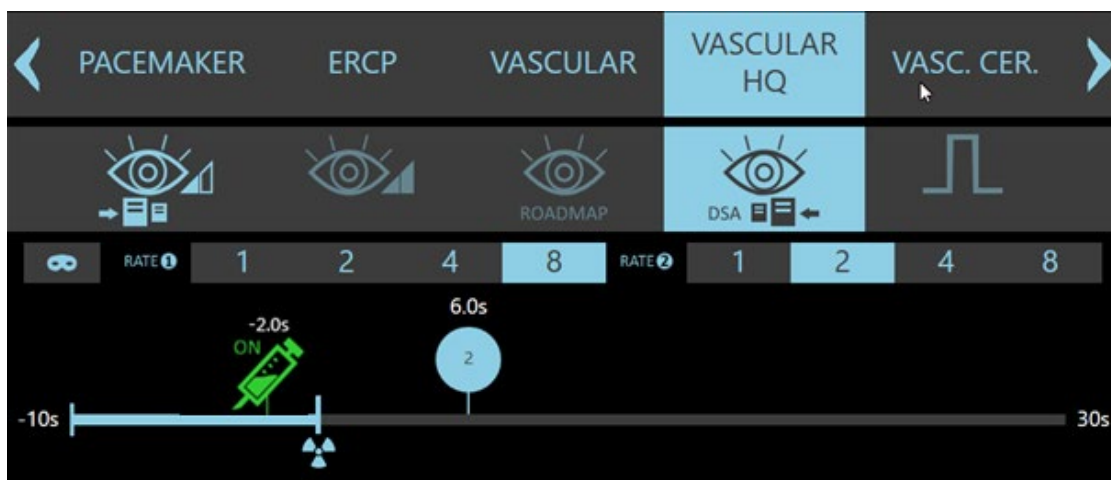

Note: the mask can even be set after acquisition, during the phase of post-processing.

4.4 DSA POST-PROCESSING

All the DSA sequences are saved to hard disk.
The images can thus be displayed or processed in the **storage area** of the **monitor** using the post-processing functions. Certain post-processing functions are only available for DSA images.

The latter functions can be accessed by pressing the key on the monitor shown in the red frame below.

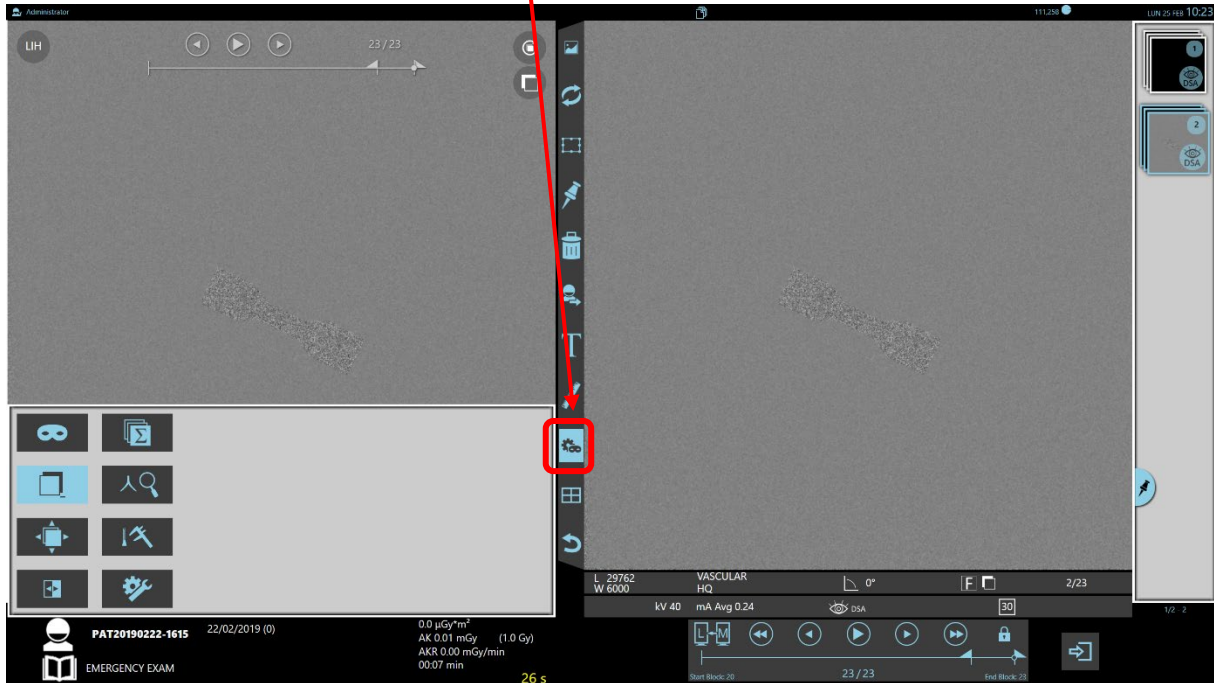

1. "Mask" button



2. "Image Subtraction" button.



3. "Shifting Pixels" button.



4. "Land Marking" button.



5. "Vascular Tracing" button.



4.4.1 DESCRIPTION OF THE ANGIOGRAPHIC FUNCTIONS

Once the DSA sequence of interest has been selected, it is possible to carry out the usual image viewing functions using the **Cine-loop** command (see Paragraph 2.4.1.2, Part 2) as well as the **Post Processing** commands (see paragraph 3, Part 2) already described.

The **Cine-loop** starts with the image following the one picked as mask image. Furthermore, the following functions are available:

• **Mask selection:**



If you press this button, the viewed image will be set as the mask and this marker appears on the image.

This marker tags a mask image.

All the images in the sequence are now shown as subtracted images using this mask image.

You can repeat the procedure to choose a new **mask** image in the sequence (**Remasking**).

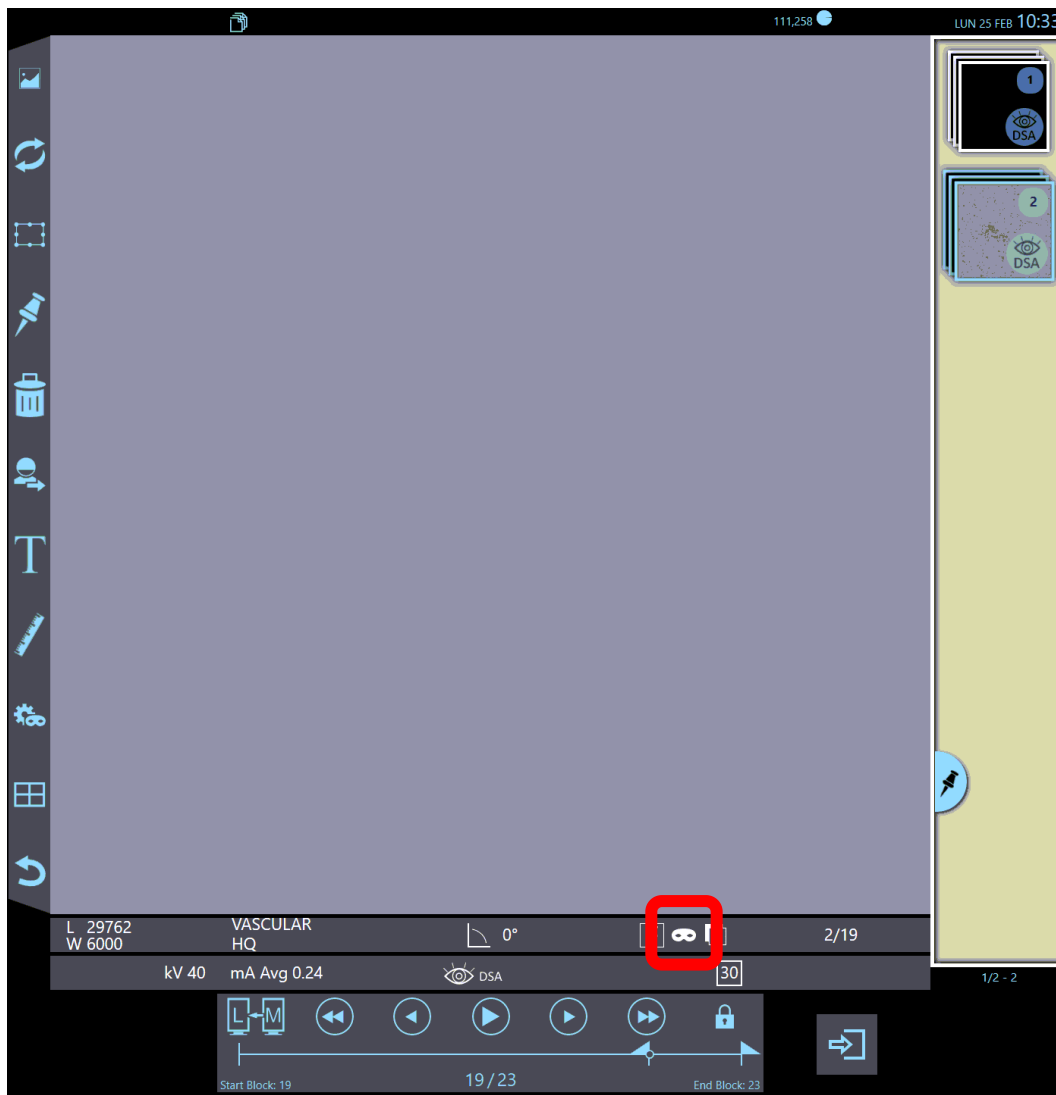

• **Image Subtraction:**



The images of the sequence can be displayed as normal or subtracted images. Using the **Image subtraction** key, it is possible to switch the visualization mode of the images from subtracted to normal mode (and the other way around).



• **Pixel shift:**



Movements made by the patient or in the position of the C-arm during acquisition can create artefacts on the subtracted image. The **Pixel shift** function lets you the mask image to realign the images.

The menu shown below opens when you press this icon on a subtracted image. Use the direction buttons to move the mask image to realign the edges.

You can move the image by:

- 0.25 pixel  or 1 pixel  steps.
- The central button restores the original image alignment. 

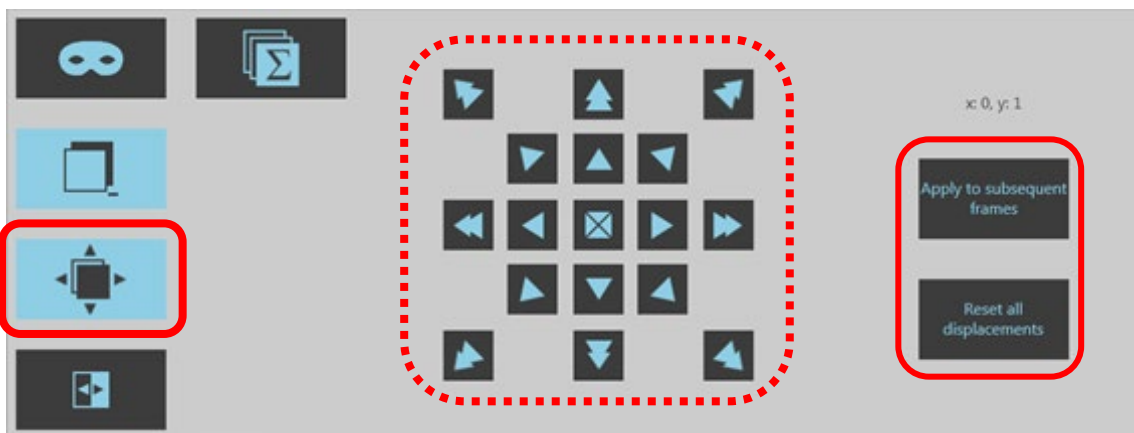

Once the necessary shift has been done, you can either apply it also to all subsequent frames or cancel all the movements carried out with one of the corresponding keys.

• **Land marking:**



The **Land mark function** lets you overlay a section of the mask image over the subtracted image in order to create an anatomical point of reference for better orientation.

This function is only available for subtracted images.

The overlay percentage between the two images can be set using a dedicated slide bar:

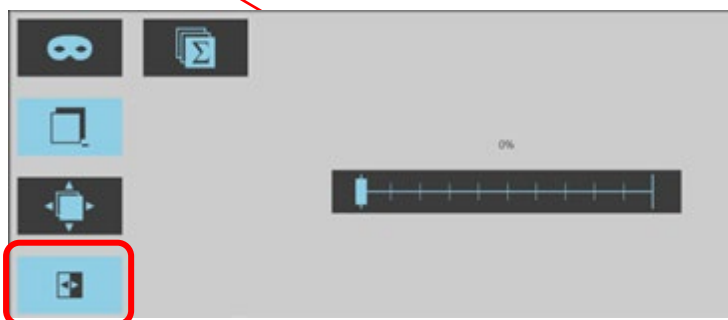

- 0% Normal Subtraction
- 100% Image not subtracted.

• **Vascular Tracing:**



This function lets you create a new image from the sum of any subtracted images selected within a run.

Press this button to open the following menu: This function is only available for subtracted images.

Image sum (vascular tracing):

This function is very useful and lets you reconstruct the entire course of the contrast media in the blood vessels. The following commands are available:

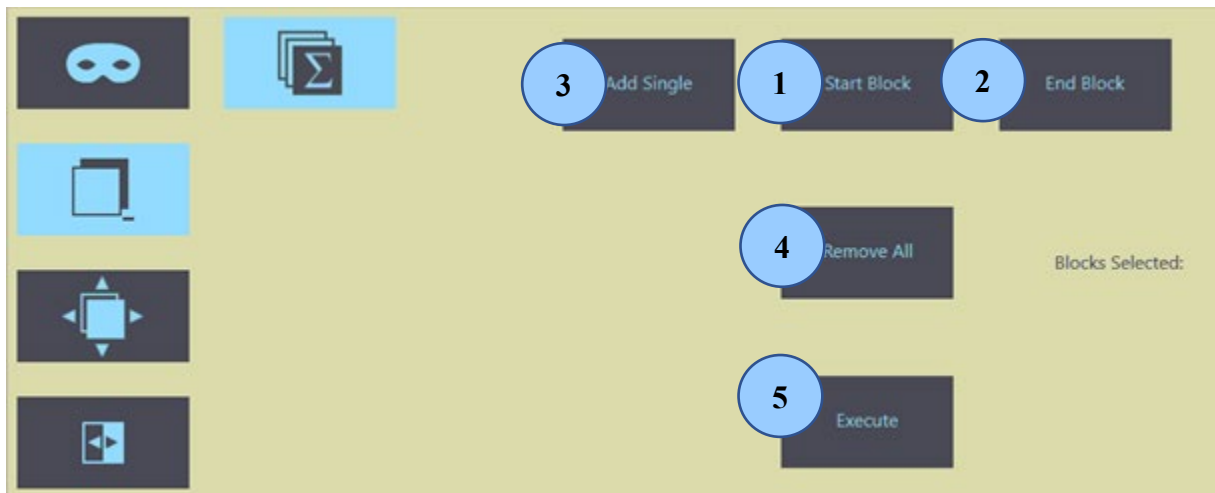

- 1) **Start block:** it defines the present image as the first image of the series that will be covered by the image sum function.
- 2) **End block:** it defines the present image as the last image of the series that will be covered by the image sum function.
- 3) **Add single:** it adds a single image to the sequence which will be covered by the image sum function (it will be sorted in the order of acquisition).
- 4) **Remove all:** it removes all images selected for the sum function.
- 5) **Execute:** it generates the image sum.

The image sum is stored and shown in the study previews.
If necessary, select the image and use the Land marking function (see *previous page*) to get a better visualization of anatomical landmarks.



5 MAINTENANCE AND PRODUCT DISPOSAL

See the **Technical Manual** for details of extraordinary maintenance, required in the event of a fault or the replacement of parts.

This manual only deals with routine maintenance operations.

5.1 ROUTINE MAINTENANCE

5.1.1 GENERAL RECOMMENDATIONS

The EM equipment requires regular checks and maintenance.

The following recommendations are aimed at avoiding malfunctions and maintaining proper safety conditions.

The equipment contains mechanical parts subject to wear and tear as a result of their use. After a prolonged period of use, it is possible that safety will be reduced due to wear and tear of the components.

Regular inspections and maintenance are also needed to protect patients and operators from injury arising from broken mechanical parts.

Correct adjustment of the electromechanical and electronic modules directly affects the efficiency of the equipment, image quality, electrical safety and the irradiation exposure level to which both hospital personnel and patients are subjected.

The maintenance schedule consists of checks and preventive measures. These are the responsibility of the owner and should only be carried out by expressly authorised personnel.



Always use original spare parts whenever parts that can affect machine safety need to be replaced.

5.1.2 USER CONTROLS AND INSPECTIONS

The user must ensure that his operators receive special training to carry out the daily and weekly checks detailed in the table below.

Any other checks should be carried out by authorized qualified Technical Service personnel.

Daily:	Check that the signals, displays, laser localizer and LEDs are working. Check that the warning and danger signs are not damaged. Check for unusual noises coming from the monoblock during X-ray emission. Check the X-Ray dose level (see paragraph 1.7.1). Check the efficiency of the DAP (see paragraph 1.7.2). Check the max aperture of the X-ray collimator (see paragraph 1.7.3). Checking the safety of the motorized up/down C-arm movement (see paragraph 1.7.4). Check the adjustment of the monitors (see paragraph 1.7.5).
Weekly:	Check for oil leaks coming from the monoblock. Check the state of the cable sheaths. Check the integrity of the power supply cable. Check the integrity of the footswitch command connector cable. Check the integrity of the handswitch command connector cable.



Any other checks (described in the Technical Manual) should only be carried out by qualified and authorized Technical Service Personnel in line with local rules and requirements.

5.2 CLEANING AND DISINFECTING

Do not use cleaning products that have a high alcohol content to clean the surfaces of the equipment. Do not use corrosive detergents, abrasive products or solvents.

Only use disinfectants that fully comply with existing disinfecting and explosion prevention procedures and regulations.



Observe the following precautions when cleaning and disinfecting:

- Switch the equipment off and unplug at the mains.
- Make sure that no liquids infiltrate the equipment to prevent short circuits and corrosion of the electrical and electromechanical components.
- Clean the panels with a soft damp cloth and a little soapy water.
- Make sure the panels are completely dry before using the equipment again.
- When cleaning the monitor, always add the soapy water to the cloth first, before wiping the screen.
- **Before cleaning the footswitch, unplug the connector from the stand, if present.** The footswitch must be cleaned regularly and thoroughly, using a soft fabric with a general-purpose detergent.
The footswitch can be disinfected using isopropyl alcohol wipes (70%) or immersion in a disinfectant solution; finally rinse thoroughly under running water and dry carefully.

Note: *DO NOT use Chlorine based disinfectants that may lead to deterioration of the device.*



If using disinfectants that form explosive vapors/gaseous mixtures, make sure that these have had time to disperse before using the equipment again.

5.2.1 MICROBIC CONTAMINATION

To avoid problems with microbic contamination for patients and operators, the user must ensure that the equipment is protected using disposable sterile sheets, or sheets that can be sterilized.

Note: *Sterile sheets are not provided from the EM equipment manufacturer. Always use sheets sterilized that comply with current local sterilization standards.*

5.3 REPLACING BATTERIES

5.3.1 REPLACING THE REMOTE-CONTROL BATTERY

The infrared remote control is powered by a **9 V DC battery, model 6LR61**.

The battery is flat when LED (L) fails to light up when you press any of the keys (fig.1a).

If you need to replace a flat battery (B), undo the screw (V) to remove the cover (C) on the battery compartment (fig.1b).

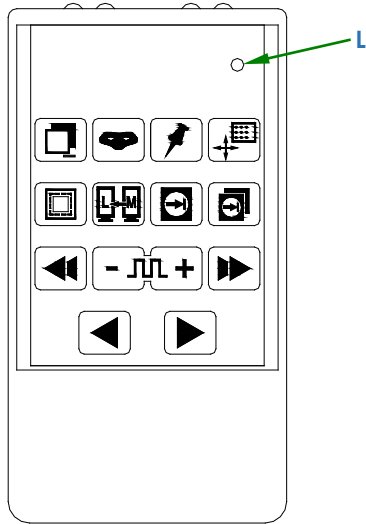

Fig.1a

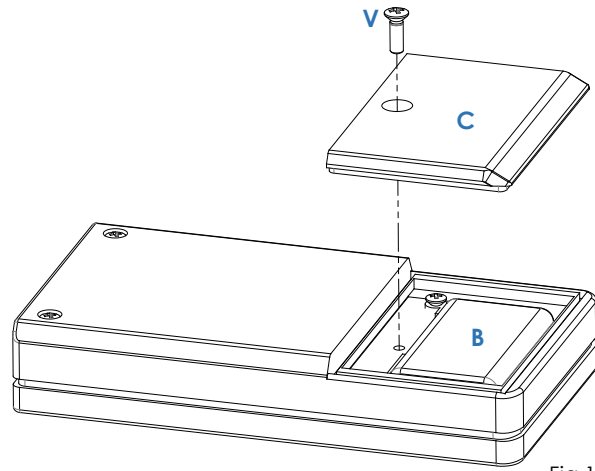

Fig.1b

Note: The infrared remote-control receiver is integrated into the stand (fig.2).

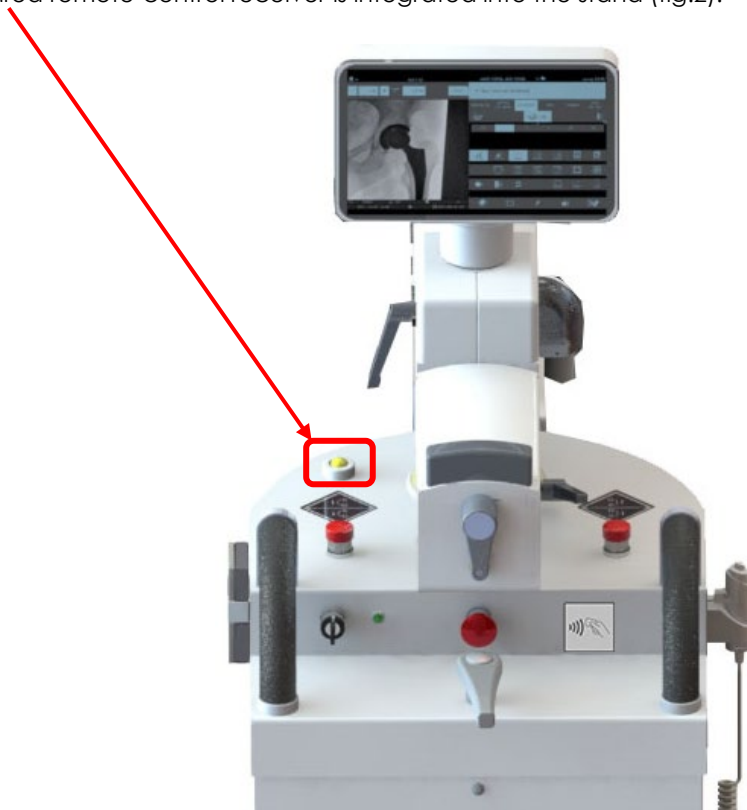
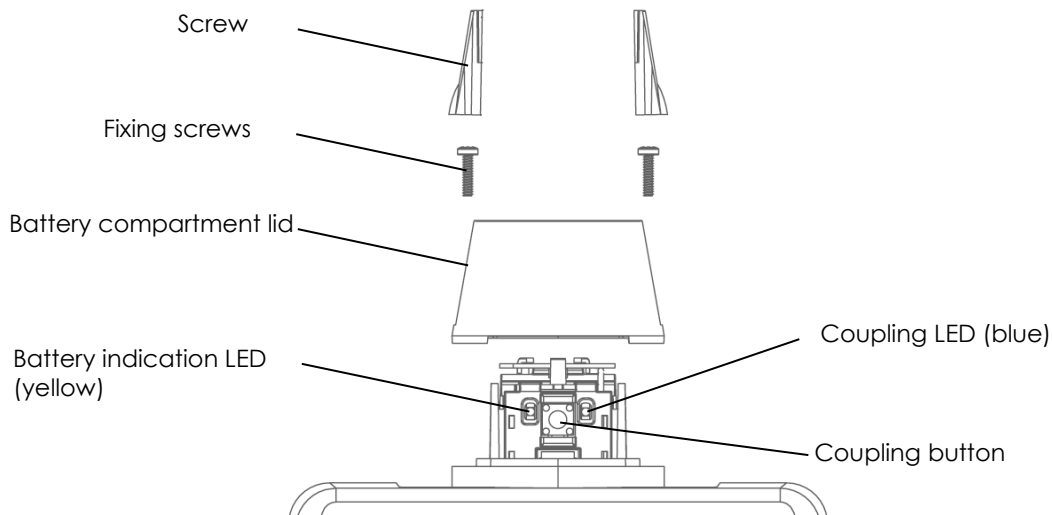

Fig.2

5.3.2 REPLACING WIRELESS FOOTSWITCH BATTERIES (OPTIONAL)

The wireless footswitch works with **2 alkaline batteries AAA (LR03)**. We suggest to change the batteries at a minimum of once a year (even if they are not out of power).



To replace the batteries, follow the instruction below:

- Remove the screw covers using a small flat bladed screw driver or similar,
- Remove the screws,
- Release both battery clip hinges simultaneously by carefully pushing the clips of the antenna support outwards,

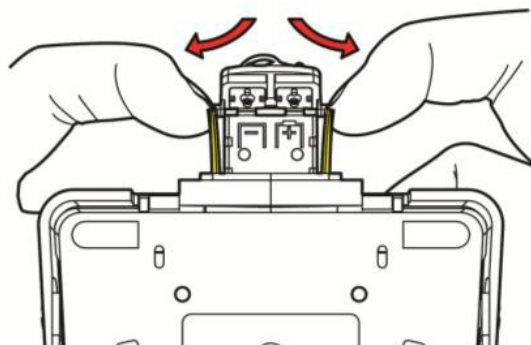

- Replace the batteries taking care to observe the polarity (use good quality **alkaline AAA (LR03) batteries**),

- Push the clip back into place by holding the sides of the clip, as shown in figure. Do not clip back into place by pushing on the antenna as this might damage it.

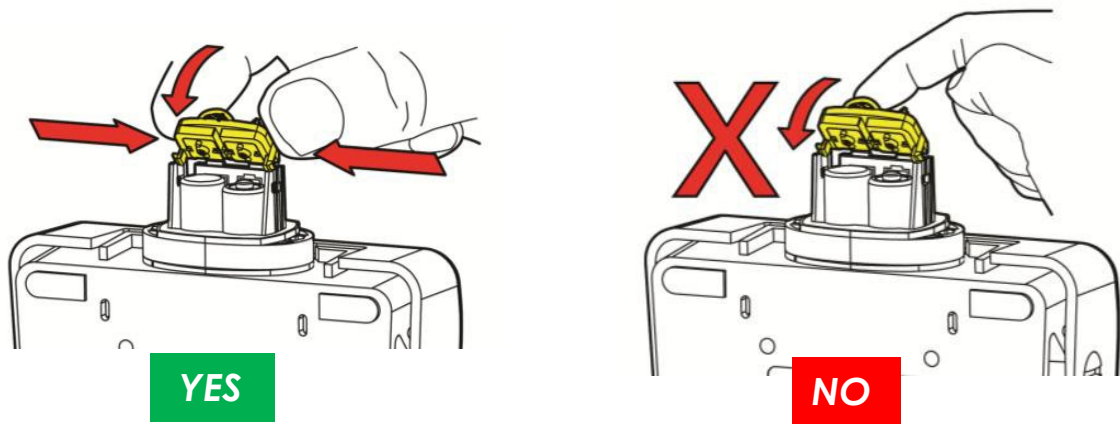

- Make sure the lid is in place, tighten the screws and finally press the screw covers back on.

5.3.3 REPLACING THE BACKUP BATTERY ON THE MOTHER BOARD

The manufacturer recommends changing the buffer battery of the video processor every three years.

The user will be advised as this time is over, at the login.

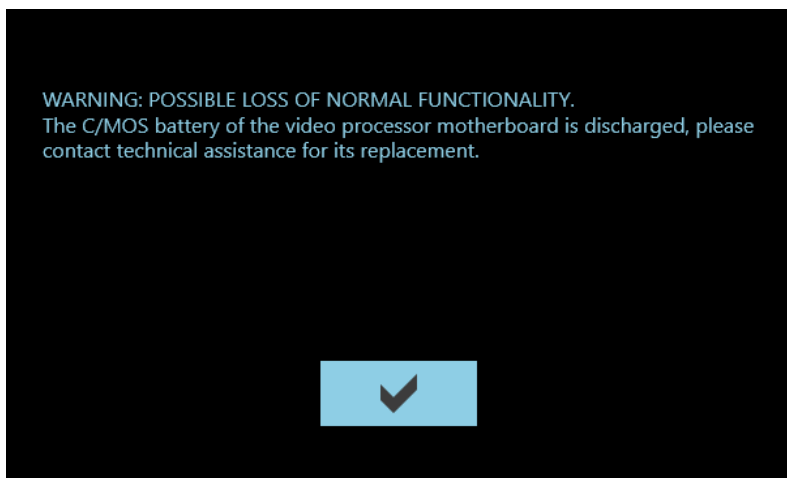

See Paragraph 6.5, Part 5 of the Technical manual for the replacing procedure.

5.4 X-RAY TUBE SEASONING PROCEDURE

Typically, x-ray tube seasoning procedure is required:

- at the equipment installation,
- after a period of inactivity longer than 2 months,
- in case of an electrical discharge in the X-ray tube.

The procedure involves a series of exposures at increasing kV values in order to reduce possible residual gas in the X-ray tube, before to use it at full load.

Moreover, it minimizes the irregular distribution of the potential / electric field on the tube glass.

Carrying out the recommended training procedure will help to prolong the life of the X-ray tube and to prevent electrical discharges of the tube (perceived as a noise, like the sound of a strong slap) that can potentially cause irreversible damage to the X-ray tube.

Follow the steps below to perform the procedure:

- Select the EXTREMITY exam.
- Close the X-ray collimator completely.
- Execute the exposures following the parameters of the three phases below.



Attention: before performing an X-ray exposure, control that all necessary radiation protections have been taken.

During the emission of x-ray, the staff in the room must comply with the regulations regarding radiation protection.

Phase 1 X-ray emission in Digital radiography

ITEM	kV	mAs	Expositions number	Time between exposures (in seconds)
1	80	25	28	5
2	80	0,5	3	5
3	90	0,5	3	5
4	100	0,5	3	5
5	110	0,5	3	5
6	120	0,5	20	5

Phase 2 X-ray emission in Fluoroscopy Low Dose mode, at 4i/s

ITEM	kV	mA avg	Expositions time (in seconds)	Time between exposures (in seconds)
1	80	1,5	30	5
2	90	1,3	30	5
3	100	1,2	30	5
4	110	1,1	30	5
5	120	1,0	60	5

Phase 3 X-ray emission in Digital radiography

ITEM	kV	mAs	Expositions number	Time between exposures (in seconds)
1	80	8	5	5
2	90	8	5	5
3	100	8	5	5
4	110	8	5	5
5	115	8	10	5
6	120	8	20	5

5.5 PRODUCT DISPOSAL

5.5.1 PROCEDURES AND PRECAUTIONS

When scrapping the device, special care must be taken when handling the following components as these can be hazardous when scrapped:



- The flat panel detector contains **cesium iodide doped with thallium** and **lead** that must be considered toxic materials.
- The LCD monitor has a **screen** which, should it break, can send shards of glass flying and disperse substances that may be toxic.
- The monoblock contains a **vacuum tube** which, should it break, can send shards of glass flying; it also contains **lead** that must be considered a toxic material; it also contains exhaust **oil** which must be disposed of in accordance with the current local regulations.
- The X-ray collimator contains **lead**: this is a toxic material and must be treated as such.
- All flat batteries must be disposed of in accordance with European Directive 2006/66/EC and subsequent amendments (concerning batteries and accumulators and battery/accumulator waste).

Other parts of the equipment are made from:

- ferrous material (frames, etc.),
- plastic (covers and guards, etc.),
- wiring.

These parts are not considered to be a potential source of hazards when scrapping the device.



*All parts should be disposed of in accordance with the prevailing regulations in each country **at the moment of scrapping.***



The symbol on the right appears on the equipment to remind you that the equipment meets European Environmental Directive 2012/19/EU (handling of Waste Electrical and Electronic Equipment - WEEE) and so must be scrapped in accordance with the relevant laws for separated waste disposal.



This equipment must not be disposed of as normal municipal solid waste: it must be taken to an expert waste disposal center or returned to the dealer, should you wish to replace it with a new model.

6 **ANNEXES**

6.1 **CHANGING THE INTERFACE LANGUAGE**

The indications for the operator (status and alarm messages, warning, etc.) can be displayed in different languages.

The language is selected during installation of the equipment.

Contact the Technical Service or see the Technical Manual if you need to change the language (See paragraph 4.2, Part 2).

Note: For a full list of available languages, please contact the manufacturer.

6.2 USING THE KEYBOARD ON THE TOUCH SCREEN MONITOR

The touch screen monitor provides the only operator interface.

Whenever you are required to enter letters (like for example in the login screen, shown in the following image), an **alphanumeric keypad** will appear on the lower part of the monitor. This keypad can be moved to any point on the monitor by dragging it:

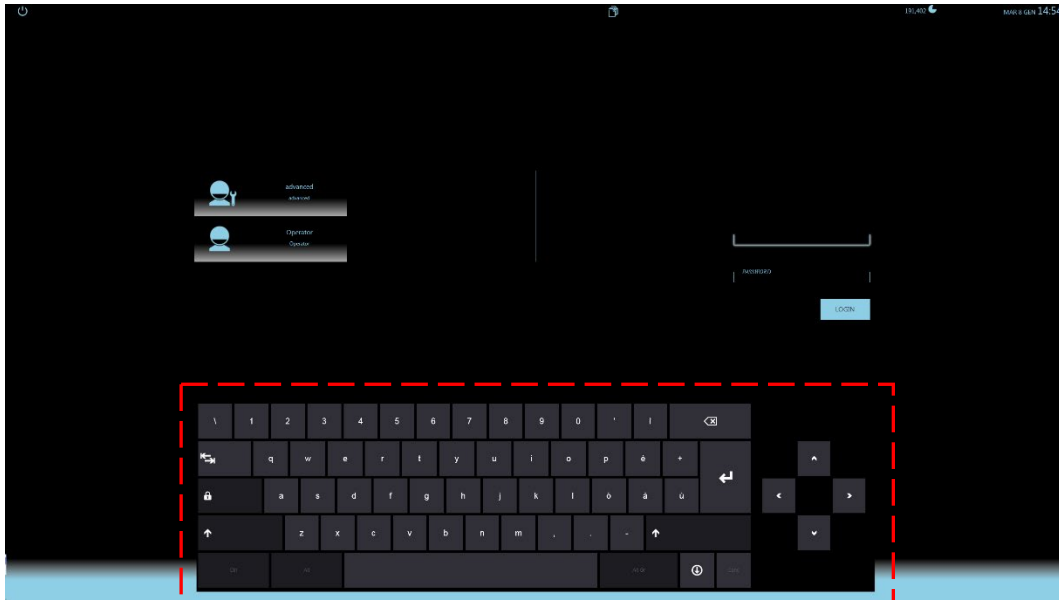

If you are asked to enter only numbers (e.g. when entering the weight of a new patient, as in the figure below), a **number pad** appears; again, you can move this to any point on the monitor.

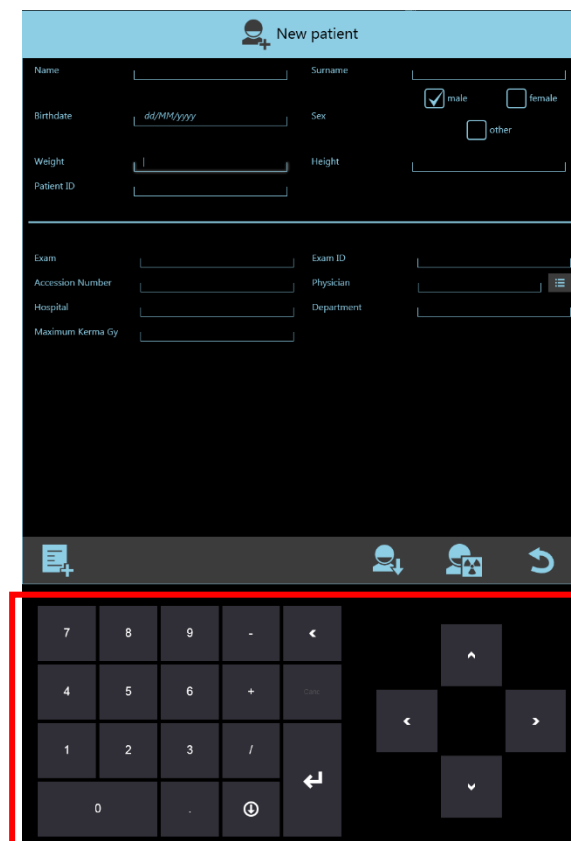

6.3 ADJUSTING THE MONITORS

You must check the correct monitor adjustments each time you log in.

A Test Image appears on both monitors; use this to verify the brightness and contrast:

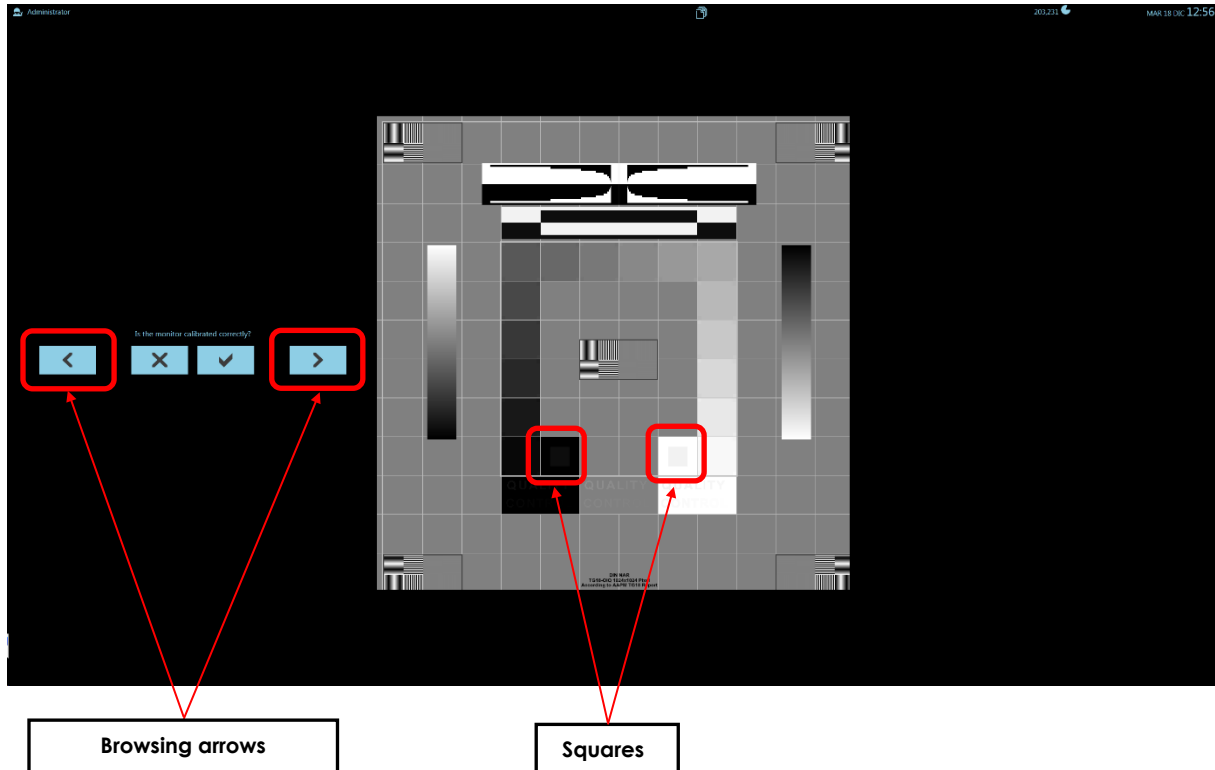

It must be possible to discern:

- the entire grey scale (0% - 100%),
- the grey square in the black box (position **A**),
- the grey square in the white box (position **B**).

If this is not the case, it might be necessary to have the monitor recalibrated (or replaced) **by the technical service**.

Note: It is possible to check the correctness of calibration on other images, too. Browse through the images with the relevant arrows. (aforementioned criteria still apply).

6.4 STUDY LIST MANAGER



Warning: the study archive must not be considered as a permanent storage solution. Every day, before closing the application and switching off the system, it is good practice to transfer all images to an external, general archiving device via the DICOM network (see Paragraph 6.5).

The following functions help you use and manage the Study List:

- Find study
- Select multiple studies
- Delete study

Note: the operations described below can also be carried out via the Control Panel.

6.4.1 SEARCHING A STUDY

The usual way to find an existing study in the Study List is to use the patient name.

- To enable the search function, touch the **Search** command:



- Enter the full (or partial) name of the patient: only those studies containing these data will be displayed.
- Touch the Search command again to return to the full list with all the studies.

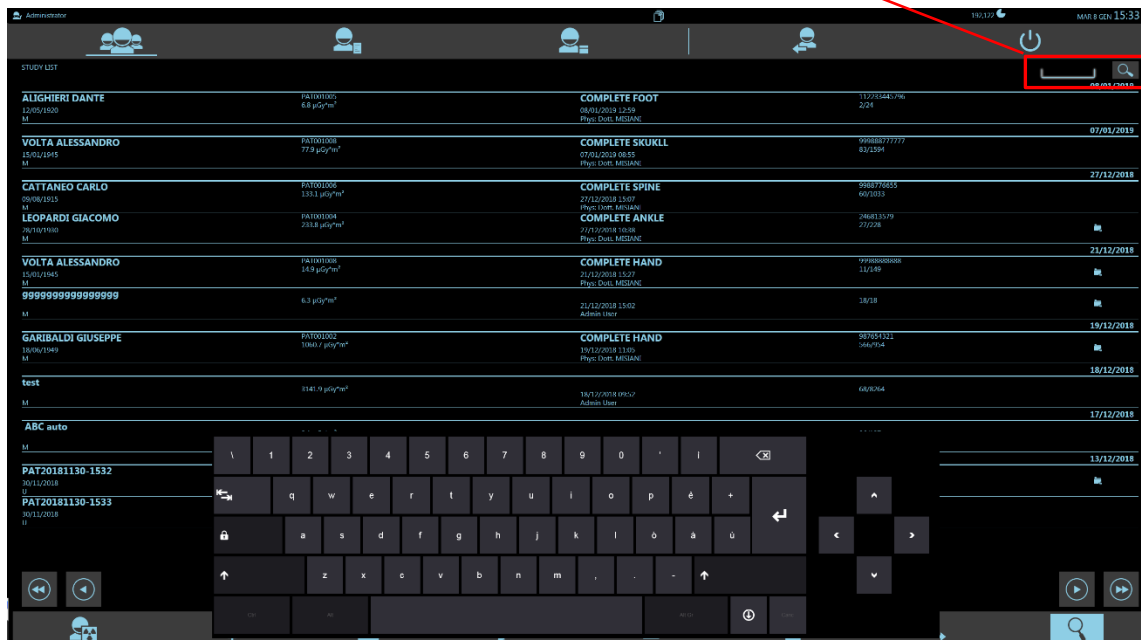

6.4.2 SELECTING MULTIPLE STUDIES

Use the relevant command to select more than one study in the Study List (e.g. to send them to a DICOM device or to delete them):



- You can now select the studies you want. They become highlighted:

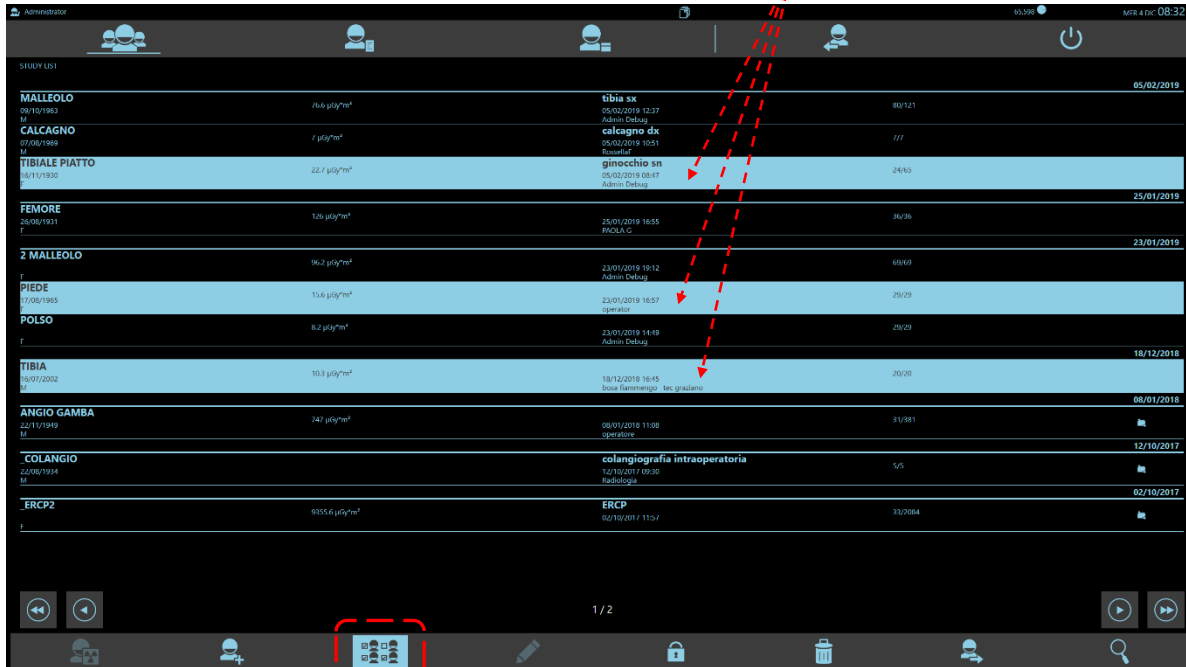

Enable multi-selection

6.4.3.1 PROTECTING A STUDY AGAINST DELETION

You can protect images in a study from accidental deletion.
After selecting the study, touch the protection command: **Lock**.



This icon indicates that the exam is protected against

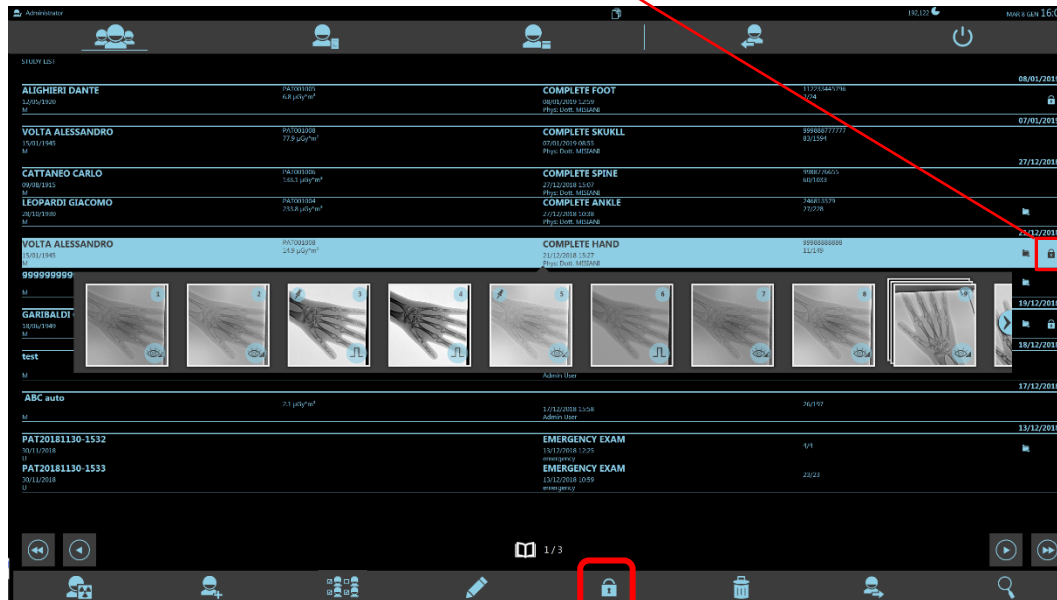

Lock key

The locked study can be unlocked by simply touching the same key again: **Lock**.

Note: Even single images in a protected study cannot be deleted.

6.5 TRANSFERRING IMAGES VIA DICOM

You can send images via the DICOM-3.0 protocol network:

- using the STORE DICOM function (see paragraph 6.5.1),
- using the PRINT DICOM function (see paragraph 6.5.2).

You can check whether transfer has been successful through the DICOM SPOOLER menu (see paragraph 6.5.3).

6.5.1 STORE DICOM

The EM equipment lets you transfer images to one or more STORE DICOM devices:

- from the Study List frame
- from the Image Processing frame

From the Study List frame, you can send:

1) one or more selected studies:

- select the **Store Dicom** command in the Image Report menu:

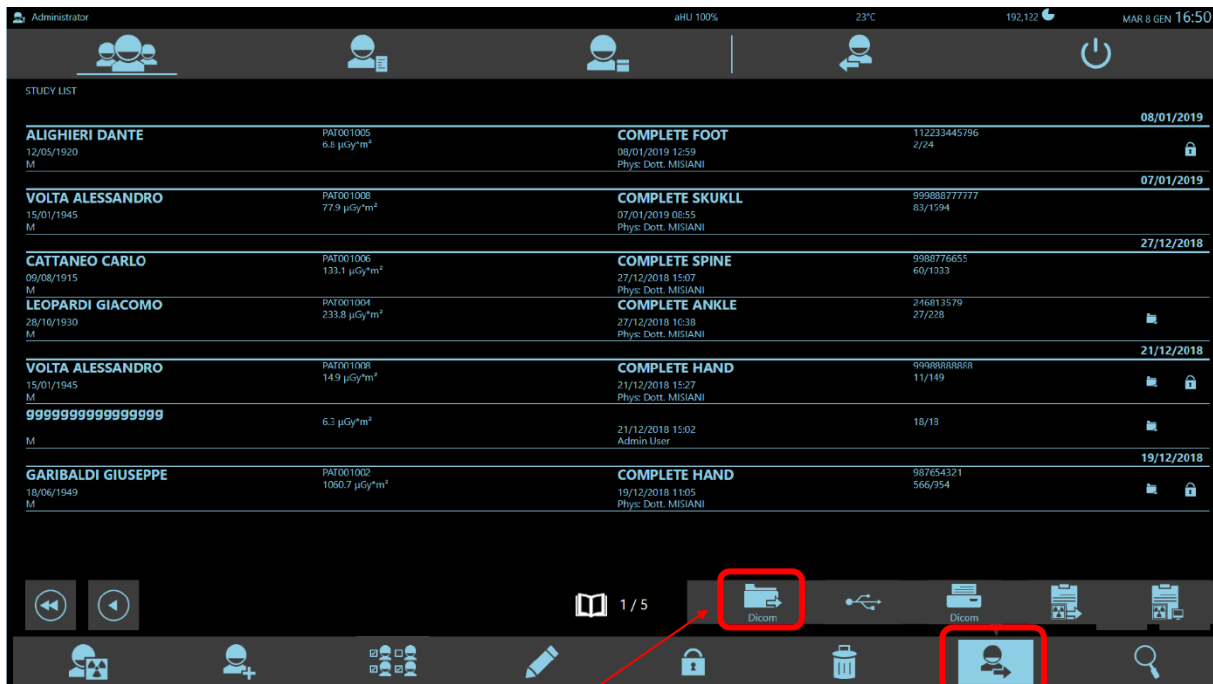

STORE DICOM command

Open Image Report menu

- The following selection window appears, letting you:

- Select which images you want to send:

- Whole study:** the entire study
- Pinned images:** only flagged images

- Select the storage device where to send the images

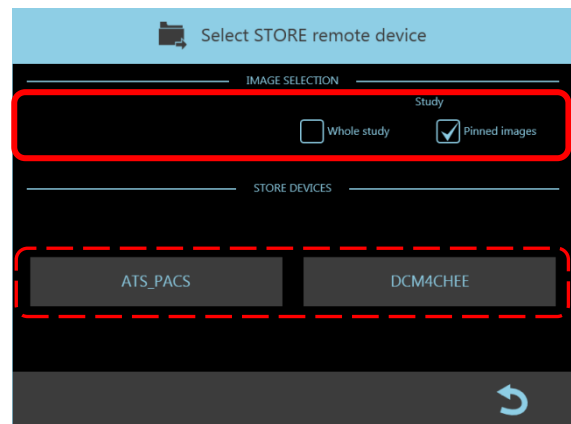

The Image Processing frame offers a choice of export options to suit the type of image selected:

- if you have selected a **single image**, touching the **Store Dicom** command in the Image Report menu:

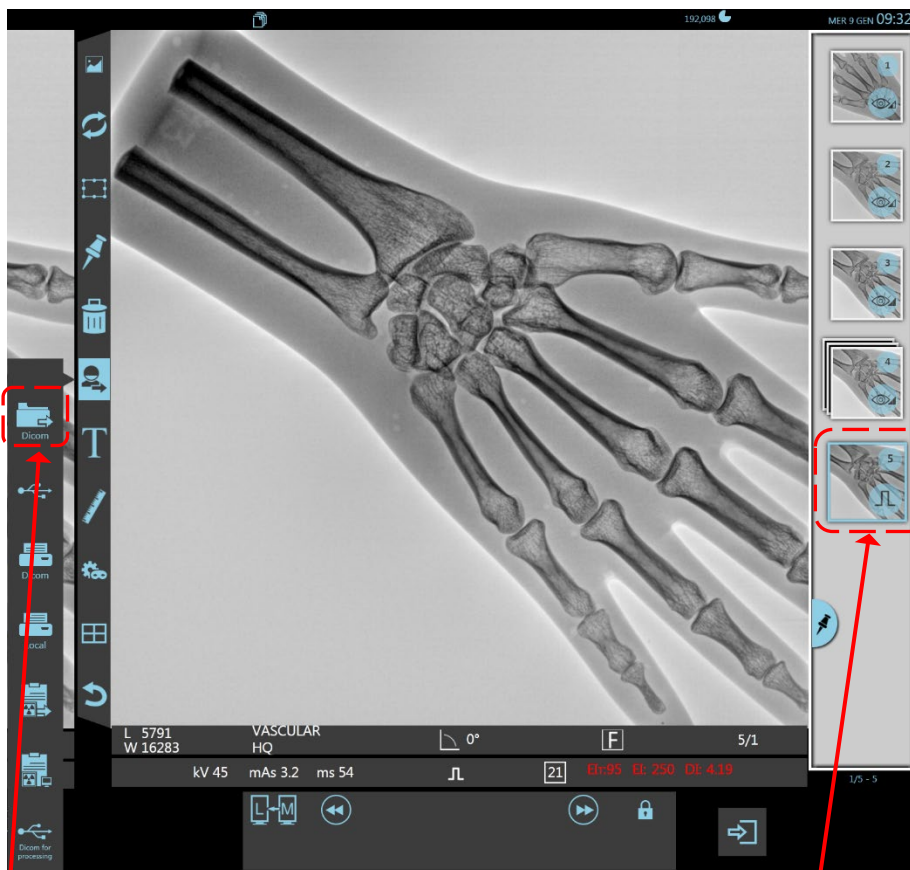

STORE DICOM command

SINGLE IMAGE SELECTION

- The following selection window appears, letting you:

- Select which images you want to send:

Current image: the selected image

Whole study: the entire study

Pinned images: the flagged images of the study

- Select the storage device where to send the images

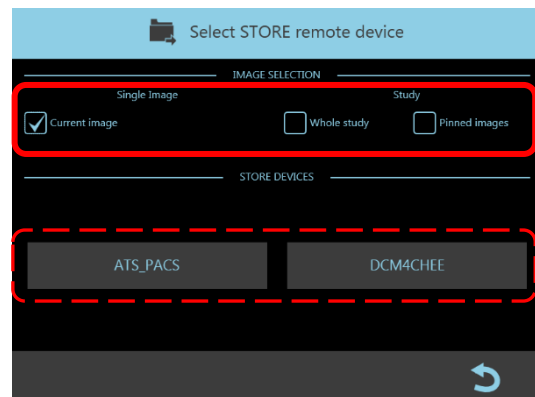

- if you have selected a **multiframe run**, touch the **Store Dicom** command in the Image Report menu:

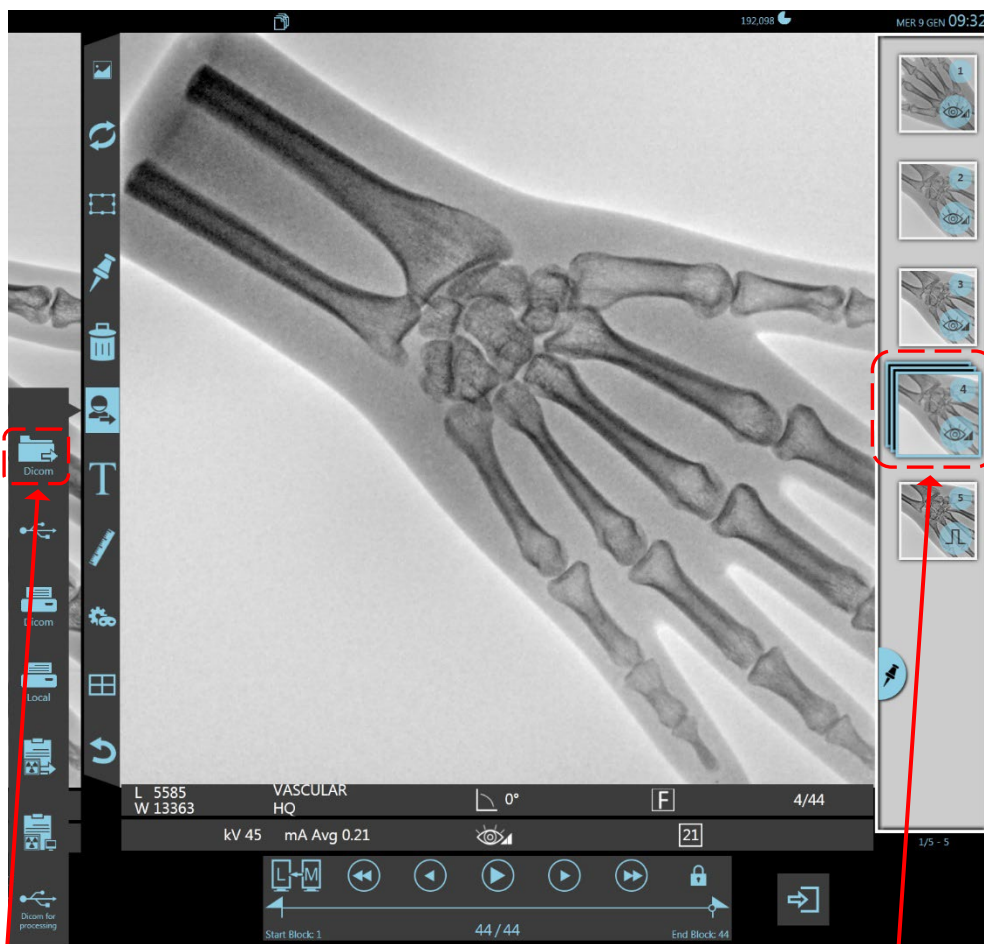

STORE DICOM command

SELECTED IMAGES SEQUENCE

- The following selection window appears, letting you:

- Select which images you want to send:

- All frames:** All images of the selected run
- Pinned frames:** all the flagged frames in the selected multiframe run.
- Whole study:** the entire study
- Pinned images:** all the flagged images in the study.

- Select the storage device where to send the images

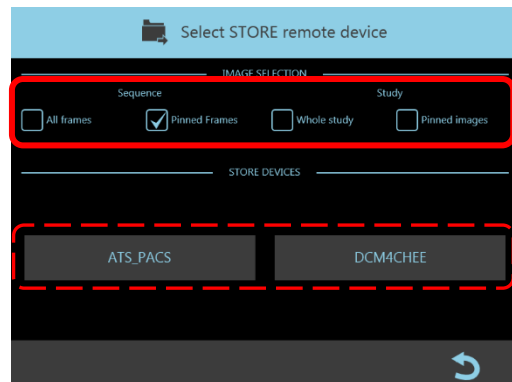

DICOM image creation and the following send spooler are notified by the message: **"Processing IMAGE: n"**.

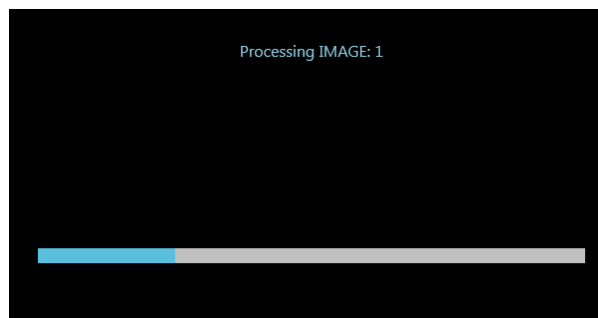

Warning: During DICOM images creation, new images acquisition is inhibited. So, it is suggested to carry out sending to store operation once the exam has been finished.

Note 1: If the images in the study are displayed in OVERVIEW mode, the procedure for sending these to the STORE DICOM device is the same as that indicated at points 2) and 3) above.

Note 2: If a MULTIPLE STORE DEVICE has been configured during installation (i.e. a device with several transmission nodes), you can select the node required as shown in the figure below:

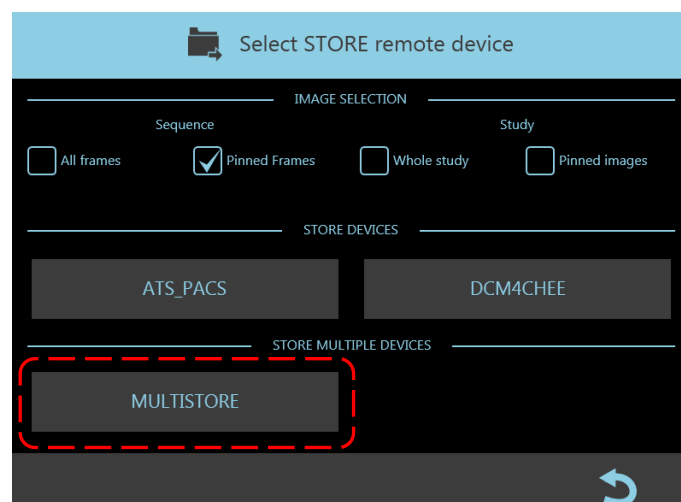

6.5.2 PRINT DICOM

The EM equipment lets you transfer images to a DICOM printer:

- from the Study List frame
- from the Image Processing frame

From the Study List frame, you can send:

- 1) one or more selected studies:
 - select the **Print Dicom** command in the Image Report menu:



PRINT DICOM command

Open Image Report menu

- The following selection window appears, letting you:

- Select which images you want to send:

- Whole study:** the entire study
- Pinned images:** only flagged images

- Select a print configuration from between those set during installation (max 4).

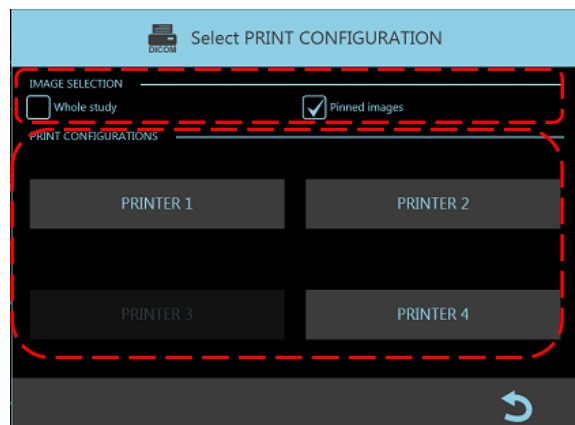

The Image Processing frame offers a choice of export options to suit the type of image selected:

2) if you have selected a **single image**, touch the **Print Dicom** command in the Image Report menu:

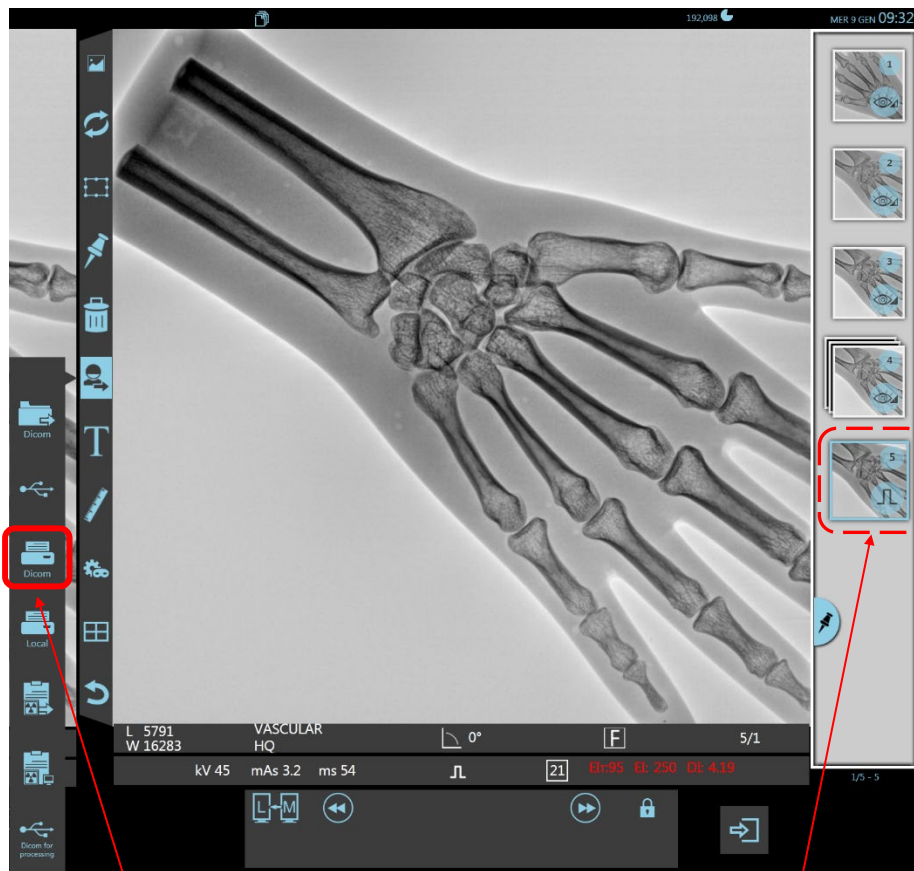

PRINT DICOM command

SINGLE IMAGE SELECTION

The following selection window appears, letting you:

- Select which images you want to send:

- Current image:** the selected image
- Whole study:** the entire study
- Pinned images:** only flagged images

- Select a print configuration from between those set during installation (max 4).

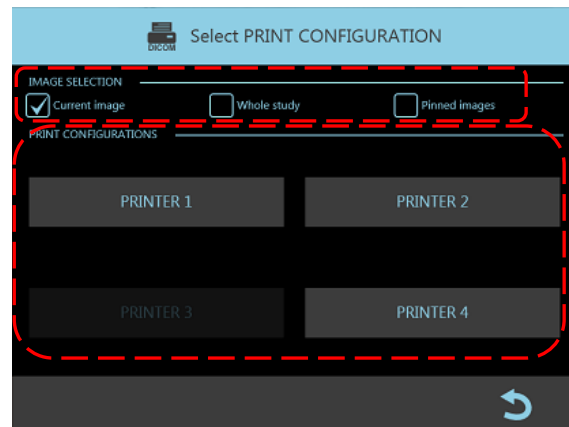

3) if you have selected a **multiframe run**, touch the **Print Dicom** command in the Image Report menu:

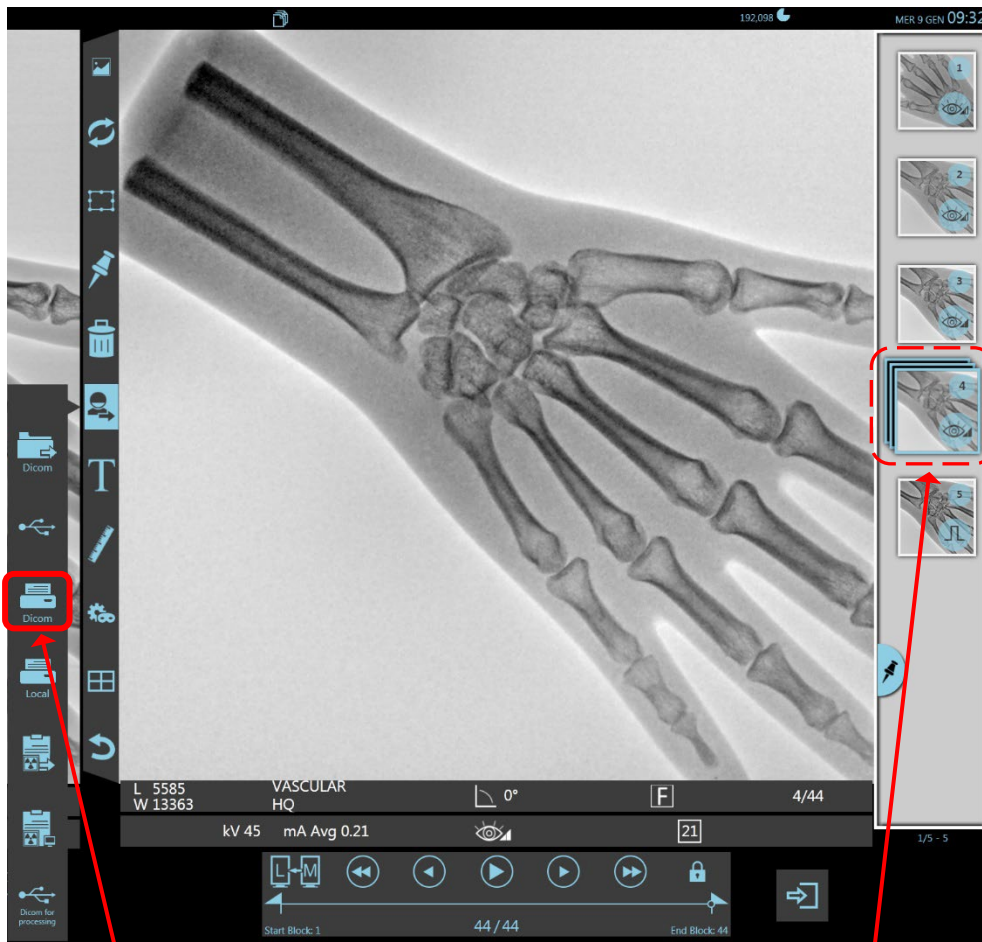

PRINT DICOM command

SELECTED IMAGES SEQUENCE

- The following selection window appears, letting you:

- Select which images you want to send:

- All frames:** all the images in the selected run
- Pinned frames:** all the flagged frames in the selected multiframe run.
- Whole study:** the entire study
- Pinned images:** all flagged images in the entire study.

- Select a print configuration from between those set during installation (max 4).

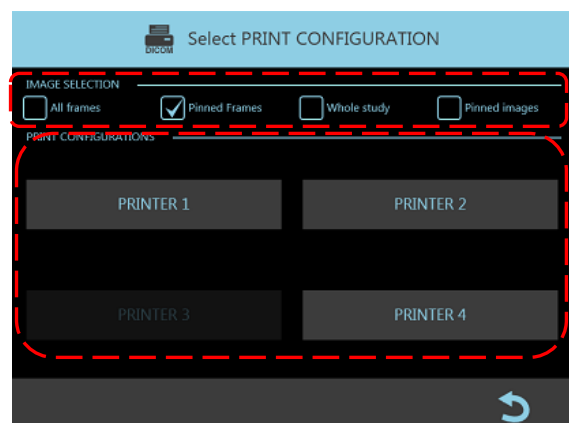

A message appears, telling you that the images are being sent to the transmission queue (Spooler):
“**Preparing to print...**”:

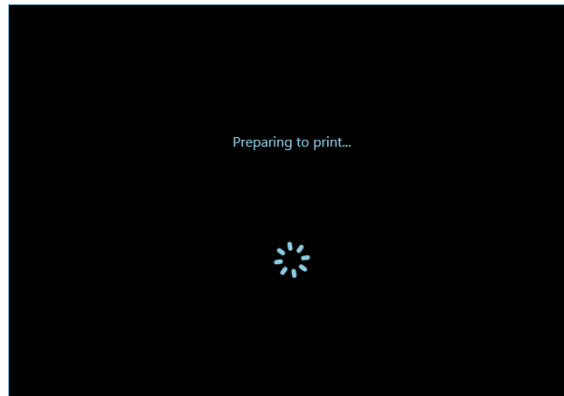

Note: *If the images in the study are displayed in OVERVIEW mode, the procedure for sending these to the STORE DICOM device is the same as that indicated at points 2) and 3) above.*

6.5.3 DICOM SPOOLER

The DICOM function explained earlier sends images to the DICOM SPOOLER module, responsible for managing the DICOM network and transmission.

As each image reaches the DICOM SPOOLER, it is added to the transmission queue and then sent to the relevant device as soon as possible; once printed, it is then deleted from the print queue.

You can access the DICOM SPOOLER menu from the Study List by touching this key:

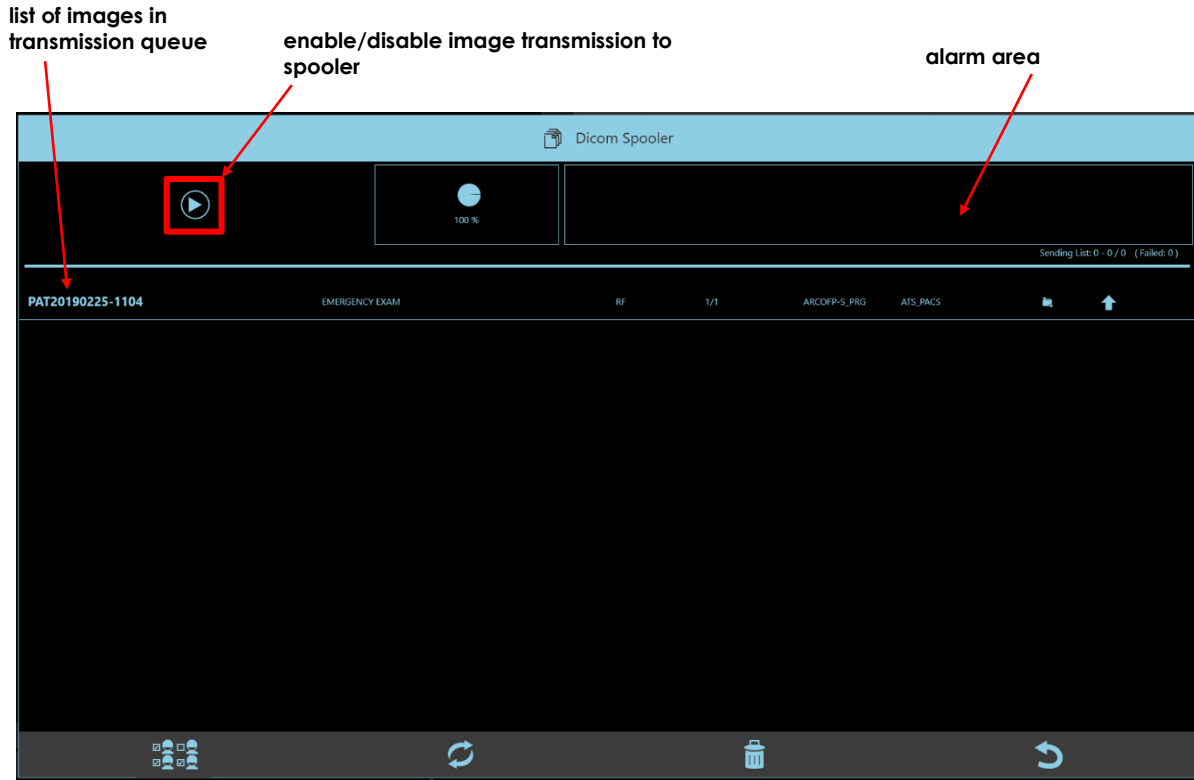

The button to open the function has the additional function of **showing the spooler status**. This can be, according to the color:



The status of each image in the transmission queue is shown in the highlighted column in this figure:

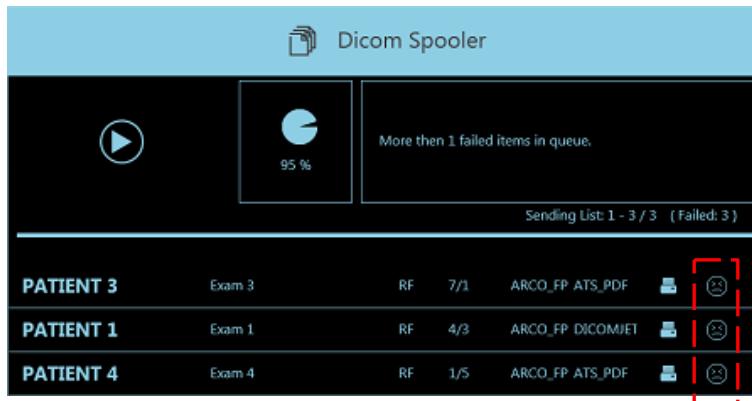



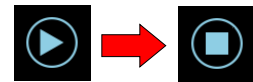

Image status	
	Being sent
	Queued, waiting to be sent
	Send error File creation error
	File deletion error after image has been sent

To manage any images remaining in the transmission queue, use this command:



You can now:

- **Select all the images** in the queue with this command:
- Make a **new transmission request** for the selected images using this command:
- **Delete** the selected images using this command:
- **Return to the Study List** using this command:



Use this command to restore the Spooler to normal operation:

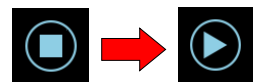

6.6 SAVING IMAGES TO USB DEVICE

The EM equipment lets you save images in DICOM format to a USB pen-drive:

- from the Study List frame
- from the Image Processing frame
- Insert a USB pen-drive in one of the two USB connectors on the equipment:



From the Study List frame, you can save:

- 1) one or more selected studies:
 - select the **USB** command in the Image Report menu:



USB Command

Open Image Report menu

From the Image Processing frame, you can save:

- 2) the selected images:
 - select the **USB** command in the Image Report menu:

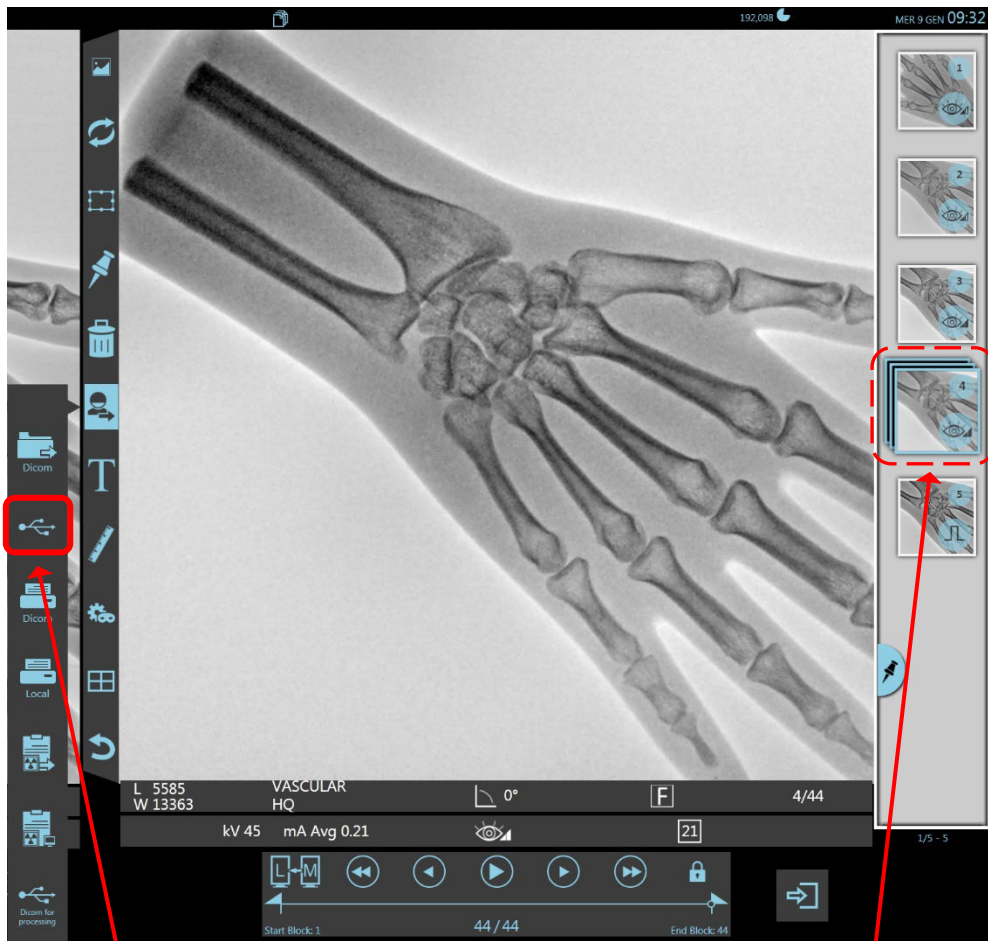

USB Command

SELECTED IMAGES SEQUENCE

- In both cases the Export frame appears:

Select images to be saved. Choose between: current image, whole study, pinned images.

Enable/disable the function to export images and anonymize patient data.

Select the storage device.

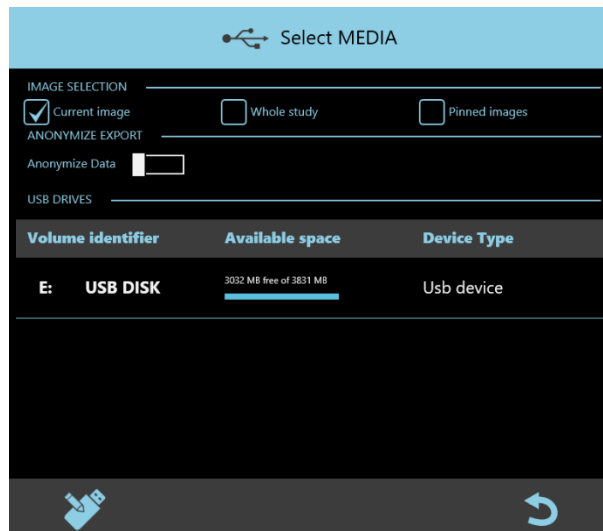

- You can now start copying the files by touching:

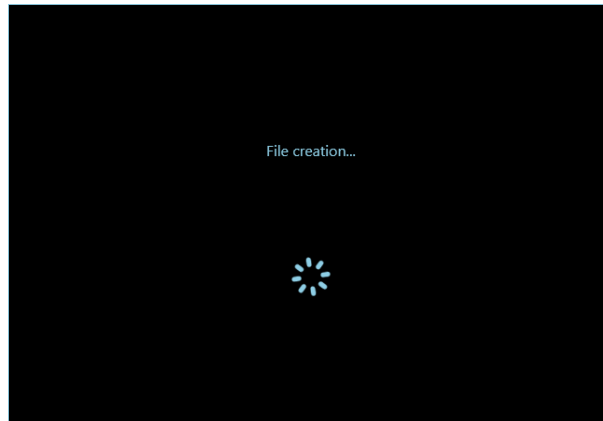

- Once the files have been copied, you can remove the USB drive.

Note: *it is required an appropriate DICOM viewer software to consult these images.*

6.7 RADIATION DOSE STRUCTURED REPORT (R.D.S.R.) (OPTIONAL)

R.D.S.R. function lets you send information about the X-ray dose received by a patient during each study to a DICOM terminal.
The data can be sent automatically, manually or viewed on your monitor.

Automatic transmission of these data can be set up during installation. As a result, the dose report will be sent automatically as soon as the study is closed.

It is, however, possible to send the dose information by pressing the relevant key shown next to this:



RDSR command

Open Image Report menu

Press this button to view more details about the X-ray dose reports on the monitor



The following page appears, with the following divisions:

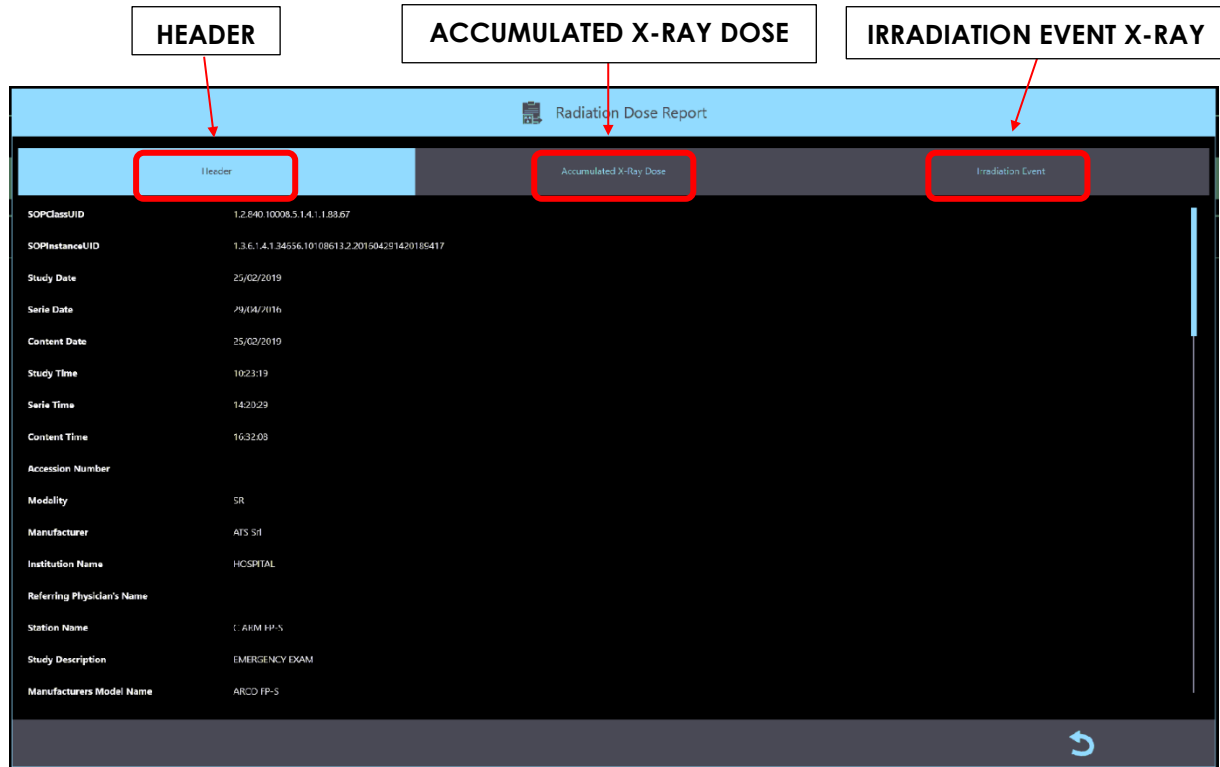

- HEADER = shows general details about the study
- ACCUMULATED X-RAY DOSE = shows the dose parameters accumulated during the study
- IRRADIATION EVENT X-RAY = shows X-ray exposure and dose parameters for each single X-ray emission

6.8 QUERY / RETRIEVE (OPTIONAL)

The DICOM QUERY / RETRIEVE functions let you view digital images generated by other image diagnostics programs on the equipment (e.g. CT, MR, ECHO, etc.). This is useful, for instance, when comparing acquired images with those in the hospital archive for the same patient.

The QUERY function searches for all the studies concerning a given patient in the hospital archive. This may be done by using these parameters: PATIENT NAME or PATIENT ID. All the results that satisfy the search conditions are then listed on the screen.

After selecting those of interest, use the RETRIEVE function to copy the selected study (or studies) on the local disk.

The Query/Retrieve functions are found in the Study List, in the QUERY / RETRIEVE LIST frame, accessed with this command:



Select the **QR SERVER** you want to use to find the studies (if more than one server is foreseen):

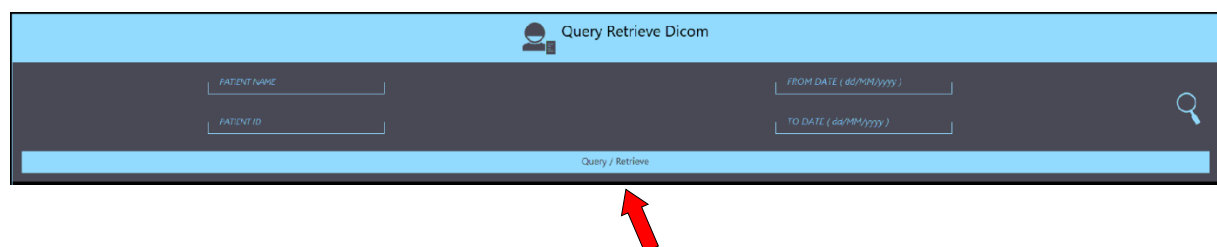

- Enter the key words to search for the study (or studies). These can be simply: the PATIENT NAME, the PATIENT ID, or a combination of both.



- Now use the **QUERY** key to display a list of all corresponding studies.

QUERY command



List of patients satisfying search

Now it is possible:

- **Manually select several studies** in the list using this command:
- **Return to the Study List** using this command:
- Use the **Retrieve Study** key to start transfer from the hospital archive (QR server) to the local disk on the EM equipment. The received study will appear in the QUERY / RETRIEVE LIST frame: double-click on it to consult its images.



The Query / Retrieve option includes a tested and validated program called **ETIAM Viewer**, that allows the visualization of images present in the imported studies. Its user manual (in English language, only) can be found together with all the other manuals on the CD supplied with the EM equipment.

Note: this option is only available at the sale moment. It cannot be installed in a second time.

6.9 CHANGING THE USER PASSWORD

Login passwords are only valid for 90 days. After this time, the system disables a user until the password is updated.

If a password is no longer valid, the following message appears during the Login process:

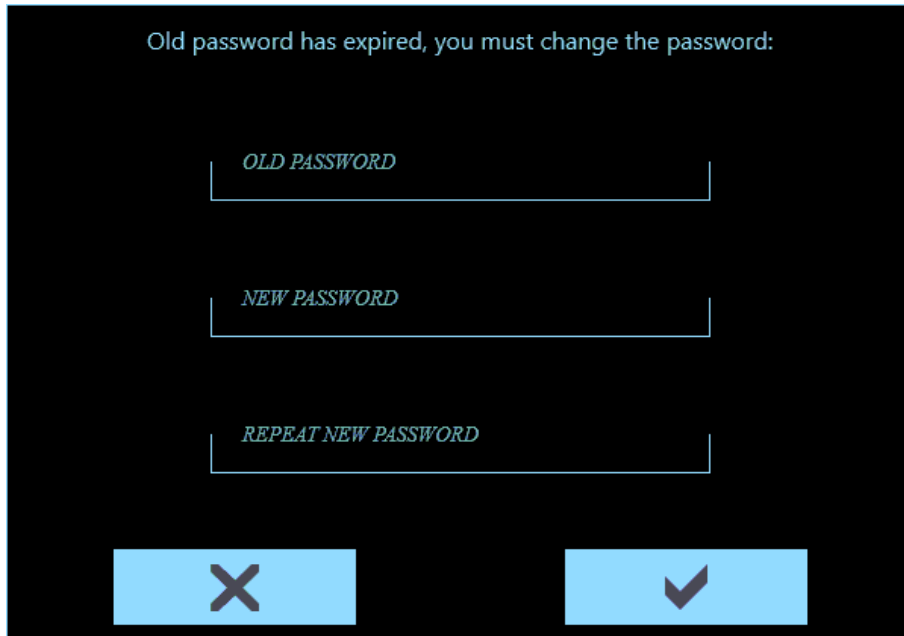

Old password has expired, you must change the password:

OLD PASSWORD

NEW PASSWORD

REPEAT NEW PASSWORD

X

✓

- To change the password, enter your old password and then a new one (twice); confirm with the **confirm** command.

6.10 ANATOMICAL EXAM SETUP

The equipment is configured with the default exams listed in *paragraph 2.2.5.1, Part 2 of the present manual*.

When selecting the exam on the Control Panel, the main acquisition and image processing parameters will be automatically set to suit the specific exam.

In case you need to add further exams to the default exams, it is necessary to access to the **Exam Setup menu with Administrator** rights (see *paragraph 4.4, Part 2 of the Technical Manual*).

6.11 SOFTWARE GLITCHES THAT CAN BE RESTORED BY THE OPERATOR

Standard **EN 60601-2-43** requires that it be possible for the user to restore the system (even partial functioning) in the event of a software malfunction.

The procedure is described in detail in the **Emergency manual** provided with the system.

There are two basic scenarios:

- 1) **The application freezes** (hang up): the device does not respond to any command
- 2) **The application closes** (crash): the working frames close and the monitor displays the splash screen of the program initialization.

⇒ **In the first instance (hang up):**

You need to turn off and turn on again the equipment.

- Switch the monitor unit off by turning the key to "OFF" (0).



- Wait for about **10 seconds**.

- Turn the equipment back on by turning the key to "ON" (I).



⇒ **In the second case (crash) the system automatically restarts the application, and the LOGIN page appears after the initialization phase.**

Note: in both cases, the equipment will be ready for use in about **1 minute and 30 seconds**.

6.12 CONNECTION OF AN AUXILIARY MONITOR

The equipment allows for the connection of an external monitor (not supplied with the device) via the **HDMI** socket.

The connection socket can be found on the right side of the equipment.



AUXILIARY MONITOR SOCKET (HDMI)

Note: *If you are planning to use the additional monitor for diagnostics, please make sure that the chosen monitor is a medical device type which is appropriate for this use.*

We recommend to use the same monitor model as the one already used on the EM equipment as an auxiliary monitor.

If you use another monitor type, please make sure that it is compatible with the EM equipment, that it has the **CE marking** and that it complies with the **IEC 60601-1** or the **IEC 60950** standard (in the latter case you will have to use an **IEC 60601-1 compliant** insulating device between monitor and power supply connection).

6.13 LOCAL PRINTER (OPTIONAL)

The equipment can be supplied with a digital, medical black and white printer. The printer is configured and installed by the equipment manufacturer.

Below you will find a list of available commands.

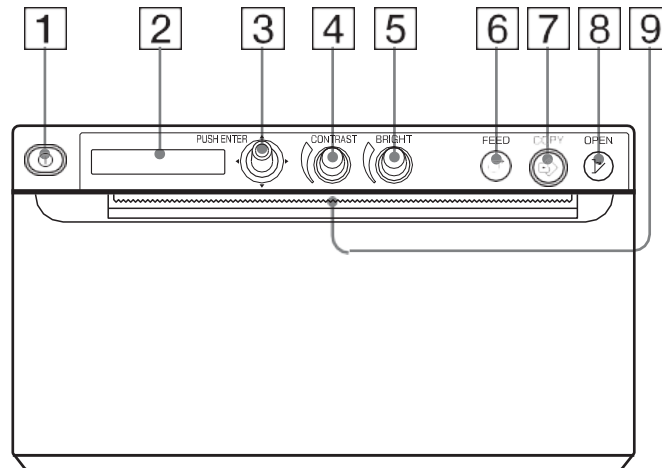

1. ON / OFF button.
2. Interface display
3. MENU lever: use to navigate within the printer menu.
4. CONTRAST control: adjust the contrast of the printouts.
5. BRIGHT control: adjust the brightness of the printouts.
6. FEED button: use to feed with paper. While a print job is in progress, press to cancel the print job.
7. COPY button: Press to print another copy of the previous printout.
8. OPEN button: Press to open the front door panel of the printer.
9. Automatic paper cutter.

Note: To prevent printouts from fading or changing color, store them in a cool, dry location where the temperature is not higher than 30 °C (86 °F), where they are not exposed to direct sunlight and avoiding any contact with liquids (even volatile ones).

6.13.1 LOADING THE PAPER

In case no paper is loaded when turning on the printer, the back light on the LCD display lights up in orange and the message "EMPTY" is displayed.

Use only the paper types **Sony UP-110S** (normal) or **110HD** (high density) or **110HG** (high gloss).

The process for loading paper is as follows:

- Press the OPEN button (8) to open the door panel.

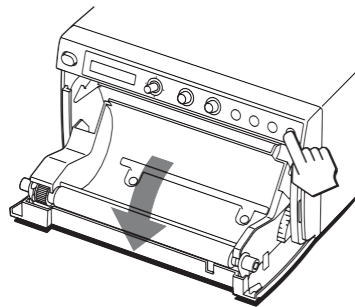

- Remove the label from the leading edge of the paper, pull out about 15 - 20 cm of the paper, then place the roll in the paper tray.

Note: Handle the paper with care and avoid touching or soiling the print surface so as not to deteriorate the quality of the printed images.

- Load the paper with the print surface (thermosensitive side) facing upwards. Printing is not possible on the other surface.

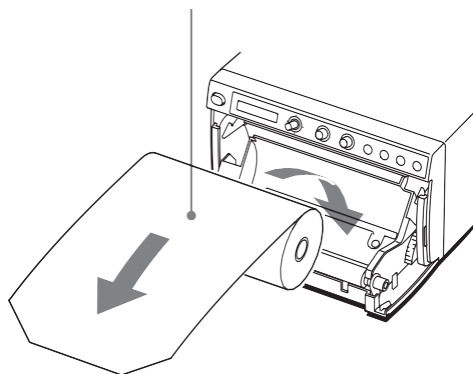

- Make sure that the paper is correctly aligned as it may cause a jam otherwise.

Note: for other maintenance operations or additional information please refer to the printer manual which is supplied with the equipment.