



Technical Manual



code 95 80 012

MAIN CONTENTS

PART 0 : PREFACE

PART 1 : GENERAL DESCRIPTION

PART 2 : INSTALLATION

PART 3 : ACCEPTANCE

PART 4 : ADJUSTMENTS

PART 5 : MAINTENANCE

Technical Manual

Date of issue 01/03/2021

Revised on 21/03/2022

Software release: 2.5.x.x



ATTENTION:

Read all the enclosed documents before using the EM equipment.

This TECHNICAL MANUAL is only considered complete when preceded by the document called the PREFACE.

Each part of this Technical Manual is preceded by a list of contents indicating the latest edition of each chapter. This is a translation of the Italian text, which prevails in case of doubts.

Part 1: GENERAL DESCRIPTION

CONTENTS

CONTENTS	pages	rev.	Date
CONTENTS	I-1	0	01/03/21
1 DESCRIPTION OF THE ELECTRICAL MEDICAL EQUIPMENT	1.1 - 1.25	0	01/03/21
1.1 Composition of the EM equipment			
1.1.1 Stand			
1.2 Applications and modes			
1.3 Safety			
1.3.1 Introduction			
1.3.2 Safety procedures			
1.3.2.1 Mechanical safety			
1.3.2.2 Electrical safety			
1.3.2.3 Equipotential earth connector			
1.3.2.4 Laser radiation			
1.3.2.5 Protection against ionizing irradiation			
1.3.2.6 Contra-indications on using the EM equipment			
1.3.3 Emergency procedures			
1.3.3.1 Emergency buttons			
1.3.3.2 Software glitches			
1.3.3.3 System failure			
1.3.4 Residual risks			
1.3.5 Scrapping the EM equipment			
1.3.6 Warnings			
1.3.6.1 Symbols used			
1.3.6.2 Status and alarm messages on the control panel			
1.3.7 Manufacturer's guidelines and declaration			
1.3.7.1 Electromagnetic emissions			
1.3.7.2 Electromagnetic immunity			
1.3.7.3 Recommended separation distances			
2 TECHNICAL DATA	2.1 - 2.15	0	01/03/21
2.1 Device Class			
2.2 Technical characteristics			
2.2.1 Mechanical/electrical data			
2.2.2 Imaging system			
2.2.3 Exposure modes			
2.3 Fuses			
2.4 Overall dimensions and weights			
2.5 Focal spot position			
2.6 Fluoroscopy mA curves			
2.7 Digital radiography (snapshot) exposure mA curves			
3 STORAGE AND HANDLING	3.1	0	01/03/21
3.1 Packaging			
3.2 Storage			

1 DESCRIPTION OF THE ELECTRICAL MEDICAL EQUIPMENT

1.1 COMPOSITION OF THE EM EQUIPMENT

- 1 Stand
- 2 X-Ray footswitch
- 3 Remote control

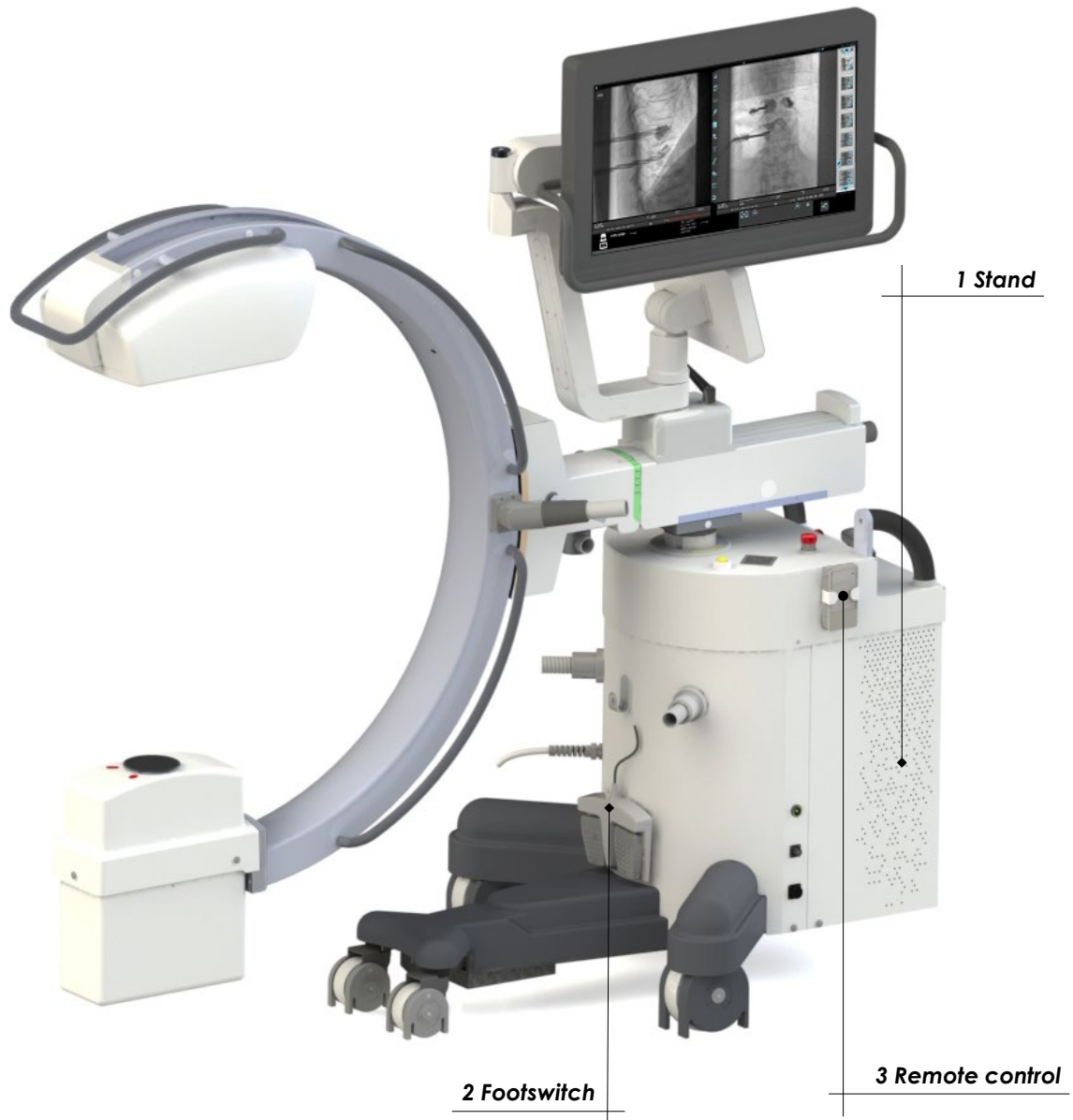

1.1.1 STAND

- 1 Control Panel
- 2 Touchscreen monitor for image display during X-ray emission and the last image acquired (LIH), for display and processing of the images saved on the hard disk.
- 3 X-ray monoblock
- 4 X-ray collimator
- 5 Flat panel detector
- 6 Base unit, containing power supply group and control unit for the equipment
- 7 Key for powering on / off the device
- 8 NFC reader (optional)
- 9 C-arm orbiting grips
- 10 C-arm orbiting brake
- 11 C-arm rotation brake
- 12 Longitudinal C-arm movement brake
- 13 Longitudinal C-arm movement handle
- 14 "Wig-wag" angle brake
- 15 Guide knob ($\pm 90^\circ$) for rear wheels and stand parking brake control
- 16 Support handles for moving the stand
- 17 C-arm column Up/Down button
- 18 Monitor support arm
- 19 Monitor support brake
- 20 Monitor swivel brake
- 21 Monitor height adjustment brake
- 22 X-ray command button
- 23 Emergency stop buttons (column motor)
- 24 Emergency stop button for the entire EM equipment
- 25 Footswitch cable connector
- 26 Injector connector
- 27 Equipotential earth connector
- 28 X-ray emission warning light / Remote control receiver
- 29 Laser light localizers (optional)
- 30 Dose Area Product (DAP, *optional*)
- 31 Anti-scatter grid
- 32 USB sockets for export of stored images
- 33 Connector for Ethernet network cable (DICOM)
- 34 Video connector for auxiliary monitor (HDMI)
- 35 Support for putting away cables after operation
- 36 Infrared remote control
- 37 General circuit breaker
- 38 EM equipment power supply cable

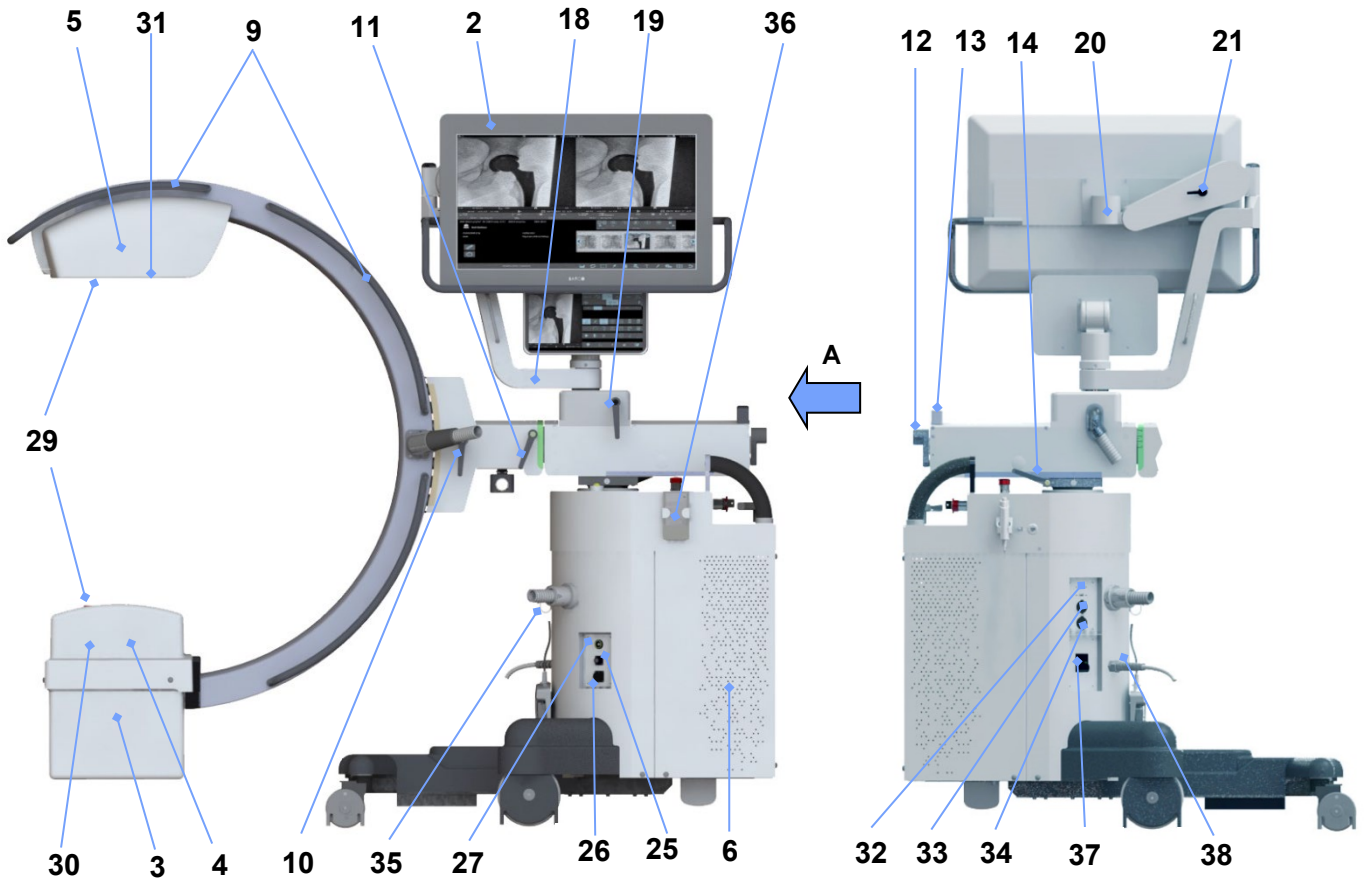
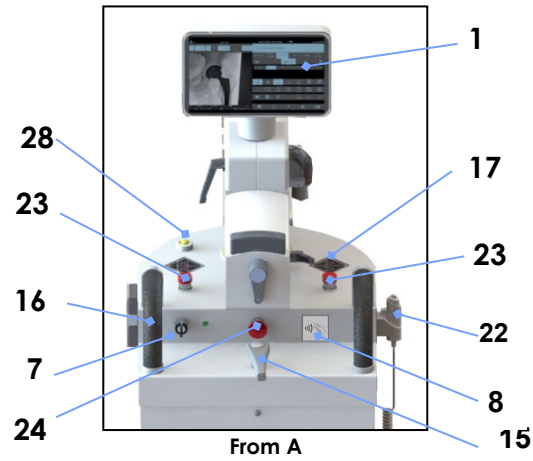

1.2 APPLICATIONS AND MODES

The EM equipment lets you acquire images in the following modes:

- **Low Dose** Fluoroscopy
- **High Quality** Fluoroscopy
- **Digital radiography** (Snapshot)
- Fluoroscopy in **Road Mapping** mode (optional)
- Fluoroscopy in **DSA** mode (optional)

See the User Manual for a description of each function.

See the "Technical Data" chapter below for full details of the technical data and characteristics.

1.3 SAFETY

1.3.1 INTRODUCTION

The EM equipment must be used solely in accordance with the safety instructions contained in this manual and in accordance with local regulations. It must never be used for purposes other than those for which it is intended.

Warning:



The manufacturer can only be held liable for the safety of its products if serviced and repaired by the manufacturer or by suitably trained and qualified personnel. The manufacturer holds regular training courses for technicians, fitters and maintenance workers at its head offices for this purpose.



The manufacturer cannot be held liable for any malfunction, loss or danger arising from improper use of the EM equipment or from non-observance of the maintenance instructions.



The organization responsible for the EM equipment is responsible for making sure that it is only and exclusively used by suitably trained and qualified operators.



The EM equipment must only be used by personnel with proper knowledge of protection against ionizing radiation and full training in the use of X-ray equipment.



The EM equipment must always be manned when switched on.



The equipment must EM not be used if there are any electrical, mechanical or radiological failures. Likewise, it must not be used in the event of a faulty alarm or signal.



Prior authorization must be obtained in writing from the manufacturer before making any modifications to this equipment or its safety system.



Never remove any parts or covers, as this could compromise the EM equipment's electromagnetic compatibility.



If you wish to use the equipment in combination with other devices, components or modules whose compatibility is not certain, you must make sure that there are no risks for patients or operators. Consult the manufacturer of the device in question or an expert.



As with any technical apparatus, the EM equipment must be used in a proper manner and receive regular checks and maintenance as specified in the "Maintenance" section of this manual.



The monoblock may reach a temperature close to 60 °C after prolonged use. Do not touch the monoblock or move it near the patient. When not in use, remove the sterile covers to help the monoblock cool down.



The cover panels must be cleaned following the instructions described in *Chapter 5, Maintenance of the User Manual*.
Moreover, the device must be installed far enough from objects that could obstruct the air to come out.



Never use corrosive substances (such as sodium hypochlorite, commonly known as bleach) to clean and disinfect the EM equipment.



The quality of the equipment may deteriorate after 10 years of use.
You must check the mechanical integrity of the equipment, the electrical safety devices and the image quality at the same X-ray dose on a regular basis.



The user must comply to the device basic maintenance and updating recommendations described in this manual, keeping the device up to date.

1.3.2 SAFETY PROCEDURES

1.3.2.1 MECHANICAL SAFETY

Warning:



Always apply the parking brakes after positioning the EM equipment.



Only use the special steering handles to move the EM equipment.



Avoid knocks or hitting any obstacles.



Never remove the guards unless for the maintenance operations expressly foreseen by and described in this manual.

1.3.2.2 ELECTRICAL SAFETY

Warning:



Never use the EM equipment in potentially explosive environments, e.g. in the presence of explosive gas or vapor (such as some anesthetics).



Never use the EM equipment in oxygen-rich environments.



Unplug the EM equipment from the mains before cleaning, disinfecting and sterilizing it.



Cleaning products and disinfectants can form explosive gas mixtures. Therefore, only use products that comply with the relevant safety regulations.



Take care not to spill conducting liquids on the EM equipment as these could infiltrate and so damage the equipment making it unsafe to use.



Protection against electric shock is provided by an earth connection (EM equipment, class I).

Make sure that the electrical plant to which the EM equipment is connected is properly earthed in compliance with current laws and regulations.

Note: Note: *the system does not contain any patient applied parts.*



Always switch the equipment off after use:

Follow the shut-down procedure for the equipment; at the end of the procedure, turn the key switch OFF.



Only unplug at the mains after completely switching the EM equipment off using the key switch on the monitor unit.

If the power cable becomes damaged, carefully remove it (holding it by the plug) and contact Technical Service for details on how to replace it.

Replace with a new cable obtained from the manufacturer of the EM equipment.

1.3.2.3 EQUIPOTENTIAL EARTH CONNECTOR

For maximum patient and medical staff safety, the patient bed must be earthed using the equipotential earth connector on the stand.

Use a cable with a Multi-Contact POAG-K4 or POAG-K6 connector to connect this (see detail in figure below).



The equipotential earth connector **MUST NOT** be used for connection to the EARTH (GND).
PROTECTION for the EM equipment.

1.3.2.4 LASER RADIATION

In order to center the X-ray beam, the system uses laser light localizers (optional), class 1M, which are placed on the flat panel detector and on the X-ray monoblock.

LASER LOCALIZER <i>Consisting of 4 laser modules (Optional)</i> (optional)	
Class	1M
Laser diode power	< 5 mW
Optical output power	3.8 mW
Wavelength	635 nm
Laser light warning	



Never look directly at the laser beam through a lens.

Beware that the laser beam may be reflected by surgical instruments or other accessories used during an operation.

The warning sticker (see image) is placed on the outside of the detector housing, right next to both lasers.

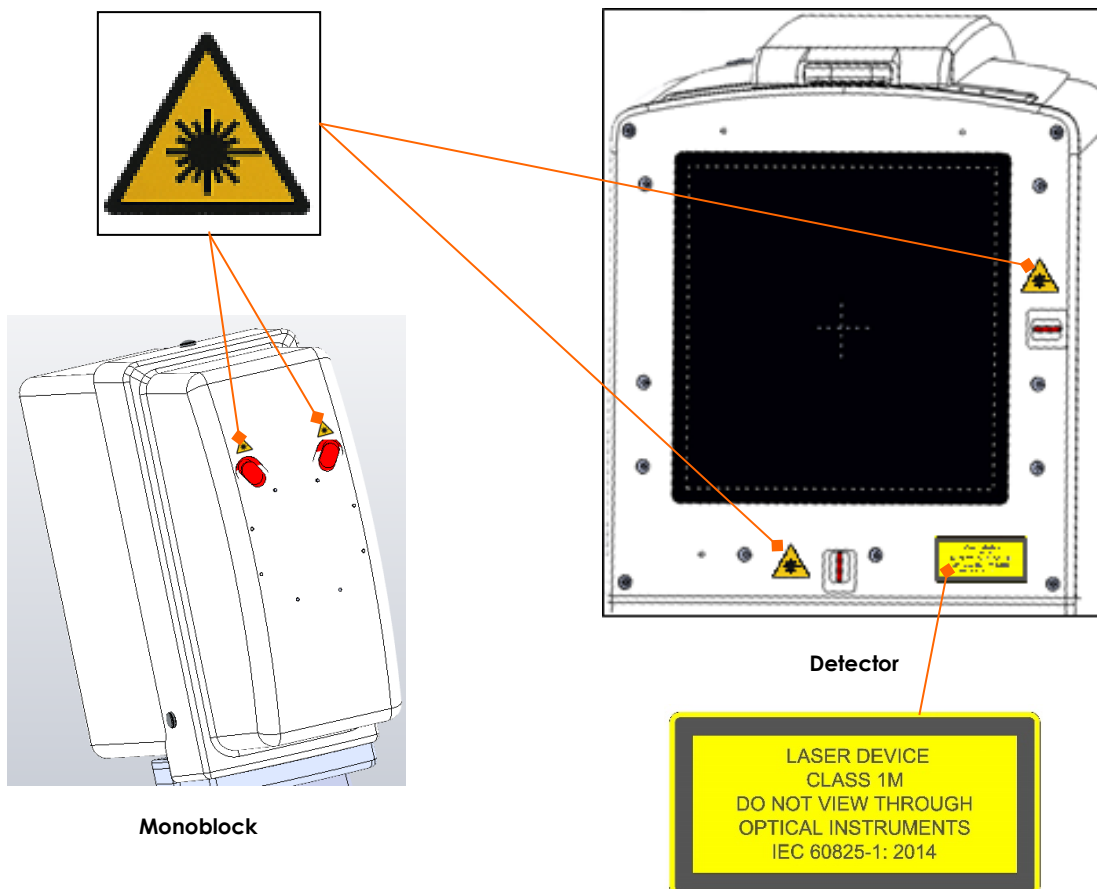

The laser diodes used are class 1M laser diodes (IEC standard 60825-1:2014).

1.3.2.5 PROTECTION AGAINST IONIZING RADIATION

The EM equipment emits ionizing radiation for medical purposes.

X-ray equipment can be harmful if not used in a proper manner.

These instructions **must therefore be read in full** and fully understood before the EM equipment can be used.

The use of this device involves two types of exposure to ionizing irradiation:

- ❖ occupational, for operators;
- ❖ diagnostic, for patients being scanned.

Even though the EM equipment provides a high standard of protection against X-rays, no occupational measure can guarantee total protection. The operator must, therefore, take all the necessary safety precautions to avoid the risk of exposure, to himself and others, arising from incorrect or excessive exposure to irradiation (see **Paragraph 1.3.2.5** below for further information about contra-indications on using the EM equipment).

All operators must receive suitable training and adopt all necessary safety measures to avoid the risk of harm.

The equipment is sold on the following condition (clause in the sale contract):

THE MANUFACTURER, ITS AGENTS AND REPRESENTATIVES CANNOT BE HELD LIABLE FOR ANY LOSS OR INJURY THAT MAY BE CAUSED BY IMPROPER USE OF THIS EM EQUIPMENT.



Before carrying out any exposure, make sure that all the necessary precautions against unnecessary irradiation have been taken.

During X-ray use, the personnel present in the X-ray room must observe all the radiation protection regulations in force.



Always provide patients with the necessary irradiation protection.



Use suitable personal radio-protective equipment. A radio-protective material equivalent to 0.35 mm of lead gives 99.95% protection against radiation of 50 kV and 94.5% protection against radiation of 100 kV.

Below are examples of such personal radio-protective equipment:



Protective aprons for operators



Protective aprons for patients



Head protection for operators



Thyroid protection for operators



Scrotum protection for male patients



Ovary protection for female patients



Distance is the best protection against irradiation: always keep as far away from the source of the X-rays and from the patient.

Use the manual switch at least 2 m from the X-ray beam to protect yourself further from the risk of dispersed radiation.

Accordingly, the coiled cable of the manual switch is about 4 meters long when fully extended.



Always set the smallest exposure field possible by closing the collimator shutters/iris. In fact, dispersed irradiation depends to a large extent on the volume of the irradiated object.



Avoid moving or remaining within the X-ray trajectory.



Keep the patient as far away from the X-ray source as possible to minimize the absorbed dose.

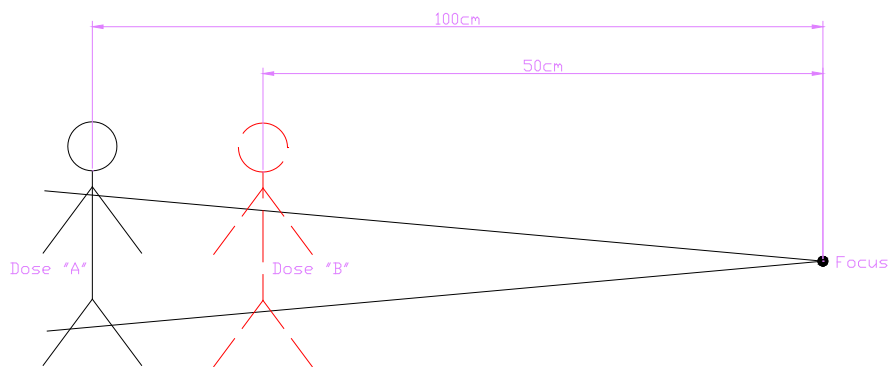

The dose values for the patient shown above (distance from focus = 100 cm and 50 cm) are:

$$dose" A" = \left(\frac{50cm}{100cm} \right)^2 \times dose" B"$$

For example, if a patient at a distance of 50 cm from the focus receives a dose of 10uGy (dose "B"), when that distance becomes 100 cm the received dose is:

$$dose" A" = \left(\frac{50cm}{100cm} \right)^2 \times 10Gy = 2,5uGy$$

Twice the distance results in a four-fold reduction in the received dose.



During every exposure, always make sure that the edge of the iris collimator is visible on the image: if it is not possible to collimate this correctly, request help from the Technical Service as there is the risk that the collimator is not working and remains open at an excessive value.



Make sure that there are no materials within the X-ray beam that could diminish the intensity of the X-rays and so lead to sub-standard images.
For example, the patient bed must conform with standard EN60601-2-54 table 203.104 (equivalent aluminum filtration less than 2.3mm).



Patient and operator irradiation must be kept as low as reasonably possible without compromising the benefits of the radiological procedure. If possible, always use the lowest dose and/or low rate pulsed fluoroscopy.



Deterministic effects can occur after prolonged exposure, when the X-ray dose received by a given organ or tissue exceeds a specific value (threshold dose).
The SKIN and the LENS are the tissues most affected during radio-diagnostics. The recommended threshold dose is **between 1Gy and 3Gy.**

1.3.2.6 CONTRA-INDICATIONS ON USING THE EM EQUIPMENT

The equipment should not be used if any of the following contra-indications exist (or are thought to exist):

- Acute skin burns, (patient).
- Acute hair loss, (patient).
- Chronic radiation injury (staff).

Note:

- *Special consideration must be given to the protection of the embryo or fetus during radiological examination or treatment of women known to be pregnant.*
- *Sensitive body organs (e.g., lens of eye, gonads) must be shielded whenever they are likely to be exposed to the ionizing radiation.*

1.3.3 EMERGENCY PROCEDURES

1.3.3.1 EMERGENCY BUTTONS



If the equipment suddenly malfunctions, use one of the **emergency buttons** (1 on the front part of the monitor station and 2 on the upper part of the stand), as shown by the arrows in the figures below:

- The central button (1) switches the entire EM equipment off.
- The two lateral emergency-stop buttons (2) ONLY stop the motorized movement of the column.

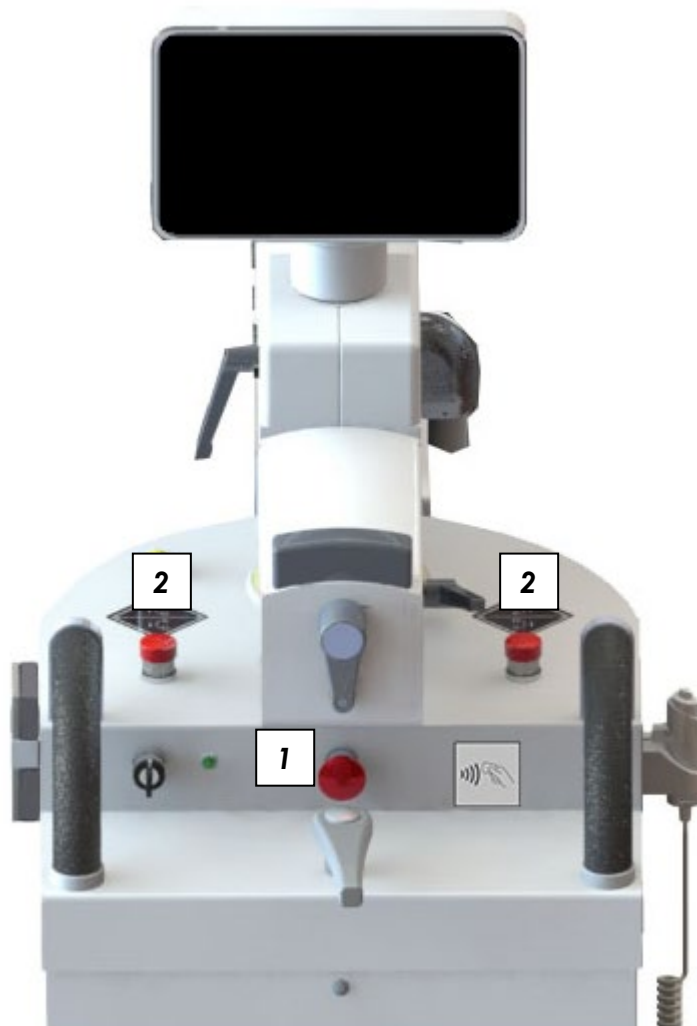

1.3.3.2 SOFTWARE GLITCHES WHICH CAN BE RESTORED BY THE OPERATOR

Standard **EN 60601-2-43** requires that it be possible for the user to restore the system (even partial functioning) in the event of a software malfunction.

The procedure is described in detail in the **Emergency manual** provided with the system.

There are two basic scenarios:

- 1) **The application freezes** (hang up): the device does not respond to any command
- 2) **The application closes** (crash): the working frames close.

⇒ **In the first instance (hang up):**

You need to reboot the equipment.

- Switch off by turning the key to "OFF" (0).
- Wait for about **10 seconds**.
- Turn the equipment back on by turning the key to "ON" (I).



⇒ **In the second instance (crash) the system automatically reboots the application and the LOGIN page appears after initializing.**

Note: in both cases, the equipment will be ready for use in about **1 minute and 30 seconds**.

1.3.3.3 SYSTEM FAILURE



The equipment is a highly complex medical device that in very rare cases can fail, just like any other device, despite of comprehensive tests and maintenance.

This may cause obstruction to the operational procedures.

Please, prepare an emergency plan and keep it ready in case the system cannot be recovered by the operator.

1.3.4 RESIDUAL RISKS

The EM equipment has been designed and built in full respect of the safety regulations. Nevertheless, there are still some risks involved in the use of this equipment if it is used incorrectly or the prescribed safety measures are faulty.

With regard to risks due to improper use of the EM equipment, see the instructions and recommendations above.

Note also that:

- Patients or operators may be harmed by uncontrolled movement of the stand due to excessively fast movement or steep surfaces.

- Never allow the equipment to pick up too much speed during movement.
- Never move the system on stairs or inclined surfaces with a gradient of more than 10°.
- When moving the system avoid all obstacles on the ground (e.g. cables and steps).



- The system has been tested for stability during movement on inclined surfaces (up to 10° and all other positions on slopes of up to 5°).

- Never use the stand on surfaces with an incline of more than 5° (or 10° during transit).
- Never try to move the equipment when its parking brake is engaged.



- In the case of uncontrolled movement of the C-arm, the mechanical structure may hit the patient or operators.

- Keep the movement of the C-arm under control at all times.



- The monoblock may overheat after continuous and prolonged use of the equipment.

- Never cover the surfaces of the monoblock with material that prevents heat dispersion (sterile sheets excepted).



- Inflammable gases may be ignited by electric arcs due to the operation of electrical components.

- Never use the equipment in the presence of anesthetics or other inflammable products.
- Check that there is a fire extinguisher in the room where the equipment is to be used and that it is working.



With regard to residual risks due to faults in the prescribed safety measures, note that:

- Protection against electric shocks is provided by means of an efficient earth system for all metal parts covering the equipment.

- The full earth circuit (for both internal and external parts and the mains supply) should therefore be checked for efficiency on a regular basis (see the "**Routine Maintenance**" schedule described in the Technical Manual).



- Hitting violently on the monitor might cause it to break.



- Avoid hitting the monitor with any objects.
- The screen is made of crystal and protected by a plastic layer which prevents, in case of hits, the scattering of fragments and the leakage of the jellylike liquid. If the screen is severely damaged, DO NOT TOUCH THE SCREEN WITH BARE HANDS; in case of accidental contact with the jellylike liquid which might have leaked, DO NOT TOUCH EYES OR MOUTH and wash the exposed body part immediately and thoroughly. If any reactions show, please consult a doctor, informing about the fact that it is related to jellylike liquid (liquid crystal) leaked out of an LCD panel.

- The column that raises the monoblock C-arm is motorized.



- If the motor responsible for moving the column is accidentally powered up, the operator should immediately push one of the emergency buttons.

- If smoke is seen or unusual noises are heard coming from the equipment:



- Switch the equipment off immediately and unplug at the mains.

- To control the residual risk of X-ray emission in the event of a system fault or incorrect adjustment, we recommend checking the dose level every day, immediately after switching the equipment on and before using it on patients (details of this test are provided in *Paragraph 1.8, Part 2 of the User Manual*).



- Never remove any parts or covers, as this could compromise the electromagnetic compatibility of the system.



- Portable and mobile radio communication devices may affect the efficiency of the device.



1.3.5 SCRAPPING THE EM EQUIPMENT

Once the EM equipment reaches the end of its useful life, dispose of all its components in accordance with the European Waste Electrical and Electronic Equipment Directive 2012/19/EU (WEEE).

Some parts of the equipment are built using hazardous materials, such as lead.

All flat batteries must be disposed of in accordance with European Directive 2006/66/EC and subsequent amendments



See Chapter 4 in Part 5 of this manual for full details.

1.3.6 WARNINGS

1.3.6.1 SYMBOLS USED

Symbols are used on the equipment and serial n° plate, as follows:



Caution: read the accompanying documents before use.

Note: This symbol, on the stand control panel, draws your attention to the absolute need to adhere to the instructions in this manual when using the equipment.



Laser light localizer present



Live parts



Potentially harmful physiological effects



Risk of crushed hands



X-ray focal point



Date of manufacture



Serial number



Manufacturer



Equipment to be disposed of in accordance with European Directive 2012/19/EC requirements ("WEEE" - Handling of Waste Electrical and Electronic Equipment)



Weight of the equipment in Kg.



Equipotential pole



ON (full system)
OFF (full system)



Movement prohibited (with C-arm raised)



Movement possible (transport position)

Note: The stand has been tested for stability during movement on inclined surfaces (up to 10° and all other positions on slopes of up to 5°.

- Never use the stand on surfaces with an incline of more than 5° (or 10° during transit).

- Never try to move the stand when its parking brake is engaged.















Raise C-arm
Lower C-arm



Wheels in straight position



Wheels positioned for side-ways movement

	Reference index (c-arm graded plaque)
	Reference index
	Brake ON
	Brake OFF
	X-ray emission indicator
	Low Dose fluoroscopy
	High-Quality Fluoroscopy
	X-ray emission command
	Ethernet socket
	USB socket
	NFC Reader (optional)
	HDMI OUT

1.3.6.2 STATUS AND ALARM MESSAGES ON THE CONTROL PANEL

The table below shows the list of messages foreseen by the equipment:

MESSAGE	MEANING	NOTES
READY	The equipment is ready to acquire images. You can now give the X-ray emission command.	
FLUOROSCOPY	X-ray emission in low dose fluoroscopy.	
HQ FLUOROSCOPY	X-ray emission in fluoroscopy mode for high quality images.	
FLUOROSCOPY DSA	X-ray emission in DSA fluoroscopy mode.	
RAD PREPARATION	Preparing for radiography.	
READY FOR RAD	RAD preparation completed.	
RAD	X-ray emission in radiography mode.	
PRE PEAK OPACIFICATION	The equipment is ready to run MAX OP function	
PEAK OPACIFICATION	MAX OPACIFICATION taking is running	
ROADMAPPING	ROAD MAPPING taking is running	
INSERT RX GRID	Insert the X-ray grid to suit the exam.	X-ray commands are inhibited.
REMOVE RX GRID	Remove the X-ray grid to suit the exam.	
RX SWITCH DISABLED	The X-ray emission commands ((footswitch and button) are disabled.	Press the relevant button on the control panel to enable them.
MAX FLUOROSCOPY TIME, RELEASE COMMAND RX	Fluoroscopy exposure has been interrupted on reaching the max accumulated fluoroscopy time-out (10').	Release the X-ray command and reset the alarm.
5 MINUTES FLURO	Fluoroscopy exposure has been interrupted on reaching the 5-minute fluoroscopy time-out without the warning being reset after 4 minutes and 30 seconds.	Release the X-ray command and reset the alarm.
MAX RADIOGRAPHY TIME	Radiography exposure has been interrupted on reaching the max admissible exposure time-out (970 milliseconds).	Check the quality of the image and repeat exposure if necessary.
MANUAL X-RAY STOP	The radiography command button has been released before exposure has ended.	Check the quality of the image and repeat exposure if necessary.
WAITING FOR FOCUS CHANGE	Wait for the equipment to change the focus.	
CI NOT CONNECTED	System fault.	Close application and restart. Call Technical Service if the alarm persists.
CI INITIALIZATION FAILED	System fault.	Close application and restart. Call Technical Service if the alarm persists.
WAITING FOR CONNECTION	System fault.	Close application and restart. Call Technical Service if the alarm persists.
NO X-RAY ENABLE FROM DETECTOR	Detector communication error.	Repeat exposure. Call Technical Service if the alarm persists.
ERROR SETTING X-RAY COLLIMATOR FILTERS	The X-ray collimator has been incorrectly set.	Select a different exam. Reboot the unit if the problem persists. Call Technical Service if the alarm persists after reboot.

MESSAGE	MEANING	NOTES
RX COLLIMATOR FAULT	The collimator fails to position itself correctly.	Check the position of the collimator. Reboot the unit if the problem persists. Call Technical Service if the alarm persists after reboot.
RX COLLIMATOR OFFLINE	The X-ray collimator is not connected or is faulty.	Call Technical Service.
CTBK OFFLINE	System fault.	Turn off and reboot the equipment. Call Technical Service if the alarm persists.
RECONNECTING CTBK...	The equipment modules are in the process of connecting.	Wait until completed.
UNABLE TO INITIALIZE CTBK FW: VERIFY ALARM LIST ON CONTROL PANEL	System fault. Press the alarm message shown on the control panel: a window appears listing the current alarms. (See page 2.11)	Follow the procedure indicated in this table to resolve the problem shown in the current alarm list. Call Technical Service if the alarm persists.
CTBK INITIALIZATION FAILED	System fault. Impossible to initialize CTBK. Verify the alarm messages list shown on the control panel.	Follow the procedure indicated in this table to resolve the problem shown in the current alarm list. Call Technical Service if the alarm persists.
CTBK HW FAULT	CTBK board fault.	Call Technical Service.
NEW EEPROM CTBK	A new EEPROM has been found by CTBK firmware.	Reboot the equipment. Call Technical Service if the alarm persists.
CTBK POWER SUPPLY +24V FAULT	Problem with the main controller power circuits in the equipment.	Turn off and reboot the equipment. Call Technical Service if the alarm persists.
COM-RX SIGNAL ACTIVE	The signal requesting COMMON acquisition (fluoroscopy and radiography) is already present on switching the equipment on.	Call Technical Service.
FLUOROSCOPY PEDAL CLOSED	Low Dose fluoroscopy pedal is already activated at the equipment starting.	Check whether the left pedal is pressed/blocked and release if necessary. If not, call Technical Service.
FLUOROSCOPY PEDAL HQ CLOSED	High Quality fluoroscopy pedal is already activated at the equipment starting.	Check whether the right pedal is pressed/blocked and release if necessary. If not, call Technical Service.
RAD PREP BUTTON CLOSED	Radiography preparation button is already activated at the equipment starting.	Check whether the X-ray button is pressed/blocked and release if necessary. If not, call Technical Service.
RAD BUTTON CLOSED	Radiography button is already activated at the equipment starting.	Check whether the X-ray button is pressed/blocked and release if necessary. If not, call Technical Service.

MESSAGE	MEANING	NOTES
FLUOROSCOPY BUTTON CLOSED	Low Dose fluoroscopy button is already activated at the equipment starting.	Check whether the X-ray button is pressed/blocked and release if necessary. If not, call Technical Service.
RX TUBE THERMAL SAFETY	The over-temperature thermal safety device in the X-ray monoblock has tripped. Radiography exposure is inhibited when the available heat units fall below the level required for the set exposure.	Wait for the X-ray monoblock to cool down.
RX TUBE TOO HOT	Tube Heat Unit available are not enough to satisfy exposure parameters set.	Wait for the X-ray monoblock to cool down.
LOW POWER	Monoblock or Anode Heat Unit are lower than 10%. Fluoroscopy acquisition mode is still available, but the equipment automatically decreases acquiring parameters in order to reduce monoblock heating.	If possible, wait for the X-ray monoblock to cool down.
ANODE STARTER FAULT	Problem in the rotating anode circuit.	Call Technical Service.
RX GENERATOR POWER SUPPLY FAULT	Problem in the X-ray generator circuits.	Call Technical Service.
LOW DOSE AT MAX kV	Insufficient dose level detected at max kV setting.	Check that the collimator is not completely closed. Check that the actual kV level correctly matches the size of the patient being scanned. Change the exam type if necessary.
RX GENERATOR NOT CONNECTED	X-ray generator communication error.	Turn off and reboot the equipment. Call Technical Service if the alarm persists.
FILAMENT FAULT	Problem with the circuit that switches on the X-ray tube filament.	Reset the alarm. Reboot the unit if the alarm persists. Call Technical Service if the alarm persists.
mA TOO LOW	The mA level is 1/3 lower than that foreseen.	Repeat exposure. Call Technical Service if the alarm persists.
mA TOO HIGH	The mA level is 1.5 higher than that foreseen.	Repeat exposure. Call Technical Service if the alarm persists.
kV UNBALANCED	The X-ray generator has detected incorrect voltage at the X-ray tube during exposure.	Reset the alarm. Check the connections between the CP1 connector of the S83 board mounted on the Monoblock and the CM2 connector of the S219 board of the inverter. Request help from the Technical Service if this alarm persists at the next exposure.

MESSAGE	MEANING	NOTES
MAX kV	The X-ray generator has detected too much voltage at the X-ray tube during exposure.	Reset the alarm. Check the connections between the CP1 connector of the S83 board mounted on the Monoblock and the CM2 connector of the S219 board of the inverter. Request help from the Technical Service if this alarm persists at the next exposure.
MIN kV	The X-ray generator has detected too little voltage at the X-ray tube during exposure.	Reset the alarm. Check the connections between the CP1 connector of the S83 board mounted on the Monoblock and the CM2 connector of the S219 board of the inverter. Request help from the Technical Service if this alarm persists at the next exposure.
MAX mA	The X-ray generator has detected too much current at the X-ray tube during exposure.	Reset the alarm. Call Technical Service if this alarm persists at the next exposure.
NO RX	The voltage at the X-ray tube fails to reach at least 75% the expected value during exposure.	Repeat exposure. Call Technical Service if the alarm persists.
DAP FAULT	Dose Area Product faulty.	Reboot the unit to reset the alarm. Call Technical Service if the alarm persists.
POSSIBLE DETERMINISTIC EFFECTS	The Kerma value accumulated during the study has exceeded the threshold (possibly set by the user) beyond which DETERMINISTIC EFFECTS could be detected.	Take care when continuing the procedure.
NO X-RAY DOSE SIGNAL	The X-ray dose signal from the acquisition system has not been detected.	Repeat exposure. Call Technical Service if the alarm persists.
X-RAY GENERATOR NOT CALIBRATED	X-ray generator not calibrated.	Call Technical Service to calibrate this.
MAX PREPARATION TIME	The radiography preparation command has been pressed for too long.	Release the PREP command.
HARDWARE ERROR DETECTOR	Detector fault.	Call Technical Service.
INJECTOR FAULT	Injector cannot activate	Check that the injector is ready and connected to the stand.
X-RAY ACTIVATION NOT FOUND	Lack of synchronism with the detector during exposure.	Repeat exposure. Reboot the equipment if the alarm persists. Call Technical Service if the alarm persists.
FAULTY BEAM SIGNAL	The inverter signals x-rays presence even if they have not been commanded.	Call Technical Service.
X-RAY WATCHDOG ACTIVED	The safety circuit of the x-ray commands has been activated: the x-ray emission is blocked.	Switch off and reboot the equipment. Call Technical Service if the alarm persists.

1.3.7 MANUFACTURER'S GUIDELINES AND DECLARATION



Never remove any parts or covers, as this could compromise the electromagnetic compatibility of the system.



Portable and mobile radio communication devices may affect the efficiency of the device.

1.3.7.1 ELECTROMAGNETIC EMISSIONS

Table 1

Manufacturer's guidelines and declaration - electromagnetic emissions		
In accordance with EN standard EN 60601-1-2 (4th edition), the system is intended for use in the electro-magnetic environment specified below. <u>The client or user of the system must ensure that it is used in such an environment.</u>		
Emissions test	Compliance	Electromagnetic environment - guidelines
RF emissions CISPR 11	Group 1	The system uses RF energy only for its internal functioning. Therefore, its RF emissions are very low and are not likely to cause any interference in nearby electronic equipment.
	Class A	The system is suitable for use in all establishments, excluding domestic establishments or those directly connected to the public low-voltage power supply network (mains) that supplies
Harmonic emissions EN 61000-3-2	Not applicable	Note: <i>In case the equipment is used in domestic environments (for which the CISPR 11 indicates CLASS B) it could be that the equipment does not provide adequate protection against radiofrequency interferences. The user will have to adopt attenuating measures such as repositioning or different orientation of the equipment in the environment.</i>
Voltage fluctuation / flicker emissions EN 61000-3-3	Not applicable	

1.3.7.2 ELECTROMAGNETIC IMMUNITY

Table 2

Manufacturer's guidelines and declaration - electromagnetic emissions			
<p>In accordance with EN standard EN 60601-1-2 (4th edition), the system is intended for use in the electro-magnetic environment specified below. The client or user of the system must ensure that it is used in such an environment.</p>			
Immunity test	Test level EN 60601-1-2	Compliance level	Electromagnetic environment - guidelines
Electro-static discharge (ESD) EN 61000-4-2	±8 kV contact ±15 kV air	±8 kV contact ±15 kV air	Hospital environment: Floors should be wood, concrete or ceramic tile. If floors are covered with synthetic material, the relative humidity should be at least 30%.
Radiated, radio-frequency, electromagnetic field IEC 61000-4-3	3V/m 80MHz to 2,7GHz	3V/m 80MHz to 2,7GHz	Portable and mobile RF communications equipment should be used no closer than 30 cm from any part of the system, including cables. <i>(see following paragraph 2.6.3).</i>
Electrical fast transient / burst EN 61000-4-4	±2kV for power lines ±1kV for input/output lines >3 m	±2kV for power lines ±1kV for input/output lines >3 m	Mains power quality should be that of a typical hospital environment.
Surge EN 61000-4-5	±1kV differential mode ±2kV common mode	±1kV differential mode ±2kV common mode	Mains power quality should be that of a typical hospital environment.
Immunity to conducted disturbances, induced by radio-frequency fields IEC 61000-4-6	3 V 150 kHz to 80 MHz 6V ISM frequencies	3 V 150 kHz to 80 MHz 6V ISM frequencies	Portable and mobile RF communications equipment should be used no closer than 30 cm from any part of the system, including cables. <i>(see following paragraph 2.6.3).</i>
Voltage dips, short interruptions and voltage variations on power supply input lines EN 61000-4-11	10 ms for 0% at 0°, 45°, 90°, 135°, 180°. 225°, 270°, 315° 20 ms for 0% at 0° 500 ms for 70% at 0° 5 s for 0%	10 ms for 0% at 0°, 45°, 90°, 135°, 180°. 225°, 270°, 315° 20 ms for 0% at 0° 500 ms for 70% at 0° 5 s for 0%	Mains power quality should be that of a typical industrial or hospital environment. We recommend fitting an UPS (uninterruptible power supply) if the user's system calls for continuous running even during power interruptions.
Power frequency magnetic field immunity (50/60Hz) EN 61000-4-8	30 A/m	30 A/m	If the monitor of the device shows signs of distortion in the images it will be necessary to position it further away from the source of the power frequency magnetic field or install a magnetic shield. The power frequency magnetic field must be measured in the new position so as to verify that the monitor is positioned far enough.

1.3.7.3 RECOMMENDED SEPARATION DISTANCES BETWEEN SYSTEM AND PORTABLE AND MOBILE RF COMMUNICATIONS EQUIPMENT

The system is intended for use in an electromagnetic environment in which radiated RF interference is controlled.

The client or user of the system can help prevent electromagnetic interference by maintaining a minimum distance between portable and mobile RF communications equipment (transmitters) and the system as recommended below, according to the maximum output power of the communications equipment.

Table 4

Test frequency (MHz)	Band (MHz)	Service	Modulation	Max power (W)	Distance (m)	Immunity level in test (V/m)
385	380 - 390	TETRA 400	Pulse modulation 18 Hz	1.8	0.3	27
450	430 - 470	GMRS 480 FRS 460	FM ~ 5 KHz deviation 1 KHz without	2	0.3	28
710	704 – 787	LTE Band 13, 17	Pulse modulation 217 Hz	0.2	0.3	9
745						
780						
810						
870	800 – 900	GSM 800/900 TETRA 800 IDEN 820 CDMA 850 LTE Band 5	Pulse modulation 18 Hz	2	0.3	28
930						
1720	1700–1990	GSM 1800CDMA 1900 GSM 1900 DECT LET Band 1, 3, 4, 25 UMTS	Pulse modulation 217 Hz	2	0.3	28
1845						
1970						
2450	2400-2570	Bluetooth, WLAN 802.11 b/g/n, RFID 2450, LET Band 7.	Pulse modulation 217 Hz	2	0.3	28
5240	5100-5800	WLAN 802.11 a/n	Pulse modulation 217 Hz	0.2	0.3	9
5500						
5785						

2 **TECHNICAL DATA**

2.1 **DEVICE CLASS**

Type of protection against electrical contacts:	Class I
Degree of protection against electrical contacts:	The system does not contain any patient applied parts
Degree of protection against water penetration:	Common equipment
Degree of safety in the presence of inflammable gases:	not suitable for use in the presence of inflammable gases
Operating conditions:	Continuous operation

2.2 **TECHNICAL CHARACTERISTICS**

2.2.1 MECHANICAL/ELECTRICAL DATA

C-ARM		
MECHANICAL DATA		
Motorized vertical stroke	- stroke: 450mm - speed: 1 cm/s	
Horizontal stroke	215 mm	
Wig-wag	± 12°	
Arc rotation around horizontal axis	± 275°	
C-arm sliding.	160°	
Focal spot / flat panel detector distance (S.I.D.)	FPD 3030	FPD 2121
	1080mm	1066mm
Flat panel detector / X-ray monoblock distance	808 mm (for models with FPD 2121) 821 mm (for models with FPD 3030)	
Arc depth	707 mm	
POWER SUPPLY		
Single-phase voltage	230 Vac ± 10%, 50Hz, 60 Hz	
	120 Vac ± 10%, 50Hz, 60 Hz	
Max consumption	- Fluoroscopy: 10 A (230 Vac) 16 A (120 Vac)	
	- Radiography: 22 A	
Line resistance	max 0.4 Ohms	
Connector	NEMA 5 - 20 A	
ENVIRONMENTAL CONDITIONS		
Storage	- Temperature: -10 to +55 °C	
	- Relative humidity: 20 - 70 %	
	- Pressure: 70 - 106 kPa	
Working	- Temperature 10 - 35 °C	
	- Relative humidity: 30 - 70 %	

X-RAY GENERATOR	
Code	IRI.37.203.001
Oscillation rate	40 kHz
Max voltage	120 kVp
Max current in pulsed fluoroscopy mode	50mA @ 100kV
Max current in continuous fluoroscopy mode	6mA @ 100kV
Current in radiography mode	50mA @ 100kV (0,1s)
Max current in radiography mode	100 mA
Max power for radiography	5kW (50mA @ 100kV 0,1s)

Note: for more details, see Paragraph 2.6 and 2.7 at the end of this Section.

X-RAY MONOBLOCK	
Model	I-40R 15 RF
Code	I01.01.138.001
Max power	20kW (200mA @ 100kV 0,1s)
Heat capacity	1020 kJ
Continuous heat dissipation (in air)	130W
Continuous heat dissipation (on C-arm)	150W
Total filtering	3mm Al _{eq} @ 70kV
Safety overload cut-out temperature	60°C ±5°C
Max charging time for X-ray monoblock in continuous fluoroscopy mode	60 min Duty cycle: 60 sec. ON – 60 sec. OFF @ 15i/s, 70 kV - 6 mA _{avg}
Compliance	EN 60601-1 and EN60601-2-28
Leakage Radiation	< 1 mGy/h @ 120kV-4mA continuous fluoro or 120kV-14400mAs Digital Rad

X-RAY TUBE	
Model	IAE RTM70H
Anode material	Rhenium/Tungsten/ Molybdenum
Focus	- Small focus: 0.3 mm - Large focus: 0.6 mm
Anode angle	10°
Anode heat capacity	225 kJ
Max anode heat dissipation	750 W
Nominal anode power	- Small focus: 6 kW - Large focus: 25 kW
Anode rotation	3000 rpm (50Hz) 3600 rpm (60Hz)

X-RAY COLLIMATOR with FPD 2121 ASI	
Model	R650 QDASM/010D + secondary collimator RS 2248
Square field (iris)	- Continuously adjustable aperture - Automatic adjustment to suit detector field - Manual control
Shutters	- Continuously adjustable aperture - Clockwise/anti-clockwise rotation, continuously adjustable - Manual control - Asymmetrical adjustable shutters
Max X-ray field	21 x 21 cm²
Additional X-ray beam filtering (4 possible conditions)	- No filter - 2mm Al - 1mmAl + 0,1mmCu - 1mmAl + 0,2mmCu

X-RAY COLLIMATOR with FPD 3030 ASI	
Model	R650 QDASM/010D
Square field (iris)	- Continuously adjustable aperture - Automatic adjustment to suit detector field - Manual control
Shutters	- Continuously adjustable aperture - Clockwise/anti-clockwise rotation, continuously adjustable - Manual control - Asymmetrical adjustable shutters
Max X-ray field	30 x 30 cm²
Additional X-ray beam filtering (4 possible conditions)	- No filter - 2mm Al - 1mmAl + 0,1mmCu - 1mmAl + 0,2mmCu

DOSE AREA PRODUCT METER (DAP) (optional)	
Model	KermaX plus (mod. 120-123c)
Power supply	DC: 12 - 29V (max 50mA)
Useful Area Diameter	93 mm
Sensitivity	1mGy x cm ²

LASER LOCALIZER Consisting of 4 laser modules (Optional) (optional)	
Model	ML635L in class 1M
Class	1M
Laser diode power	< 5 mW
Optical output power	3.8 mW
Wavelength	635 nm
Laser light warning	

2.2.2 IMAGING SYSTEM

FLAT PANEL DETECTOR		
Model	PaxScan 2121DXV	
FPD Matrix	1024 x 1024 pixel	
Sensitive area	<p>FLUOROSCOPY Nominal field= 205mm x 205mm (1004 x 1004 pixel) Zoom 1= 160mm x 160mm (780 x 780 pixel) Zoom 2= 120mm x 120mm (585 x 585 pixel)</p> <p>DIGITAL RADIOGRAPHY Nominal field= 205mm x 205mm (1004 x 1004 pixel)</p>	
Technology	Amorphous Silicon matrix	
Pixel size	205 µm	
Max frame rate	30 frame/s	
Resolution (limit)	2.43 lp/mm	
DQE @ 2 µ Gy, RQA5	0 lp/mm	80 %
	1.0 lp/mm	65 %
	2.0 lp/mm	40 %
MTF	IEC 1.0 lp/mm	55 %
	IEC 2.0 lp/mm	22 %
A/D conversion	16 bits	
Power supply	24 VDC - 12W	
Max dimensions	241mm x 241mm x 53.7mm	
Weight	3.2 kg	
Cooling	Passive	
Ambient Temperature	- Working: 15° - 58° - Storage: -20° - 70°	
Filtering of detector protective element	0.4 mm Al _{eq}	

FLAT PANEL DETECTOR		
Model	PaxScan 3030DXV	
FPD Matrix	1536 x 1536 pixel	
Sensitive area	<p style="text-align: center;">FLUOROSCOPY</p> <p style="text-align: center;">Nominal field= 294mm x 294mm (1516 x 1516 pixel) Zoom 1=209mm x 209mm (1082 x 1082 pixel) Zoom 2= 159mm x 159mm (824 x 824 pixel)</p> <p style="text-align: center;">DIGITAL RADIOGRAPHY</p> <p style="text-align: center;">Nominal field= 294mm x 294mm (1516 x 1516 pixel)</p>	
Technology	Amorphous Silicon matrix	
Pixel size	194 µm	
Max frame rate	30 frame/s	
Resolution (limit)	2.58 lp/mm	
DQE @ 2 µ Gy, RQA5	0 lp/mm	80 %
	1.0 lp/mm	65 %
	2.0 lp/mm	44 %
MTF	IEC 1.0 lp/mm	55 %
	IEC 2.0 lp/mm	23 %
	IEC 2.58 lp/mm (Nyquist Frequency)	15 %
A/D conversion	16 bits	
Power supply	24 VDC - 15W	
Max dimensions	338mm x 328mm x 57.6mm	
Weight	5.6 kg	
Cooling	Passive	
Ambient Temperature	- Working: 15° - 58° - Storage: -20° - 70°	
Filtering of detector protective element	0.4 mm Al _{eq}	

ANTI-SCATTER GRID	
Manufacturer	JPI
Model	ACS
Dimensions	215 mm x 215 mm (with FPD 2121) 315 mm x 315 mm (with FPD 3030)
Interspace	Aluminum
Ratio	8:1
Shutters	80 lines/cm
Focal distance	100 cm
Attenuation ratio (expressed as 1/transmission of primary radiation =1/0.7)	1.42

TV MONITOR	
Model	GUP2762AMII-P
Technology	27" color LCD
Resolution	2560 x 1440 (4k)
Contrast ratio	1000:1
Brightness	350 cd/m ² (max)
Viewing angle	Vertical and horizontal 178°
Power supply	110-230 VAC
Max consumption	60 W
Dimensions	651 x 402 x 69 mm
Weight	11.8 Kg

CONTROL PANEL	
Model	MUIP-2112
Technology	LCD 12,5" color, Touch screen
Effective display area	276,5 mm x 157,5 mm
Resolution	1920 x 1080 pixel
Contrast ratio	Max 1000:1
Brightness	400 cd/m ² (typ)
Viewing angle	Vertical and horizontal: 80 °
Touch screen	P-Cap Multitouch 10-point (usable with surgical gloves)
Processor	CPU Intel Celeron N2930 (Quad core 1,83 Ghz, 2Mb cache)
SDRAM	4GB DDR3L 1333MHz RAM
Memory	32GB SATA onboard SSD
Ethernet	2 x Built-in Gigabit Ethernet LAN interfaces
USB	- 1 USB 2.0 port type A - 1 USB 3.0 port type A
Operating System	Microsoft: Windows 10 LTSB
Power supply	Range 12-24Vdc, nominal 19Vdc

VIDEO PROCESSOR	
CPU	Intel i7-8700 3,2GHz 6 core Coffee Lake
Operating System	WINDOWS 10 IoT Enterprise 2019 LTSC (ESD) ENG 64bit
Video board	PCI-e 16x ASUS Model ROG-STRIX-GTX1650-04G
Ethernet interface board	Intel Model: I210-T1
RAM	16GByte
Hard Disk	2 HARD DISKS SSD 512GB PCIe NVMe
Interface	<ul style="list-style-type: none"> - USB (for Windows compatible printer) - USB (for saving images to USB memory stick) - RJ45 (for DICOM 3 interface)
Acquisition	<ul style="list-style-type: none"> - Resolution matrix: 1516 x 1516 pixels (max) - Image depth: 16 bits - Speed: max 30 frames/second
Details of saved images on HD	<p><u>Detector 3030DXV:</u></p> <ul style="list-style-type: none"> - field 30 x 30 cm²: 1516 x 1516 pixels (1 - 8fps) 758 x 758 pixels (15 - 30fps) - field 21x21 cm²: 1082 x 1082 pixels - field 16x16 cm²: 824 x 824 pixels <p><u>Detector 2121DXV:</u></p> <ul style="list-style-type: none"> - field 21x21 cm²: 1004 x 1004 pixels - field 16x16 cm²: 780 x 780 pixels - field 12x12 cm²: 585 x 585 pixels <ul style="list-style-type: none"> - Grey scale depth: 16 bits unsigned - Little Indian byte order
Image processing in real time	<ul style="list-style-type: none"> - Reduction of quantum noise via recursive filter Motion sensitive - DRC (Dynamic Range Compression), digital process to optimize image and contrast latitude - Edge enhancement/reduction (sharp/smooth), with specific kernel settings (from 3 x 3 to 9 x 9 pixels). - Grey scale inversion (negative) - Horizontal image flip. - Digital image rotation (steps of 1°). - Automatic Gain Control (AGC): automatic control of the images Window and Level. - L.I.H (Last Image Hold): the last acquired image is saved in RAM. - DSA functions: * <ul style="list-style-type: none"> - Images subtraction - Max Opacification / Road Mapping

VIDEO PROCESSOR	
Post-processing functions	<ul style="list-style-type: none"> - Patient data entry - Cine-loop of acquired run - Contrast / Brightness control (W and L) - Edge enhancement/reduction (sharp/smooth), with specific kernel settings (from 3 x 3 to 9 x 9 pixels). - DRC (Dynamic Range Compression), digital process to optimize image and contrast latitude - Grey scale inversion (negative) - Multiframe display (max 6) - Electronic shutters - Virtual shutters - Angle/distance measurements - Text entry (free or fixed strings) - Printouts using Windows compatible printer - Saving of images to USB memory stick in DICOM format - DSA functions: * <ul style="list-style-type: none"> - Mask pick-up - Pixel Shift - Land marking - Catheter calibration
DICOM functions (*)	<ul style="list-style-type: none"> - Importing of studies to be performed from the "Worklist SCU" service - Sending of images via the "Store SCU" service - Sending of images to be printed via the "Print SCU" service - Management of studies via the "MPPS SCU" service - Confirmation of image storing via the "Storage Commitment SCU" service - Management of the patient dose via the "Dose Structured Report SCU" service - Request for images via the "Query / Retrieve SCU" service

(*) Optional

2.2.3 EXPOSURE MODES

For a full description of the exposure modes:

- **Low Dose** Fluoroscopy
- **High Quality** Fluoroscopy
- **Radiography**
- mAs table
- kV/mA correlation
- Dose information

see Paragraph 1.4 in Part 1 of the User Manual.

For a full description of the exposure modes:

- Roadmap
- DSA Fluoroscopy

see Paragraphs 4.1 and 4.2 in Part 2 of the User Manual.

2.3 FUSES

The power circuit of the EM equipment is protected by a magnetothermal circuit-breaker.

Simply reset the magnetothermal circuit-breaker if it trips.

If the magnetothermal circuit-breaker trips again immediately after resetting, the EM equipment is malfunctioning call Technical Service.

The EM equipment is completely cut off from the mains supply when the magnetothermal circuit-breaker trips (both electrical poles are separated).

The EM equipment can be supplied ready for a mains power supply of 230 or 120 Vac, with a specific circuit breaker as indicated in the following table:

Characteristics of the circuit breaker:

120 Vac Version	
Tripping type	Type D
Tripping current	16A
Number of poles	2
Tripping power	10kA
Nominal AC voltage	400V

230 Vac Version	
Tripping type	Type D
Tripping current	10A
Number of poles	2
Tripping power	10kA
Nominal AC voltage	400V



2.4 OVERALL DIMENSIONS AND WEIGHTS

Versions with **FPD 2121**

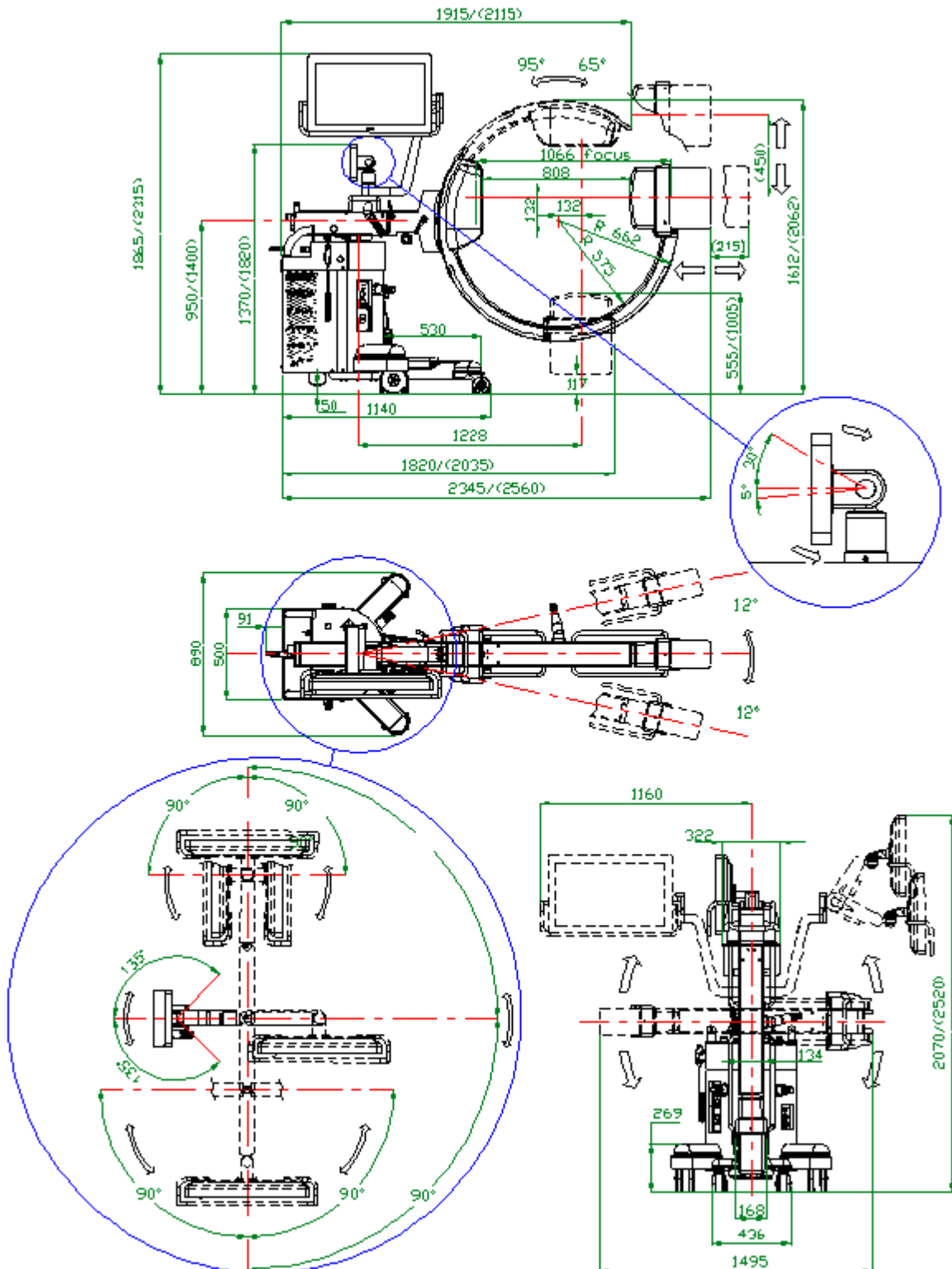

Note: Dimensions shown in mm

Weight: **310 kg**

Versions with **FPD 3030**

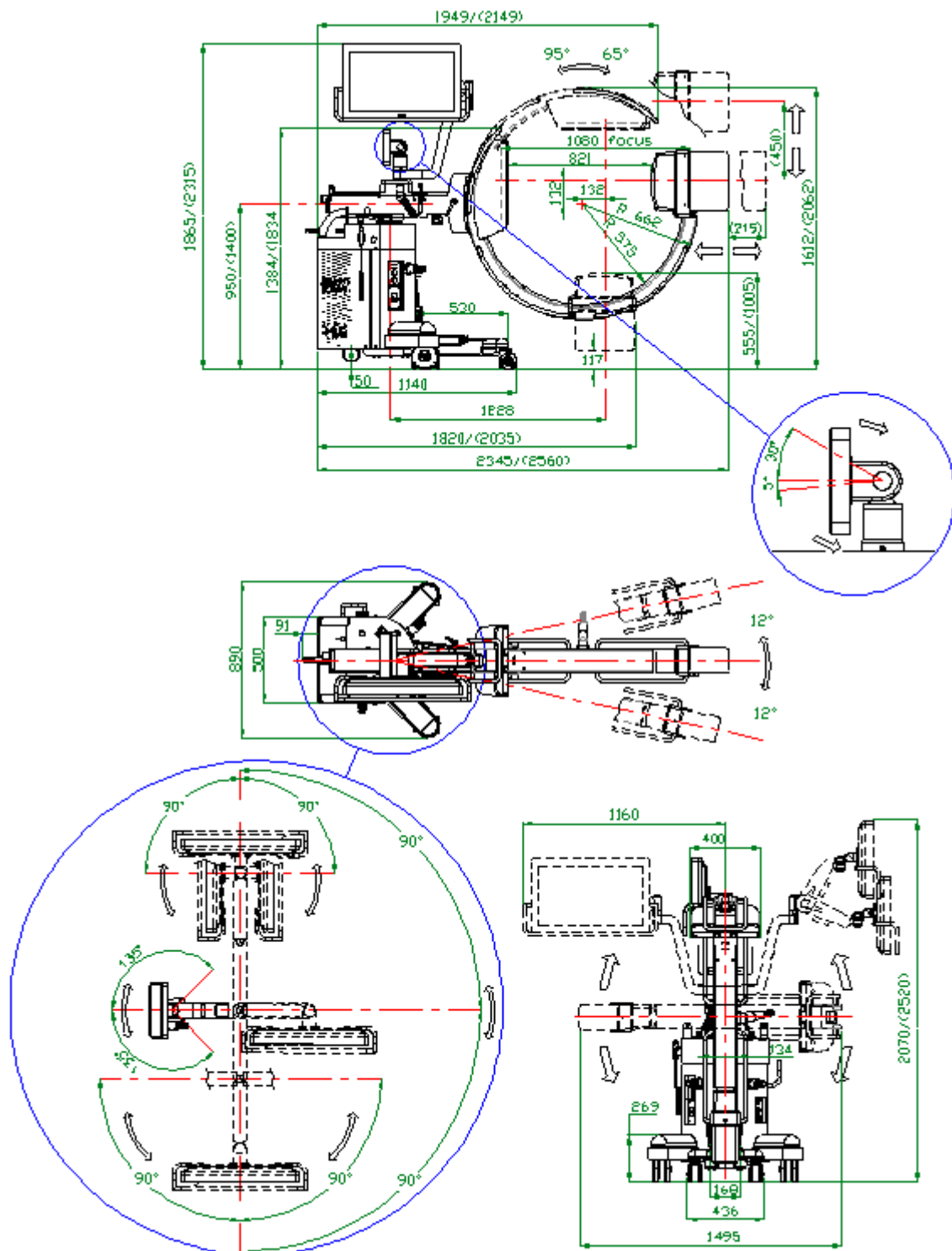

Note: Dimensions shown in mm

Weight: **310 kg**

2.5 FOCAL SPOT POSITION

Versions with **FPD 2121**

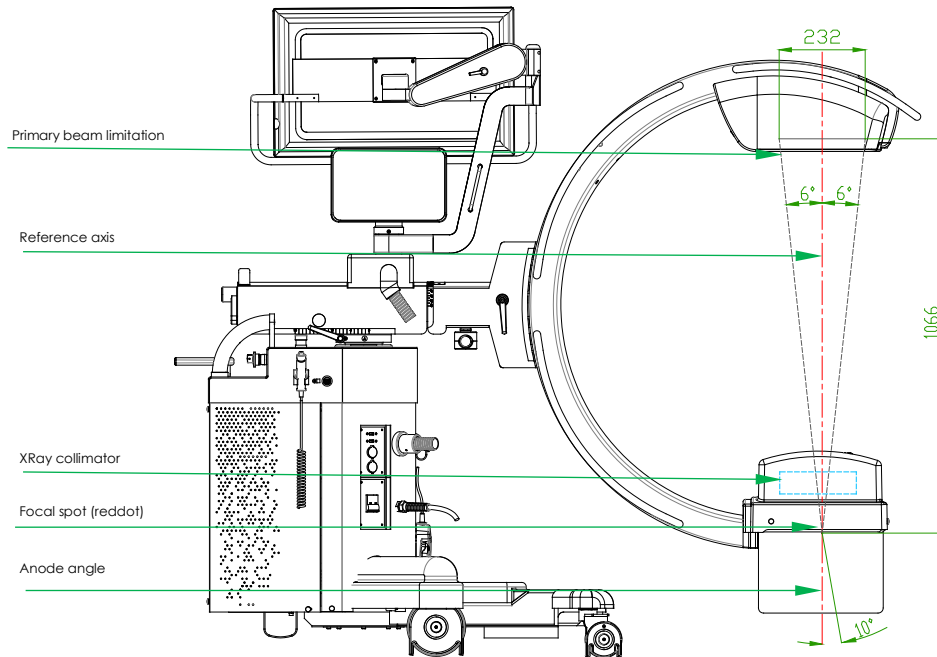

Version with **FPD 3030**

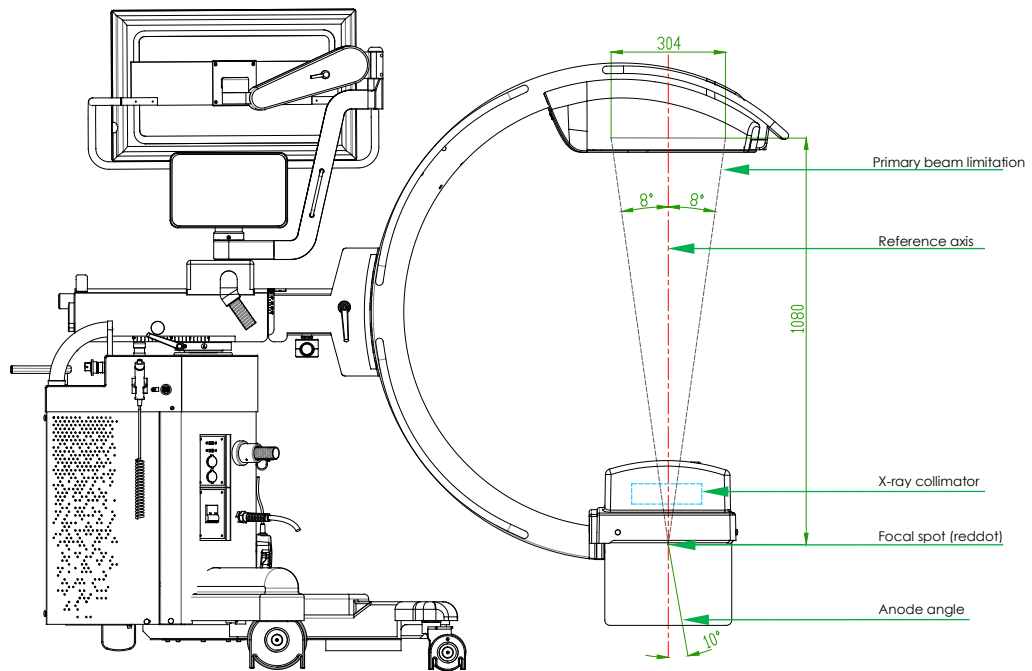

2.6 FLUOROSCOPY mA CURVES

ACQUISITION RATES: ≤ 15 FPS

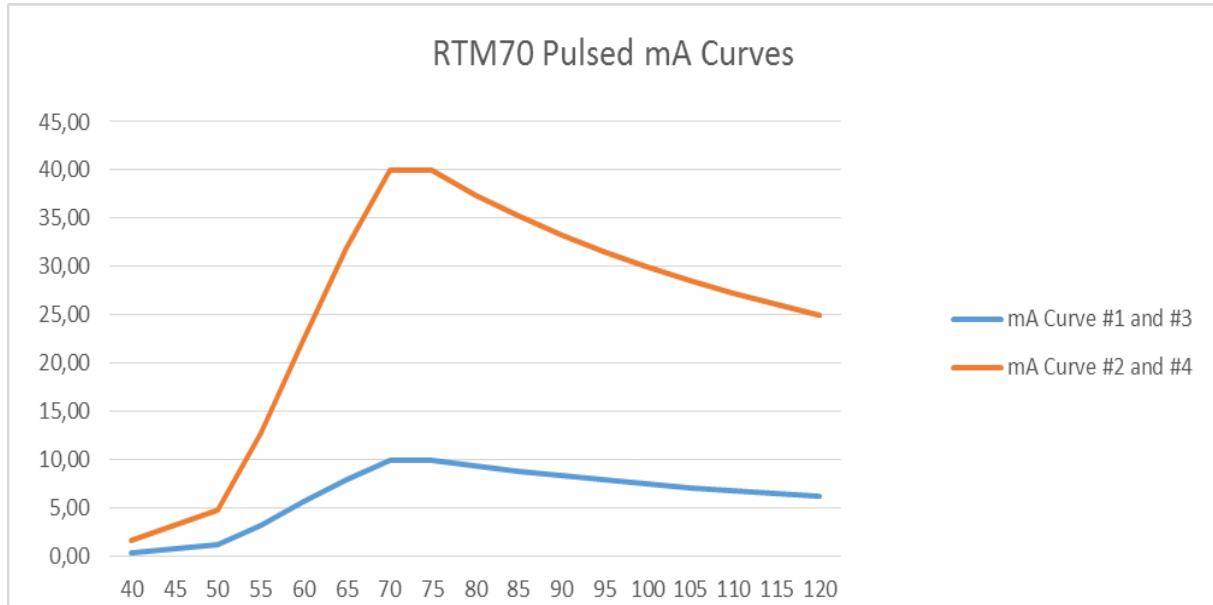

ACQUISITION RATES: 30 FPS

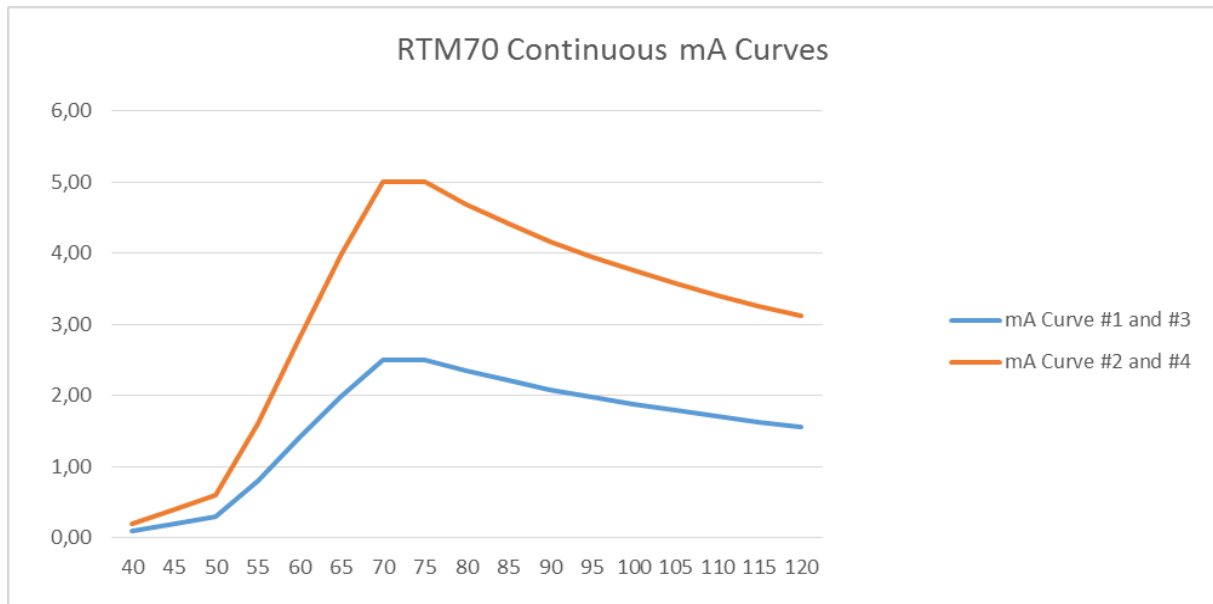

2.7 DIGITAL RADIOGRAPHY (SNAPSHOT) mA CURVES

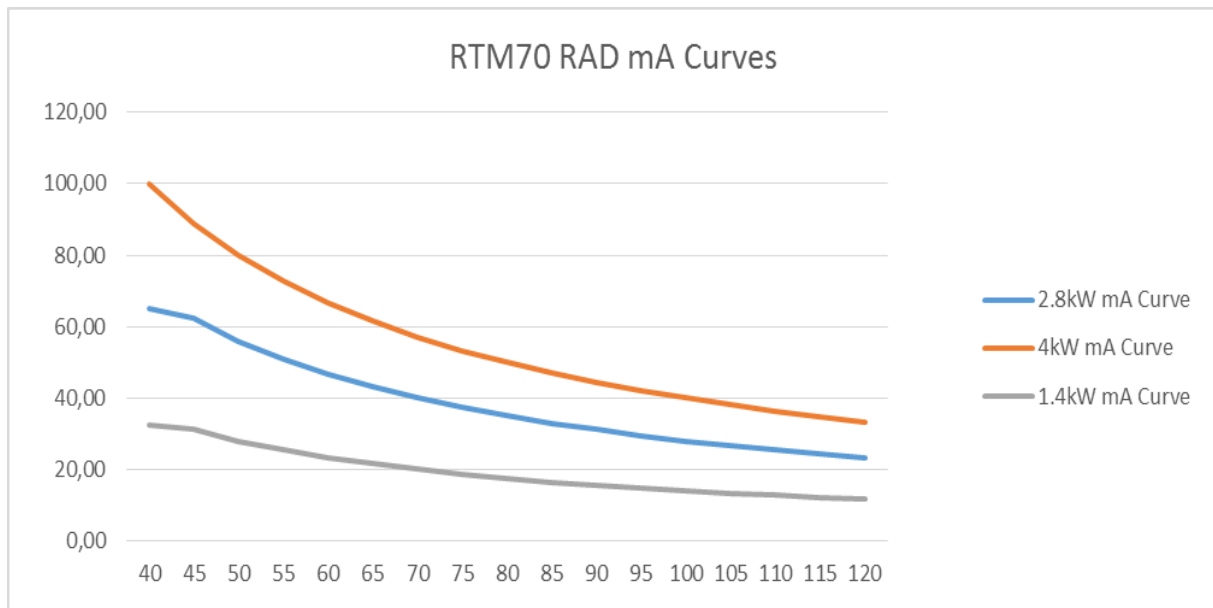

3 STORAGE AND HANDLING

3.1 PACKAGING

The EM equipment sits on a pallet and is then covered with cardboard, anchored to the pallet by straps and screws.

A ramp, needed to remove the stand from the packing, is also enclosed in the box.

Follow the unpacking instructions in reverse order should the system need to be repacked in the future (see paragraph 1.2 in Part 2 of this manual).

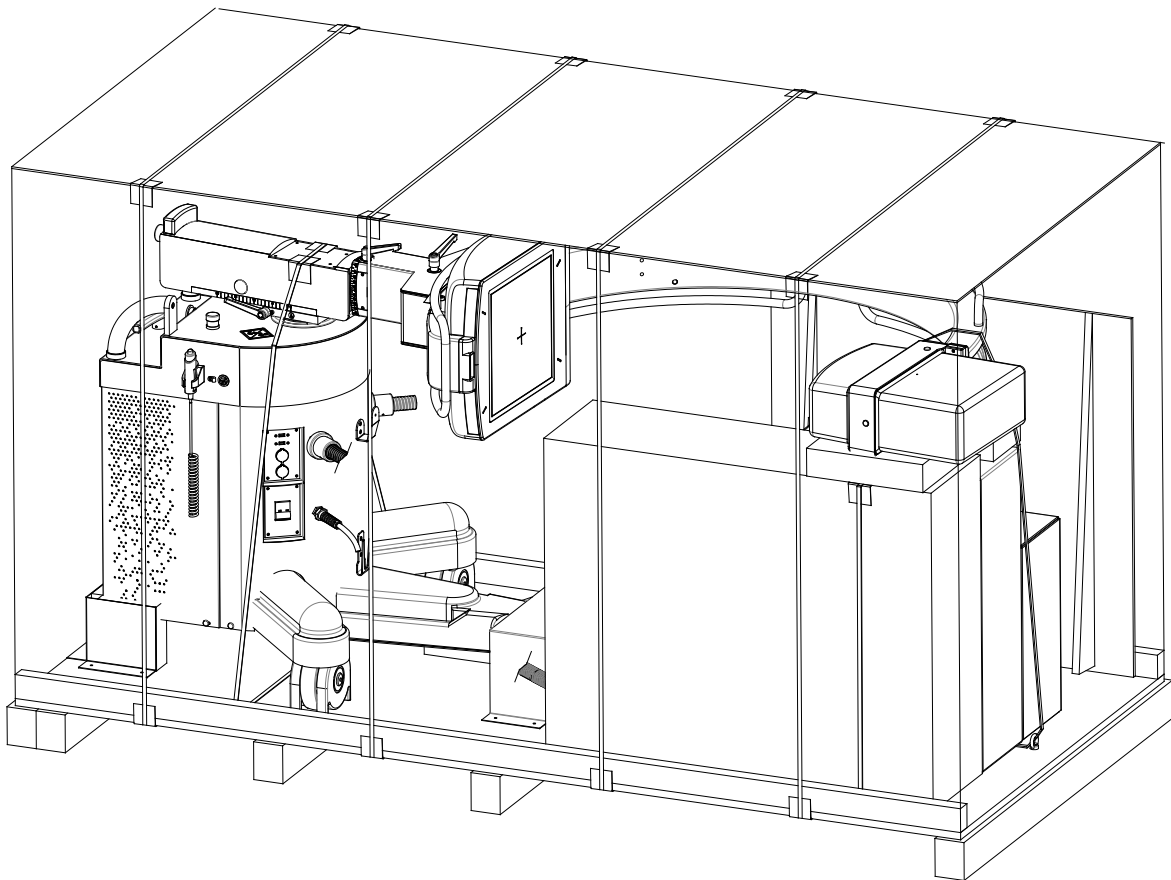

3.2 STORAGE

The environmental conditions indicated in the table below should be guaranteed for both storage and transportation:

	Max values	Recommended value
Temperature	from -10 °C to +55 °C	from +10 °C to +35 °C
Relative humidity	from 10 % to 70 %	from 20 % to 70 %
Pressure	from 70 kPa to 106 kPa	from 70 kPa to 106 kPa

Part 2: INSTALLATION

CONTENTS

	pages	rev.	Date
CONTENTS	1.1 – 1-2	A	21/03/22
1 INTRODUCTION	1.1 - 1.6	0	01/03/21
1.1 Installation procedure			
1.2 Unpacking			
1.2.1 Unpacking: cardboard packaging			
1.2.2 Unpacking: wooden packaging			
2 MECHANICAL INSTALLATION	2.1 - 2.8	0	01/03/21
2.1 Installation: cardboard packaging			
2.1.1 Monitor support arm installation			
2.1.2 Monitor installation			
2.2 Installation: wooden packaging			
2.2.1 Monitor installation			
3 ELECTRICAL CONNECTIONS	3.1 - 3.7	0	01/03/21
3.1 Connectors			
3.2 Connections			
3.2.1 Connecting the monitor			
3.2.2 Connecting the footswitch (optional)			
3.2.2.1 Connecting the wired footswitch			
3.2.2.2 Connecting the wireless footswitch			
3.2.3 Peripheral/optional connections			
3.2.4 Main power supply			
4 VIDEO PROCESSOR SETUP	4.1 - 4.58	A	21/03/22
4.1 Introduction			
4.1.1 Login			
4.2 General Settings			
4.2.1 General			
4.2.2 Auto delete			
4.3 Unit configuration			
4.3.1 Unit Configuration			
4.3.2 Sound Control			
4.4 Exam Setup			
4.4.1 Programmable parameters			
4.4.1.1 DSA Programmable parameters			
4.4.2 Image processing			
4.4.3 Exams management			
4.4.3.1 Creating a new exam			
4.4.3.2 Organize the exam list			
4.4.3.3 Duplicate an exam			
4.5 Dicom Setup			
4.5.1 DICOM Settings			
4.5.2 DICOM Services			
4.5.2.1 General			

4.5.2.2	Store			
4.5.2.3	Worklist			
4.5.2.4	Media			
4.5.2.5	Storage Commitment			
4.5.2.6	MPPS			
4.5.2.7	Radiation Dose Structured Report (RDSR)			
4.5.2.8	Query / Retrieve			
4.5.3	DICOM Devices			
4.5.3.1	Dicom TLS			
4.5.4	Spooler			
4.5.5	Print Configuration			
4.5.5.1	Print annotation setup			
4.6	DRC Group setup			
4.7	DRC Editor			
4.8	User Account Setup			
4.9	Fixed String Setup			
4.10	Security Setup			
5	ANNEXES	5.1 - 5.12	0	01/03/21
5.1	Monitor configuration			
5.1.1	Resetting the main monitor configuration			
5.1.2	Auxiliary monitor configuration			
5.1.3	Touch screen calibration			
5.2	Windows administrator log-in			
5.3	Setting up the network			
5.3.1	Physical characteristics of the Ethernet network connection			
5.3.2	Windows settings			
5.3.3	Network connections test			
5.3.4	Connection through wireless USB adapter (optional)			
5.4	Online manuals			
5.4.1	How to consult the manuals			
5.5	Software version			
5.6	Video processor back-up			
5.7	Customization of the opening screen logo			

1 INTRODUCTION

1.1 INSTALLATION PROCEDURE

The flow chart below shows the various steps in the installation procedure:

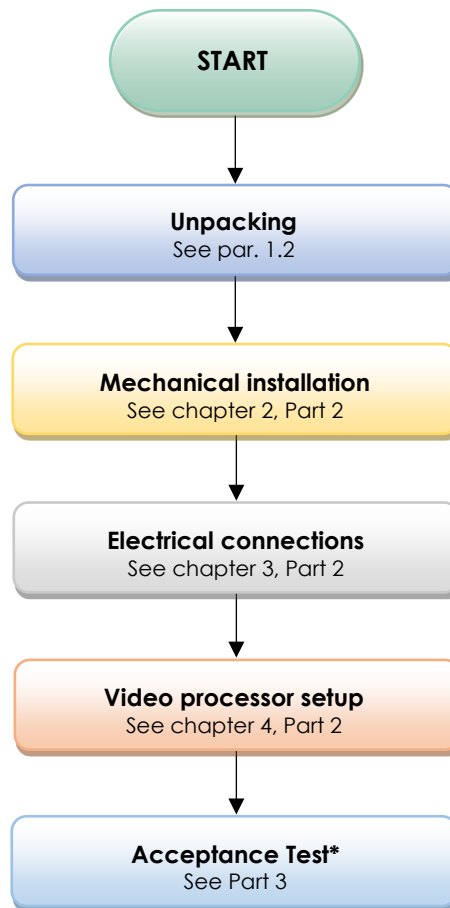

* Installation ends with an **Acceptance Test** (also valid for extraordinary maintenance) and the filling-in of the relevant "Test Sheet".

The Acceptance Test is described in Part 3 of this manual.

Each step in the installation process is described in detail in the following chapters.

Note: The EM equipment is fully adjusted in the factory to suit the user's specific requirements. Adjustments may only become necessary when components are replaced (see Part 4 of this manual).



Only qualified and suitably trained personnel should be allowed to install the EM equipment.



The EM equipment mains power supply must be consistent with that reported on its serial number plate (see Paragraph 3.2.4, Part 2 of this Manual).



The electrical circuit to which the EM equipment is to be connected must conform to IEC standard 60364:2005 section 710 (Electrical plant in medical environments) and **be properly earthed**.

1.2 UNPACKING



Only suitably trained personnel should be allowed to unpack the EM equipment.

The following paragraphs report the unpacking procedure for cardboard packaging and for wooden packaging, respectively.

1.2.1 UNPACKING: CARDBOARD PACKAGING

To unpack the equipment:

- Cut the 4 straps around the cardboard cover.

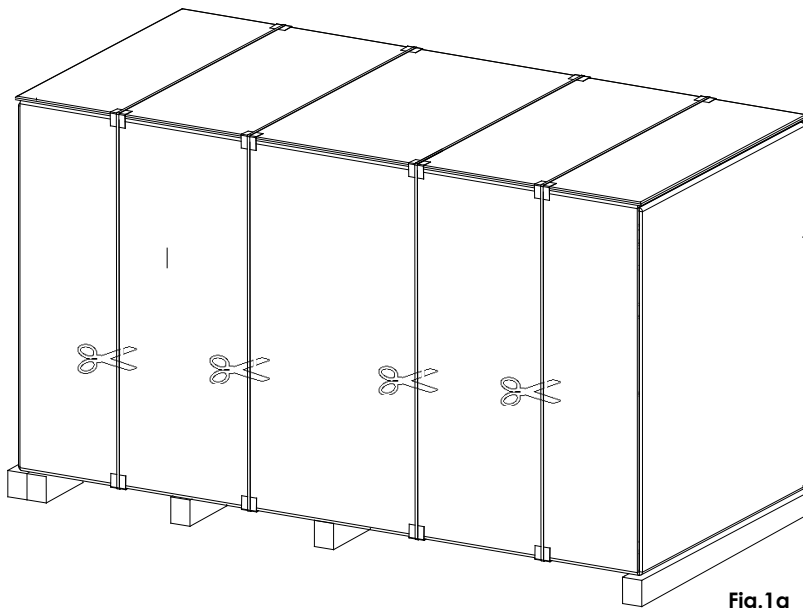

Fig.1a

- Remove the lid (A) and the screws fixing the cardboard cover (B) to the pallet (C) and then remove the cardboard by lifting this upwards.

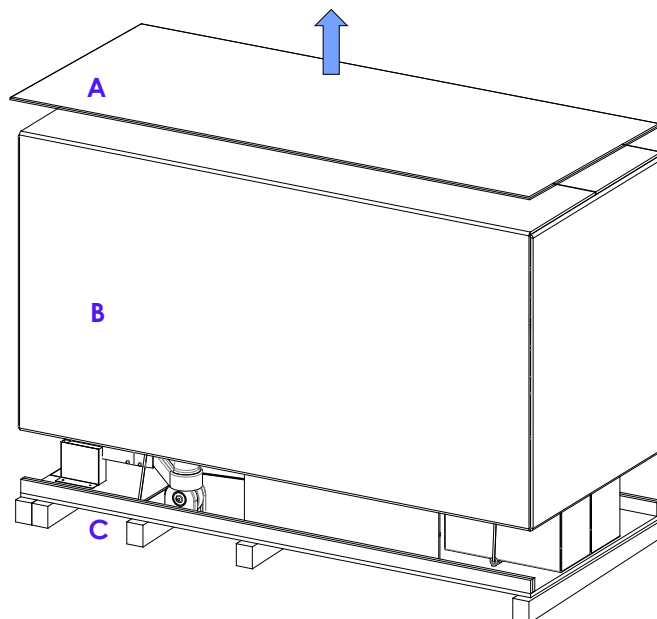

Fig.1b

- Remove the cling-film covering the material inside.
- Extract the wooden ramp (S) and place it as shown in Fig. 1f.
- Cut the internal straps securing the equipment and packing boxes for the accessories.
- Remove the boxes, accessories (B1) and monitor (B2).
- Remove the anchor supports (E1 and E2) securing the stand. To do this, undo the screws fixing them to the base of the pallet (C).

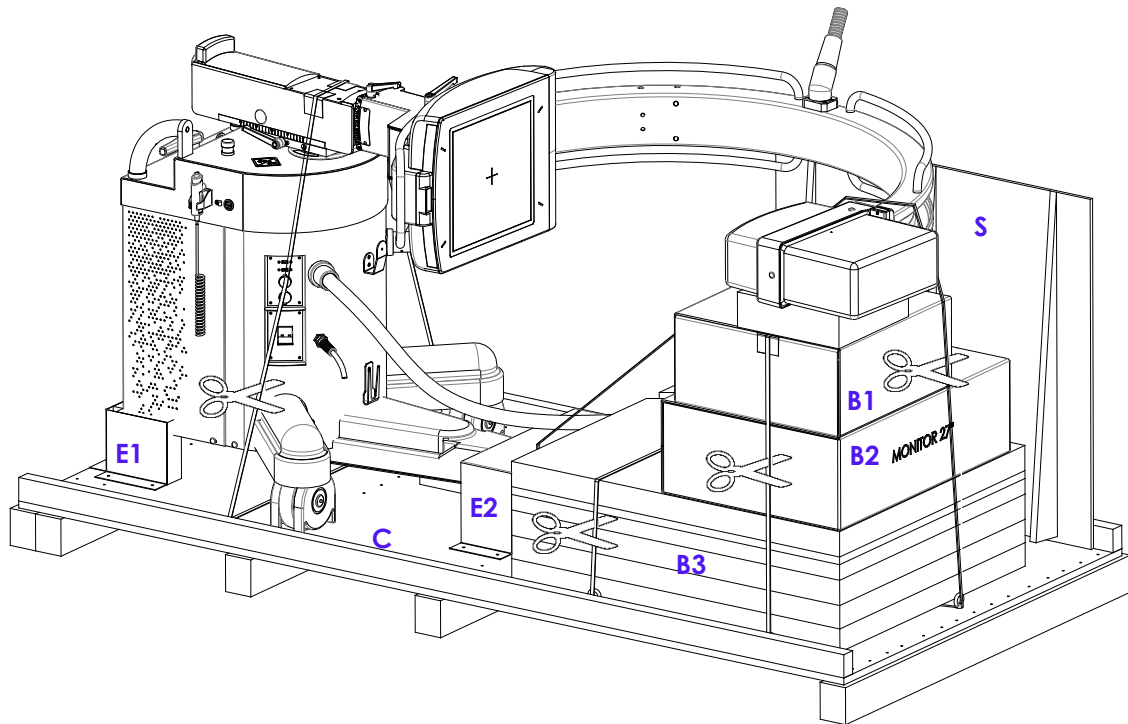

Fig.1c

- Carefully take out from the packing (B3) the monitor arm and the monitor support / handle, then install them, see para. 2.1 and 2.2 Part 2 of the present manual.

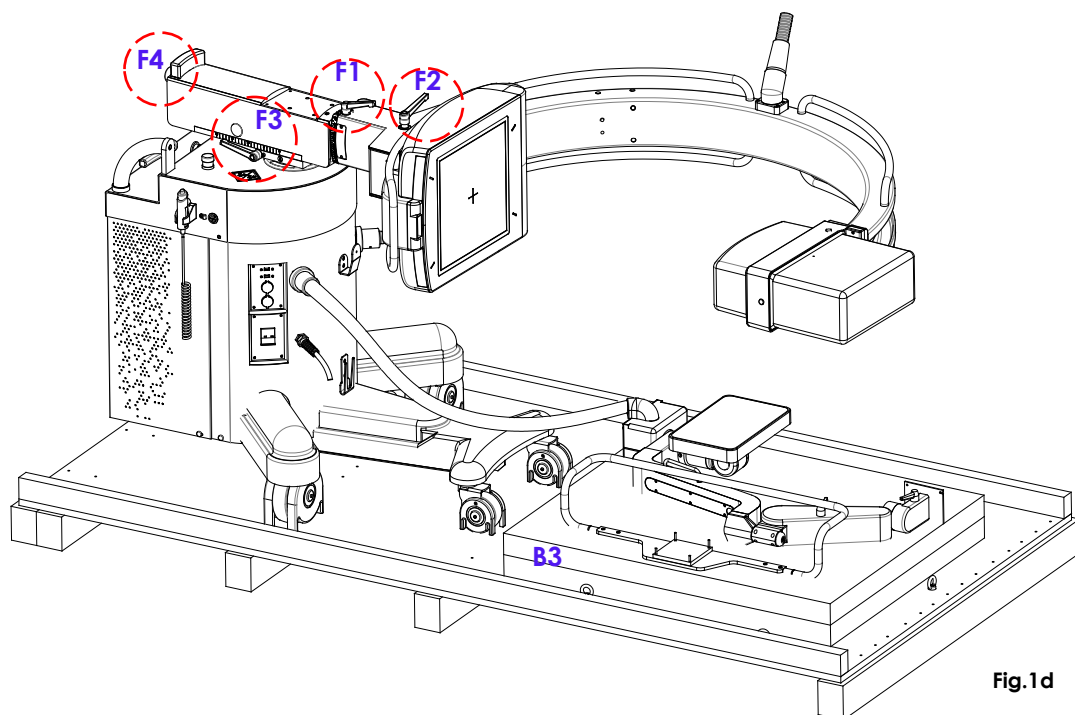
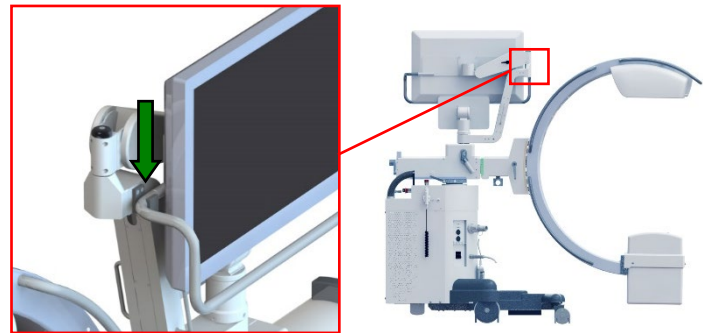

Fig.1d

- Put the equipment in transport position (Fig. 1e).
 Brake F1 to lock the C-arm rotation brake.
 Brakes F2 to unlock the C-arm sliding.
 Brake F3 to unlock the wig-wag movement.
 Brake F4 to unlock the horizontal C-arm sliding.
- Install the monitors and their stands (see Paragraph 2, Section 2 of this manual).
- Move down the equipment from the ramp (S) turning the F5 stand brake handle as visible in (Fig. 1f).



Transport position
Fig. 1e

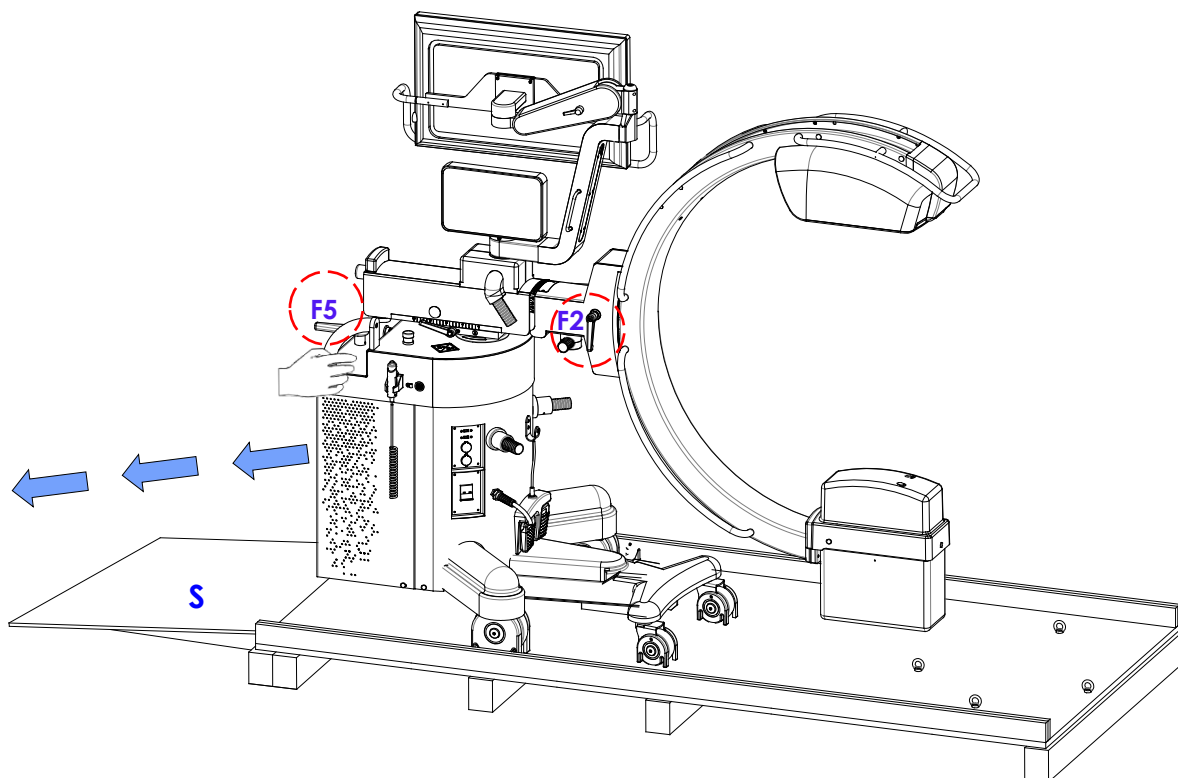
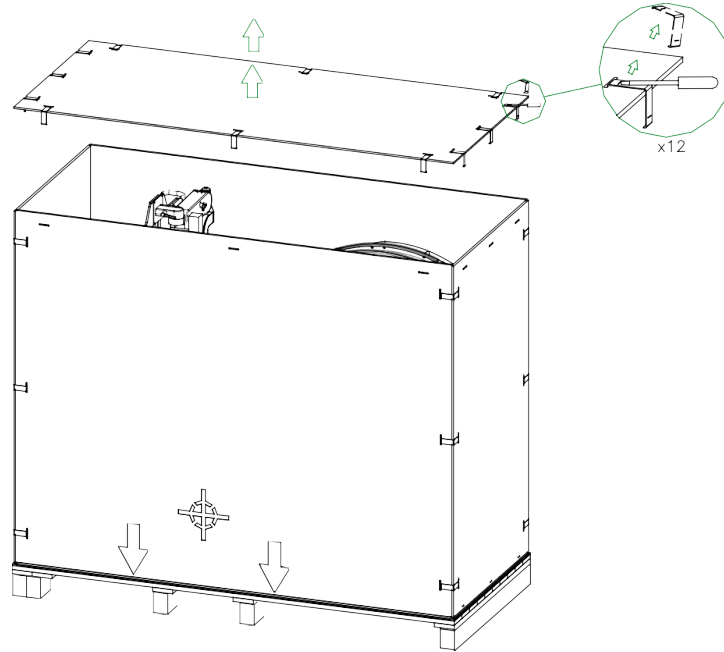

Fig.1 f

1.2.2 UNPACKING: WOODEN PACKAGING

To unpack the crate, proceed as follows:

- Using a flat-blade screwdriver or similar tool, remove the outer catches from the top cover of the crate and then remove it.



- Proceed by removing the remaining retainers so you can remove the case walls.

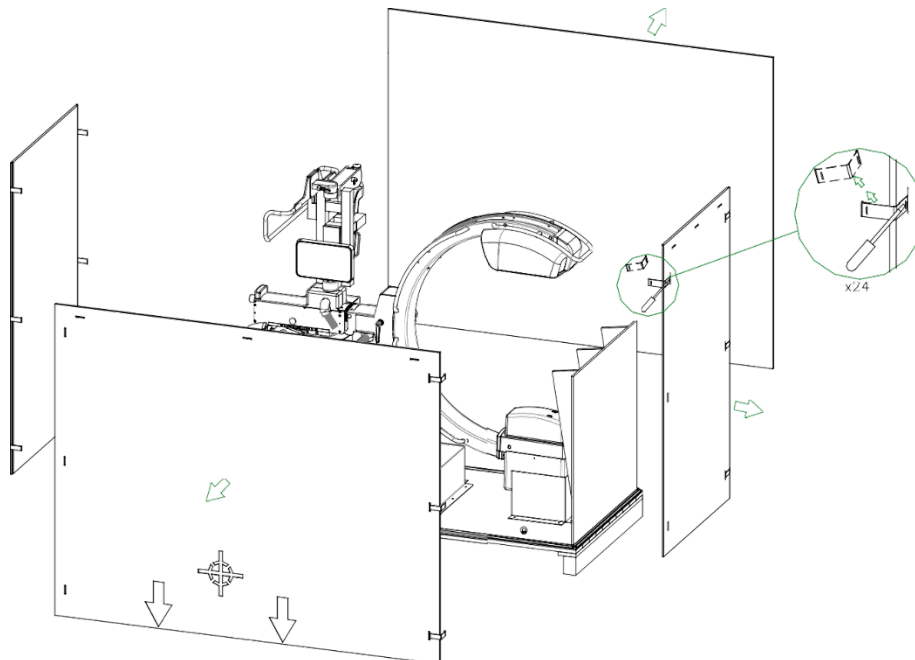

- Unlock the retaining straps and remove the protective shims, as shown. See Paragraph 2.2.2 in Part 2 of this Manual for full information on monitor installation.

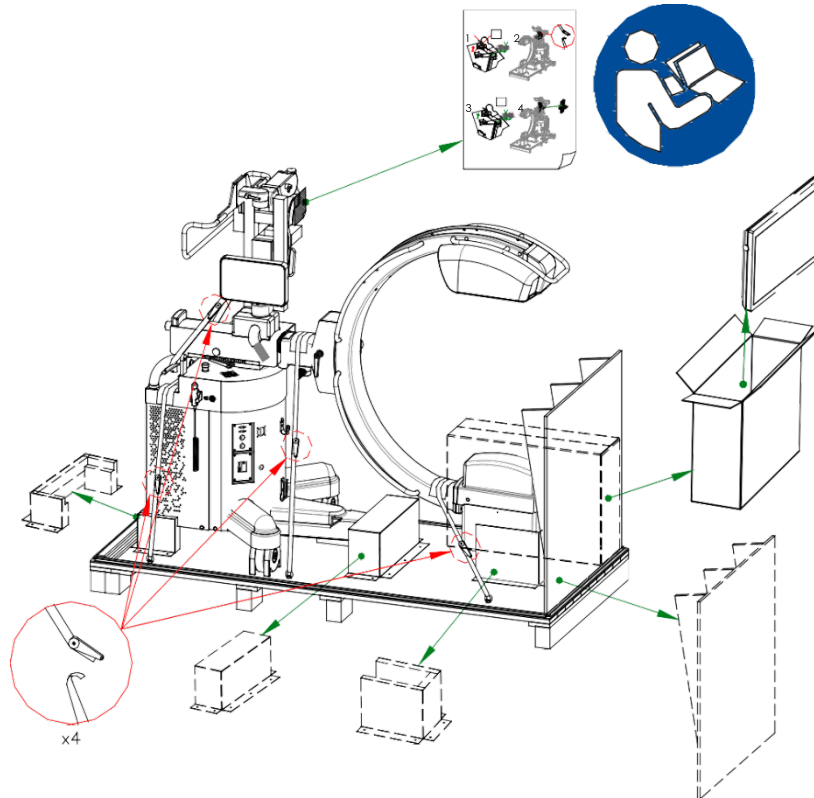

- Remove the wooden slide (S) and position it as in the figure. Release the brake lever and lower the stand.

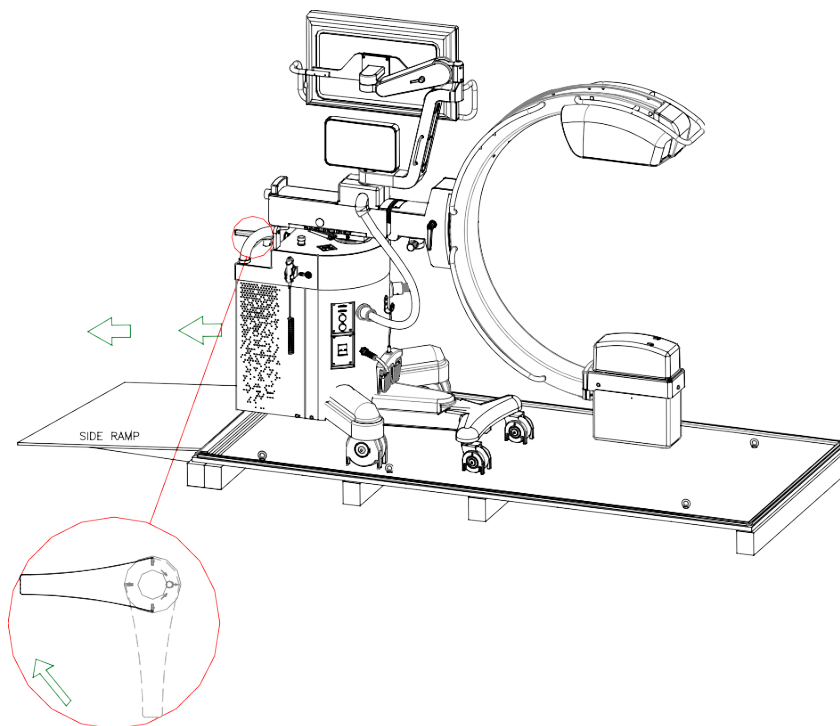

Note: If you need to repack the equipment, follow the instructions above in reverse order. Use the original protective material, clips, and straps.

2 MECHANICAL INSTALLATION

The equipment is supplied with the monitor support arm (**B**), the 27" monitor (**M**) and the monitor support/handle (**S**) which are disassembled and packed separately.

Mechanical installation involves:

- 1) Install the monitor support arm (**B**).
- 2) Install the monitor (**M**) and the monitor support/handle (**S**).

2.1 INSTALLATION: CARDBOARD PACKAGING

➤ Following steps are available for equipment delivered with cardboard crate.

2.1.1 MONITOR SUPPORT ARM INSTALLATION

 These operations require 2 persons.



- Displace the longitudinal carriage to the front: see fig.1 (for locking of the handle, see paragraph 1.3.1, Part 2 of the User Manual).
- Dismantle the plate (**P**) (which will NOT be used anymore for the assembly of the arm) removing the 4 screws (**V1**) and the 4 screws (**V2**) (which will be used for the assembly of the arm). See fig.2.

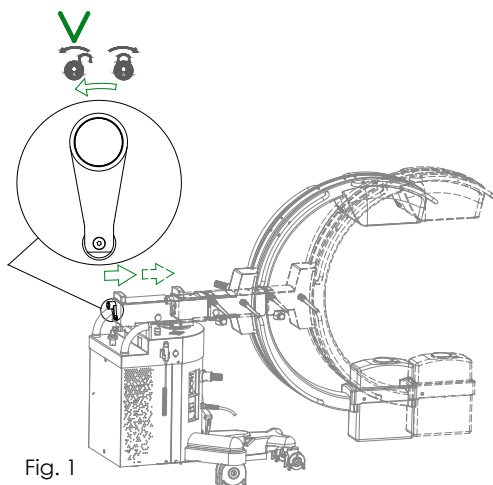

Fig. 1

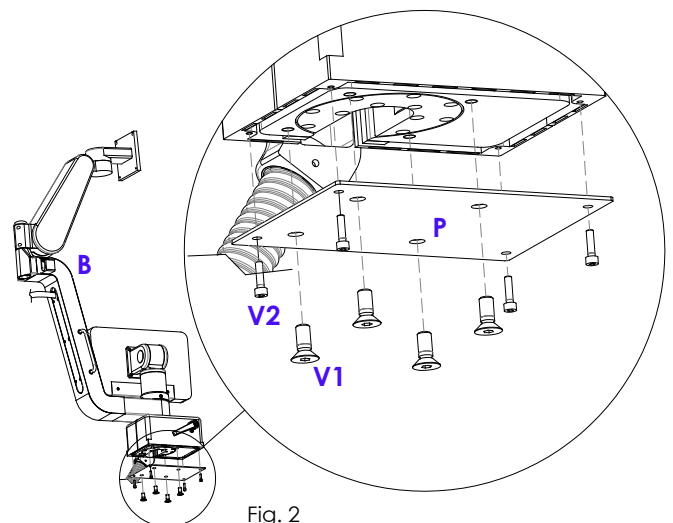

Fig. 2



Attention when unlocking the lever of the upper arm brake while the monitor is not assembled yet.

It is recommended to carry out this operation with the arm being stretched as in Fig.2.

- Assemble the monitor support arm (**B**) and fix it by tightening the 4 screws (**V1**); fix the covers with the 4 screws (**V2**). See Fig.3.

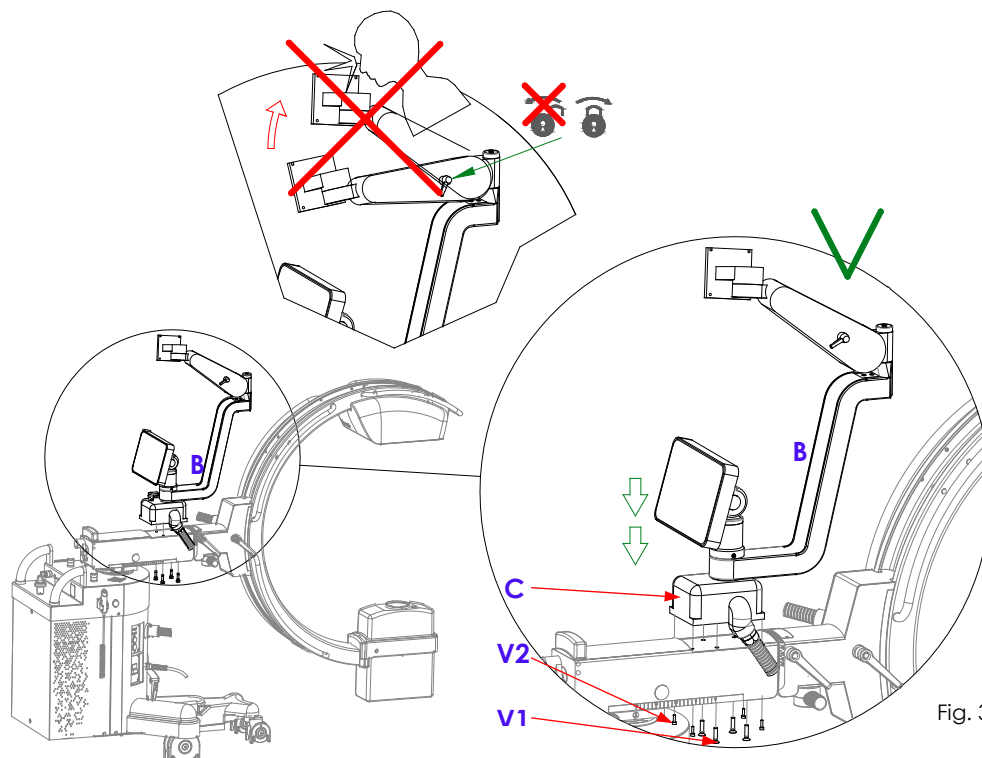

2.1.2 MONITOR INSTALLATION

The monitor is mounted in horizontal (landscape) position and with the cable entrance from below.

 These operations requires 2 persons.



- For greater comfort, lower the superior arm (**A**) manually, then lock it with the corresponding brake lever (**F**) - fig. 1.



ATTENTION when unlocking the brake lever (**F**) of the upper arm while the monitor is not mounted yet: the absence of the weight will cause the arm to rise suddenly. See fig. 2.

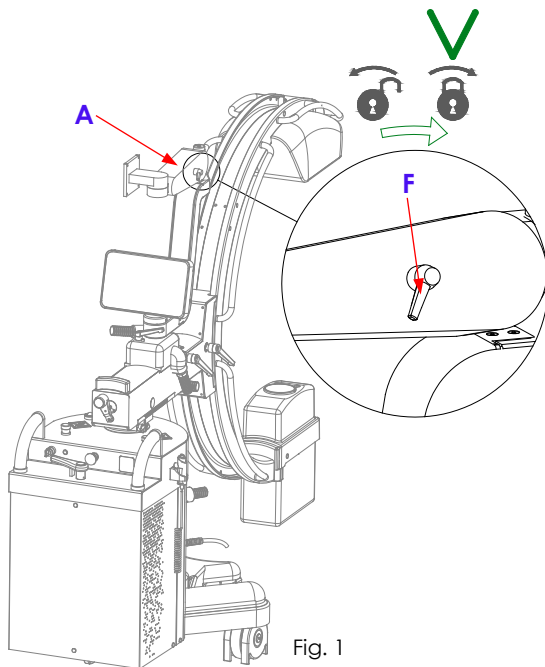

Fig. 1

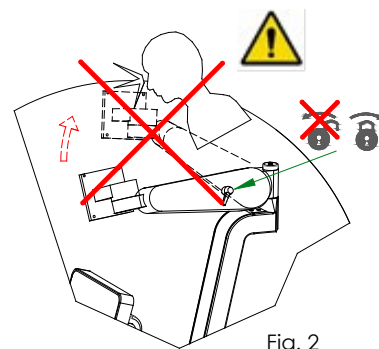
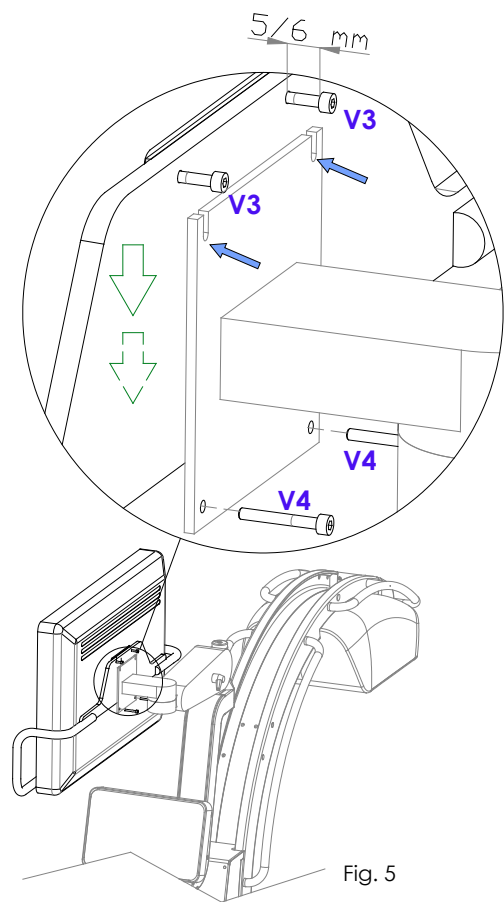
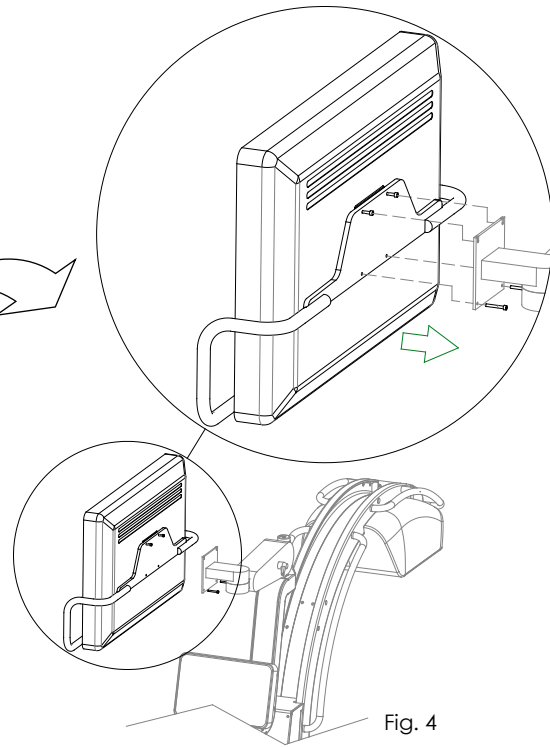
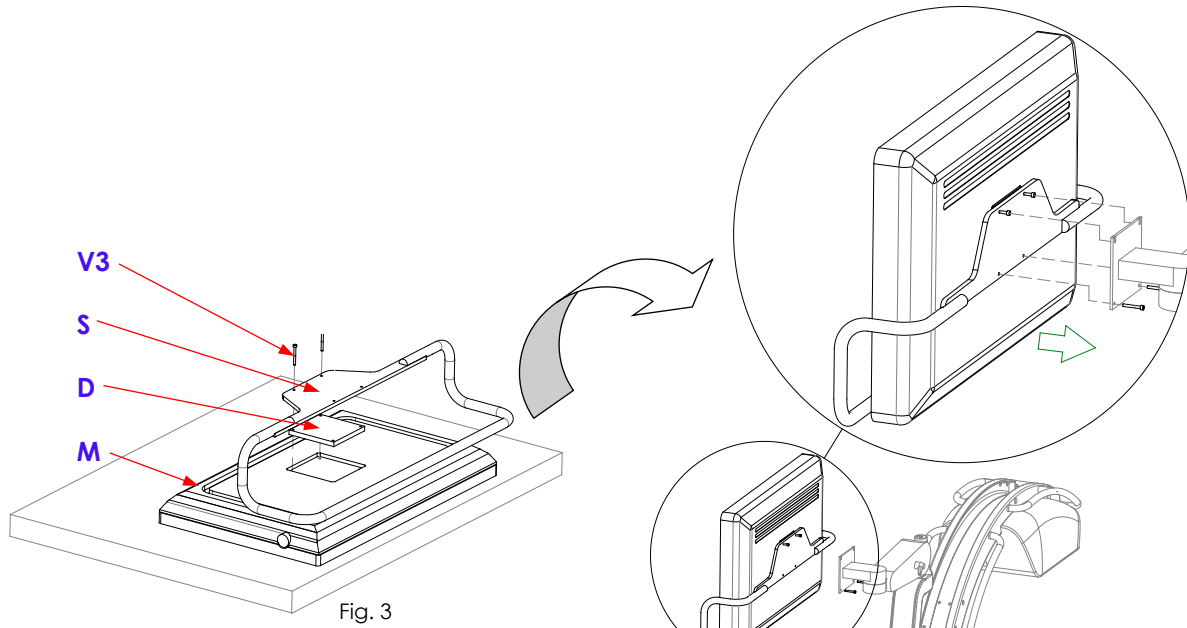
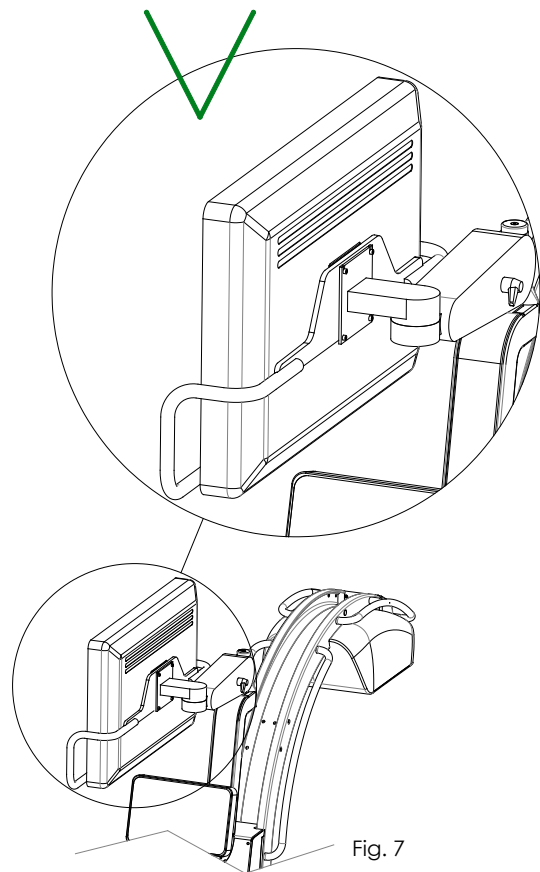
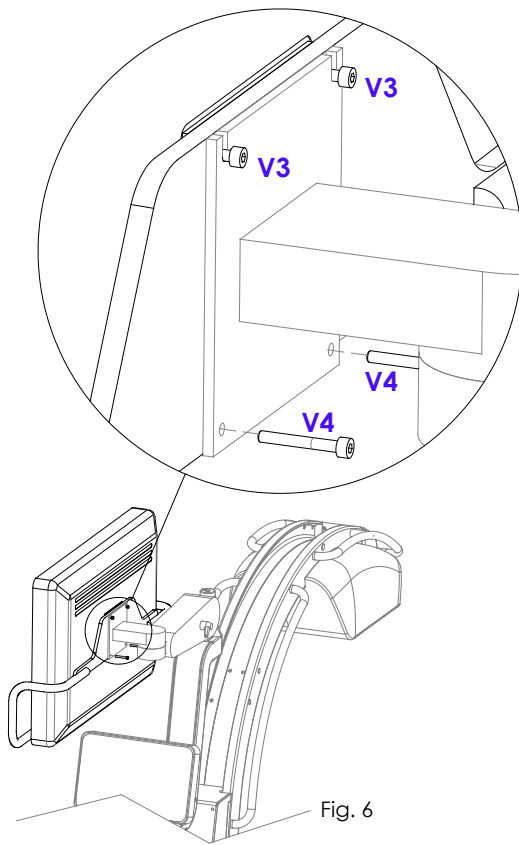

Fig. 2

- Mount the monitor support/handle (**S**) to the monitor (**M**), inserting in between the spacer (**D**) and tightening only the 2 screws (**V3**) letting them stick out temporarily some 5/6 mm – fig.3/ fig.4 /fig.5.
- Assemble the monitor group by inserting the screws (**V3**) in the cavities indicated in fig.5.
- Fasten the screws (**V3/V4**) fig.6/fig.7.
- For the electrical connections, see chapter 3 of the present Part.





2.2 INSTALLATION: WOODEN PACKAGING

➤ Following steps are available for equipment delivered with wooden crate.

2.2.1 MONITOR INSTALLATION

1 Make sure that the brake lever of the upper arm is locked.



ATTENTION when unlocking the brake lever of the upper arm while the monitor is not mounted yet: the absence of the weight will cause the arm to rise suddenly (see fig. 1a).

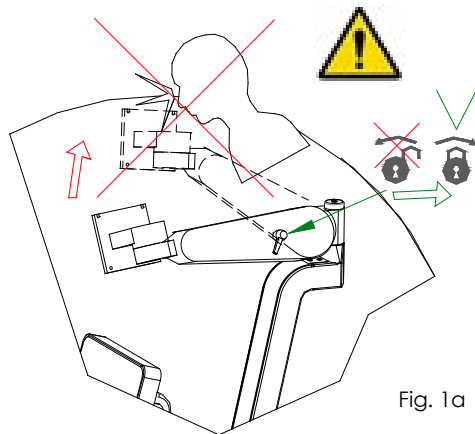

Fig. 1a

2 Unlock the retaining strap (Fig. 2a) and **carefully** unlock the brake lever of the upper arm.



ATTENTION when unlocking the brake lever of the upper arm while the monitor is not mounted yet: the absence of the weight will cause the arm to rise suddenly (fig 3a).

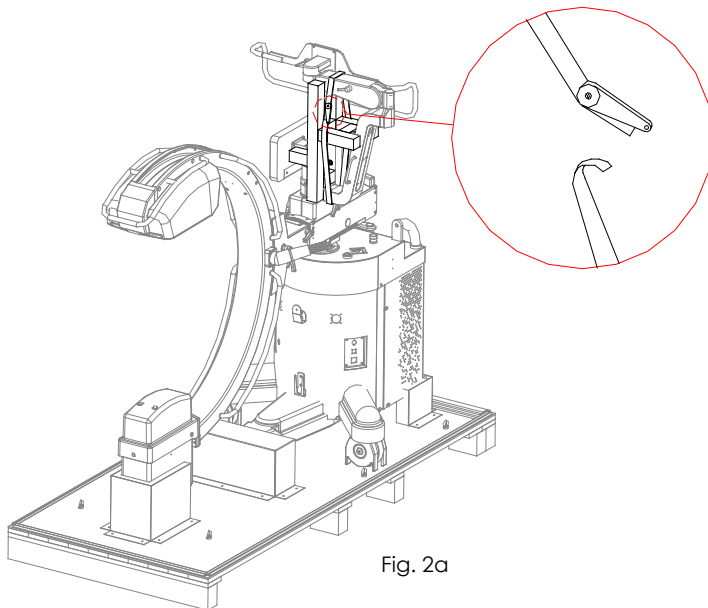

Fig. 2a

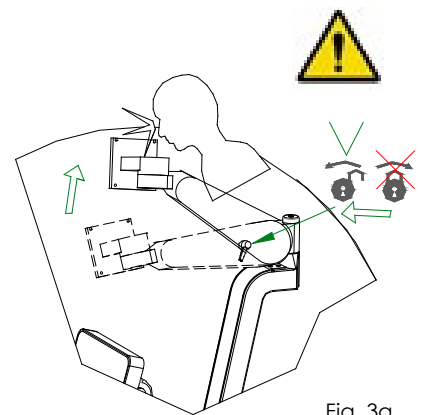

Fig. 3a

- 3 With the brake lever unlocked, it is possible to pull out the wooden support (fig. 4a).
Now, lower the arm and lock the brake lever again (fig. 5a).

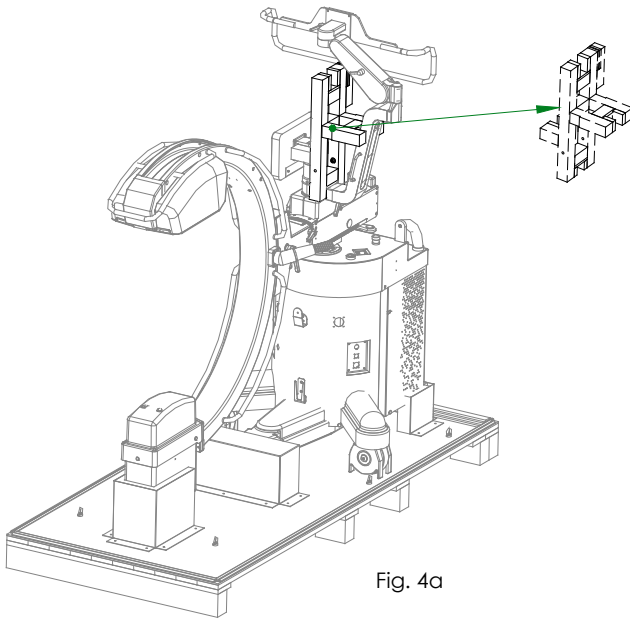

Fig. 4a

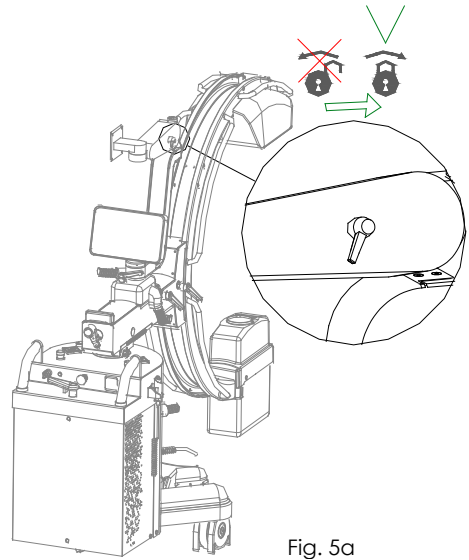

Fig. 5a

- 4 Unscrew the nuts, as shown in fig. 6a.

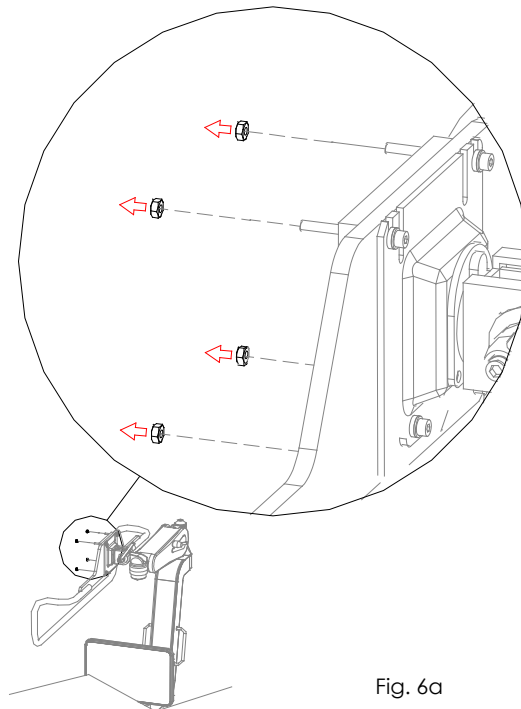

Fig. 6a



- 5 Bring the monitor closer to the mounting plate, aligning it with the 4 anchoring screws (fig. 7a). Tighten the 4 anchoring screws (fig. 8a).

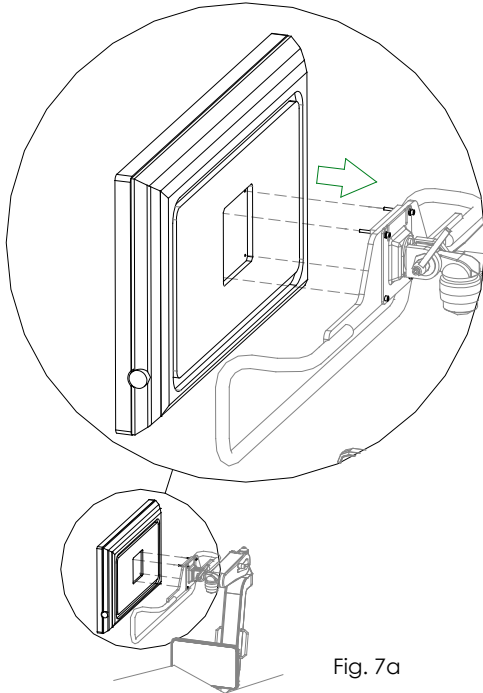

Fig. 7a

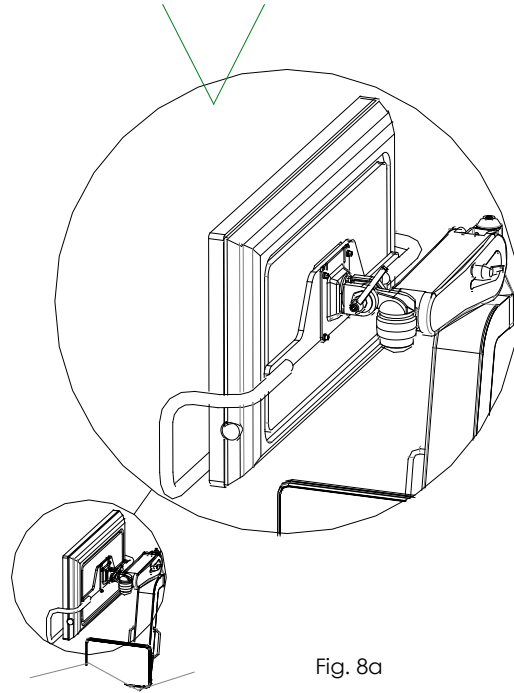

Fig. 8a

3 ELECTRICAL CONNECTIONS

3.1 CONNECTORS

Module / Figure	Connector	Connected to:
Stand Fig. 1a, 1b)	CB1	X-ray pushbutton
	CB2	Equipotential earth connector (X-ray theatre)
	CB3	Footswitch
	CB4	Injector connection
	CB5, CB6	USB ports
	CB7	Ethernet (DICOM)
	CB8	HDMI Port for auxiliary monitor
	Monitor Fig. 2)	EARTH
USB T.S.		USB cable (touch screen)
DISPLAYPORT		DISPLAYPORT video cable
POWER SUPPLY		Power supply (24 VDC)
Video processor ARCO FP-S/VP Fig. 3)	POWER SUPPLY MAINS	Mains supply (230VAC)
	USB port	Monitor Touch screen
	USB port	HUB USB: 2 USB connectors (CB5, CB6) + NFC Reader (optional)
	LAN 1	CB7 (DICOM Network)
	LAN 2	Board CTBK-HW
	LAN 3	FPD
	DisplayPort	Monitor
	DVI out	Auxiliary monitor

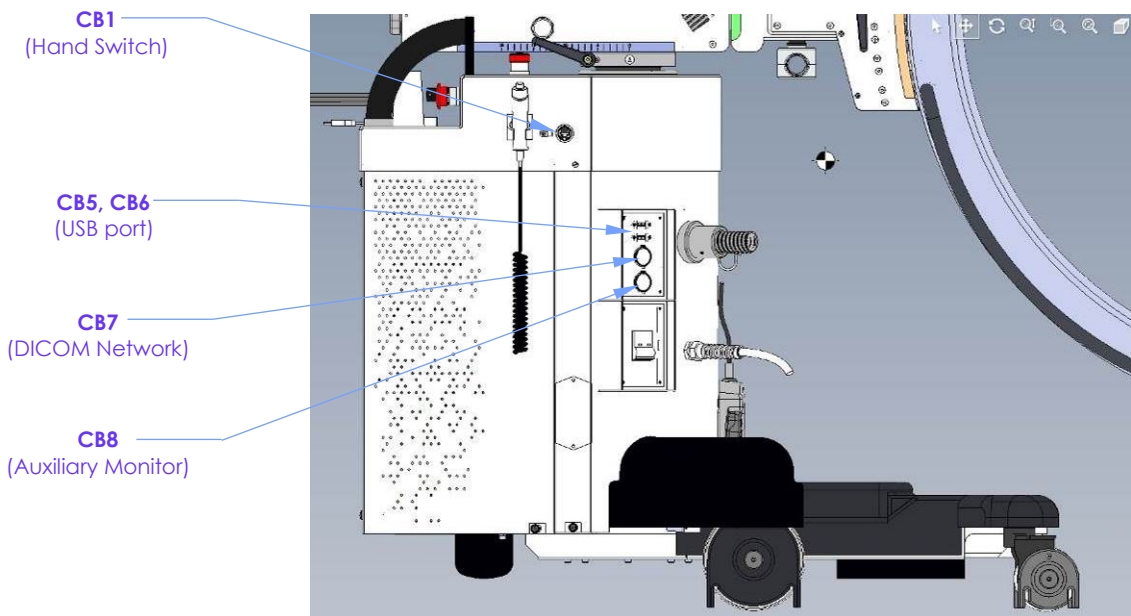

Fig. 1a

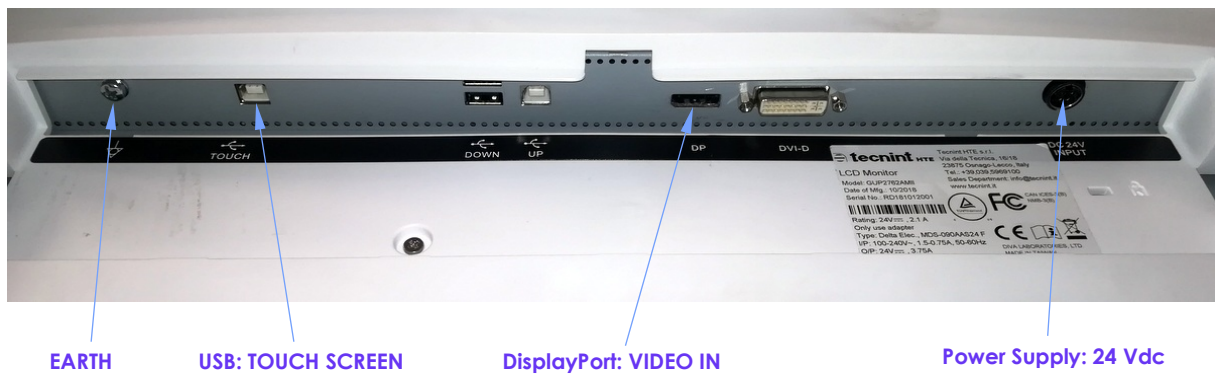
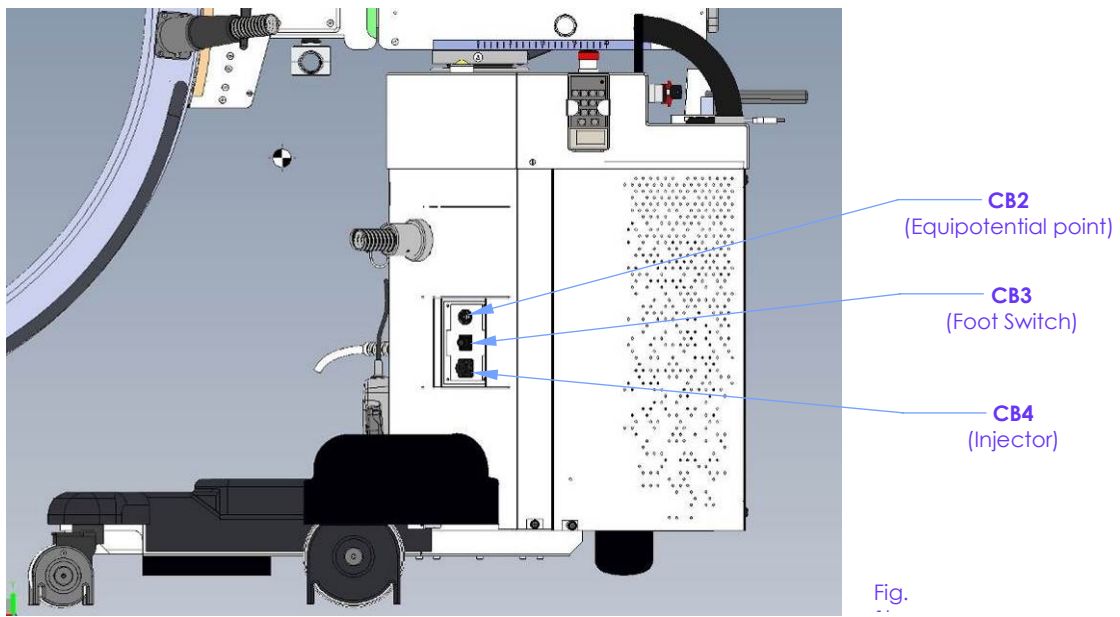

Fig. 2
(Monitor 27")

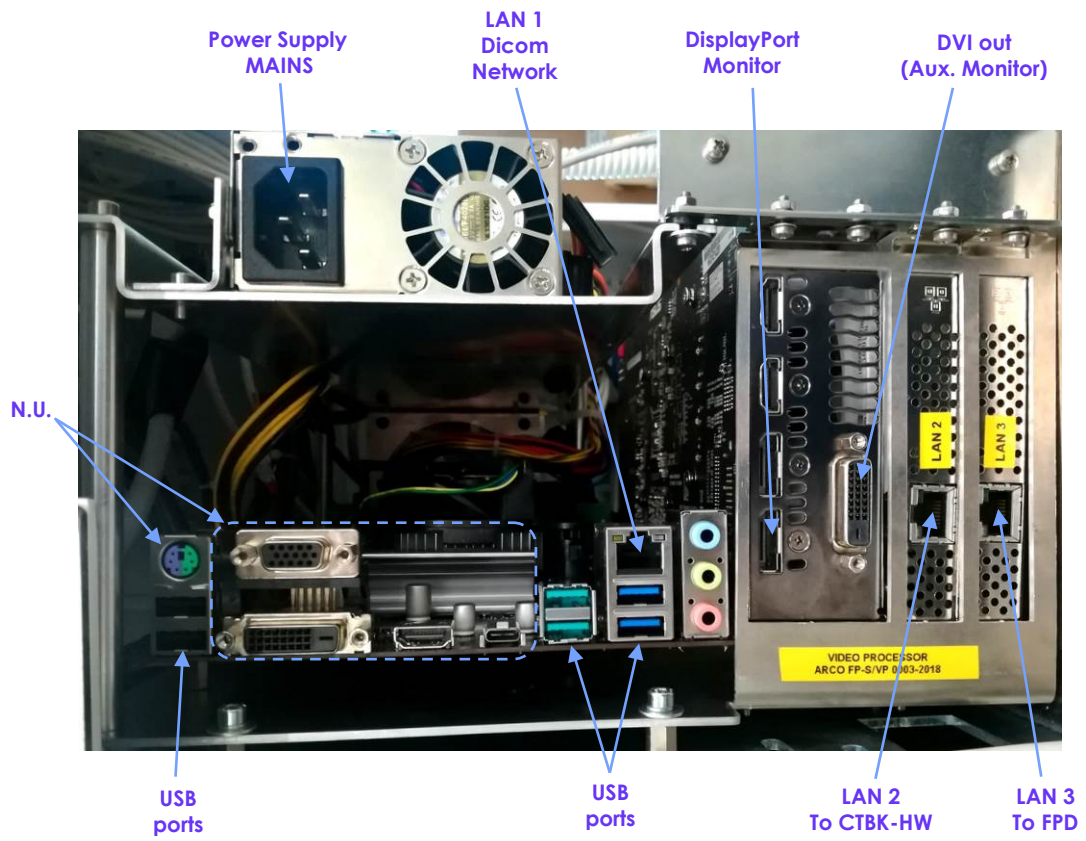

Fig. 3
(Video Processor)

3.2 CONNECTIONS

The connections required during installation are described in the paragraphs below.

Note 1: See the block diagram in Figure 17 below for the default connections. 6.

3.2.1 CONNECTING THE MONITOR

- Referring to Fig. 2, connect to the monitor:
 - The earth cable to the EARTH terminal,
 - The power cable to the DC 24V INPUT,
 - The DisplayPort video cable,
 - The USB Touch Screen cable,

3.2.2 CONNECTING THE FOOTSWITCH (OPTIONAL)

3.2.2.1 CONNECTING THE WIRED FOOTSWITCH

- Connect the footswitch cable to connector **CB3** on the stand (see previous Fig. 1b).

3.2.2.2 CONNECTING THE WIRELESS FOOTSWITCH

In order to carry out the **pairing procedure** between wireless footswitch and receiver, placed on the monitor unit left side, follow the instruction below:

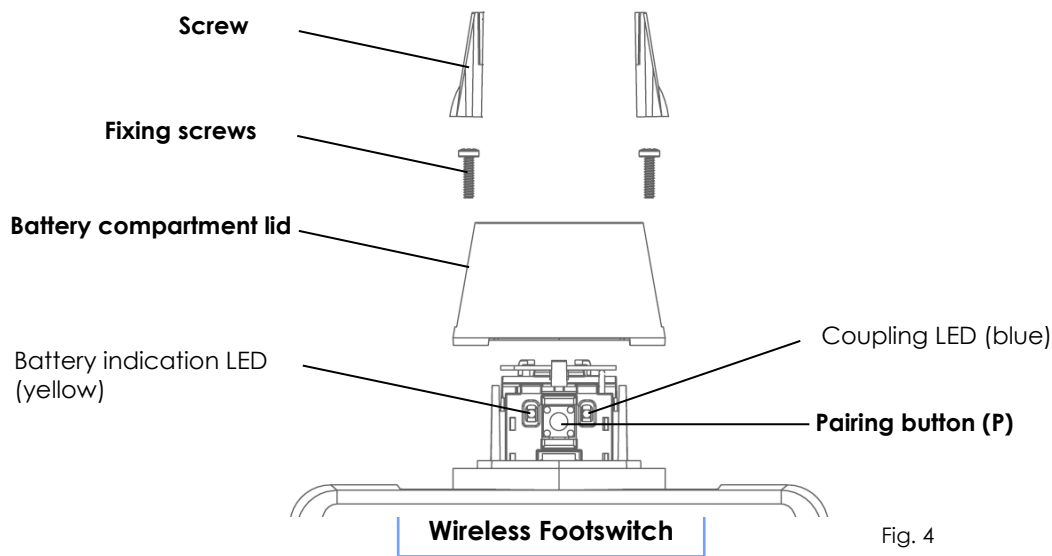



Fig. 4

- Remove the screw covers using a small flat bladed screw driver or similar.
- Undo the screws and remove the battery compartment lid.
- Press and release the **footswitch pairing button P** (see fig. 4): the blue **pairing LED** starts flashing.
- Press and release the **receiver pairing button R** (see fig. 5): the blue **pairing LED** starts flashing.

Receiver Front Panel:

-  **Pairing button (R)**
- 1. **Connection with transmitter 1 LED**
- 2. **Connection with transmitter 2 LED**
-  **Footswitch battery level indication LED**
- A. **Pairing indication LED**
- B. **Output activated LED**
- C. **Led Power On**

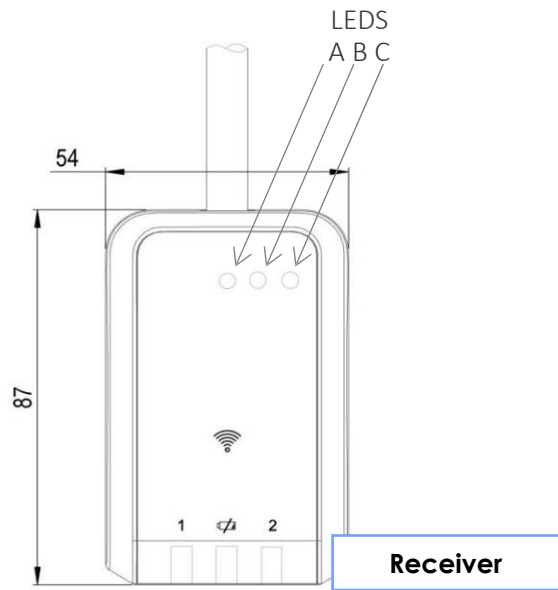

Fig. 5

- **Led 1** on the receiver starts flashing. It means the receiver has been reached and it is scanning for an advertising transmitter.
- Once they have discovered each other, the **Footswitch pairing LED** and the **Receiver pairing LED A** will switch on for 5 seconds.
- Press and release the Footswitch pairing button a second time to confirm pairing. Both LEDs will stay on for a few seconds, then flash three times to indicate the pairing procedure has been successfully carried out.

If a wireless footswitch needs to be replaced, it is required to unpair the old one, first. This can be done in one of two ways

1. If the old footswitch is still on and working, it is enough to press and hold the **receiver pairing button (P)** for at least 5 seconds (see Fig. 4); The **connection LED 1** of the receiver turns off meaning that the process has been successful.
2. If the old footswitch is not working or disconnected, press and hold the **footswitch pairing button (R)** on the receiver for at least 5 seconds (see Fig. 5); The **connection LED 1** of the receiver turns off meaning that the process has been successful.

3.2.3 PERIPHERAL/OPTIONAL CONNECTIONS

- Connect the Ethernet cable for the DICOM network to connector **CB7** on the stand (See previous Fig. 1a)
- Connect the pen drive to one of the USB connectors: **CB5** or **CB6** of the stand (See previous Fig. 1a)
- Connect the injector cable to connector **CB4** on the stand (see previous Fig. 1b)

Note: See paragraph 6.2 in the Annex to Part 5 of this manual for details of the injector cable.

3.2.4 MAINS POWER SUPPLY

The EM equipment is provided already prepared to work with **230 VAC** or **120 VAC**, depending on customer requirements.

Mains power supply is reported on the serial number plate, on the monitor unit.

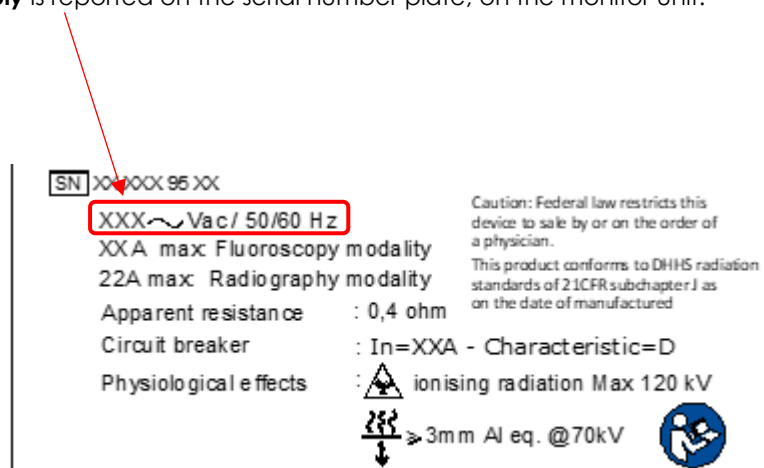

The EM equipment must be connected to a properly-earthed mains, with a correct supply tension.

The maximum absorbed current is approximately:

- 10 A in fluoroscopy (230 VAC)
- 16 A in fluoroscopy (120 VAC)
- 22 A in radiography.

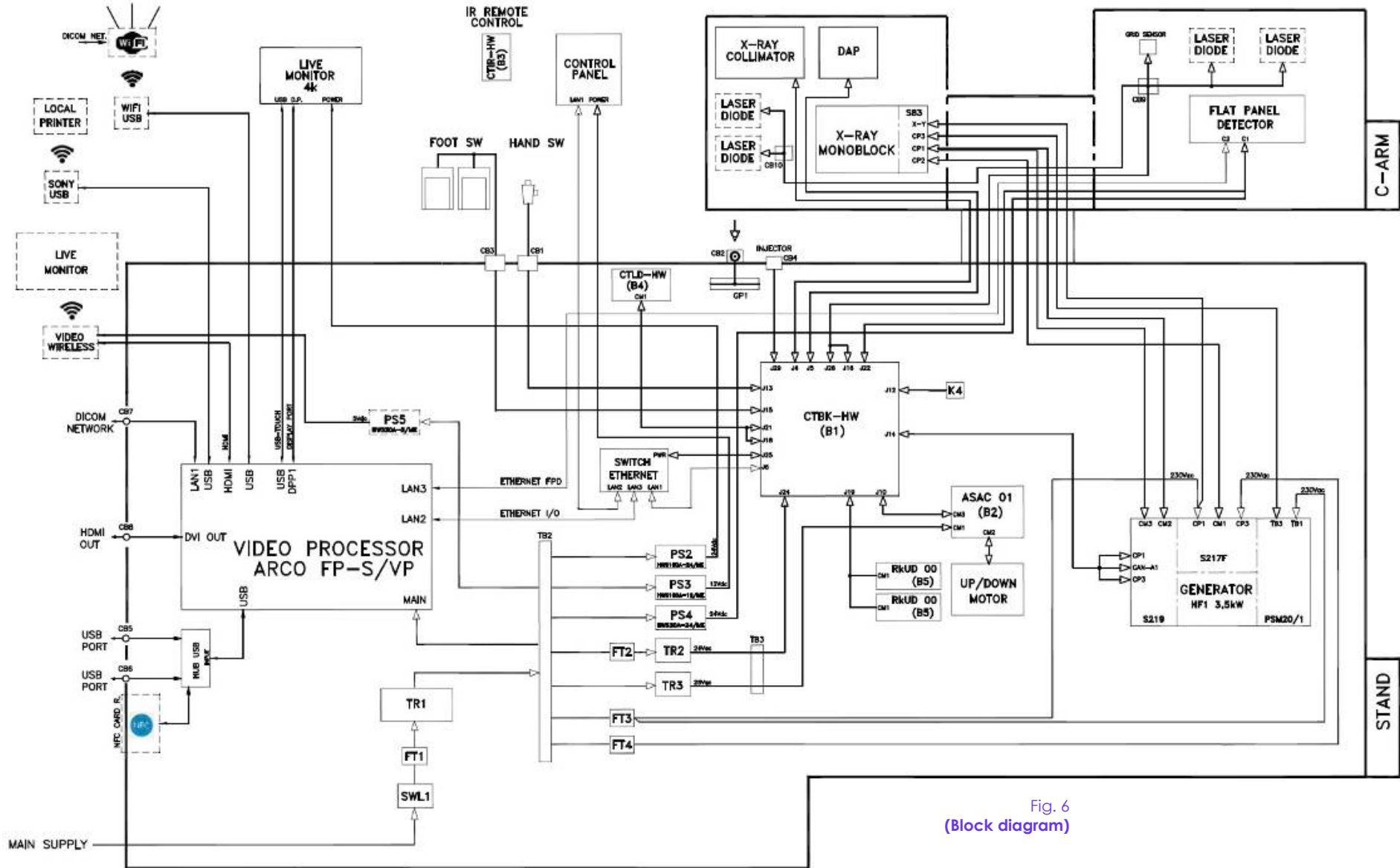

Fig. 6
(Block diagram)

4 **VIDEO PROCESSOR SETUP**

4.1 INTRODUCTION

The general configuration of the EM equipment is made on the monitor touchscreen using the specific setup pages.

The setup procedure is described below, with details of the parameters that can be adjusted to suit the specific installation needs.

Setup	Settings	User	Ref. (paragraphs)
General Settings	General - Station Description - Technical Configuration - Autoshutter Configuration - Snapshot specific configuration - Detector Sensitivity - Image Option and Unit of measure	Administrator Advanced	Para. 4.2.1
	Auto Delete - Auto Delete study - Auto Delete processing - Auto Delete study thresholds	Administrator Advanced	Para. 4.2.2
Unit configuration	- CTBK connection parameters - CI connection parameters - Unit Configuration - Rx sound control	Administrator Advanced	Para. 4.3
Exam Setup	- Exam acquisition parameters and image processing	Administrator Advanced	Para. 4.4
Dicom Setup	- Dicom Setting - Dicom Services (Store, Worklist, Media, Storage commitment, MPPS, Dose SR, Query / Retrieve) - Dicom Devices - Spooler - Print Config	Administrator	Para. 4.5
DRC Group Setup	Composition and organization of the DRC Group	Administrator	Para. 4.6
DRC Editor	Change the process names to make them clearer for the operator.	Administrator	Para. 4.7
User Account Setup	Composition and organization of Users	Administrator Advanced	Para. 4.8
Fixed String Setup	Composition and organization of the fixed strings	Administrator Advanced	Para. 4.9
Security setup	Security features	Administrator	Para. 4.10
Detector Calibration	Calibration of the detector	Administrator	Part 4 Chapter 3 3
Collimator Calibration	Calibration of the X-ray collimator	Administrator	Part 4 Para. 2.2
Generator Calibration	Calibration of the X-ray generator	Administrator	Part 4 Para. 2.1
Software Version	List of the software versions used	Administrator	Para. 5.6

Note:

- The setup menu **highlighted in blue** are also available for the Advanced user (some of the parameters should not be changeable by this user). In order to grant the full access to Video Processor setup functions, it is required to enter as ADMINISTRATOR in the Login frame of the **Systema DRF-S** application.
- See paragraph 4.1.1. below for details on the Log-in procedure.

Click the USER icon in the top left-hand corner of the Memory Monitor to open the menu that lets you access the system SETUP to suit the user profile selected during LOGIN.

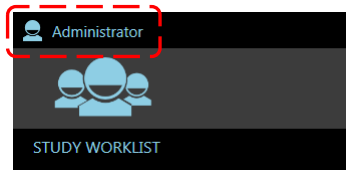

Select the **Setup** option to access the SETUP menu:

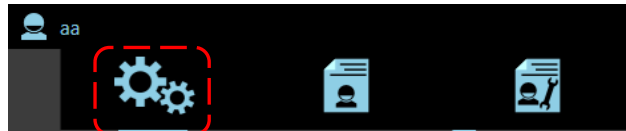

List of SETUP menus:

- accessed after logging in as ADMINISTRATOR:

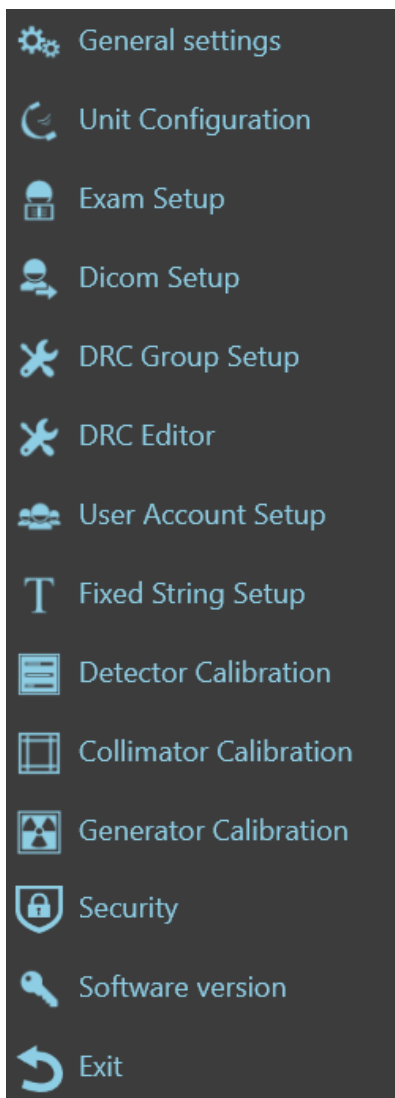

- accessed after logging in as ADVANCED:

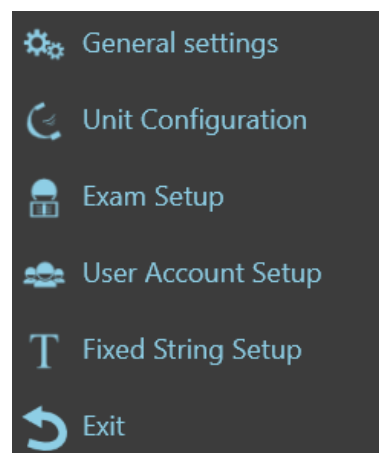

4.1.1 LOGIN

- When the LOG-IN page appears, log in as:
 - **Administrator**, by entering the technical password: *********.
(this password is provided by the manufacturer on request).
 - **Advanced**, by entering the default technical password: **12345678**.

Note: for higher safety, it is recommended to change the default Advanced user during installation.

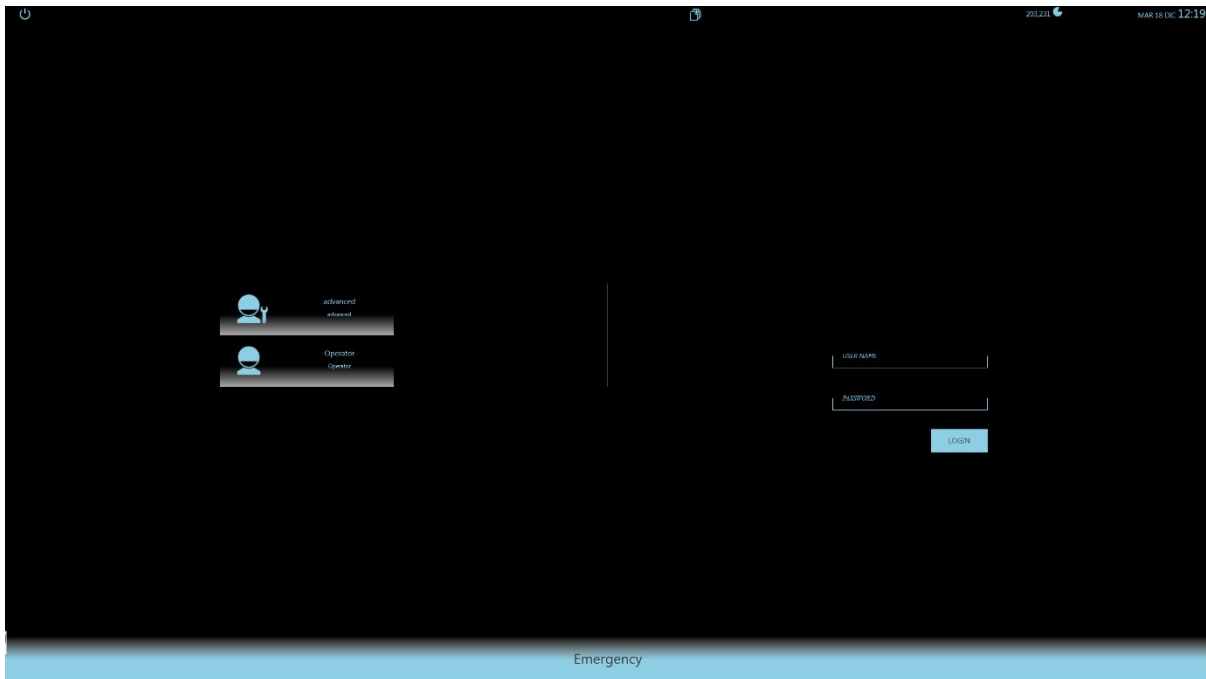

4.2 GENERAL SETTINGS

General settings:

GENERAL		AUTO DELETE	
STATION DESCRIPTION			
INSTITUTION NAME	HOSPITAL	MANUFACTURER	ATS Srl
STATION NAME	C ARM FP-S	MODEL	ARCO FP-S
TECHNICAL CONFIGURATION			
LANGUAGE *	Italiano	KEYBOARD AND CULTURE INFO	it-IT: Italian - Italy
DEMO MODE *	<input type="checkbox"/>	DEBUG MODE	<input checked="" type="checkbox"/>
SNAPSHOT SPECIFIC CONFIGURATION			
MIN DOSE ACCEPTANCE	50	MAX DOSE ACCEPTANCE	200 %
DOSE ROI REDUCTION FACTOR	25		%
DETECTOR SENSITIVITY			
FLUORO DETECTOR SENSITIVITY lsb/nGy	20.00	SNAPSHOT DETECTOR SENSITIVITY lsb/nGy	2.5
ENABLE DOWNSIZE ON ROTATION	<input type="checkbox"/>	DOSE DAP UNIT	<input checked="" type="text" value="µGy*m²"/>
TRANSPARENT COLLIMATOR PREVIEW	<input checked="" type="checkbox"/>	TEMPERATURE UNIT	<input checked="" type="text" value="°C"/>
ENABLE RAW SAVE	<input type="checkbox"/>	ENABLE DOSE REPORT	<input type="checkbox"/>
ENABLE AUTOMATIC DARK CALIBRATION	<input checked="" type="checkbox"/>	ENABLE DARK CALIBRATION ON NEW STUDY	<input checked="" type="checkbox"/>
* In order for the changes to take effect you need to restart the application.			

Note: in this paragraph the parameters which can also be modified by the **Advanced** user are highlighted in blue.

General Settings menu is made of two tabs:

- *General* (see Paragraph 4.2.1),
- *Auto Delete* (see Paragraph 4.2.2).

4.2.1 GENERAL

➤ **STATION DESCRIPTION:**

Option	Meaning / Settings	Notes
INSTITUTION NAME	Enter the name of the hospital/clinic where the EM equipment is installed.	This name does not appear on the screen but is needed for the DICOM services.
MANUFACTURER	Enter the name of the manufacturer of the EM equipment.	This name does not appear on the screen but is needed for the DICOM services.
STATION NAME	Name given to the EM equipment.	This name does not appear on the screen but is needed for the DICOM services.
MODEL	EM equipment model.	This name does not appear on the screen but is needed for the DICOM services.

➤ **TECHNICAL CONFIGURATION:**

Option	Meaning	Settings	Notes
LANGUAGE	Used to select the user interface language.	Choose the preferred language. <i>For a full list of available languages, please contact the manufacturer.</i>	The technical installation and maintenance menus are only provided in English.
KEYBOARD AND CULTURE INFO	Used to select the geographical area where the EM equipment is installed.	Select one of the areas given.	This setting determines the date format, the decimals format and the virtual keyboard layout.
DEMO MODE	Used to enable the DEMO mode.	Do not select.	This option is only used for demonstrations of the EM equipment during conferences.
DEBUG MODE	Used to create LOG and DUMP folders.	Do not select.	Only used by the Technical Service.

➤ **SNAPSHOT (DIGITAL RADIOGRAPHY) SPECIFIC CONFIGURATION:**

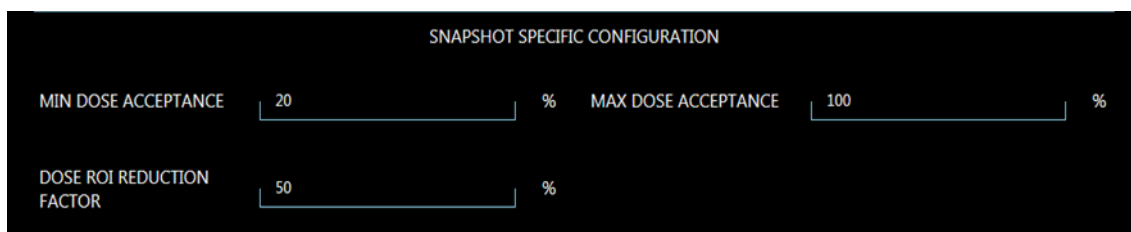

This lets you set the parameters for the X-ray dose exposure index in radiography mode (EXPOSURE INDEX).

The X-ray dose depends on the image levels and the sensitivity of the detector.

Option	Meaning	Settings	Notes
MIN DOSE ACCEPTANCE %	X-ray dose percentage compared to the value expected for the exam. The image will be "under-exposed" if the actual value is below this.	Typical value 25%	The EI and DI values are shown in blue on the monitor if the detected X-ray dose is below the value set here.
MAX DOSE ACCEPTANCE %	X-ray dose percentage compared to the value expected for the exam. The image will be "over-exposed" if the actual value is above this.	Typical value 300%	The EI and DI values are shown in red on the monitor if the detected X-ray dose is above the value set here.
DOSE ROI REDUCTION FACTOR %	This setting determines the size of the X-ray dose reading area, starting from the image processing ROI.	Typical value 30%	The image levels are read within the image processing ROI. If, for example, you set this at 30%, the calculation will be based on an area 30% smaller than the processing ROI.

➤ **DETECTOR SENSITIVITY:**

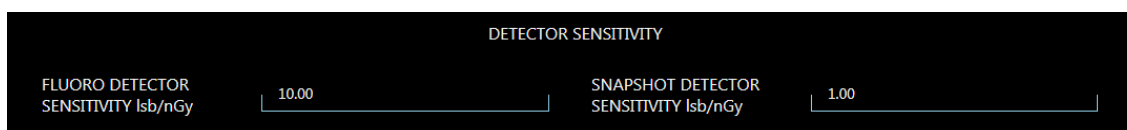

Option	Meaning	Settings	Notes
FLUORO	Sensitivity of the detector in fluoroscopy acquisition modes.	26.9 lsb/nGy (typ)	These values are set in the factory during the calibration of the EM equipment.
SNAPSHOT	Sensitivity of the detector in Digital Radiography	1.78 lsb/nGy (typ)	

➤ **IMAGE OPTION AND UNIT OF MEASURE:**

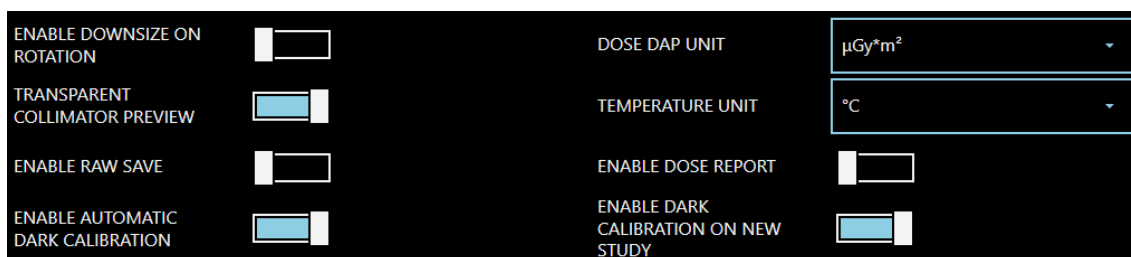

Option	Meaning	Settings	Notes
ENABLE DOWNSIZE ON ROTATION	<p>DISABLED: when rotated, the image dimensions are not changed. Depending on the angle of rotation, part of the corners of the image will be outside the screen (not displayed).</p> <p>ENABLED: when rotated, the image dimensions are reduced to allow you to see the full image.</p>	Enable or disable this function to suit the preferred mode.	
TRANSPARENT COLLIMATOR PREVIEW	<p>DISABLED: when a virtual collimation is performed on the LIH, it is shown in black, getting dark the part of image that lies outside the collimation.</p> <p>ENABLED: when a virtual collimation is performed on the LIH, it is shown transparent, giving a glimpse of the part of image that lies outside the collimation.</p>	Enable or disable this function to suit the preferred mode.	
DOSE DAP UNIT	Set dose measuring unit.	Choose among μGy*m² and mGy*cm² .	
TEMPERATURE UNIT	Set the unit of measure for the temperature of the x-ray monoblock.	Choose among °C and °F .	
ENABLE RAW SAVE	<p>DISABLED: it will not be possible to export the images on USB devices with the file extension .raw</p> <p>ENABLED: is will be possible to export the images on USB devices with the file extension .raw</p>	Enable or disable this function to suit the preferred mode.	
ENABLE DOSE REPORT	When enabled, it allows to create the Dose Report image, containing data about study and the dose gave to the patient.	Enable or disable this function to suit the required mode.	See Paragraph 3.7.2, Part 2 of the User Manual.
ENABLE AUTO DARK CALIBRATION	The system automatically calibrates the Offset of the detector (<i>Dark Calibration</i>) in background.	To be kept enabled .	See Paragraph 2.2.4.1, Part 2 of the User Manual.
ENABLE DARK CALIBRATION ON NEW STUDY	The system automatically calibrates the Offset of the detector (<i>Dark Calibration</i>) also when a new study is created.	Enable or disable this function to suit the preferred mode.	See Paragraph 2.2.4.1, Part 2 of the User Manual.

4.2.2 AUTO DELETE

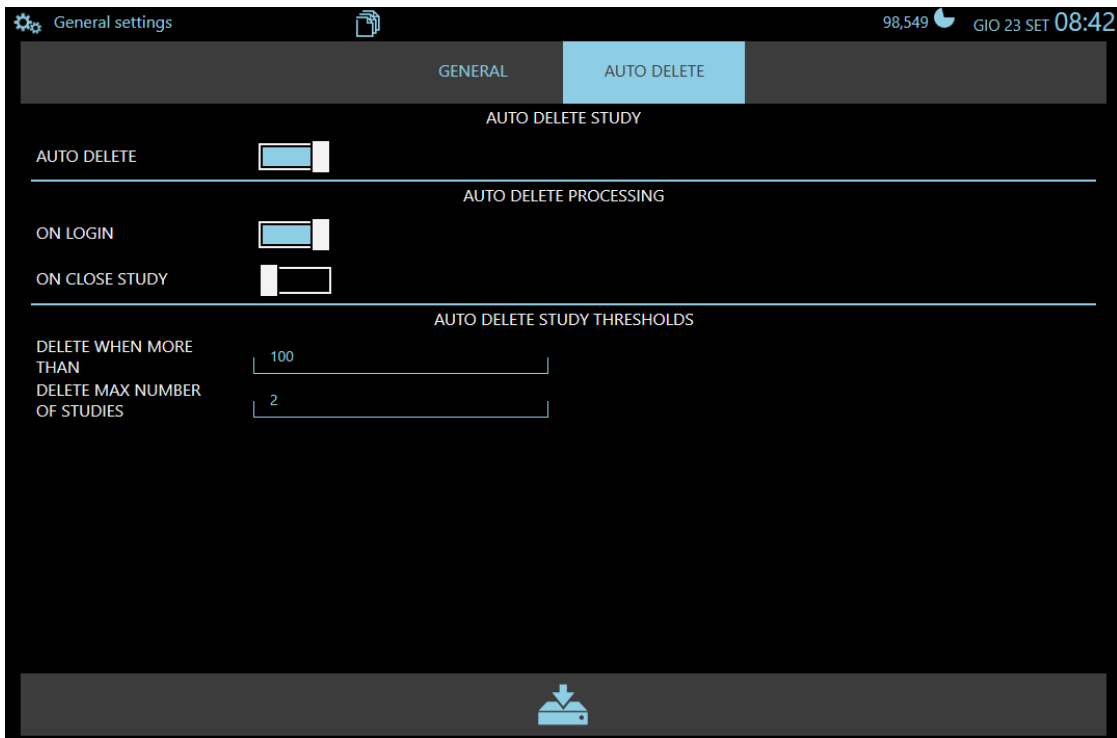

Option	Meaning	Settings	Notes
AUTO DELETE	Activation of the automatic deletion request for older studies.	On / Off	
ON LOGIN	Setting the request to delete studies at login.	On / Off	
ON CLOSE STUDY	Setting the request for deletion of studies when closing a study.	On / Off	
DELETE WHEN MORE THAN	Threshold for activating the automatic deletion request for older studies.		
DELETE MAX NUMBER OF STUDIES	Maximum number of studies to be deleted.		

4.3 UNIT CONFIGURATION

Unit Configuration is composed by the following tabs:

- Unit Configuration (see Paragraph 4.3.1),
- Sound Control (see Paragraph 4.3.2).

The screenshot shows a configuration interface with two tabs: 'UNIT CONFIGURATION' (selected) and 'SOUND CONTROL'. The 'UNIT CONFIGURATION' tab is divided into three sections:

- CTBK CONNECTION PARAMETERS:** CTBK IP ADDRESS: 192.168.3.2, CTBK IP PORT: 35000.
- DETECTOR CONNECTION PARAMETERS:** DETECTOR IP ADDRESS: 192.168.0.2, DETECTOR IP PORT COMMUNICATION: 30000.
- UNIT CONFIGURATION:**
 - DETECTOR MODEL: 3030S-AU
 - ANODE TYPE: RTM 70 H Rotating Anode
 - MAINS: 120 V
 - LASER: (checked), Laser Time (s): 60
 - SYSTEM DATE (24H Format): 30/05/2022, 15:03:51, and a 'SET' button.

4.3.1 UNIT CONFIGURATION

➤ CTBK CONNECTION PARAMETERS

The screenshot shows the 'CTBK CONNECTION PARAMETERS' section with the following values:

- CTBK IP ADDRESS: 192.168.3.2
- CTBK IP PORT: 35000

Option	Meaning	Settings	Notes
CTBK IP ADDRESS	IP Address of the CTBK board.	Set: 192.168.3.2	
CTBK IP PORT	IP Port used for communication with CTBK board.	Set: 35000	

➤ DETECTOR CONNECTION PARAMETERS

The screenshot shows the 'DETECTOR CONNECTION PARAMETERS' section with the following values:

- DETECTOR IP ADDRESS: 192.168.0.2
- DETECTOR IP PORT COMMUNICATION: 30000

Option	Meaning	Settings	Notes
DETECTOR IP ADDRESS	IP Address of the detector	Set: 192.168.0.2	
DETECTOR IP PORT COMMUNICATION	IP Port used for communication with the flat panel detector.	Set: 30000	

➤ **EQUIPMENT CONFIGURATION PARAMETERS**

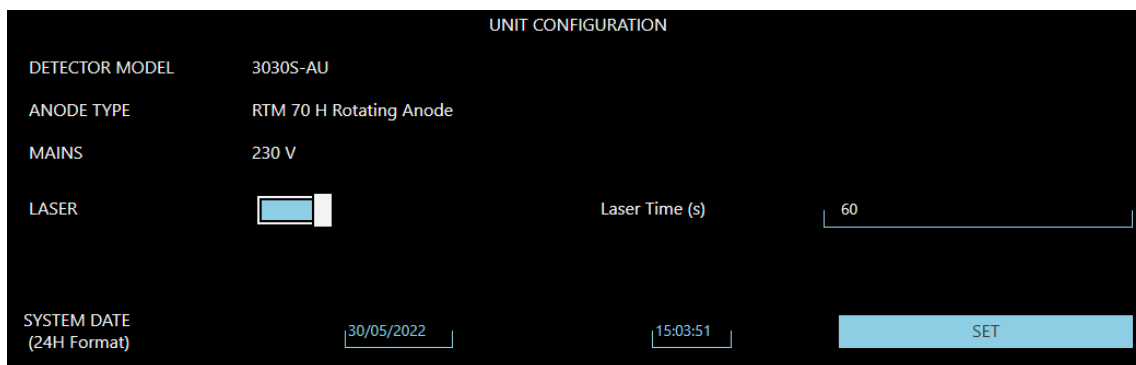

Option	Meaning	Settings	Notes
DETECTOR MODEL	Indicates the FPD model present on the EM equipment.		
ANODE TYPE	Indicates the anode type present on the equipment.		
MAINS	Indicates the voltage of the power mains supplying the equipment: 120 V or 230 V .		
LASER	Centering laser modules.	Enable if the laser option is present.	
LASER TIME (s)	Power on time of laser pointers.	Range: 60÷300 seconds	
SYSTEM DATE (24H format)	Function to set a different date or time than those currently shown on the monitor.	Enter the correct date and time.	

4.3.2 SOUND CONTROL

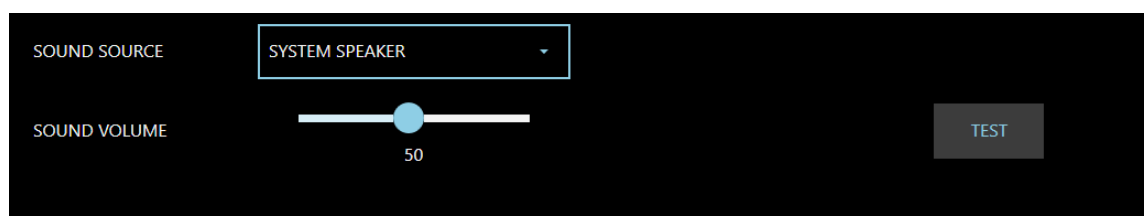

Option	Meaning	Settings	Notes
SOUND SOURCE	Source of the sound that warns that the X-ray emission is in progress.	Select between: - CTBK - SYSTEM SPEAKER	
SOUND VOLUME	Option active only if SYSTEM SPEAKER is selected as the sound source. Allows the sound volume to be adjusted.	0 ÷ 100	Press the TEST button to check the set volume.

4.4 EXAM SETUP

The equipment is configured with the default exams listed in *paragraph 2.2.5.1, Part 2 of the User Manual*.

When selecting the exam on the Control Panel, the main acquisition and image processing parameters will be automatically set to suit the specific exam.

The exams are pre-set in the factory to provide a typical equipment configuration.

When installing the equipment in a hospital, the installer and the user must check these settings and, if necessary, adjust them to suit the specific applications foreseen.

The following page appears when you open the EXAM SETUP menu:



Note: in the following paragraphs, the parameters which can also be modified by the **Advanced** user are highlighted in blue.

4.4.1 PROGRAMMABLE PARAMETERS

Select the exam that you want to customize from the drop-down list. The following parameters can be set for each exam:

GENERAL:

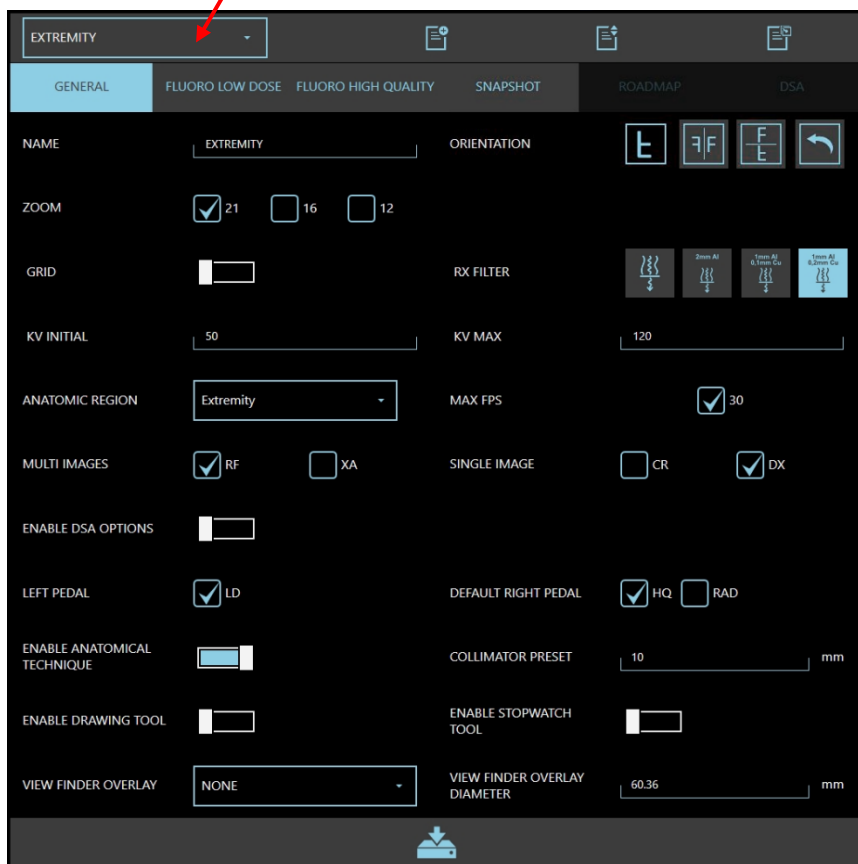

Option	Meaning	Settings	Notes	
NAME	Exam name	max 30 characters		
ORIENTATION	Orientation of the image (inverted and/or rotated)	Vertical image flip Horizontal image flip Image rotation by 90°	Orientation set when you open an exam.	
ZOOM	FPD PaxScan 3030DXV	Detector acquisition field	30cm x 30cm 21cm x 21cm 16cm x 16cm	Field set when you open an exam.
	FPD PaxScan 2121DXV	Detector acquisition field	21cm x 21cm 16cm x 16cm 12cm x 12cm	Field set when you open an exam.
GRID	Anti-scatter grid	Yes / No	The grid must be manually inserted/removed. An exam can only be performed with the grid inserted/removed as set here. If not, the equipment generates an alarm and makes X-ray emission impossible.	
RX FILTER	Additional X-ray beam filter. Useful if you need to reduce the dose given to the patient.	No filter Filter: 1mm Al + 0.1mm Cu Filter: 1mm Al + 0.2mm Cu Filter: 2mm Al	The filter is inserted automatically by the equipment. It cannot be changed during a study.	

kV INITIAL	kV value automatically set on opening the exam	40 - 120kV	The kV value during an exam is adjusted automatically (or manually by the operator) to suit the anatomic region.
kV MAX	Max permissible kV value that can be set (automatically or manually) during the exam	60 - 120kV	
ANATOMIC REGION	Anatomic region being scanned	Select any of those in the list.	This setting is used by the DICOM STORE and DICOM RDSR services.
MAX FPS	Indication of the maximum number of frames per second allowed by the equipment.	30 FPS	
MULTI IMAGES	Definition of the DICOM image type used for runs	RF or XA	These parameters define the type of DICOM image that will be used by default, unless specified for each single study.
SINGLE IMAGE	Definition of the DICOM image type used for a single image	CR or DX	
ENABLE DSA OPTIONS	To enable DSA functions.	Yes / No	
LEFT PEDAL	Low Dose fluoroscopy mode is associated to left pedal as a default.	LD Fluoroscopy.	The same acquisition modality is associated to the lateral button of the handswitch.
DEFAULT RIGHT PEDAL	It allows to associate one of the other acquisition modalities to the right pedal.	HQ Fluoroscopy or RAD. If enabled, it is possible to associate even the modes Roadmap or DSA Fluoroscopy.	The same acquisition modality is associated to double-click button of the handswitch. Modification of this setting is possible temporarily but will be limited to the current exam, directly on the Control Panel (see Paragraph 2.3.1, Part 2 of User Manual).
ENABLE ANATOMICAL TECHNIQUE	This function allows to enable the exam which has been just set, making it available from the Control Panel.	Yes / No	If the exam is not enabled, it will not be shown on the Control Panel.
COLLIMATOR PRESET	This function allows to set an opening default value for the collimator square iris. It will be possible to use this value, during an exam, by touching the relevant key on the Control Panel (see Paragraph 1.3.1.1, Part 1 of the User Manual).	Enter the required value, range: 10 - 300 mm. Entering 0 , the function is disabled and the relevant button will not be shown on the Control Panel.	The function involves only the collimator square iris.
ENABLE DRAWING TOOL	It enables or disables the Live Drawing function on Control Panel and Live Monitor. See Paragraph 3.1.2, Part 2 of the User Manual.	Yes / No	If the function is disabled, the relevant button will not be shown on the Control Panel and Live Monitor.
ENABLE STOPWATCH TOOL	It enables or disables the Stopwatch function on Control Panel and Live Monitor. See Paragraph 2.3.11, Part 2 of the User Manual.	Yes / No	If the function is disabled, the relevant button will not be shown on the Control Panel and Live Monitor.

VIEW FINDER OVERLAY	It is possible to activate a sight (crosshair or globe sight) that will be shown on the image central part.	None or crosshair or globe sight .	None: the function is disabled and the relevant button will not be shown on the Control Panel. See Paragraph 2.2.4.2, Part 2 of the User Manual.
VIEW FINDER OVERLAY DIAMETER	Set overlay diameter of the sight (in mm).	30 ÷ 80 mm	

LOW DOSE FLUOROSCOPY:

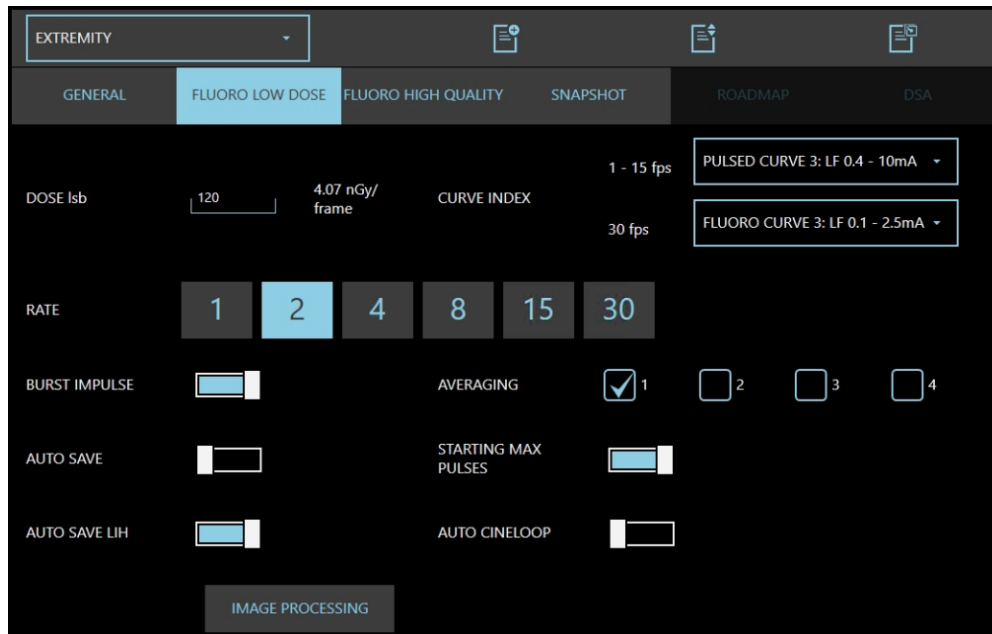

LOW DOSE FLUOROSCOPY parameters

Option	Meaning	Settings	Notes
DOSE lsb	Reference dose value expressed as image levels (lsb)	50 ÷ 1000 (typ.330)	330 lsb corresponds to 12 nGy/i
CURVE INDEX Rotating anode	Select the mA curve that will be associated to the acquisition mode: 1-15fps: Pulsed Curve 30fps: Continuous Curve	1-15fps P. Curve 1: SF 0.4-10 mA P. Curve 2: SF 1.6-40 mA P. Curve 3: LF 0.4-10 mA P. Curve 4: LF 1.6-40 mA 30fps C. Curve 1: SF 0.1-2.5 mA C. Curve 2: SF 0.2-5 mA C. Curve 3: LF 0.1-2.5 mA C. Curve 4: LF 0.2-5 mA	
RATE	Acquisition rate set when the exam is selected.	Choose between shown values: 1 – 2 – 4 – 8 – 15 – 30	The operator can change the acquisition rate during the exam.

AVERAGING	This function allows to have a single image as a result of the sum of 2,3 or 4 images (depending on the Averaging factor set), in order to improve image quality.	1 – 2 – 3 – 4 (Averaging=1 means the function is disabled).	When the function is enabled, the Max acquisition rate available decreases: the product of the frame rate multiplied the averaging value must be lower than Max FPS set for the exam. E.G.: if Max FPS=25 and Averaging=4 , max frame rate available is 6 (6x4=24).
BURST IMPULSE	The function will increase the acquisition rate to the maximum during the Automatic Dose Control regulation, in order to make the correction faster. When the optimal dose value is reached, the rate will decrease to the set value.	Yes / No	.
STARTING MAX PULSES	The equipment starts every acquisition, for a duration of 0.6 seconds, at the maximum value regardless of the set rate.	Yes / No	This is a useful function if you have set both a high recursive filter value (i.e.: k = 6-12) and a low acquisition rate, as it lets you obtain immediately an image without noise.
AUTO SAVE	Automatic saving to hard disk of all the image acquired.	Normally enabled.	As an alternative to AUTO SAVE LIH
AUTO SAVE LIH	Automatic saving to hard disk of the last image hold (LIH).	Normally NOT enabled.	As an alternative to AUTO SAVE
AUTO CINE LOOP	Automatic activation of the cine loop after acquisition of a run of images	Yes / No	This function is only active if the images in the run have been saved to hard disk
IMAGE PROCESSING	Opening of the image processing parameters setup menu in continuous fluoroscopy	See par. 4.4.2	

HIGH QUALITY FLUOROSCOPY:

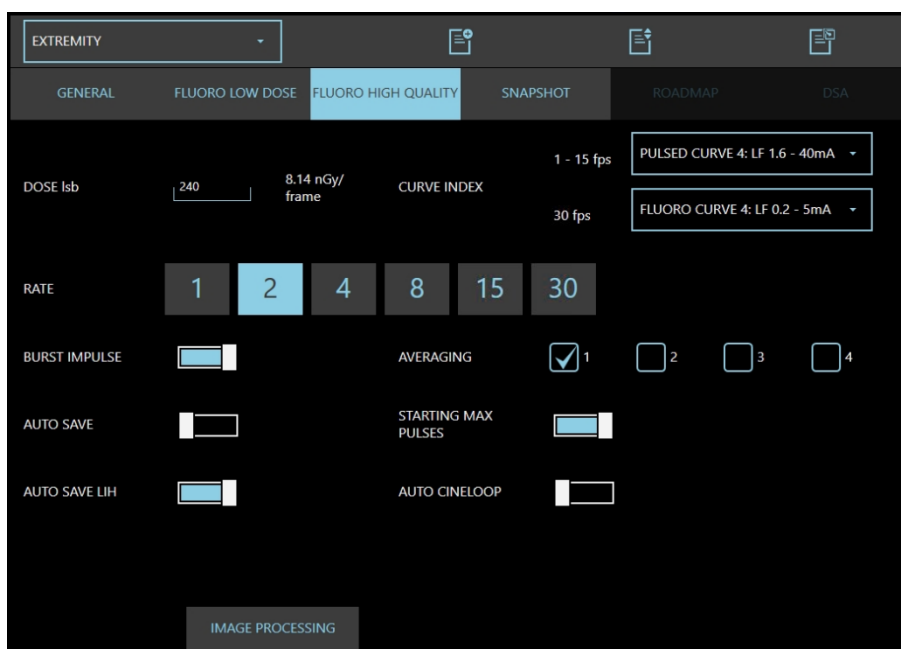

HIGH QUALITY FLUOROSCOPY parameters:

Option	Meaning	Settings	Notes
DOSE lsb	Reference dose value expressed as image levels (lsb)	50 ÷ 1000 (typ.330)	330 lsb corresponds to 12 nGy/i
CURVE INDEX Rotating anode	Select the mA curve that will be associated to the acquisition mode: 1-15fps: Pulsed Curve 30fps: Continuous Curve	1-15fps P. Curve 1: SF 0.4-10 mA P. Curve 2: SF 1.6-40 mA P. Curve 3: LF 0.4-10 mA P. Curve 4: LF 1.6-40 mA 30fps C. Curve 1: SF 0.1-2.5 mA C. Curve 2: SF 0.2-5 mA C. Curve 3: LF 0.1-2.5 mA C. Curve 4: LF 0.2-5 mA	
RATE	Acquisition rate set when the exam is selected.	Choose between shown values: 1 – 2 – 4 – 8 – 15 – 30	The operator can change the acquisition rate during the exam.
AVERAGING	This function allows to have a single image as a result of the sum of 2,3 or 4 images (depending on the Averaging factor set), in order to improve image quality.	1 – 2 – 3 – 4 (Averaging=1 means the function is disabled).	When the function is enabled, the Max acquisition rate available decreases: the product of the frame rate multiplied the averaging value must be lower than Max FPS set for the exam. E.G.: if Max FPS=25 and Averaging=4 , max frame rate available is 6 (6x4=24).
BURST IMPULSE	The function will increase the acquisition rate to the maximum during the Automatic Dose Control regulation, in order to make the correction faster. When the optimal dose value is reached, the rate will decrease to the set value.	Yes / No	

STARTING MAX PULSES	The equipment starts every acquisition, for a duration of 0.6 seconds, at the maximum value regardless of the set rate.	Yes / No	This is a useful function if you have set both a high recursive filter value (i.e.: k = 6-12) and a low acquisition rate, as it lets you obtain immediately an image without noise.
AUTO SAVE	Automatic saving to hard disk of all the image acquired.	Normally enabled.	As an alternative to AUTO SAVE LIH
AUTO SAVE LIH	Automatic saving to hard disk of the last image hold (LIH).	Normally NOT enabled.	As an alternative to AUTO SAVE
AUTO CINE LOOP	Automatic activation of the cine loop after acquisition of a run of images	Yes / No	This function is only active if the images in the run have been saved to hard disk
IMAGE PROCESSING	Opening of the image processing parameters setup menu in continuous fluoroscopy	See par. 4.4.2	

SNAPSHOT (DIGITAL RADIOGRAPHY):

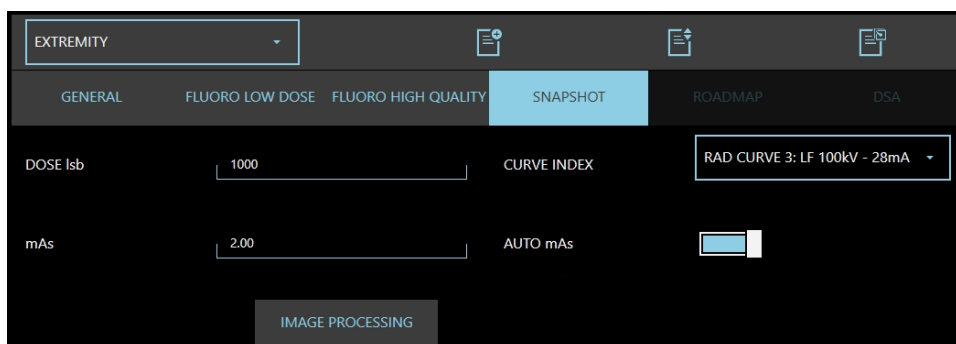

DIGITAL RADIOGRAPHY parameters:

Option	Meaning	Settings	Notes
DOSE lsb	Reference dose value expressed as image levels (lsb)	100 - 5000 (typ. 1000)	
CURVE INDEX Rotating anode	Select the mA curve for this acquisition mode.	Mains power supply <u>230 VAC</u> : Rad Curve 1: SF 100 kV – 28 mA Rad Curve 2: SF 100 kV – 40 mA Rad Curve 3: LF 100 kV – 28 mA Rad Curve 4: LF 100 kV – 40 mA Mains power supply <u>120 VAC</u> : Rad Curve 1: SF 100 kV – 14 mA Rad Curve 3: LF 100 kV – 14 mA	
mAs	Establishes the default mAs value when the Auto mAs function is not selected	0,5 - 50 (with mains power supply 230 VAC) 0,5 - 25 (with mains power supply 120 VAC)	You can alter the value during an exam.
AUTO mAs	If enabled, the mAs are automatically set to suit the set working dose.	Yes / No	You can alter the value during an exam.
IMAGE PROCESSING	Opening of the image processing parameters setup menu – radiology	See par. 4.4.2	

4.4.1.1 DSA PROGRAMMABLE PARAMETERS

The DSA function offers two possible image acquisition modes:

- Road Mapping
- DSA fluoroscopy.

Road Mapping mode produces subtracted images that let you observe and adjust the position of a catheter in the blood vessel during a fluoroscopic exam.

DSA fluoroscopy is a technique that lets you see a blood vessel distinctly within bone structures and soft tissues. Once the contrast agent has been injected, the images will be shown subtracted from a mask image (acquired before injecting the contrast agent).

These functions can be enabled for each of the six exam types that can be set in Exam Setup; check the relevant option in the **GENERAL** window to enable DSA functions (see the beginning of paragraph 4.4.1 in this chapter).

To set the parameters for each function:

ROADMAP:

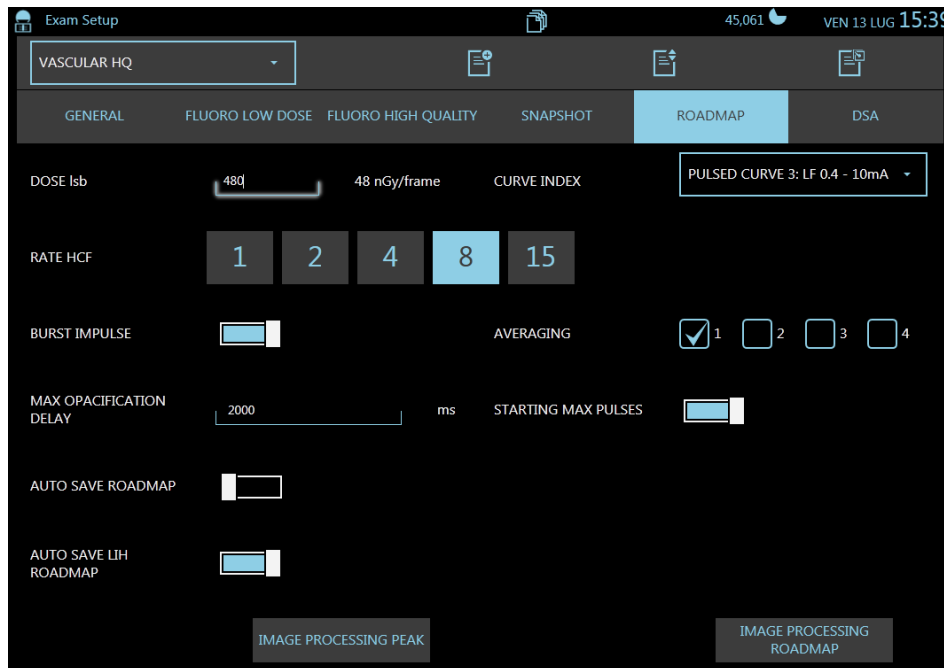

ROADMAP Parameters:

Option	Meaning	Settings	Notes
DOSE Isb	Reference dose value expressed as image levels (Isb)	50 - 2000 (typ. 1320)	1320 Isb corresponds to 48 nGy/i
CURVE INDEX Rotating anode	Select the mA curve for this acquisition mode.	Pulsed curve 1: SF 0.4 - 10 mA Pulsed curve 2: SF 1.6 - 40 mA Pulsed curve 3: LF 0.4 - 10 mA Pulsed curve 4: LF 1.6 - 40 mA	

RATE	Acquisition rate set when the exam is opened. Rate values available depend on MAX FPS value set in GENERAL .	Choose between shown values: 1 – 2 – 4 – 8 – 15	The operator can change the rate values on opening the exam.
AVERAGING	This function allows to have a single image as a result of the sum of 2,3 or 4 images (depending on the Averaging factor set), in order to improve image quality.	1 – 2 – 3 – 4 (Averaging=1 means the function is disabled).	When the function is enabled, the Max acquisition rate available decreases: the product of the frame rate multiplied the averaging value must be lower than Max FPS set for the exam. E.G.: if Max FPS=25 and Averaging=4 , max frame rate available is 6 (6x4=24).
BURST IMPULSE	Not available in RoadMap mode	Keep DISABLED.	
STARTING MAX PULSES	The equipment starts every acquisition at the Max FPS set for this exam (15 or 25 fps), for 0.6 seconds, regardless of the set rate.	Typically enabled.	
MAX OPACIFICATION DELAY	Delay time between x-ray exposure start and Max Opacification image acquisition (stated in msec).	Typ: 2000	Time the system requires to automatically adjust the kVs value.
AUTO SAVE ROADMAP	If enabled, all the images in the run will be saved to hard disk.	Yes / No	As an alternative to AUTO SAVE LIH ROADMAP
AUTO SAVE LIH ROADMAP	If enabled, only the Last Image Hold (LIH) image is saved to hard disk.	Yes / No	As an alternative to AUTO SAVE ROADMAP
IMAGE PROCESSING PEAK	Opens the post processing parameters setting menu for Max Opacification images.	See par. 4.4.2	
IMAGE PROCESSING ROAD MAP	Opens the post processing parameters setting menu for ROADMAP images.	See par. 4.4.2	

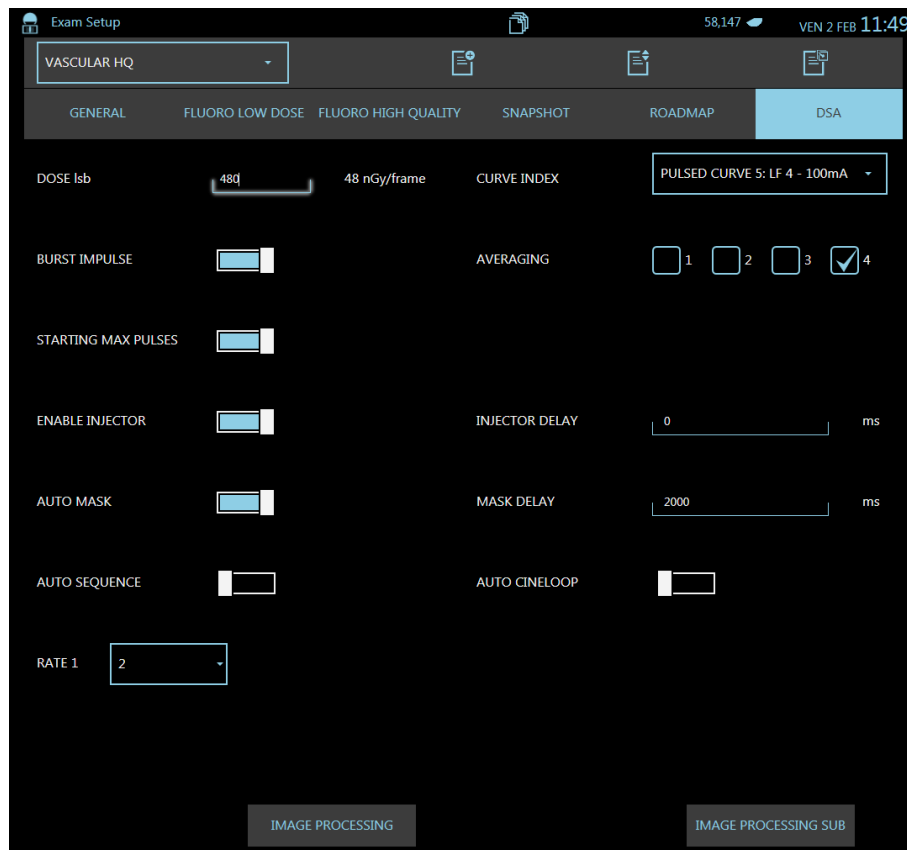
DSA:

You can program some specific parameters for a DSA exam during installation. These are automatically set once you open DSA acquisition mode:

- **Phase duration**, defined by duration and pulse rate; the exam can be set to have one or two acquisition phases, each one with its own acquisition rate. The exam ends 30 seconds after the x-ray emission started or when the x-ray command is released.
- **Duration of the phases.** The exam can have a maximum duration of 40 seconds (up to 10 seconds head start for the injector, if required, and up to 30 seconds X-ray emission).
- **Automatic injector control:** to anticipate/delay the moment that the injector starts with respect to the start of X-ray emission.
- **Mask image uptake delay** from the start of X-ray exposure (0 – 25 seconds).

During the exam, the operator can adjust the default parameters directly from the Control Panel to suit actual needs.

DSA Fluoroscopy Parameters

Option	Meaning	Settings	Notes
DOSE lsb	Reference dose value for DSA fluoroscopy, expressed as image levels (lsb)	50 - 2000 (typ. 1320)	1320 lsb corresponds to 48 nGy/i
CURVE INDEX	Rotating anode	Select the mA curve for this acquisition mode. Pulsed curve 1: SF 0.4 - 10 mA Pulsed curve 2: SF 1.6 - 40 mA Pulsed curve 3: LF 0.4 - 10 mA Pulsed curve 4: LF 1.6 - 40 mA	
	Fixed anode	Select the mA curve for this acquisition mode. Pulsed curve 1: SF 0.4-10 mA Pulsed curve 3: LF 0.4-10 mA Pulsed curve 4: LF 0.8-20 mA	
AVERAGING	This function allows to have a single image as a result of the sum of 2,3 or 4 images (depending on the Averaging factor set), in order to improve image quality.	1 - 2 - 3 - 4 (Averaging=1 means the function is disabled).	When the function is enabled, the Max acquisition rate available decreases: the product of the frame rate multiplied the averaging value must be lower than Max FPS set for the exam. E.G. : if Max FPS=25 and Averaging=4 , max frame rate available is 6 (6x4=24).
BURST IMPULSE	The function will increase the acquisition rate to Max FPS during the Automatic Dose Control regulation, in order to make the correction faster. When the optimal dose value is reached, the rate will decrease to the set value.	Yes / No	The function is only active until the mask pickup.
STARTING MAX PULSES	The equipment starts every acquisition at the Max FPS set for this exam (15 or 25 fps), for 0.6 seconds, regardless of the set rate.	Typically enabled.	This is a useful function if you have set both a high recursive filter value (i.e.: k = 6-12) and a low acquisition rate, as it lets you obtain immediately an image without noise.
ENABLE INJECTOR	When this function is enabled, the operator can use an injector controlled by the system.	Yes / No	If enabled, when the exam is opened, the injector icon will be shown.
INJECTOR DELAY	Delay (positive number) or anticipation (negative number), indicated in ms, for the start of the injector with respect to the start of X-ray exposure.	From -10 to +25 seconds.	Available if ENABLE INJECTOR option is enabled.
AUTO MASK	To enable the automatic mask uptake function in the moment defined by MASK DELAY option.	Yes / No	
MASK DELAY	Delay, indicated in ms, between the X-ray exposure start and mask image acquisition.		Once the mask image has been picked up, the system shows the image in subtraction mode.
AUTO SEQUENCE	This function divides the DSA exam into two phases: the operator can set the acquisition rate and duration of each phase.		

RATE 1 RATE 2	Acquisition rate of each phase.	Choose between shown values: 1 - 2 - 4 - 8 - 15	The operator can change the rate values on opening the exam. If high mA curve is set (curve 5, 100 mA), max acquisition rate value is automatically reduced by the system (from 15 fps to 8 fps, or from 25 fps to 12 fps) in order to not overcome Reference Air Kerma Limit, stated by EN 60601-2-54 standard in 176 mGy per minute.
SPAN RATE 1	RATE 1 phase duration, in ms		
AUTO CINE LOOP	Automatic activation of the cine loop after acquisition of a run of images	Yes / No	This function is only active if the images in the run have been saved to hard disk
IMAGE PROCESSING	Opening of the DSA image processing parameters setup menu (not for subtracted images).	See par. 4.4.2	
IMAGE PROCESSING SUB	Opening of the subtracted DSA image processing parameters setup menu.	See par. 4.4.2	

4.4.2 IMAGE PROCESSING

IMAGE PROCESSING parameters can be set for each exam in each acquisition mode.

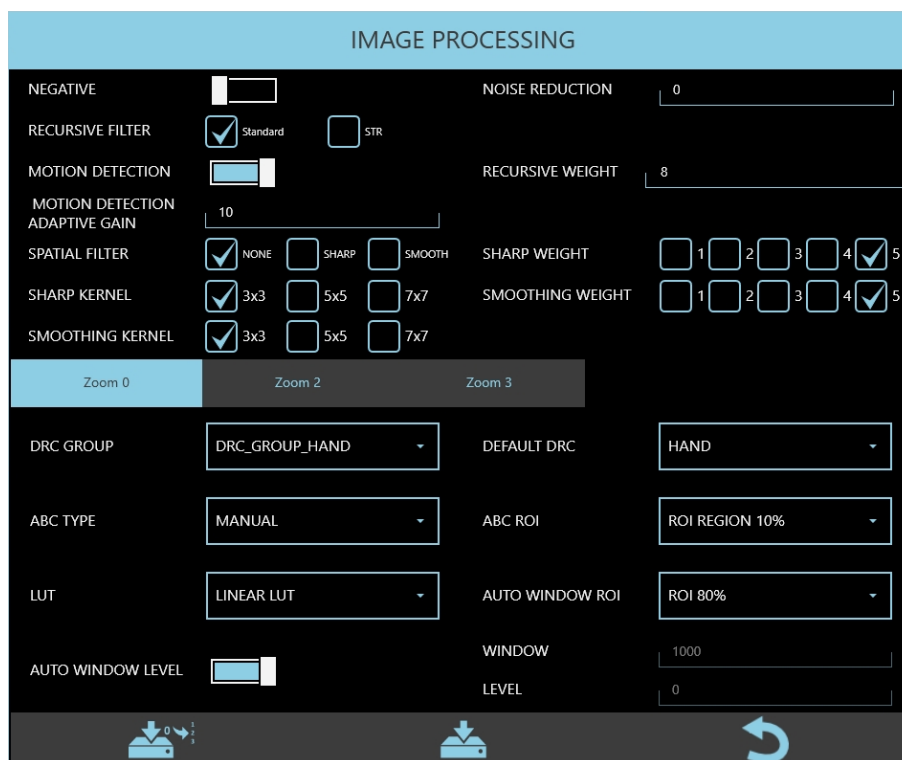

IMAGE PROCESSING parameters:

Option	Meaning	Settings	Notes
NEGATIVE	"Negative" display of the gray scale	Yes / No	Normally enabled for images acquired in digital radiography mode.
NOISE REDUCTION	Set the weight of the Noise Reduction spatial filter.	(0 - 10) 0 = function disabled, 10 = max noise reduction.	
MOTION DETECTION	Component of the noise reduction algorithm for fluoroscopy images. This reduces the time component of the recursive filter (<i>recursive filter weight</i>) in proportion to the movement detected in the image. <u>This parameter is not available for SNAPSHOT IMAGE PROCESSING.</u>	Yes / No	Used to establish whether the "MOTION DETECTION" function is active or not on opening an exam. You can alter the setting during an exam.
MOTION DETECTION ADAPTIVE GAIN	Parameter used to set how sensitive the MOTION DETECTION function should be. <u>This parameter is not available for SNAPSHOT IMAGE PROCESSING.</u>	(0 - 1000) (typ. 10)	The higher the value of this parameter, the greater the movement sensitivity.
RECURSIVE WEIGHT	Recursive filter weight for noise reduction of fluoroscopy images. <u>This parameter is not available for SNAPSHOT IMAGE PROCESSING.</u>	1 – 16 (typ. 4)	
SPATIAL FILTER	Type of default spatial filter applied on opening an exam. - Sharp for enhanced edges, - Smooth for softer edges.	You can choose between: - No filter - Sharp filter - Smooth filter (Typically, No filter)	You can alter this default setting during an exam and choose between: -no filter, or -sharp/smooth filter, as set in the next parameters
SHARP KERNEL	Kernel of the Edge Sharpening filter	You can choose between: 3 x 3 5 x 5 7 x 7	
SHARP WEIGHT	Weight of the Edge Sharpening filter	You can choose between: 1, 2, 3, 4, 5	
SMOOTHING KERNEL	Kernel of the Edge Smoothing filter	You can choose between: 3 x 3 5 x 5 7 x 7	
SMOOTHING WEIGHT	Weight of the Edge Smoothing filter	You can choose between: 1, 2, 3, 4, 5	

The following parameters are foreseen **for each detector field** (in each acquisition mode used for each exam):

Option	Meaning	Settings	Notes
DRC GROUP	The DRC GROUP containing the 3 DRC processes possible for each exam (Dynamic Range Compensation). For information on choosing the groups, see para. 4.6	Select the default DRC GROUP from among those shown.	You can alter this default setting during an exam by selecting any of the other DRC processes shown here.
DEFAULT DRC	DRC process in the selected group automatically set on opening an exam.	Select one of the 3 processes in the DRC GROUP shown.	
ABC Type	Select the preferred set for x-ray dose calculation .	Manual or Auto	AUTO: the system automatically adjusts the portion of image used to calculate, depending on the image in acquisition. MANUAL: the system uses the dimension of the ROI entered in ABC ROI field.
ABC ROI	Size of the side of the Region of Interest (ROI) used by the equipment to control the X-ray dose. The ROI is a square, centered on the image.	Select one of the options shown.	The size of the side of the ROI is expressed as a % of the size of the image on the monitor.
LUT	LUT used to display the image on the monitor	Select one of the LUT settings shown (typically, LINEAR)	
AUTO WINDOW ROI	To set the parameters for the Auto window function (this automatically calculates the W and L used to display the image on to suit the image histogram).	Select one of the settings shown.	ROI = Region of Interest, used for automatic calculation of the W and L. B and W = parameters used to calculate the W and L depending on the histogram.
AUTO WINDOW LEVEL	To enable the Auto window function. If not selected, the W and L will be fixed at the values set in the following parameters.	YES / NO (typically, YES)	
WINDOW	Setting for the W value when the Auto window is not active		
LEVEL	Setting of the L value when the Auto window is not active		

Note: the button aside allows to apply the parameters set to all detector zoom fields. This function is available only if detector nominal field is selected.



4.4.3 EXAMS MANAGEMENT

The EM equipment is provided with a set of already configured exams.

The Administrator could add new exams and modify or disable those configured by the manufacturer. While the Advanced user could change the order of the exam in the relevant list (see Paragraph 4.4.3.2 below).

4.4.3.1 CREATING A NEW EXAM

Pressing the relevant key, the new exam creation page is opened. You can set:

- the exam name,
- the exam parameters as explained in **previous paragraphs 4.4.1 and 4.4.2.**

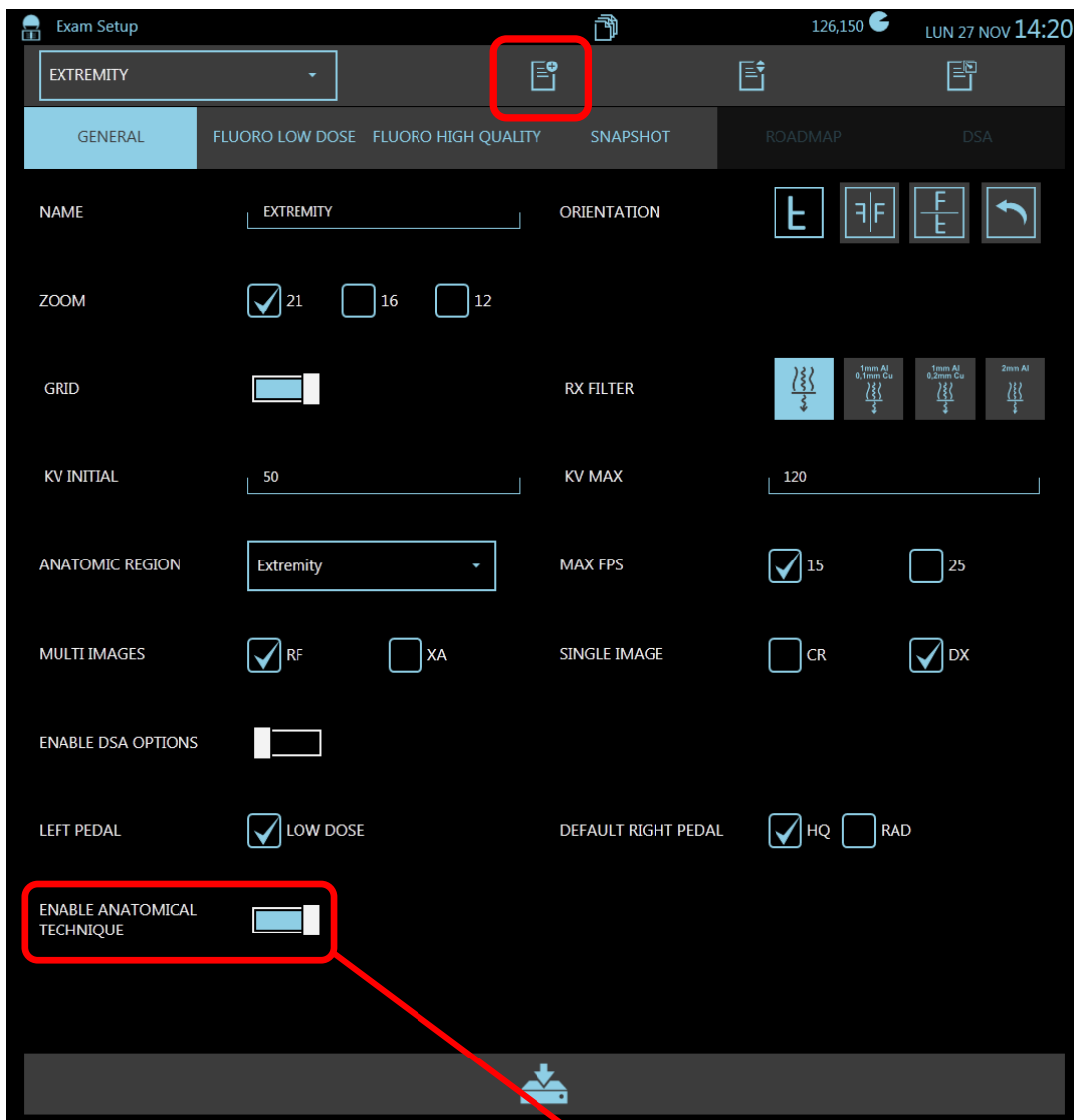

Once the exam has successfully been created, use the **relevant key to enable it** and make it available on the Control Panel.

4.4.3.2 ORGANIZE THE EXAM LIST

The EM equipment stores all the exams created (enabled or not), in a same list. Only those enabled will be shown in the list of the **Control Panel**.

Exams order in the list is the same presented in the Control Panel.

Use the ANATOMIC TECHNIQUE ORDER (here below) to change an exam position: just select it and, using relevant tips, move it to the required position.

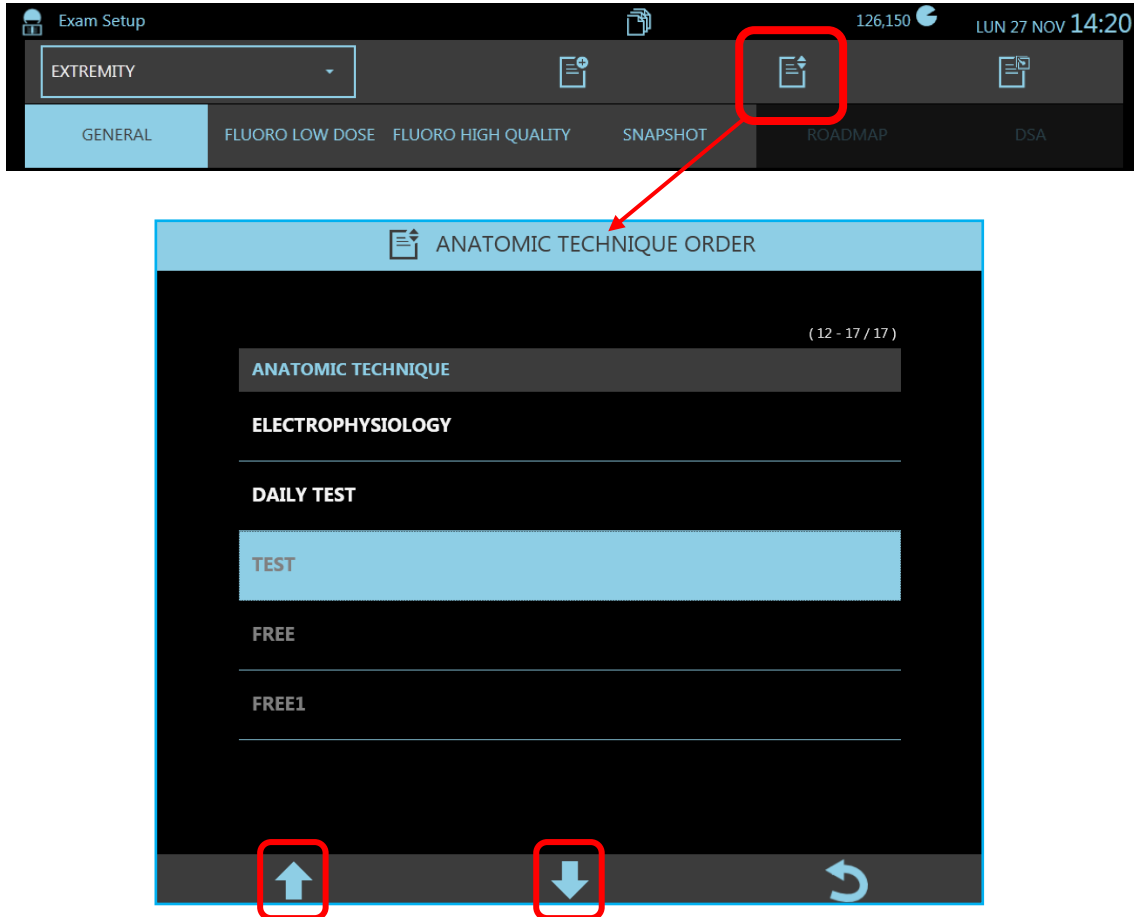

Note: enabled exams are presented in white, while those not enabled in grey.

4.4.3.3 DUPLICATE AN EXAM

This is a very useful function to create a new exam quite similar to another one already present in the list.

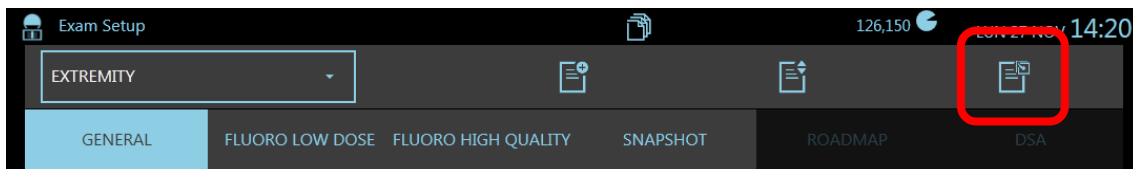

Create a new exam and press the relevant key: select from the drop-down list the exam required; this will automatically be copied. Change parameters, if needed, and save to add the exam to your list.

4.5 DICOM SETUP

Note: After connecting the EM equipment to the mains supply (see paragraph 3.2.3 above), configuration of the DICOM functions involves the following steps:

- setting of the network parameters for WINDOWS 7 (see Annex 5.4)
- definition of the remote DICOM devices and configuration of the various working modes (DICOM SETUP menu).

The DICOM setup menu has 5 sub-menus:

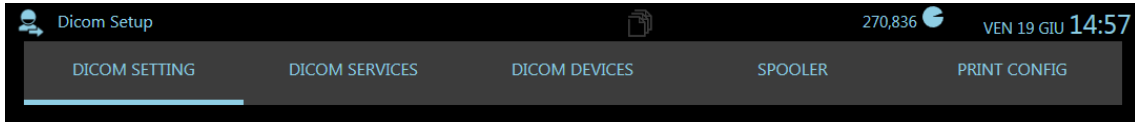

- **DICOM SETTING:** used for the general DICOM configuration of the system;
- **DICOM SERVICES:** used to set the individual services available in the system;
- **DICOM DEVICES:** used to manage the list of remote DICOM devices available;
- **SPOOLER:** used to manage the transmission of images over the network;
- **PRINT CONFIG:** used for the 4 DICOM print configurations.

4.5.1 DICOM SETTING

The **DICOM SETTING** menu is used to determine the equipment addressing. The hospital network administrator should be consulted when setting these parameters.

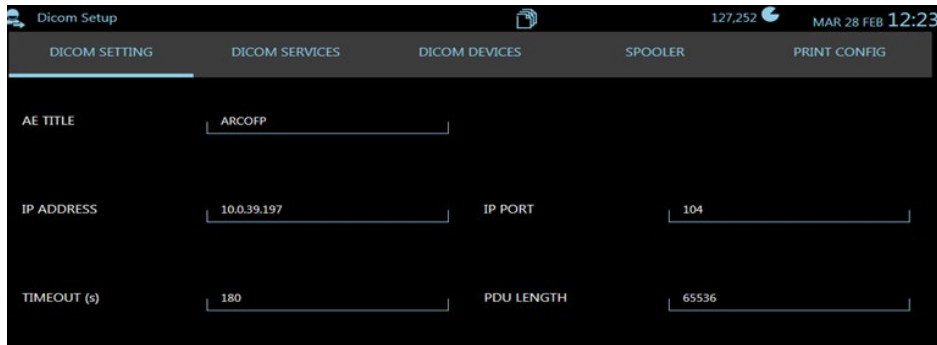

Option	Meaning	Settings	Notes
AE Title	Conventional name of device in the hospital's DICOM network.	Typically: C-ARM	
IP Address	TCP network address to be used for the DICOM services.	Defined by the network administrator. It must be equal to the network address used for the Windows operating system.	If a fixed address has not been set, the device automatically creates an address compatible with the network (based on IP address and Net Mask).
IP Port	TCP port number to be used for the DICOM services.	Typically: 104	
Timeout (s)	Time, in seconds, before the system states that transmission has failed (no answer from the DICOM server).		
PDU length		Typically: 65536	

4.5.2 DICOM SERVICES

This menu lets you configure the various DICOM services in the system.

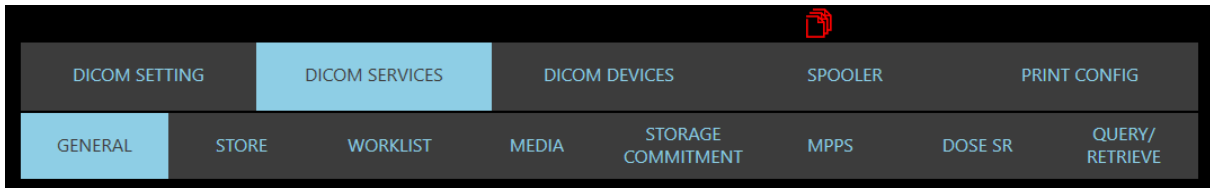

4.5.2.1 GENERAL

In the **General** folder it is possible to define the preferred operating options if the PATIENT ID and STUDY ID fields are empty.

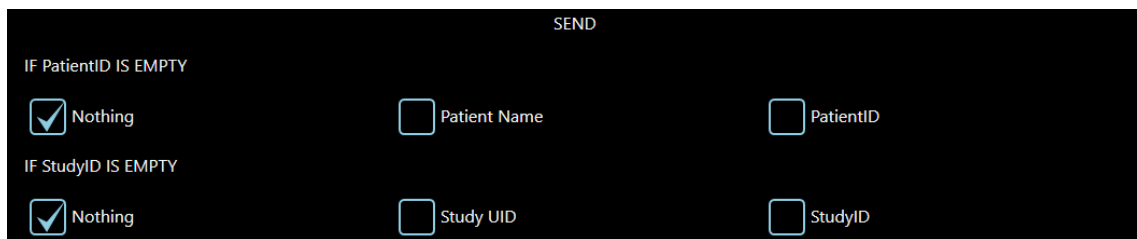

Send Options		Notes
If Patient ID is empty	<p>If the "Patient ID" parameter is not available, there are three options for this DICOM field:</p> <ul style="list-style-type: none"> - Nothing: the "Patient ID" field remains empty. - Patient name, the patient's name is entered instead. - Patient ID: the words "PATIENT ID" are entered. 	Attention: this option is applied to all Dicom services except the Media service (see Paragraph 4.5.2.4 below).
If Study ID is empty	<p>If the "Study ID" parameter is not available, there are three options for this DICOM field:</p> <ul style="list-style-type: none"> - Nothing: the "Study ID" field remains empty. - Study UID, the Study UID parameter is entered instead. - Study ID: the words "STUDY ID" are entered. 	Attention: this option is applied to all Dicom services except the Media service (see Paragraph 4.5.2.4 below).

4.5.2.2 STORE

The **Store** tab lets you set the function options (these depend on the behavior of the specific receiving device).

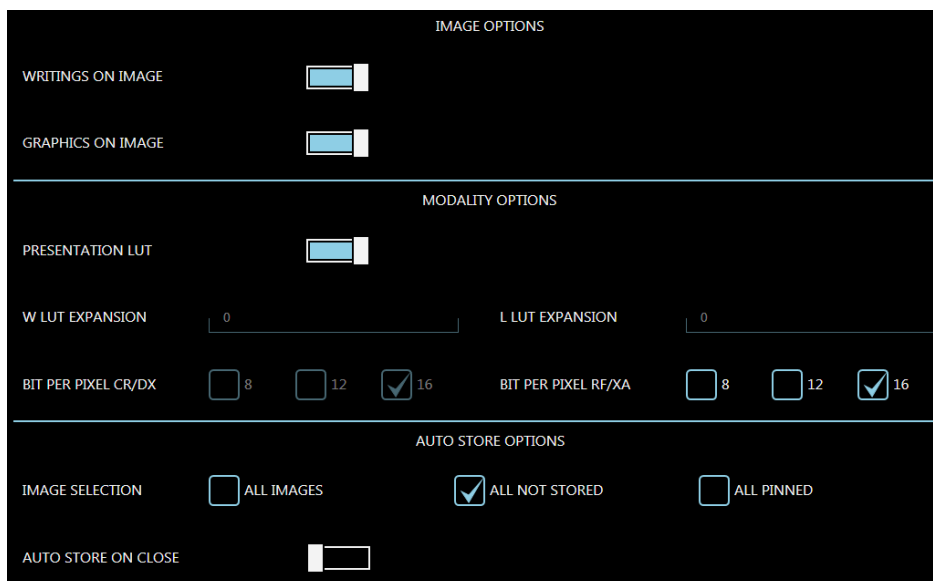

Image Options		Notes
Writings on Image	Image transferred together with its text (patient name, image nr., etc.) as shown on the monitor.	If not enabled, the image is sent without any writings. These will, in any case, be sent via the relevant DICOM fields.
Graphics on Image	Transfer of the image with overlay (text or measurements) added by the operator.	If not enabled, the image is sent without any graphic overlay.

Modality Options		Notes
Presentation LUT	Enables the "complete" transfer of the image, followed by the presentation LUT parameters.	Only suitable for DX images.
W/L LUT expansion	Option only active when the Presentation LUT option is not enabled. This lets you determine the level of the LUT expansion for the image sent to the server compared to that used for its presentation on the monitor. Possible values: 0 - 30% , towards both black (B) and white (W).	This function lets you include in the image parts of the histogram outside the image shown on the monitor.
Bits per pixel for CR/DX	The number of bits/pixels for the image being sent (CR/DX modes). Possible values: 8 - 12 - 16 bits/pixel.	The actual setting will depend on the characteristics of the server.
Bits per pixel for RF/XA	The number of bits/pixel for the image being sent (RF/XA modes). Possible values: 8 - 12 - 16 bits/pixel.	The actual setting will depend on the characteristics of the server.

Auto Store Options		Notes
Image Selection	Options: - All Images: to send all the images in the study - All not Stored: to send all the images not already sent to the server - All Pinned: to send only the images selected by the operator using the PIN function	
Autostore on Close	Enables the auto store function when the study is closed (default server).	

4.5.2.3 WORKLIST

The DICOM Worklist function is used to request a list of the studies to be performed (and the relevant procedures) from the server.

The following parameters are used to set the Worklist request.

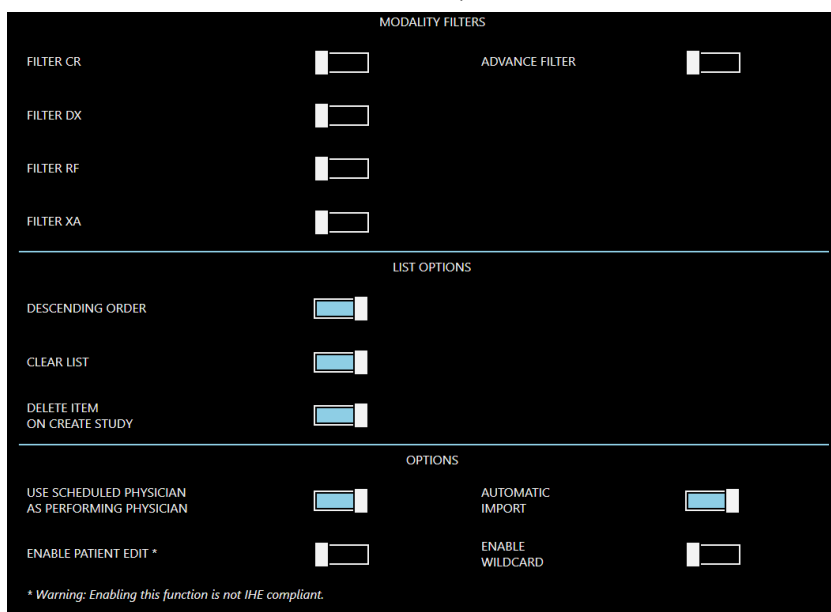

Modality Filters		Notes
Filter CR	Enables the filter for studies in CR mode.	Only exams in CR mode are requested.
Filter DX	Enables the filter for studies in DX mode.	Only exams in DX mode are requested.
Filter XA	Enables the filter for studies in XA mode.	Only exams in XA mode are requested.
Filter RF	Enables the filter for studies in RF mode.	Only exams in RF mode are requested.
Advanced Filter	Enable "Accession Number" and "Requested Procedure ID" filters to search studies in the Worklist	See Paragraph 2.2.3, Section 2 of the User Manual
More than one filter can be enabled at the same time. If no filter has been selected, the Worklist will be requested without any mode restrictions.		

List Options		Notes
Descending Order	The received studies are shown in chronological order, as per the Date-Time field (most recent first).	If not selected, the studies will appear in their order of reception.
Clear list	Used to delete the current Worklist before requesting a new one (with Get List).	If not selected, the new studies will be added to those already in the Worklist.
Clear item on create study	Used to delete the study from the Worklist once it has been created.	If not selected, the study will continue to appear in the Worklist, but marked with a check sign.

List Options		Notes
Use scheduled physician as performing physician	The name of the operator received from the Worklist (Scheduled Physician) is entered in the field indicating the operator responsible for the study (Performing Physician).	
Enable patient edit	Enable the possibility to change patient's data in a study received through Worklist.	Attention: IHE standards do not provide for the possibility to edit patient data received through Dicom Worklist. By enabling this option, the patient data management will not comply anymore to these standards.
Automatic Import	When the option is enabled, today's Worklist is automatically imported.	It is suggested to enable the option.
Enable Wildcard	This option makes easier the search by Patient's name , allowing to enter even a partial text.	For example, entering "John", all patients containing "John" will be recalled and shown in the list.

4.5.2.4 MEDIA

The DICOM Media function lets you transfer the studies to USB Pen Drive (memory stick).

This function has the following options:



Image Options		Notes
Writings on Image	Image transferred together with its text (patient name, image nr., etc.) as shown on the monitor.	If not enabled, the image is sent without any writings. These will, in any case, be sent via the relevant DICOM fields.
Graphics on Image	Transfer of the image with overlay (text or measurements) added by the operator.	If not enabled, the image is sent without any graphic overlay.

Modality Options		Notes
Presentation LUT	Enables the "complete" transfer of the image, followed by the presentation LUT parameters.	Only suitable for DX images.
W/L LUT expansion	Option only active when the Presentation LUT option is not enabled. This lets you determine the level of the LUT expansion for the image sent to the server compared to that used for its presentation on the monitor. Possible values: 0 - 30% , towards both black (B) and white (W).	This function lets you include in the image parts of the histogram outside the image actually shown on the monitor.
Bits per pixel for CR/DX	The number of bits/pixels for the image being sent (CR/DX modes). Possible values: 8 - 12 - 16 bits/pixel.	
Bits per pixel for RF/XA	The number of bits/pixel for the image being sent (RF/XA modes). Possible values: 8 - 12 - 16 bits/pixel.	

If PatientID IS EMPTY	If the "Patient ID" is not available, the DICOM field can be filled according to one of these choices: - Patient name: the patient's name is entered. - Patient ID: the words "Patient ID" is entered.	
If StudyID IS EMPTY	If the "Study ID" parameter is not available, the DICOM field can be filled according to one of these choices: - Study UID: the parameter Study UID is inserted. - Study ID: the words "STUDY ID" is entered.	

Other options		Notes
Charset	Character Set used for DICOM transfer.	Select one of the available options.
Image Dir	Name of the temporary directory used to save the data during the creation of the DICOM files you want to transfer.	Fix setting D:\Media_tmp
Viewer Dir	Directory where the DICOM viewer is saved; this will be loaded on the memory device together with the images.	Fix setting D:\cd_utility
Enable the store of multiple studies	It enables the possibility to save multiple studies on the same device. Warning: <i>this operation is not compliant with DICOM standard.</i>	To activate this function, it is necessary to tick the corresponding box during saving procedure.
Anonymized Export	If enabled, it allows to export images in the study by anonymizing patient data.	If not selected, you can still enable the function during the Export phase (see Paragraph 6.6, Section 2 of the User Manual).
Export Type	Image export type. Choose between: - DICOM = in DICOM format - WEB VIEW = in WEB view format - DICOM AND WEB VIEW = both formats	
Single Image Export Format	Format of the single images to be exported. Choose between: - BMP - JPEG	
Sequence Image Export Format	Format of the sequences of images to be exported. Choose between: - AVI - MP4 - BMP - JPEG	

4.5.2.5 STORAGE COMMITMENT

The DICOM Storage Commitment function lets you receive confirmation that the images sent to the Storage server have been archived successfully.

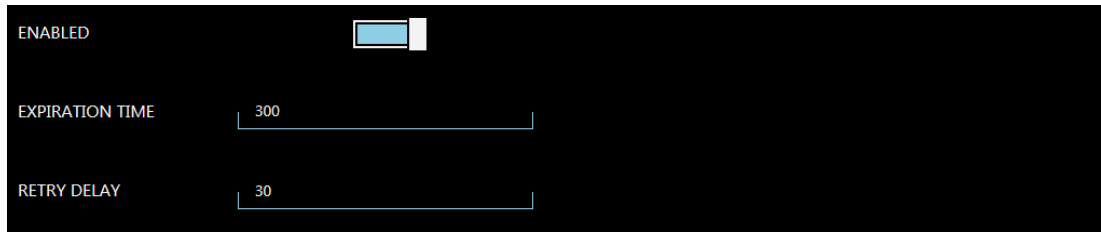

Storage Commitment Settings		Notes
Enabled	Enabling of the Storage Commitment service.	
Expiration Time	Used to set the pause (in seconds) for receipt of confirmation from the Storage Commitment server.	If no confirmation is received within this period, the STORAGE COMMITMENT function has failed.
Retry Delay	Used to set the delay (in seconds) before a new STORAGE COMMITMENT request following a failed attempt.	5 - 300 s (Default 5s)

4.5.2.6 MPPS

The DICOM MPPS server is used by the equipment to communicate progress in the performance of a study (study in progress, study completed, study archived).

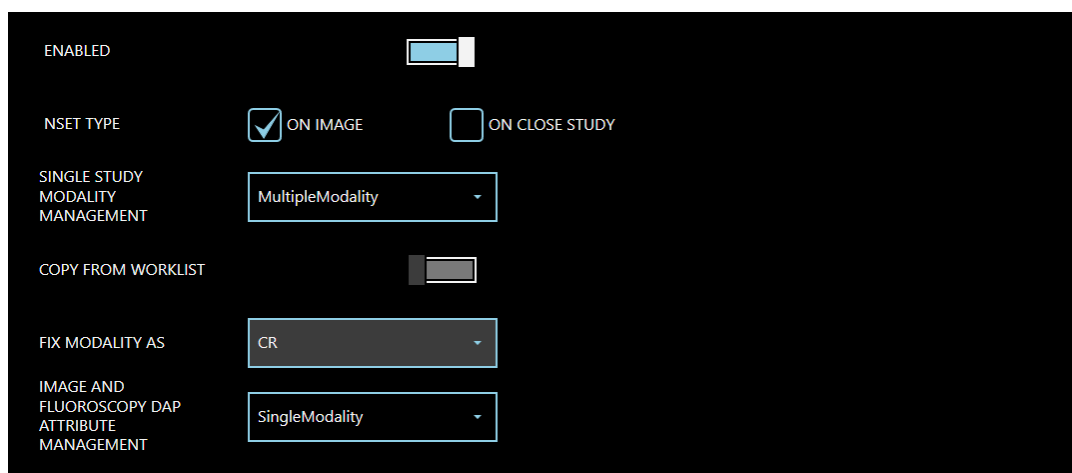

MPPS Settings		Notes
Enabled		Enabling of the MPPS service.
N-SET TYPE	ON IMAGE	Orders the creation of the MPPS message sent to the server after the first acquisition. This is then updated after each acquisition. As soon as the study is closed, the MPPS message is then flagged as "completed".
	ON CLOSE STUDY	Orders the creation of the MPPS message sent to the server after the first acquisition. As soon as the study is closed, the MPPS message is updated with all the acquisitions and flagged as "completed".
SINGLE STUDY MODALITY MANAGEMENT	Single modality	The MPPS message is sent as a single "pack" containing all the images information together (even if acquired with different modality).
	Multiple modality	A new MPPS message is sent every time the acquisition modality is changed.
COPY FROM WORKLIST		The acquisition modality attribute (CR, DX, RF, XA) is compiled with the corresponding attribute present into the Worklist. The option can be enabled only if " Single Modality " is enabled.
FIX MODALITY AS		Select a default acquisition modality attribute (CR, DX, RF, XA). The option can be enabled only if " Copy from Worklist " is disabled.
IMAGE AND FLUOROSCOPY DAP ATTRIBUTE MANAGEMENT	Single modality	The MPPS complete message contains only the DAP dose of the images grouped into that sequence. The option can be enabled only if " Multiple Modality " is enabled.
	Whole Study	Last MPPS complete message contains the total DAP dose reached. Please, refer to MPPS SCP provider on how to configure this value. A wrong configuration could lead to collect wrong accumulated dose data.

4.5.2.7 RADIATION DOSE STRUCTURE REPORT (RDSR)

The DICOM Radiation Dose Structure Report (RDSR) is used to transmit the exposure parameters and the X-ray doses for each image in a study, together with the X-ray doses for all exposures during a stud

The **Dose SR** sub-menu in the **DICOM Setup** menu lets you set the following parameters:

The screenshot shows the DICOM Setup interface with the DOSE SR sub-menu selected. The interface is organized into several sections:

- TRANSFER MODE:** Contains two toggle switches: "AUTOSTORE ON STUDY CLOSE" and "SAVE ON DICOM MEDIA".
- REFERENCE POINT:** Contains a text input field for "DISTANCE SOURCE TO RP" (set to 150) and a dropdown menu for "RP DEFINITION" (set to "15cm from Isocenter toward Source").
- RECORDING:** Contains text input fields for "RECORDING UID" (1.3.76.6.1.2.1.1.12), "RECORDING NAME" (Device 1), and "PHYSICAL LOCATION" (Sala RX1). There is also a "DOSIMETER CALIBRATION" section with a "MANAGE CALIBRATIONS" button.

TRANSFER MODE		Notes
AUTOSTORE ON STUDY CLOSE	Enables the automatic transmission of the DOSE REPORT when the study is closed.	
SAVE ON DICOM MEDIA	Enables the transfer of the DOSE REPORT to USB pen drives.	

REFERENCE POINT		Notes
DISTANCE SOURCE TO RP	Distance of the reference point used to calculate the X-ray dose and the X-ray source.	Set: 766mm
RP DEFINITION	Distance of the reference point used to calculate the X-ray dose and the FPD surface. - 15cm from Isocenter toward Source - 30cm in Front of Image Input Surface - 1 cm above Tabletop - 30cm above Tabletop - 15cm from Table Centerline - Entrance exposure to a 4.2cm breast thickness - In Detector Plane	Select: 30cm in Front of Image Input Surface

RECORDING		Notes
RECORDING UID	Identification of the recording device.	Fix setting
RECORDING NAME	Name of the recording device.	C-ARM
PHYSICAL LOCATION	Physical position of the recording device.	Set by the user.
DOSIMETER CALIBRATION	Calibration of the dose measuring device (DAP).	See image and table below.

Dosimeter Calibration

CALIBRATION HISTORY 1/1

DATE	RESPONSIBLE PARTY	PROTOCOL	CALIBRATION

FACTOR

RESPONSIBLE PARTY

UNCERTAINTY

PROTOCOL

DOSIMETER CALIBRATION		Notes
FACTOR	Calibration factor used for the device.	Multiplication factor to correct the value measured by DAP in order to get the right value. Set 1 if the value provided does not require any correction.
RESPONSIBLE PARTY	Body responsible for dosimeter calibration.	
UNCERTAINTY	Inaccuracy of the device.	Percentage value between $\pm 0 - 100\%$
PROTOCOL	Description of the calibration protocol.	

4.5.2.8 QUERY / RETRIEVE

The DICOM QUERY / RETRIEVE functions let you view digital images generated by other image diagnostics programs on the equipment (e.g. CT, MR, ECHO, etc.).

OPTIONS	
SERVICE AE TITLE	AET_QR
SERVICE IP PORT	105
SEARCH FROM PATIENT ROOT	<input checked="" type="checkbox"/>
ENABLE WILDCARD	<input type="checkbox"/>
CONFIGURATION	
RETRIEVE DIR	D:\dicom_retrieve_data
VIEWER PATH	C:\Program Files (x86)\ETIAM\Open LiteBox\DcmLtBox.exe

List Options		Notes
Service AE title	AE Title of the remote device providing the Query / Retrieve service.	
Service IP Port	TCP Port used by the remote device providing the Query / Retrieve service.	
Search from Patient Root	If a problem with the recovery of the images occurs during installation, it may be due to a PACS setting. The activation of this option increases the compatibility and allows to solve the problem.	
Enable Wildcard	This option makes easier the search by Patient's name , allowing to enter even a partial text.	<i>For example, entering "John", all patients containing "John" will be recalled and shown in the list.</i>



Configuration		Notes
Retrieve Dir	Position on the HD of the directory that will hold the exams received from the remote Query / Retrieve device.	
Viewer Path	Position on the HD of the DICOM Viewer that lets you view the exams received from the remote Query / Retrieve device.	

4.5.3 DICOM DEVICES

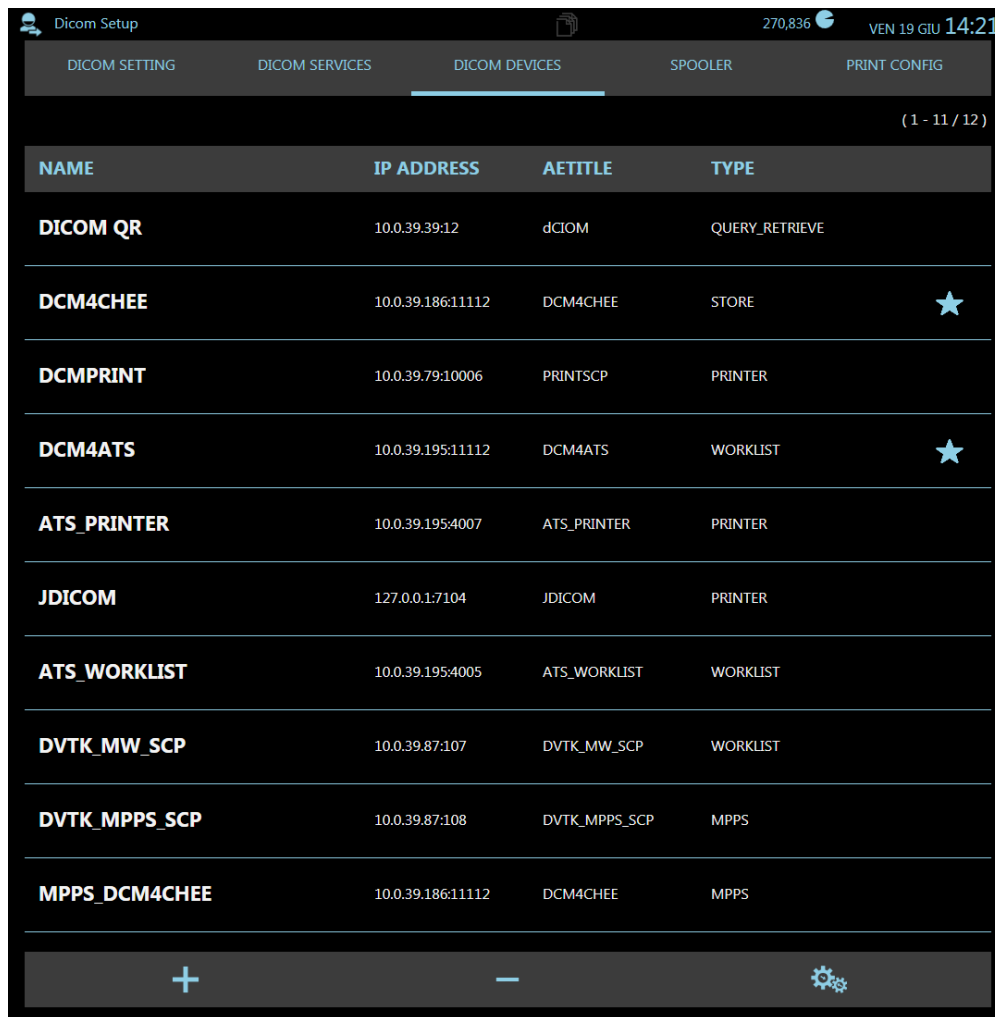
The **DICOM Devices** setup menu lets you manage the settings of all the remote DICOM devices.



It is possible:

- Add new devices using the command  ;
- Delete devices, using the command  ;
- Set the options for each device (see list below);
- **Check** the connection with the selected remote device (Verify), using the command  .

Note: In DICOM devices list, all the **devices set as default** are marked with a star.



The following parameters can be set for all the remote devices:



Device configuration		Notes
Name	Conventional name of the remote DICOM device within the hospital network.	Defined by the network administrator.
AE Title	AE Title of the remote DICOM device.	Defined by the network administrator.
IP Address	IP address of the remote DICOM device within the hospital network.	Defined by the network administrator.
IP Port	TCP port of the remote DICOM device.	Defined by the network administrator.
Type	Type of DICOM service provided by the remote DICOM device.	Select one of the options.
Charset	Character set used to send DICOM files.	This parameter must match that set in Windows and the keyboard properties.

Depending on the service being provided, the remote device may be enabled for one of these functions:

- **Store:** image archiving service.
- **Worklist:** service that gathers the studies to be performed (WORKLIST SCP).
- **Printer:** image printing service (PRINTER SCP).
- **MPPS:** study status data and updating service (study in progress, study completed, study archived, etc.).
- **Storage Commitment:** service that confirms (via the PACS) that the received images have been archived successfully.
- **Dose SR:** service that gathers information on the X-ray dose.
- **Query/Retrieve:** service that requests archived studies from other imaging systems (Q/R SCP).
- **Store Multiple:** service that lets you archive studies on several devices.

➤ **STORE DEVICES**

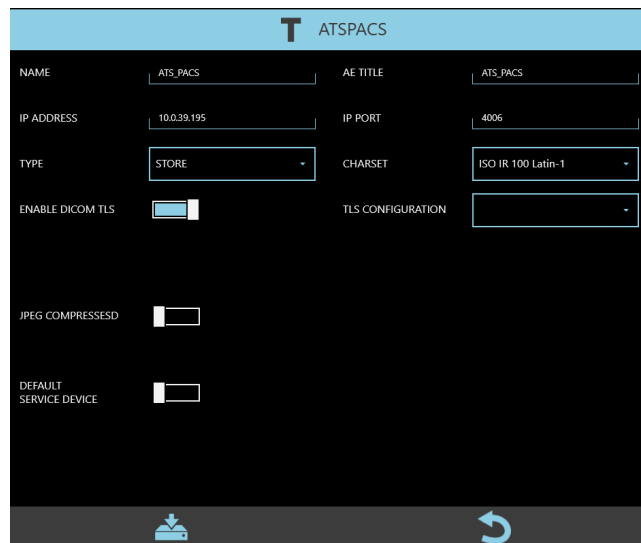

In addition to the general parameters, the following parameters also have to be set for STORE devices:

Device configuration		Notes
Enable DICOM TLS	Option to be selected if you want to use a cryptographic protocol.	
TLS Configuration	Drop-down menu for selecting the folder that contains the details of the encryption system (DICOM TLS) to be combined with the Store device.	See Paragraph 4.5.3.1 below for more details.
JPEG uncompressed	Select this option if the receiving server cannot handle compressed JPEG images (XA and RF modes).	
Default Service device	Used to select the device to be used as the default unit for the Store service.	The selected device will automatically receive the images as soon as the study is closed (Auto Store function).

➤ **WORKLIST DEVICES**

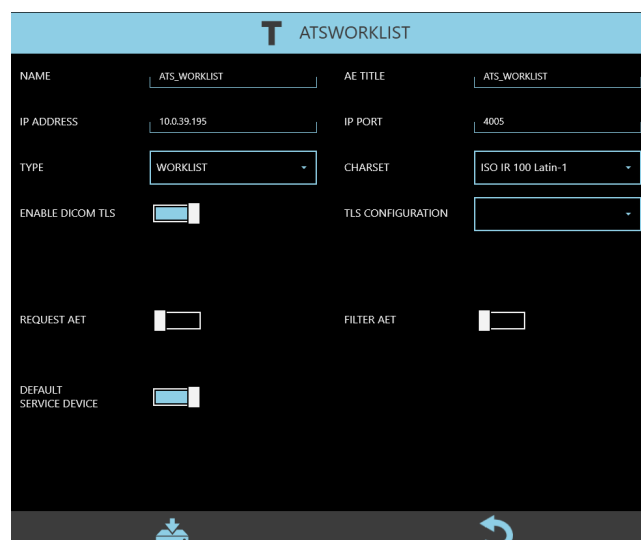

In addition to the general parameters, the following parameters also have to be set for WORKLIST devices:

Device configuration		Notes
Enable DICOM TLS	Option to be selected if you want to use a cryptographic protocol.	
TLS Configuration	Drop-down menu for selecting the folder that contains the details of the encryption system (DICOM TLS) to be combined with the Worklist device.	See Paragraph 4.5.3.1 below for more details.
Request AET	If enabled, the AE Title (AET) of the equipment is added to the Worklist request sent to the remote device.	Selection is recommended.
Filter AET	If enabled, the AET of the equipment is used as a filter for the Worklist received from the remote device.	Selection is recommended. Only those studies containing the AET set are displayed. (See Paragraph 4.5.1: <i>Dicom Settings</i>)
Default Service device	Current device can be used as the default Worklist device.	Used if there are more than one remote Worklist devices.

➤ **QUERY/RETRIEVE DEVICES**

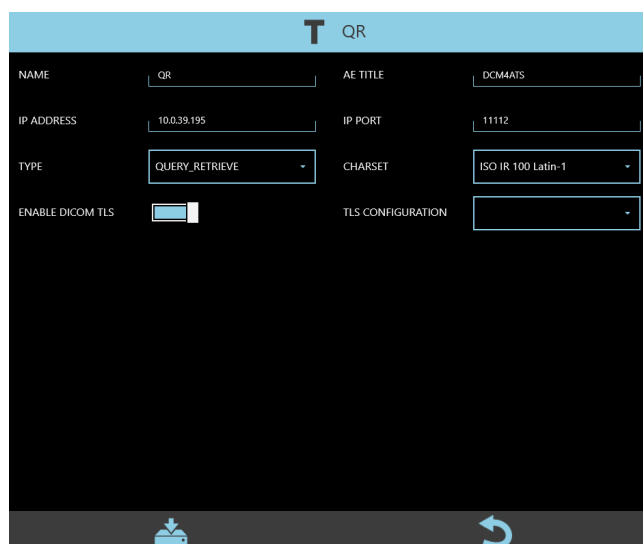

In addition to the general parameters, the following parameters also have to be set for QUERY/RETRIEVE devices:

Device configuration		Notes
Enable DICOM TLS	Option to be selected if you want to use a cryptographic protocol.	
TLS Configuration	Drop-down menu for selecting the folder that contains the details of the encryption system (DICOM TLS) to be combined with the Query/Retrieve device.	See Paragraph 4.5.3.1 below for more details.

➤ **MPPS DEVICES**

In addition to the general parameters, the following parameters also must be set for MPPS devices:

Device configuration		Notes
Enable DICOM TLS	Option to be selected if you want to use a cryptographic protocol.	
TLS Configuration	Drop-down menu for selecting the folder that contains the details of the encryption system (DICOM TLS) to be combined with the MPPS device.	See Paragraph 4.5.3.1 below for more details.
Associated device	Worklist server to be used for the MPPS service.	The list contains all the set Worklist servers previously set.

➤ **STORAGE COMMITMENT DEVICES**

In addition to the general parameters, the following parameters also must be set for STORAGE COMMITMENT devices:

Device configuration		Notes
Enable DICOM TLS	Option to be selected if you want to use a cryptographic protocol.	
TLS Configuration	Drop-down menu for selecting the folder that contains the details of the encryption system (DICOM TLS) to be combined with the Storage Commitment device.	See Paragraph 4.5.3.1 below for more details.
Associated device	Store server to be used for the Storage Commitment service.	The list contains all the set Store servers.

➤ **RDSR DEVICES**

In addition to the general parameters, the following parameters also must be set for RDSR devices:

Device configuration		Notes
Default Service device	Used to select the device to be used as the default unit for the RDSR service.	if selected, it will automatically receive the RDSR reports about a study.

➤ **MULTIPLE STORE DEVICES**

The remote MULTIPLE STORE device is a virtual device that manages the transfer of images to be archived to several Store servers at the same time. Up to 3 Store servers can be selected to create this virtual device.

Configuration		Notes
Associated Store device	Store servers to be used for the Multiple Store service.	The list contains all the set Store servers.

4.5.3.1 DICOM TLS

The DICOM TLS cryptographic protocol provides a secure communication between client and server. To create a DICOM TLS to be coupled with a DICOM device, the **ISIX Dicom TL Configuration Manager** application must be used.

Note: to run the application it is necessary to log in as Windows Administrator (see Paragraph 5.2, Part 2).

- Run the application and enter the access password: **breatheme**
- The following window opens:

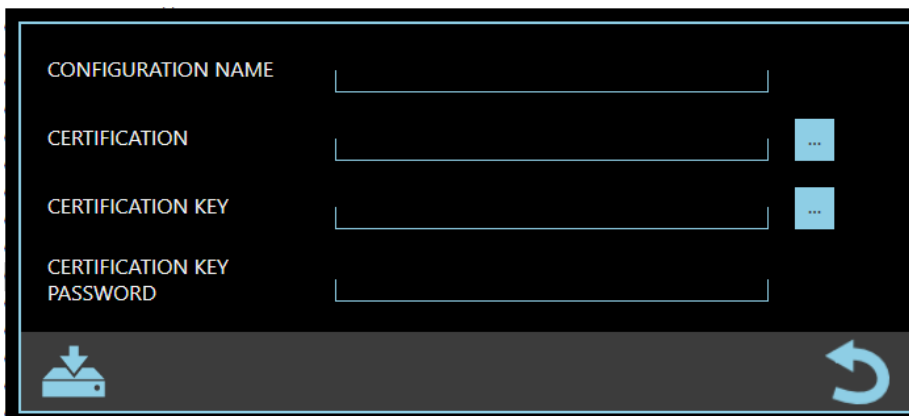

- **Configuration Name:** enter the name of the folder to be associated with the DICOM device (see paragraph 4.5.3 above)
- **Certification*:** select the file containing the certificate
- **Certification key*:** select the file containing the certification key
- **Certification key Password*:** enter the password to be linked with the certification key

***Note:** the files and password must be provided by the person in charge of the structure in which the equipment is installed.

- Save the set parameters by pressing the button:



4.5.4 SPOOLER

This menu contains the DICOM Spooler settings.

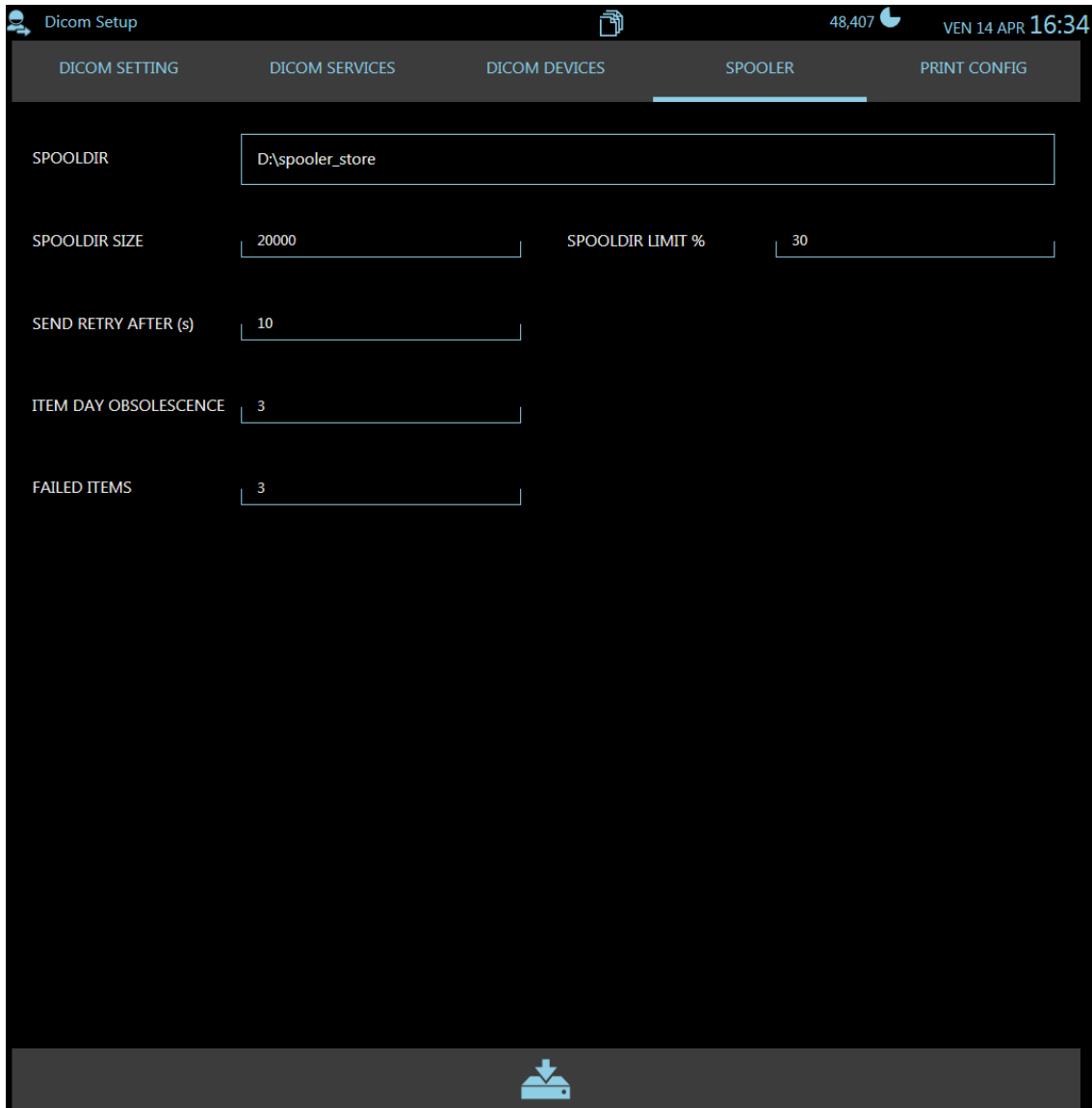

Spooler Settings		Notes
Spooldir	Name of the directory where the DICOM files to be sent are temporarily saved.	
Spooldir size	Size of the Spooldir directory (MByte).	
Spooldir limit %	Filling limit of Spooldir directory (in percentage); once reached, a warning is generated indicating that the directory is full.	
Send retry after (s)	Pause (in seconds) before the next transmission attempt.	The DICOM file is flagged as "failed" after 3 unsuccessful attempts.
Item day of obsolescence	Number of days that a DICOM item remains in the Spooldir .	An alarm is generated when this limit is reached.
Failed Items	Max number of DICOM files flagged as "failed" in the Spooldir .	An alarm is generated when this limit is reached.

4.5.5 PRINT CONFIGURATION

The selected images in the study (selected using the "PINNING" function) are automatically sent to the chosen DICOM printer (see procedure below).
Up to 4 print configurations are possible. These will be listed as options for the operator.

Configuration includes:

- Choice of printer
- General printing settings
- Processing of images
- Film size
- Film orientation (portrait / landscape)
- Print format (lines and columns)

The PRINT CONFIG menu lets you set these 4 print configurations:

General configuration		Notes
Name	Name given to the configuration	This name will be used by the equipment to identify the specific print configuration.
Printers	List of DICOM printers from which to choose one to configure.	The list contains all the previously defined Print servers.

The printing parameters are:

Options		Possible values provided by standard DICOM* (See note *)							
Priority	Print priority for the printer.	HIGH MED (default) LOW							
Copies	Number of copies to be printed.	1 (default)							
Medium Type	Type of print medium.	PAPER CLEAR FILM BLUE FILM							
Film Destination	Film Destination	MAGAZINE PROCESSOR BIN_1 BIN_2 BIN_10							
Magnification Type	Type of interpolation used by the printer to adapt the image to the envisaged size of the film.	REPLICATE BILINEAR CUBIC NONE							
Smoothing type	Type of interpolation only valid for the CUBIC Magnification Type .	These values must suit the Conformance Statement accompanying the printer.							
Border Density	Density of the area around and between the images.	BLACK WHITE							
		Number that specifies the required density in 100ths of OD (150 corresponds to 1.5 OD).							
Empty Image Density	Density of the frame on the film in the absence of an image.	BLACK WHITE							
		Number that specifies the required density in 100ths of OD (150 corresponds to 1.5 OD).							
Orientation	Film orientation	PORTRAIT = film arranged vertically LANDSCAPE = film arranged horizontally							
Film Size	Size of the film.	8INX10IN 8_5INX11IN 10INX12IN 10INX14IN 11INX14IN 11INX17IN 14INX14IN 14INX17IN 24CMX24CM 24CMX30CM A4 A3 Note: 10INX14IN corresponds to 25.7CMX36.4CM A4 corresponds to 210x297 mm. A3 corresponds to 297x420 mm.							
Bits per Pixel	Bits per Pixel	8, 12, 16							
Annotation	Annotations on the image.	ON = annotations enabled. OFF = annotations disabled.							
Format	Type of image format	The film contains rectangles, all of the same size, with R rows and C columns.							
	STANDARD	Set the required values as follows: <table border="1" style="margin-left: auto; margin-right: auto;"> <tr> <td>Field1</td> <td>Field2</td> <td>Field3</td> <td>Field4</td> </tr> <tr> <td>C</td> <td>R</td> <td></td> <td></td> </tr> </table>	Field1	Field2	Field3	Field4	C	R	
Field1	Field2	Field3	Field4						
C	R								

Options		Possible values provided by standard DICOM* (See note *)								
	ROW	<p>The film contains rows with equal rectangles and with R1 images in the first row, R2 images in the second and R3 in the third, etc.</p> <p>If used, set the required values as follows:</p> <table border="1"> <tr> <td>Field1</td> <td>Field2</td> <td>Field3</td> <td>Field4</td> </tr> <tr> <td>R1</td> <td>R2</td> <td>R3</td> <td>R4</td> </tr> </table>	Field1	Field2	Field3	Field4	R1	R2	R3	R4
Field1	Field2	Field3	Field4							
R1	R2	R3	R4							
	COL	<p>The film contains columns with equal rectangles and with C1 images in the first row, C2 images in the second and C3 in the third, etc.</p> <p>If used, set the required values as follows:</p> <table border="1"> <tr> <td>Field1</td> <td>Field2</td> <td>Field3</td> <td>Field4</td> </tr> <tr> <td>C1</td> <td>C2</td> <td>C3</td> <td>C4</td> </tr> </table>	Field1	Field2	Field3	Field4	C1	C2	C3	C4
Field1	Field2	Field3	Field4							
C1	C2	C3	C4							

***Note:** Values depend on the printer model used. Therefore, refer to printer Conformance Statement during setup procedure.

4.5.5.1 PRINT ANNOTATION SETUP

You can set the layout of the writings to be added to the print film.

This is done using the **PRINT ANNOTATION** menu, which lets you establish the text to be added, its position and size.

This text box is added to each image, regardless of the layout and printer selected.

The text is normally split into the following components:

- o **Header/ footer:** typically, with the common study data (hospital name, patient name, etc.).
- o **Image overlay:** typically, with the image data (image n°, date/time acquired, etc.).

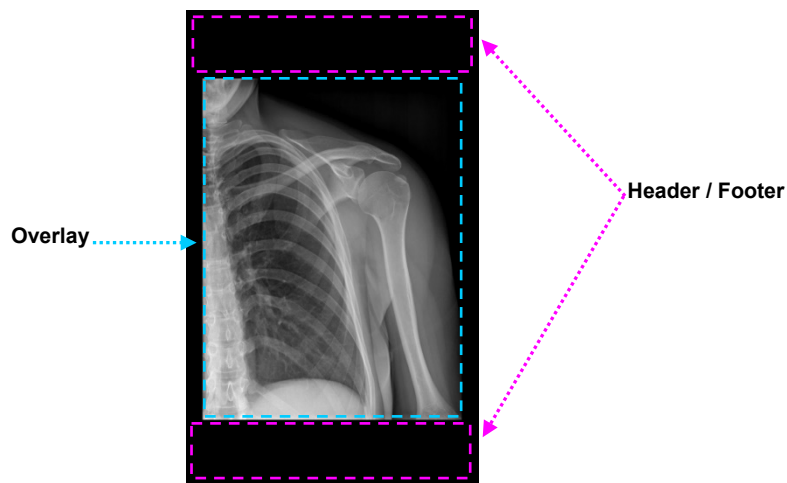

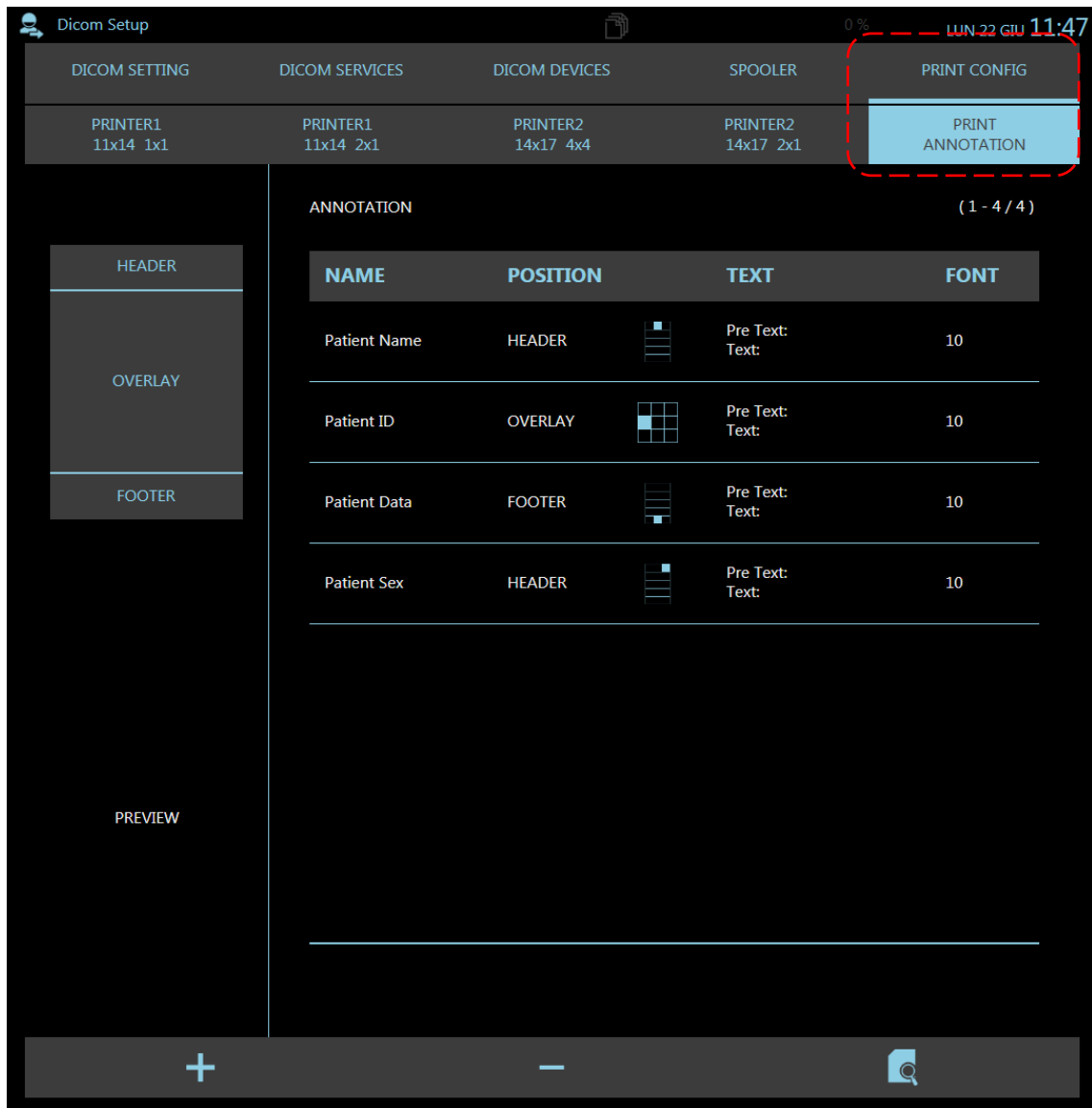

Access the **Print annotation** sub-menu from the PRINT CONFIG menu:



It is possible:

- Add a new annotation, using the command  ;

- Delete an annotation in the list, with the command  ;

- View an annotation in the list, using the selecting it and then enlarge its preview with the command 

- Use the **Add annotation** command to add a new box:

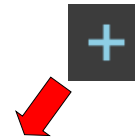

🖨️ New Print Annotation

POSITION	<input type="text" value="HEADER"/>	ELEMENT	<input type="text" value="Free text"/>
PRE TEXT	<input type="text"/>	TEXT	<input type="text"/>
FONT SIZE	<input type="button" value="+"/> <input style="width: 40px; text-align: center;" type="text" value="10"/> <input type="button" value="-"/>		

Position inside HEADER

	LEFT	CENTER	RIGHT
ROW 1			
ROW 2			
ROW 3			
ROW 4			
ROW 5			

📄
↻

- Use the POSITION field to select the position of the new annotation. Options:
 - HEADER
 - OVERLAY
 - FOOTER

POSITION

The position grids for the HEADER and FOOTER fields have:

- 5 rows (**Row 1, 2, 3, 4, 5**)
- 3 columns (**Left, Center, Right**)

Position inside HEADER

	LEFT	CENTER	RIGHT
ROW 1			
ROW 2			
ROW 3			
ROW 4			
ROW 5			

While the position grid for the OVERLAY field has:

- 3 rows (**Top, Middle, Bottom**)
- 3 columns (**Left, Center, Right**)

Position inside OVERLAY

	LEFT	CENTER	RIGHT
TOP			
MIDDLE			
BOTTOM			

- Select the box in the grid where you want to add the new annotation.

- Select one of the field options for the ELEMENT field:

ELEMENT Free text

- Free text
- Patient Name
- Patient ID
- Patient Birthday
- Patient Sex
- Accession Number
- Study Date
- Physician
- Study Description
- Hospital Info
- Print Date
- Image data time
- Serie / Image Number

- Add extra text in the PRE-TEXT / TEXT fields.

PRE TEXT TEXT

- Set the size of the **Font** (text size, in mm), using the + and - commands.

FONT SIZE + 10 -

- In the case of OVERLAY, you can also set the position of the annotation within the grid by using the 2 offset values:

X OFFSET 0 Y OFFSET 0

- Once you have set the new annotation, save it using the command . The new annotation is now added to the list of saved annotations.

- Repeat this procedure for each new annotation you wish to add.

- After selecting an annotation in the list, you can get a preview in the space shown:

PRINTER1
11x14 1x1
PRINTER1
11x14 2x1
PRINTER2
14x17 4x4
PRINTER2
14x17 2x1
PRINT ANNOTATION

HEADER

OVERLAY

FOOTER

PREVIEW

ANNOTATION (1 - 4/4)

NAME	POSITION	TEXT	FONT
Patient Name	HEADER	Pre Text: Text:	10
Patient ID	OVERLAY	Pre Text: Text:	10
Patient Data	FOOTER	Pre Text: Text:	10
Patient Sex	HEADER	Pre Text: Text:	10

4.6 DRC GROUP SETUP

The EM equipment can be programmed for up to 6 exam types. Once the operator selects an exam, the parameters set for that type of exam are automatically loaded.

Each exam can use one of three **DRC processes (dynamic range compression)** from within a single **DRC GROUP**.

These three processes are programmed during installation to suit the type of exam.

You can use the **DRC GROUP SETUP** menu to set “n” groups of 3 processes from among those that appear in a pre-set list.

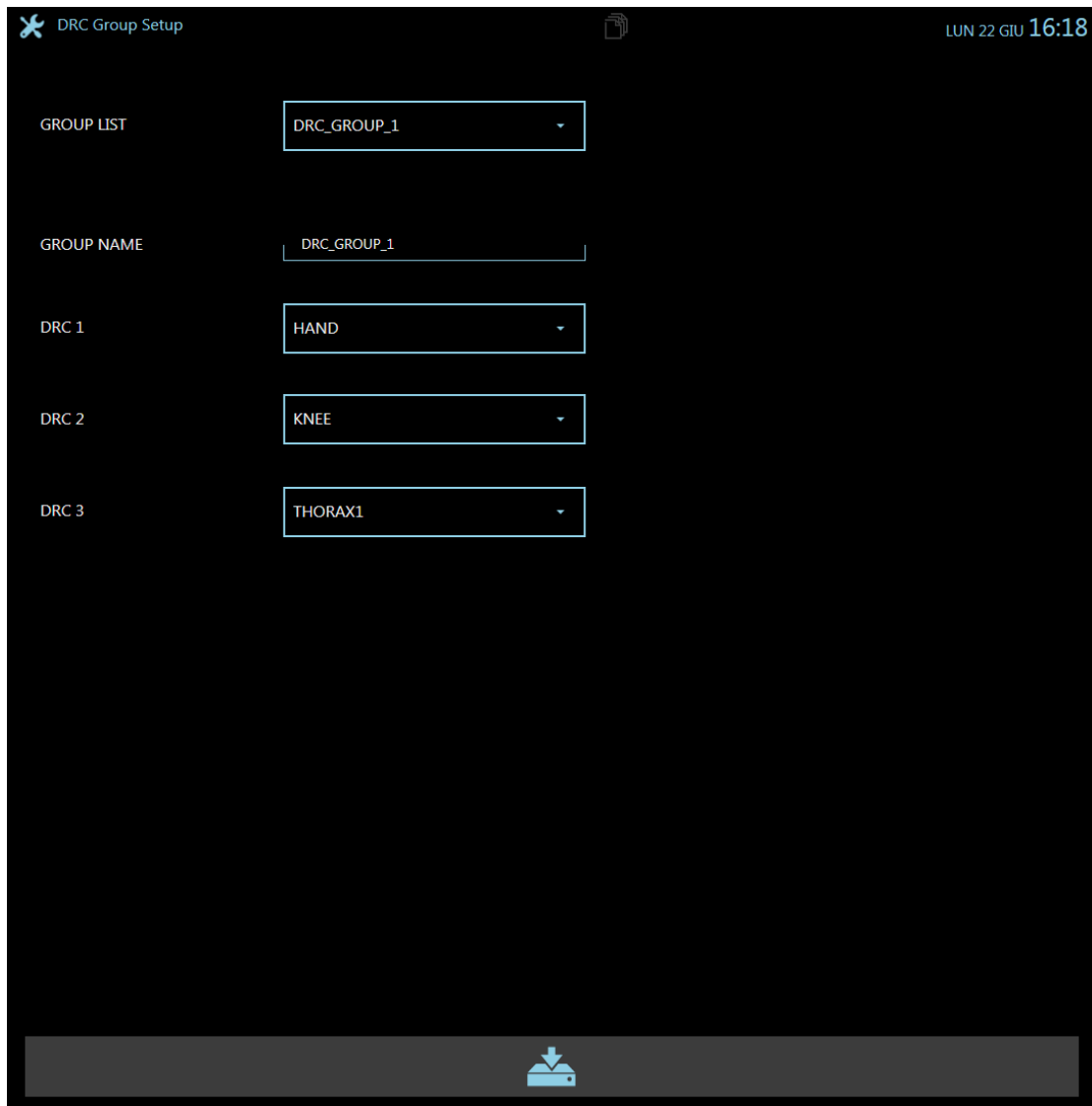

- Select one of the groups in the GROUP LIST box.
- You can change its name in the GROUP NAME box.
- Select the 3 processes to be associated with the selected group (DRC1, DRC2 and DRC3).



- Save the settings with the command  .

4.7 DRC EDITOR

This menu lets you customize the name of the available **DRC processes** to make them clearer for the operator during the exam.

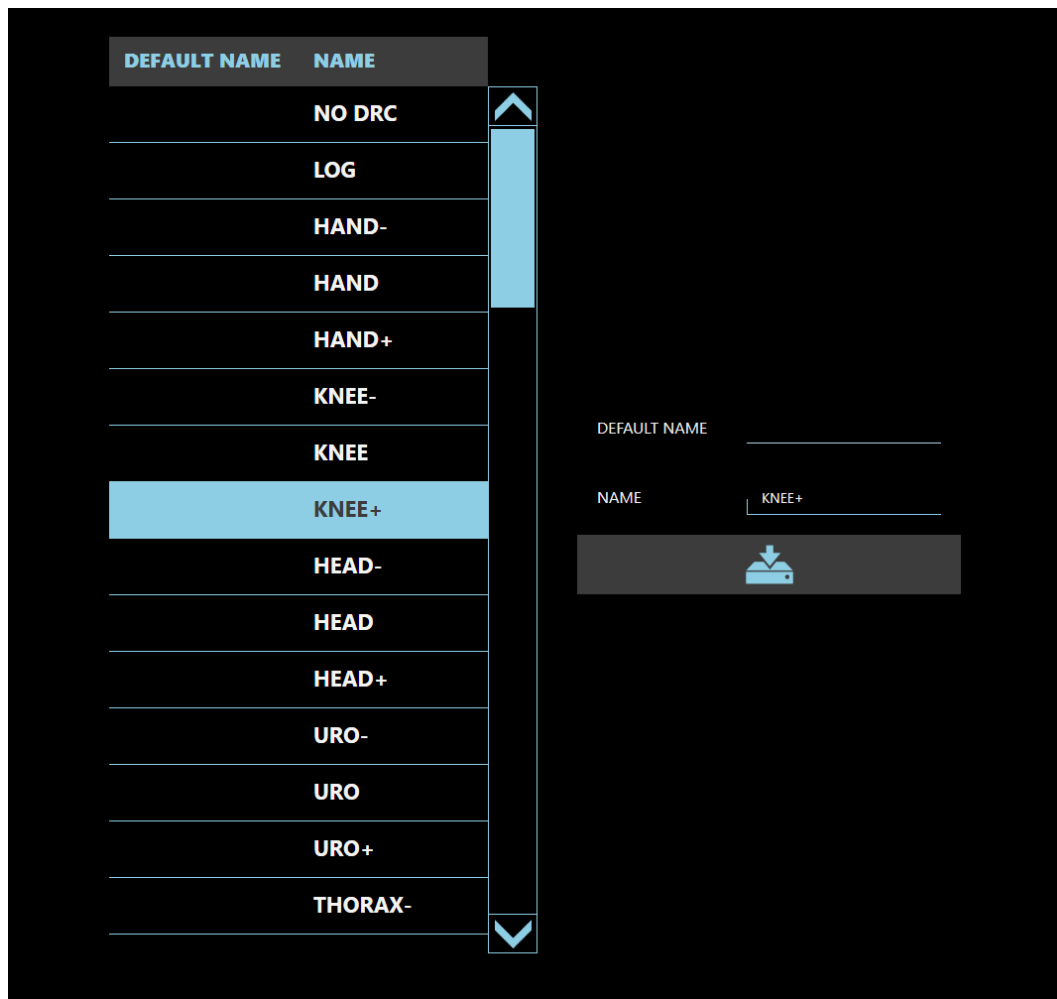

- Select the process name that you wish to modify.
- Enter the required name and save. The selected name will be updated in the list.

4.8 USER ACCOUNT SETUP

The **User Account Setup** menu (accessed by **Administrator** and **Advanced** users only) lets you manage the creation, enabling/disabling and deletion of system users.

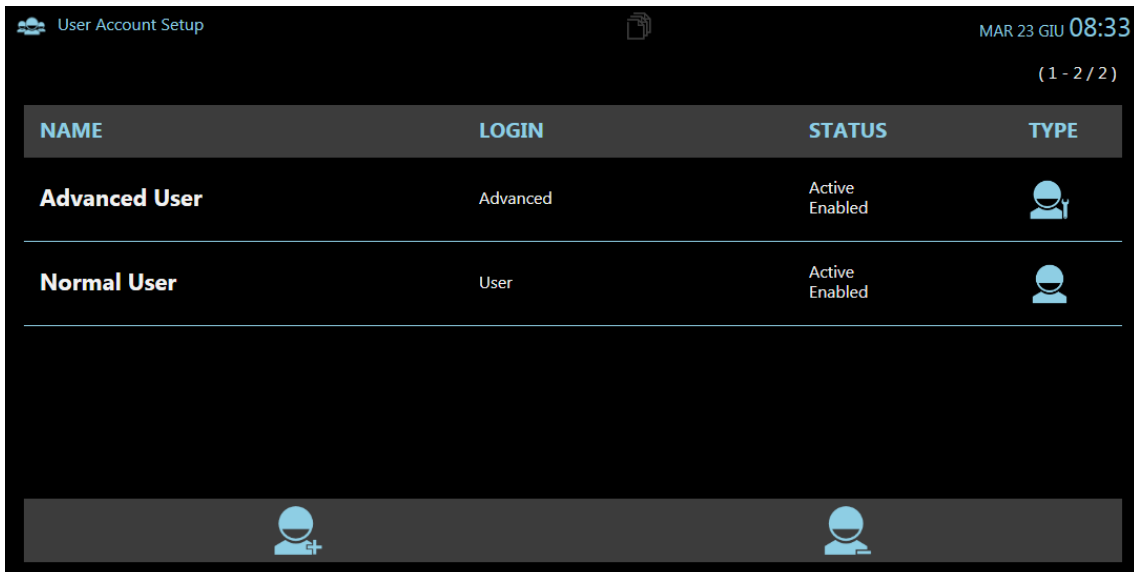

There are three user levels:

- Administrator (user pre-set in the factory)
- Advanced (set during installation)
- User

The privileges for each user type are:

- **Administrator:** full access to the EM equipment
- **Advanced:** routine operations and access to the following SETUP pages:
 - *General Settings* setup,
 - *Exam* setup,
 - *User Account* setup,
 - *Fixed String* setup.

Note: some of the parameters should not be changeable by the **Advanced** user.

- **User:** routine operations only.

Each user has a unique password.

The system is meant to have only one **Administrator** user, with a unique password (pre-set and that never expires).

- Select the command  to open the user configuration page:

- Here you can set:
 - **Login:** name used to identify the user accessing the equipment (username);
 - **Name:** typically, the user's full first name and surname;
 - **Password and Repeat Password:** password to be entered in order to access the equipment (at least 8 characters);
 - Option **Active:** the created user will be automatically disabled if he does not access the application within six months of his last login;
 - Option **Enabled:** the new user is enabled and his username will be shown in the Login screen;
 - Level: **Normal / Advanced:** (N.B.: a new Administrator cannot be created).
 - **Read Badge** function: This function allows to associate to each user a magnetic personal badge, useful for speeding up the Login procedure. To enable this function, just place the badge near the reader and press the **Read Badge** key. A message appears to confirm the badge has been correctly linked to its user.

- Press the command  to complete the user entry and save the data.

Each password is valid for 90 days, after which time the user must enter a new one. 15 days before a password expires, a warning message appears whenever the user logs in, indicating that the password will expire shortly.

If a user does not use the equipment for 6 months, the corresponding user account is automatically disabled and will not be displayed in the LOGIN list.

4.9 FIXED STRING SETUP

In the menu **Fixed String**, which can be accessed by the **Administrator** and **Advanced**, users it is possible to preset a series of often used texts ("fixed strings") and which can be easily retrieved by the operator during the post-processing operations so as to place them on the acquired image.

To create and update this list of strings, use the **Fixed Strings Setup menu**:



Any number of strings can be added (max length 20 characters).
The commands are:



to add a new string (after all existing ones),



to delete the selected string from the list,



to shift the selected string up/down within the list.

- Select the **New String** command to open the user configuration page:

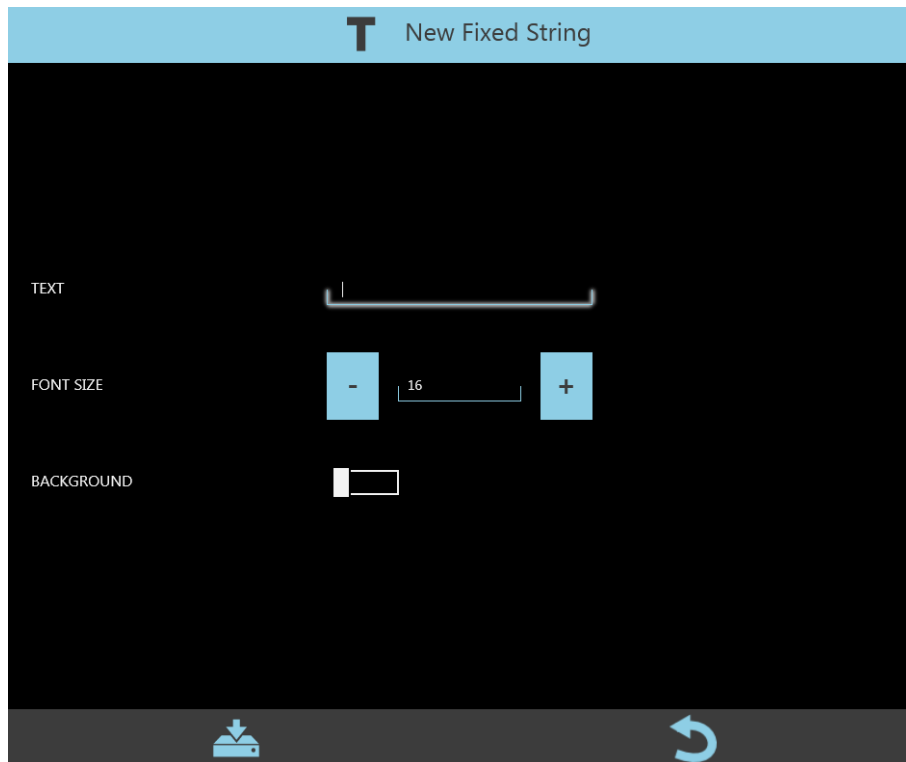

- Here you can set:
 - **Text:** contents of the string (max 20 characters);
 - **Font Size:** size of the string;
 - **Background:** a black box is added as a background for the string.

- Press the command  to complete the creation of the new string and add it to the list of existing strings.

4.10 SECURITY SETUP

The **Security Setup** menu (accessed by **Administrator**, only) lets you manage some additional security features about automatic logoff and password effectiveness.

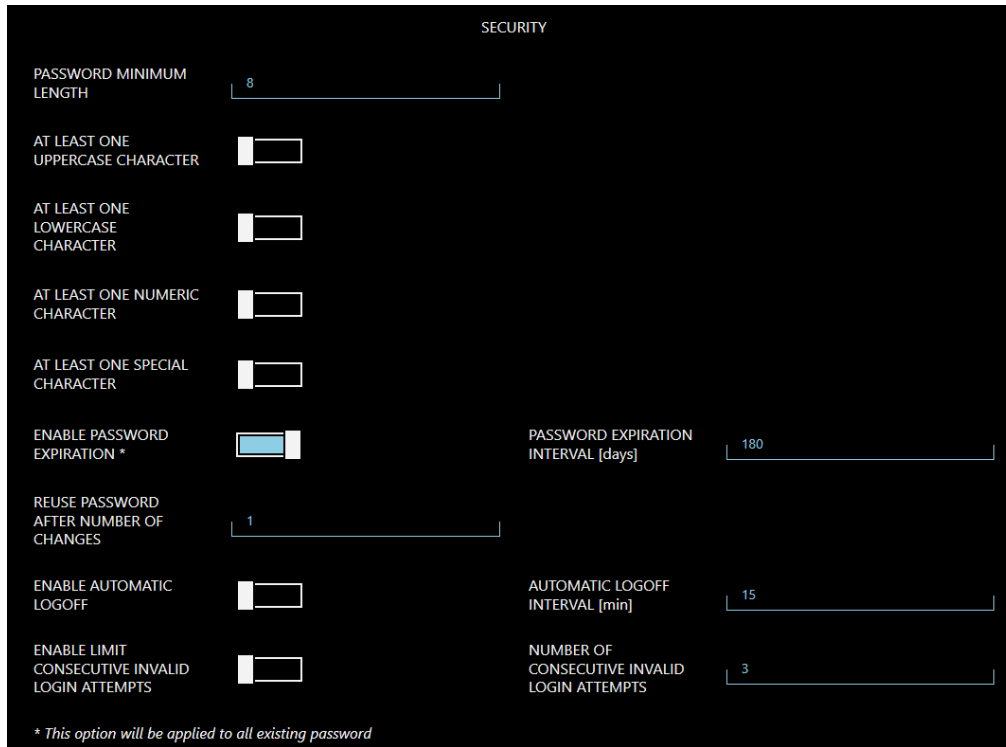

Option	Meaning	Settings	Notes
PASSWORD MINIMUM LENGTH	Minimum number of characters of the password.	4-30 characters	
AT LEAST ONE UPPERCASE CHARACTER	Passwords must contain at least one uppercase character.		
AT LEAST ONE LOWERCASE CHARACTER	Passwords must contain at least one lowercase character.		
AT LEAST ONE NUMERIC CHARACTER	Passwords must contain at least one numeric character.		
AT LEAST ONE SPECIAL CHARACTER	Passwords must contain at least one special character.		
ENABLE PASSWORD EXPIRATION	The password does not have an expiration date.		
PASSWORD EXPIRATION INTERVAL (days)	The password expires after the number of days set.	1-3650 days	
REUSE PASSWORD AFTER NUMBER OF CHANGES	An old password can be reused after the number of changes set.	1-10 times	
ENABLE AUTOMATIC LOG OFF	The system automatically returns to the login page after an inactivity interval.		
AUTOMATIC LOG OFF INTERVAL [min]	The system automatically logs off the user after the interval set.	1-60 min	
ENABLE LIMIT CONSECUTIVE INVALID LOGIN ATTEMPTS	The system blocks the possibility to log in after the number of wrong attempts set.		After 5 minutes, it will be possible to try to log in again.
NUMBER OF CONSECUTIVE INVALID LOGIN ATTEMPTS	Number of wrong attempts after which the system temporarily blocks the access.	3-15 times	

5.1 MONITOR CONFIGURATION

5.1.1 RESETTING THE MAIN MONITOR CONFIGURATION

The video processor has the following standard monitor configuration:

- **Resolution: 2560 x 1440 pixel (QHD)**
- **Orientation: Landscape**

If the PC loses its configuration, you can reset it as follows:

- Leave the **SYSTEMA DRF-S** application. (To do this, you need to log in as a *Windows Administrator*, see next paragraph).
- Touch START on the Windows tool bar and then select: **Settings > System > Display**.
- Adjust the settings as shown in the figure below:

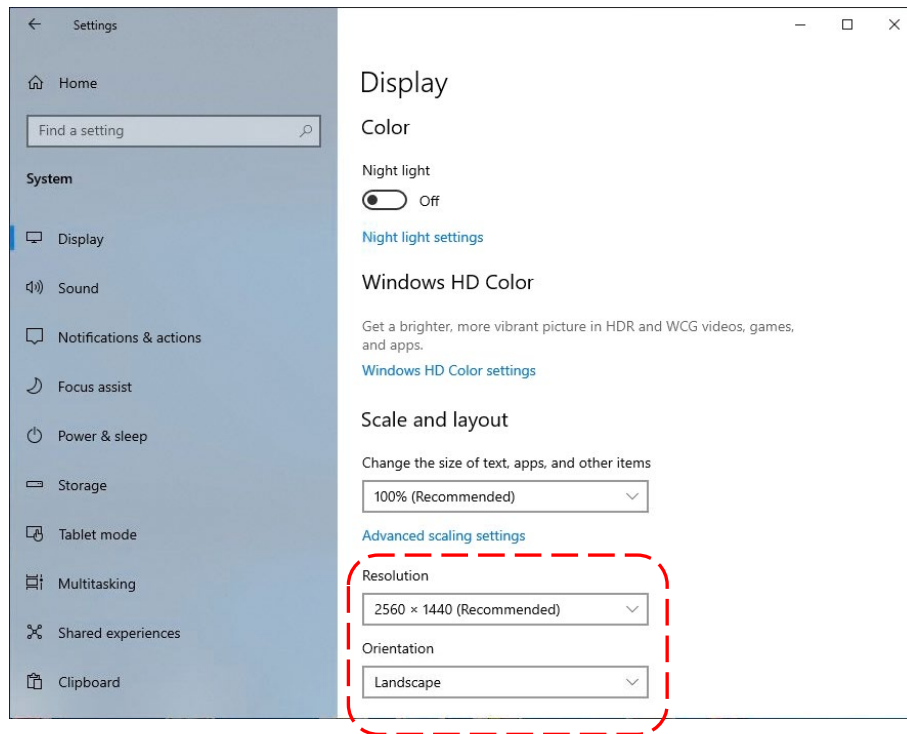

5.1.2 AUXILIARY MONITOR CONFIGURATION

The equipment has an **HDMI auxiliary socket** that allows to show on the auxiliary monitor the images present the main monitor (see Section 6.12, Part 2 of the User Manual). It is possible to decide which images you want to display on this monitor using the **ISIX Internal Setup** application, present on the desktop.



Note: To launch the application it is necessary to log in as a **Windows Administrator** (see next section).

- Launch the application and enter the login password: **breatheme**.

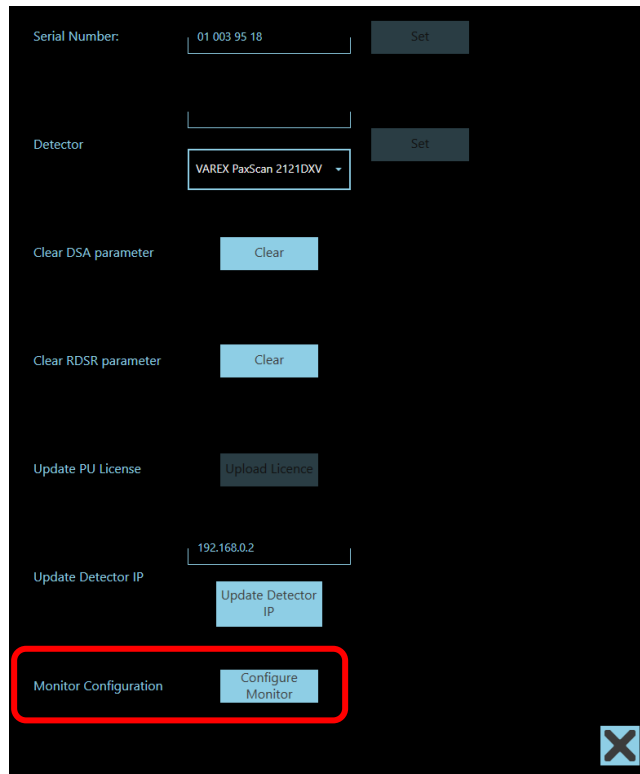

- Select the function **Configure Monitor**, the following window is opened:



Attention: DO NOT change the configuration of the main monitor (**Primary**).

- Now, set the output of the auxiliary video monitor (**output X**, that is different from the main monitor output) on the line corresponding to the desired image (Live, Memory or both).

5.1.3 TOUCH SCREEN CALIBRATION

The equipment is supplied with the monitors already configured and calibrated.

If you need to recalibrate the touch screen monitor, follow these instructions:

- Access the system as **Windows Administrator** (see the next Paragraph 5.2).
- Touch START on the Windows tool bar and then select: **Control Panel > Tablet PC Settings**.
- In the window that opens, press the **Calibrate** key:

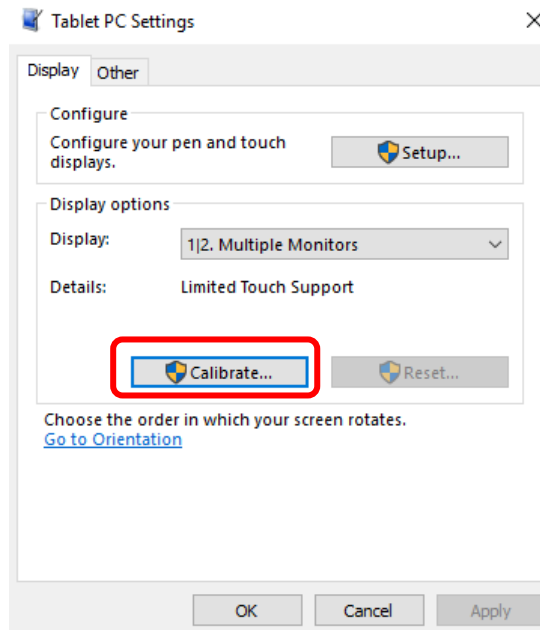

- Press with your finger on the **viewfinder** that appears in a corner of the monitor; repeat for the other corners.
- Select the **Yes** command to confirm and complete the calibration procedure.

Note: the same procedure can be used to calibrate the touch screen of the **Control Panel**.

5.2 WINDOWS ADMINISTRATOR LOG-IN

To set up the Windows operating system (or other applications on the PC) you need to log onto the PC as "Administrator".

To log in as **Windows ADMINISTRATOR**:

- Log in into the equipment application as **Administrator**.
- From the study list, click on the **Shutdown** symbol:



- In the window, select the command **Go to Windows Logon**:

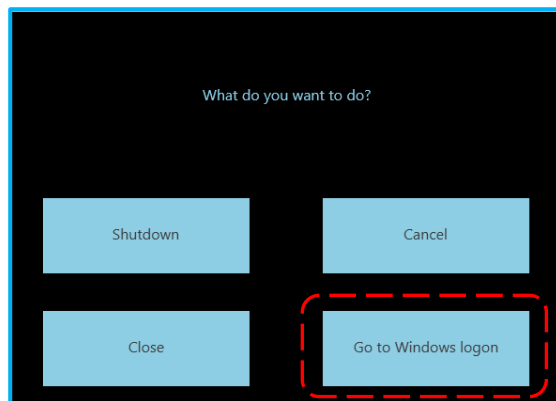

- The **SystemA DRF-S** application is now closed and Windows authentication screen is opened: In the options box, select the user: **admin2**

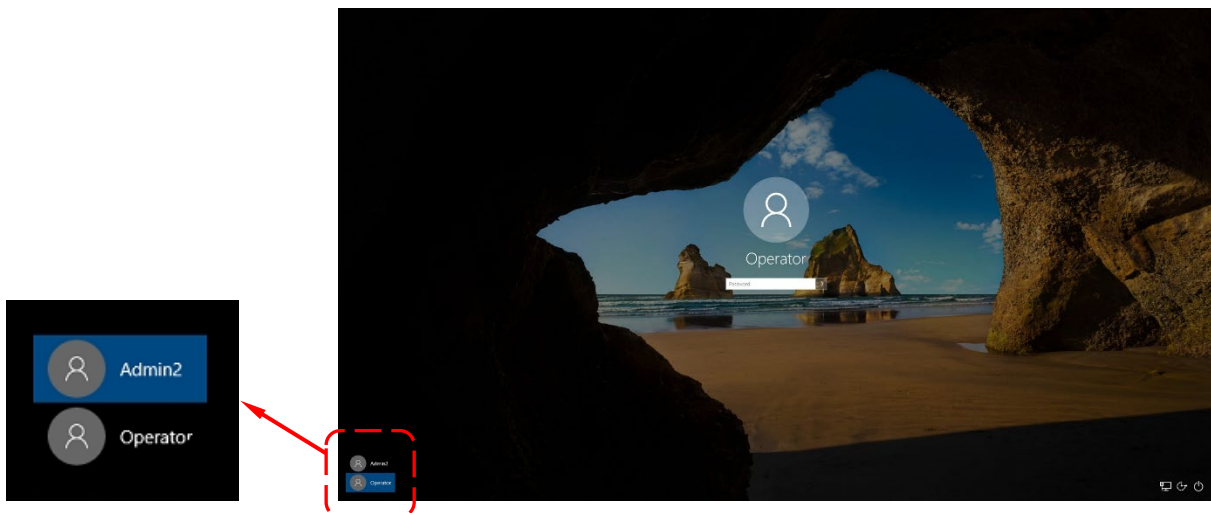

- Enter the password: **24060** and press the command 

Note: to return to the normal operator mode, repeat the procedure and select:

- user: **operator**
- password: **operator**

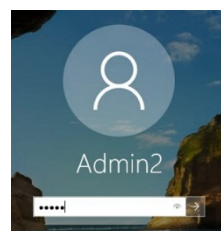

5.3 ETHERNET SETUP

This procedure is only needed when the equipment is supplied with DICOM functions (optional).

The video processor PC is supplied with the ETHERNET settings used in the factory. The Responsible Organization is accountable for changing these to suit the network to which the EM equipment is connected.

Connecting the equipment to the IT-network, the Responsible Organization should also consider that:

- connection of the equipment to an IT-NETWORK that includes other equipment could result in previously unidentified risks to **patients, operators** or **third parties**;
- Subsequent changes to the IT-network could introduce new risks and require additional analysis; changes to the IT-network include:
 - changes in the IT-network configuration,
 - connection of additional items to the IT-network,
 - disconnecting items from the IT-network,
 - update of equipment connected to the IT-network,
 - upgrade of equipment connected to the IT-network.

Warning: *The Responsible Organization should identify, analyze, evaluate and control these risks in compliance with IEC 80001-1:2010 standard.*

5.3.1 PHYSICAL CHARACTERISTICS OF THE NETWORK CONNECTIONS

Type of network connection:

- Type: Ethernet 10/100/1000 Mbits - connector RJ45.
- Rate: Autosensing 10/100/1000 Mbits.

Note: *The cabling type with the **network is the one shown below:***

Connection between two points via RJ45 crossed cable.					HUB connection via RJ45 parallel cable.				
Name	NIC1		NIC2	Name	Name	Pin	Cable Color	Pin	Name
TX+	1	---	3	RX+	TX+	1	White/Orange	1	TX+
TX-	2	---	6	RX-	TX-	2	Orange	2	TX-
RX+	3	---	1	TX+	RX+	3	White/Green	3	RX+
RX-	6	---	2	TX-		4	Green	4	
						5	White/Blue	5	
					RX-	6	Blue	6	RX-
						7	White/Brown	7	
						8	Brown	8	

5.3.2 WINDOWS SETTINGS

To set the network settings, first exit the SystemA DRF-S application and then access the PC as Administrator (see paragraph 5.3).

- Log in as **admin2** and then 'double click' on the desktop icon **Ethernet Properties:**

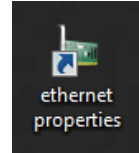

- The following frame appears:

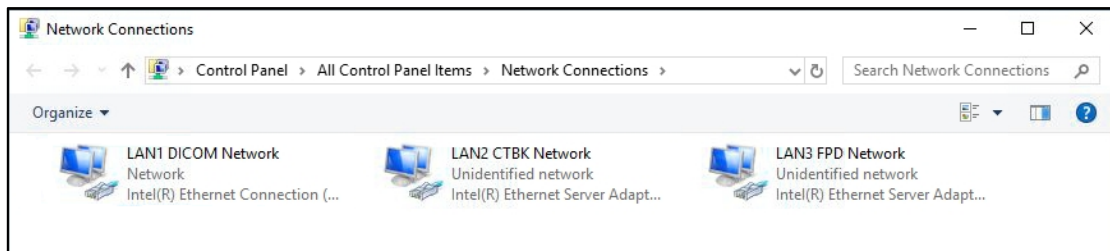

There are 3 network connections:

- **LAN1 DICOM Network** connecting the video processor to the local hospital network
- **LAN2 CTBK Network** connecting the video processor to the Main Controller board
- **LAN3 FPD Network** connecting the video processor to the detector

- Select the **LAN1 DICOM Network**; the following frame appears:

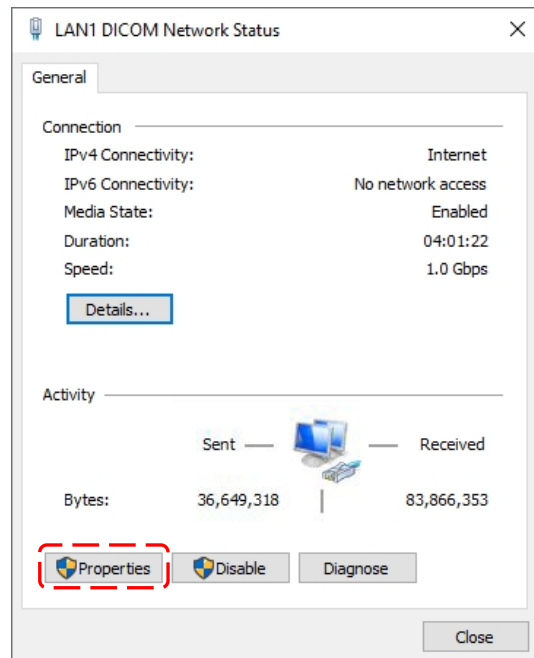

- The following frame appears when you select the **Properties** command:

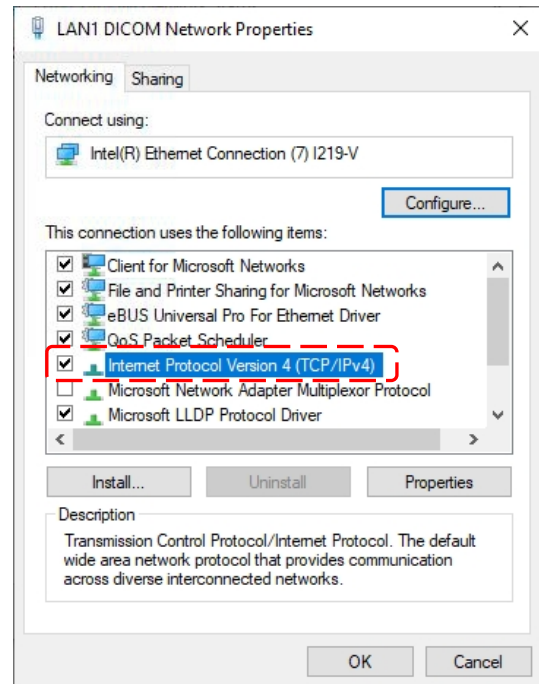

- The following frame appears when you select **Internet Protocol Version 4 (TCP/IPv4)**:
- Enter the **IP Address** and the **Subnet Mask** for the workstation in question, as agreed with the hospital network administrator.

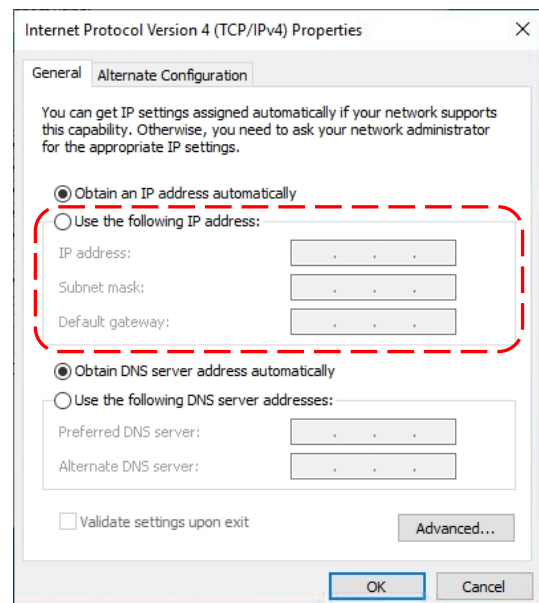

5.3.3 NETWORK CONNECTIONS TEST

After entering and confirming the network settings, you must test the connections.

- To activate the DOS prompt:
 - from the application bar, select **Start > Search**
 - enter "**cmd**" in the search box and then press **Enter**.

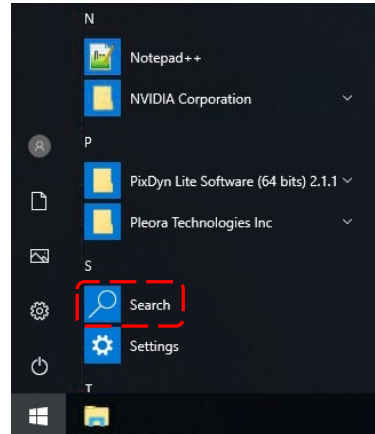

- At the DOS prompt, enter the **PING** command followed by the **IP Address** (provided by the network administrator) of another network device connected to the equipment. Then press **Enter**.
- If the screen that now appears shows **Reply** values of <1ms, the network settings are correct.

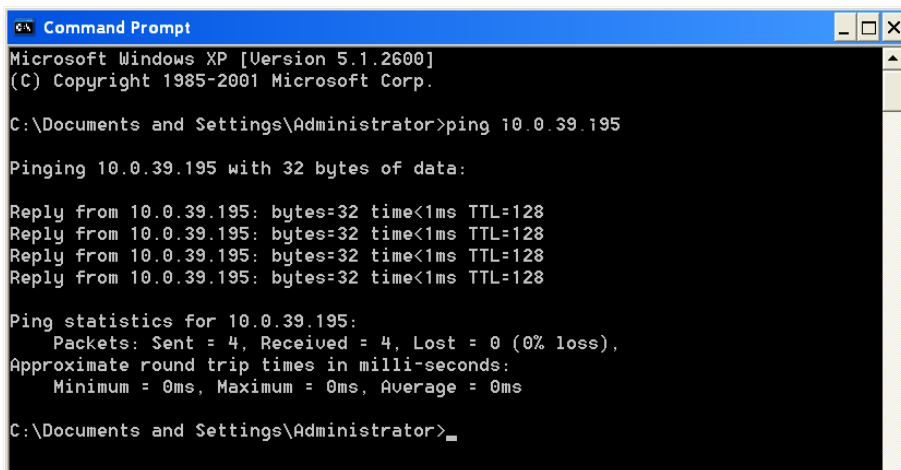

- We recommend repeating the PING command for the other devices in the network.
- If, however, the error page below appears, there is a connection failure and so you need to check both the cable and the network settings.

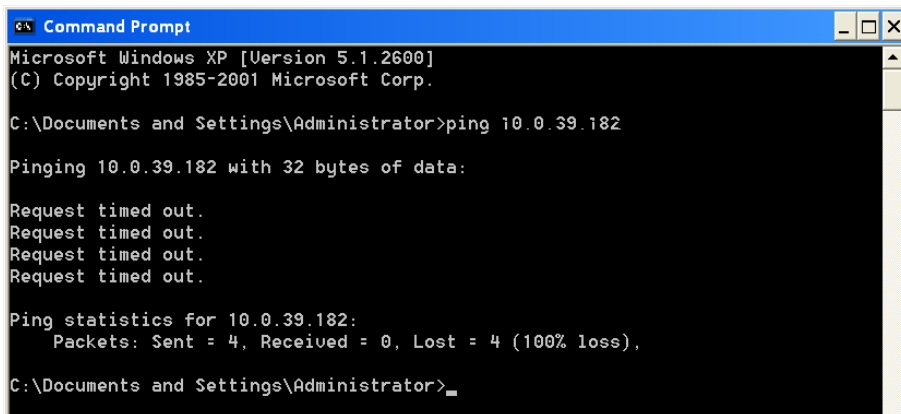

- Close the DOS window after completing the test (exit).

5.3.4 CONNECTION THROUGH WIRELESS USB ADAPTER (OPTIONAL)

When the equipment cannot be connected to network directly via a LAN cable, Wi-Fi USB will be available.

In case you are required to **replace** or make a **post-sales installation**, follow steps bellow:

- Follow instructions in previous *Paragraphs 5.4, 5.4.2 and 5.4.3*.
- Install Wi-Fi adapter drivers, provided by the EM equipment manufacturer (only in case of a post-sales installation).
- Connect the Wi-Fi adapter to one of the 2 USB ports on the stand, using the cable supplied (see *Paragraph 3.2.3, in Part 2 of this Manual*).
- Click the icon Network on the tool bar of the Desktop, too see the list of available networks.



- Select the preferred network and press **Connect**. Now, installation has been completed.

5.4 ONLINE MANUALS

The User and Technical Manual for the equipment are supplied on the monitor in PDF format. See paragraph 5.5.1 below for details on how to consult these.

5.4.1 HOW TO CONSULT THE MANUALS

- To consult the manuals, select the **user** icon from the Study List frame and then the relevant **manual** icon:



to consult the User Manual.



to consult the Technical Manual.

Both these commands cause the **Acrobat Reader** application to open and display the manual together with its list of contents (Bookmarks):

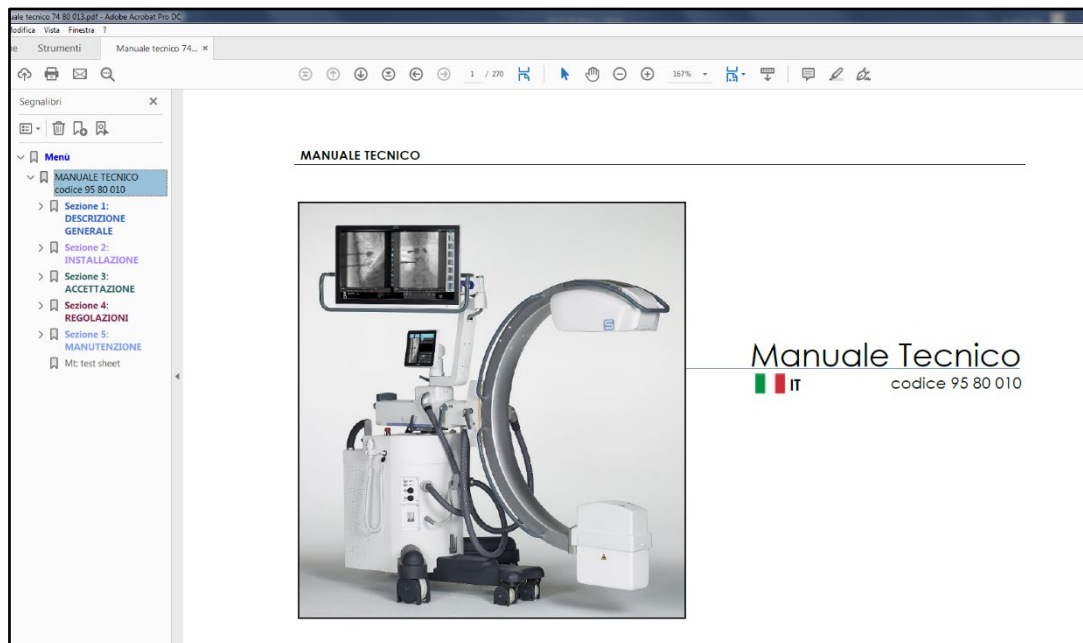

Note: For faster consultation, the list of contents has hyperlinks to each paragraph.

5.5 SOFTWARE VERSION

- To consult the list of SW versions (Administrator user only), select the **user** icon from the Study List frame and then the **setup** icon:



- Select **Software version** in the list of setups:

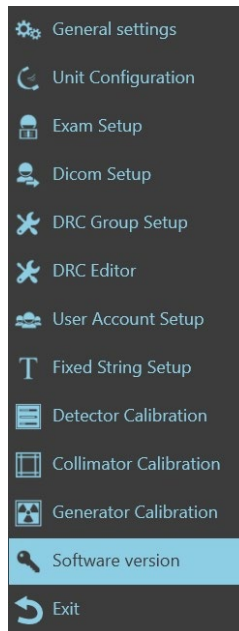

- The page showing the current SW release for the EM equipment appears:

Description	Version
SYSTEMA DRF-S	2.1.0.19085
CTBK Protocol Version	1.0
CTBK Hardware Version	1.1
CTBK-FW-S Version	0.9
CTBK Hardware SN	CTBK-HW - 5kW - RTM70 - 230V
Inverter Version	2.4
Collimator Version	UNKNOWN
API HcpCalibration64	VCP L08 2.3 (DETACHEDHEAD:c3390c0) built on Sat Sep 16 17:47:08 MDT 2017
API HcpCorrections64	VCP L08 2.3 (DETACHEDHEAD:c3390c0) built on Sat Sep 16 17:47:08 MDT 2017
API HcpFgExGigE64	VCP L08 2.3 (DETACHEDHEAD:c3390c0) built on Sat Sep 16 17:47:08 MDT 2017
API HcpImgAcq64	VCP L08 2.3 (DETACHEDHEAD:c3390c0) built on Sat Sep 16 17:47:08 MDT 2017
API HcpRecCtrl64	VCP L08 2.3 (DETACHEDHEAD:c3390c0) built on Sat Sep 16 17:47:08 MDT 2017
API Pleora Info	Version 1.0 (02.05.32); Driver: NIC native
API VirtCp64	VCP L08 2.3 (DETACHEDHEAD:c3390c0) built on Sat Sep 16 17:47:08 MDT 2017
Detector Description	PaxScan CP2 - X-ray Imager
Detector IPAddress	192.168.0.2
Detector MACAddress	00:11:1c:02:df:58
Detector ModesNumber	4
Detector PixelResolution	1024x1024
Devart Connector Version	8.6.729.0
Leadtools Version	17.0.4.0
IPP Version	7.1.1 (r37466)
Cuda Runtime Version	9.0
Option	Enabled
DicomStore	✓
DicomStorageCommitment	✓
DicomPrint	✓
DicomWorklist	✓
DicomQueryRetrieve	✓
DicomMediaExport	✓
DicomMpps	✓
DicomRDSR	✓
DSA	✓

5.6 VIDEO PROCESSOR BACK-UP

After installing the equipment, we recommend creating a back-up of the equipment setup and calibration data by saving a copy of the system hard disk:

- to a “back-up” USB PEN-DRIVE, to be kept by the technical service department.

A back-up guarantees fast recovery of the equipment functions and settings in the event of a hardware problem with the hard disk or corruption of the data held on the HD.

See Paragraph 6.1 in Part 5 of this manual for details of the back-up procedure.

5.7 CUSTOMIZATION OF THE OPENING SCREEN LOGO

The equipment lets you customize the logo that will be shown once the program booted up, in the **Login** frame.

To change the logo, just follow the procedure below:

- Login as Windows Administrator (see Paragraph 5.2 above).
- Choose an image and save it (.png format).
- From your desktop, using the right button of your mouse, click on **Systema DRF-S** icon - and select **Open file location**.

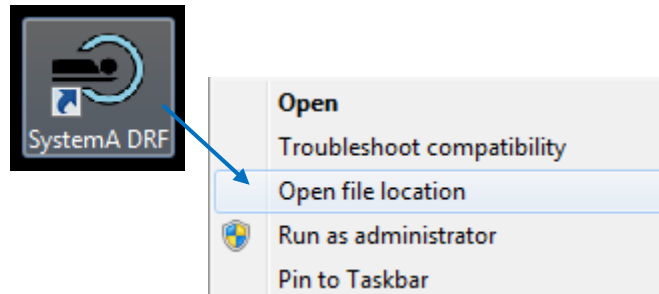

- Return to the **Systema DRF-S** folder, open the **Image** folder and import here the image previously selected. Rename your image: **p_logo**.

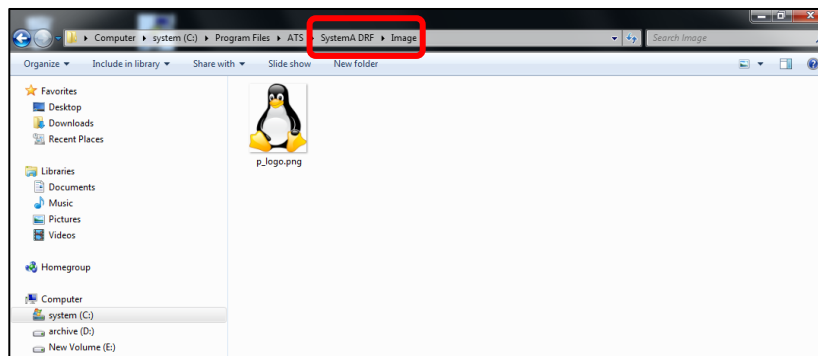

- Now you can close the folder.
Restart the Systema DRF program. In the login screen, it is shown the new logo.

PART 3: ACCEPTANCE

CONTENTS

	pages	rev.	Date
CONTENTS	I-1	0	01/03/21
1 ACCEPTANCE TEST	1.1 - 1.7	0	01/03/21
1.1 Cable and connector checks			
1.2 Mechanical checks			
1.3 Electrical and efficiency checks			
1.4 Image quality check			
1.5 Test sheet			
2 ANNEX: X-RAY DOSE AND IMAGE QUALITY CHECKS	2.1 - 2.6	0	01/03/21
2.1 X-ray dose intensity in fluoroscopy mode			
2.2 Automatic dose control function			
2.3 Image quality			
2.3.1 Grey scale			
2.3.2 Spatial resolution			
2.3.3 Noise level			
2.3.4 Low contrast resolution			
2.4 Dose Area Product meter (DAP)			
2.5 Air Kerma and Air Kerma Rate indications			

1 ACCEPTANCE TEST

The acceptance test covers all the checks and tests listed in the TEST SHEET.

The various checks and tests described below are split into the following groups:

- Cable and connector checks.
- Mechanical checks.
- Electrical and functional checks.
- Image quality check.

Each operation is identified by a code, used in the TEST SHEET.

1.1 CABLE AND CONNECTOR CHECKS

Visually check each cable and connector for signs of damage or crushing:

CHECKS	CODE
Power supply cable of the equipment	A.1
Stand cable sheath (C-arm connection).	A.2
Stand cable sheath (connection with the monitor support arm).	A.3
X-ray footswitch cable and connector.	A.4
X-ray handswitch cable and connector.	A.5
Control Panel connection cable sheath.	A.6

1.2 MECHANICAL CHECKS

Check:

- **Movement:** all movements must be smooth and easy.
- **Brakes:** brakes must be efficient and easy to engage/release.
- **Component fixing:** check for play, indicating loose screws (panels, monitors, X-ray warning light).
- **Integrity of the safety devices:** check for breakage or dents that may affect the efficiency and/or safety of the equipment.

The various checks and tests are listed below:

CHECKS	CODE
C-arm angling movement.	B.1
C-arm angling brake.	B.2
C-arm rotation.	B.3
C-arm rotation brake.	B.4
Longitudinal C-arm movement	B.5
Longitudinal C-arm movement brake.	B.6
Wig-wag C-arm movement.	B.7
Wig-wag C-arm movement brake.	B.8
Vertical C-arm movement (motorized up and down movement).	B.9
Smooth movement of stand wheels on floors.	B.10
Parking brakes on stand wheels.	B.11
±90° rotation of rear stand wheels.	B.12
Fixing of the covers on the stand.	B.17
State of the monoblock.	B.18
State of the top cover on the monoblock.	B.19
State of the Control Panel.	B.20
Orientation movement of the Control Panel.	B.21
State of the Up/Down controls on the column.	B.22
State of the emergency stop buttons.	B.23
State and function of the On/Off key.	B.24
Movements of the monitor support arm.	B.25
Up and down movements of the main monitor	B.26
Inclination movements of the main monitor	B.27
Orientation of the main monitor	B.28
Holding function of the hook for the transport position of the main monitor	B.29
Smooth movement of the anti-scatter grid carriage.	B.30
State of the anti-scatter grid.	B.31

1.3 ELECTRICAL AND EFFICIENCY CHECKS

Check:

- **Safety devices**
- **Warnings**
- **Exposure functions**
- **Compliance with radiological parameters.**

The table below sets out the full procedure, with the individual checks that appear in the **Test Sheet**.

CHECKS	CODE
- WITH THE EM EQUIPMENT SWITCHED OFF:	
Remove the stand cover	
Check the general state of the stand power unit components (dirt and corrosion).	C.1
- Reinstall the cover. Connect the X-ray command footswitch and then connect the equipment to the electricity mains.	
- SWITCH THE EQUIPMENT ON using the key switch.	
Check that the stand powers up correctly (indicated by a sequence of 4 beeps).	C.2
Check that the login screen appears on the monitor as well as on the control panel. Carry out the login and check that the test image is correctly displayed on the monitor as well as on the control panel.	C.3
Create a study or open an existing one. The dark calibration of the detector will be done automatically. After the calibration, the message READY will be displayed on the control panel indicating that the equipment is ready for acquisition.	C.4
Exit the study and give the command to shut down the equipment. Once the LED of the main monitor turns red, turn off the equipment by turning the key switch into OFF position. Wait for 10 seconds before starting the equipment again. As soon as the equipment has completed the start-up procedure, press the emergency switch button (total switch-off) and check that the entire equipment is correctly switched off.	C.5
Reset the emergency button and then switch the equipment on again.	C.6
Check the smoothness of the up/down movement of the motorized column. Use all 4 stand column control keys to do this (on the right and the left).	C.7
Press the emergency buttons for the motorized vertical movement of the column (left and right) and check that the movement is well blocked	C.8
Check the safety of the up/down movement of the motorized column (see paragraph 1.7.4 in Part 2 of the User Manual).	C.9
Select the DAILY TEST EXAM indicated in the TEST REPORT accompanying the equipment	
- Select Low Dose fluoroscopy with: Collimator fully open, FPD max field (30x30 or 21x21) and automatic kV search. Place on the X-ray monoblock, in the path of the X-ray beam one of the Aluminum filters (21 mm thick) which has been supplied with the device, Give the X-ray emission command (using the footswitch or with the handswitch) and:	
Check that the X-ray emission warning lamp lights up.	C.10
Check that the image appears on the monitor together with the FLUOROSCOPY icon and the exposure information.	C.11
Check that the image appears on the control panel together with the FLUOROSCOPY icon and the exposure information.	C.12
Check that the kV on the display are the same (or within tolerance) as those indicated on the Test Report supplied with the equipment.	C.13
Check the correct positioning of the X-ray collimator on all FPD fields.	C.14
Check that the DAP value is displayed on the monitor (see paragraph 1.7.2 in Part 2 of the User Manual).	C.15
<u>In standby</u> (using the collimator commands), check that the virtual collimators are displayed correctly on the control panel and the monitor.	C.16

CHECKS	CODE
Save an image on the hard disk and check that it is displayed on the monitor.	C.17
<p>Select High Quality fluoroscopy with:</p> <p>Collimator fully open, FPD max field (30x30 or 21x21) and automatic kV search.</p> <p>Place on the X-ray monoblock, in the path of the X-ray beam one of the Aluminum filters (21 mm thick) which has been supplied with the device,</p> <p>Give the X-ray emission command (using the footswitch or the handswitch) and then:</p>	
Check that the X-ray emission warning lamp lights up.	C.18
Check that the image appears on the monitor together with the HQ FLUOROSCOPY icon and the exposure information.	C.19
Check that the image appears on the control panel together with the HQ FLUOROSCOPY icon and the exposure information.	C.20
<p>The kV on the display are the same (or within tolerance) as those indicated on the Test Report supplied with the equipment.</p> <p>Using the 21mm Aluminum filter supplied with the equipment, check that the kV value which has been reached is the same (or within the tolerances) as the one indicated on the Test Report supplied with the equipment.</p>	C.21
Check that the DAP value is displayed on the monitor (see paragraph 1.7.2 in Part 2 of the User Manual)	C.22
<p>Select radiography mode:</p> <p>For version with 230 V AC power supply: Set 40 kV and 50 mAs.</p> <p>For version with 120 V AC power supply: Set 40 kV and 25 mAs.</p> <p>Give the X-ray emission command (with the X-ray button held down until end of exposure) and:</p>	
Check that the X-ray emission warning lamp lights up.	C.23
Check the indication of the radiography phases on the control panel: RAD PREPARATION, READY FOR RAD, RAD	C.24
Check that the image appears on the monitor together with the RADIOGRAPHY icon and exposure information.	C.25
<p>For version with 230 V AC power supply:</p> <p>Verify the exposure time reported on the Control Panel: 770ms ($\pm 15\%$).</p>	C.26
<p>For versions with 120 V AC power supply:</p> <p>Verify the exposure time reported on the Control Panel: 765ms ($\pm 15\%$).</p>	
<p>For version with 230 V AC power supply: Set 80 kV and 20 mAs.</p> <p>For version with 120 V AC power supply: Set 80 kV and 10 mAs.</p> <p>Give the X-ray emission command (with the X-ray button held down until end of exposure) and check that:</p>	
<p>For version with 230 V AC power supply:</p> <p>Verify the exposure time reported on the Control Panel: 570ms ($\pm 15\%$).</p>	C.27
<p>For version with 230 V AC power supply:</p> <p>Verify the exposure time reported on the Control Panel: 560ms ($\pm 15\%$).</p>	
Check that the DAP value is displayed on the monitor (see paragraph 1.7.2 in Part 2 of the User Manual)	C.28
<p>If the EM equipment uses the Laser Localizer (optional):</p> <p>Switch it on:</p>	
Check that the laser beam is centered on the monoblock cover.	C.29
<p>If the EM equipment uses the system printer (optional):</p> <p>Use the print command to get a printout of an image:</p>	
Check the quality of the printed image.	C.30

1.4 IMAGE QUALITY CHECK

The checks listed below let you assess the quality of the image in fluoroscopy mode. See the Annexes to this part of the manual for details on how to solve any problems.

CHECKS	Code
<p>X-ray dose intensity</p> <p>Reference value: The reference value for the X-ray dose in High Quality fluoroscopy is 24 nGy/i, that is 360 nGy/s @ 15 fps):</p> <p>These values are measured on the surface of the FPD under these conditions:</p> <ul style="list-style-type: none"> - No anti-scatter grid - 2mm Al X-ray beam filter on the monoblock. <p>Procedure: See Annex 2.1 in this part of the manual.</p>	D.1
<p>Automatic X-ray dose control</p> <p>Reference value: Adjustment of the radiological parameters (kV and/or mA) must be fast, progressive and repeatable.</p> <p>Procedure: See Annex 2.2 in this part of the manual.</p>	D.2
<p>Grey scale.</p> <p>Reference value: The manufacturer uses a "LEEDS Test GS 2" phantom to assess this parameter. All grey levels must be legible on the monitor.</p> <p>Procedure: See Annex 2.3 in this part of the manual.</p>	D.3
<p>Spatial resolution.</p> <p>Reference value: The manufacturer uses an "18-inch FUNK Resolution Test" phantom to assess this parameter. Check that the values obtained during the test are close to those indicated in the Test Report accompanying to the equipment.</p> <p>Procedure: See Annex 2.4 in this part of the manual.</p>	D.4
<p>Noise level</p> <p>Reference value: The manufacturer uses a "LEEDS Test N3" phantom to assess this parameter. The manufacturer accepts noise levels that allow for "reading" of targets with a minimum contrast percentage of no more than 2%.</p> <p>Procedure: See Annex 2.7 in this part of the manual.</p>	D.5
<p>Min contrast.</p> <p>Reference value: To assess this parameter, the manufacturer uses the phantom "Nuclear Associates model 07-645". The manufacturer accepts a minimum contrast percentage of no more than 3.5%.</p> <p>Procedure: See Annex 2.8 in this part of the manual.</p>	D.6

1.5 TEST SHEET

In addition to during acceptance, the Test Sheet should be filled in by the person responsible for the equipment:

- during routine maintenance,
- after all extraordinary maintenance.

A "blank" copy of the acceptance test is attached to this manual as one of the "loose pages".

The various controls and checks are identified by an alphanumerical code, which refers to the paragraphs above, listing the operations with a brief description.

Code	Operation	Notes	Results
A.1	Power supply cable of the equipment		
A.2	Stand cable sheath (C-arm connection).		
A.3	Stand cable sheath (connection with the monitor support arm).		
A.4	X-ray footswitch cable and connector.		
A.5	X-ray handswitch cable and connector.		
A.6	Control Panel connection cable sheath.		
B.1	C-arm angling movement.		
B.2	C-arm angling brake.		
B.3	C-arm rotation.		
B.4	C-arm rotation brake.		
B.5	Longitudinal C-arm movement		
B.6	Longitudinal C-arm movement brake.		
B.7	Wig-wag C-arm movement.		
B.8	Wig-wag C-arm movement brake.		
B.9	Vertical C-arm movement (motorized up and down movement).		
B.10	Smooth movement of stand wheels on floors.		
B.11	Parking brakes on stand wheels.		
B.12	±90° rotation of rear stand wheels.		
B.13	Fixing of the covers on the stand.		
B.14	State of the monoblock.		
B.15	State of the top cover on the monoblock.		
B.16	State of the Control Panel.		
B.17	Orientation movement of the Control Panel.		
B.18	State of the Up/Down controls on the column.		
B.19	State of the emergency stop buttons.		
B.20	State and function of the On/Off key.		
B.21	Movements of the monitor support arm.		
B.22	Up and down movements of the main monitor		
B.23	Inclination movements of the main monitor		
B.24	Orientation of the main monitor		
B.25	Holding function of the hook for the transport position of the main monitor		
B.26	Smooth movement of the anti-scatter grid carriage.		
B.27	State of the anti-scatter grid.		
B.28	C-arm angling movement.		
B.29	C-arm angling brake.		
B.30	C-arm rotation.		

Code	Operation	Notes	Results
B.31	C-arm rotation brake.		
C.1	General state of the stand power unit components (dirt and corrosion).		
C.2	Correct powering up of the stand (indicated by a sequence of 4 beeps).		
C.3	Login procedure from the monitor as well as from the Control Panel.		
C.4	Creating a new study		
C.5	Emergency shutdown.		
C.6	Restart after emergency shutdown.		
C.7	Vertical C-arm movement		
C.8	Emergency stop buttons for the vertical C-arm movement		
C.9	Vertical movement safety (see Daily Test).		
C.10	X-ray warning light and LEDs – Low Dose fluoroscopy.		
C.11	Image + indicators on monitors – Low Dose fluoroscopy.		
C.12	Image and indicators on CP for Low Dose fluoroscopy.		
C.13	Correct automatic kV search.		
C.14	Collimator: square field and parallel shutters		
C.15	DAP value.		
C.16	Indication of virtual collimators on the monitors.		
C.17	Saving of the images and transfer to the memory area of the monitor.		
C.18	X-ray warning light and LEDs – High Quality fluoroscopy.		
C.19	Image + indicators on monitors – High Quality fluoroscopy		
C.20	Image and indicators on CP for High Quality fluoroscopy.		
C.21	Correct automatic kV search.		
C.22	DAP value.		
C.23	X-ray warning light and LEDs – radiography.		
C.24	Image and indicators on CP for radiography.		
C.25	Image + indicators on monitors – radiography.		
C.26	230 V AC power supply: Radiography time for 40 kV, 50 mAs	Limits: 654 ÷ 885 ms	
	120V AC power supply: Radiography time for 40 kV, 25 mAs	Limits: 650 ÷ 880 ms	
C.27	230 V AC power supply: Radiography time for 80 kV, 20 mAs	Limits: 485 ÷ 655 ms	
	120V AC power supply: Radiography time for 80 kV, 10mAs	Limits: 476 ÷ 644 ms	
C.28	DAP value.		
C.29	Centering of Laser Localizer (<i>optional</i>)		
C.30	Video printer (<i>optional</i>)		
D.1	X-ray dose intensity.		
D.2	Automatic X-ray dose control.		
D.3	Grey scale.		
D.4	Spatial resolution.		
D.5	Noise level.		
D.6	Min contrast.		

2 ANNEX: X-RAY DOSE AND IMAGE QUALITY CHECKS

2.1 X-RAY DOSE INTENSITY IN FLUOROSCOPY MODE

During installation, the EM equipment can be configured to work with different X-ray doses to suit specific exam types.

Below are details of the measuring conditions and the typical dose rates defined for the equipment:

Low Dose fluoroscopy: 12nGy/i

High Quality fluoroscopy: 24nGy/i

Measuring conditions:

- Additional X-ray beam filtering with a **21mm Aluminum filter** on the X-ray monoblock.
- X-ray dose measured on the front surface of the FPD (**no grid**).
- Select exam **DAILY TEST**.

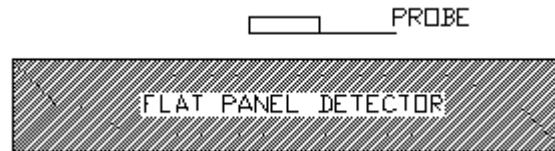

- Procedure:
- Select the exam "EXTREMITY",
 - Select the frame rate 15 i/s.

 - Give the X-ray emission command in the mode intended for the test and wait until the kV and mA adjustment is stabilized.
 - Make sure the measured dose is $\pm 20\%$ the expected value.

• LOW DOSE FLUOROSCOPY, FPD NOMINAL FIELD 21 x 21cm² or 30 x 30cm²

MEASURED DOSE	kV /mA _{avg} (@ 15 fps)
12 nGy/i	55 / 1,58

• HIGH QUALITY FLUOROSCOPY, FPD NOMINAL FIELD 21 x 21cm² or 30 x 30cm²

MEASURED DOSE	kV /mA _{avg} (@ 15 fps)
24 nGy/i	55 / 3,8

2.2 AUTOMATIC X-RAY DOSE CONTROL FUNCTION

Check that the automatic X-ray parameter adjustment (kV and mA) is quick and repeatable.

Conditions:

- Exam "EXTREMITY",
- Fluoroscopy with automatic X-ray dose control,
- Frame Rate: 4 fps
- Flat Panel Detector nominal field (30x30cm or 21x21cm),
- X-ray beam filtered using a 1mm copper filter on the X-ray monoblock.

Procedure:

- Manually set 90 kV and give the X-ray command. Check that the equipment automatically adjusts the kV to the value shown in the previous paragraph ± 1 kV) within 1 second and without oscillation.
- Set 40kV and give the X-ray command. Check that the equipment automatically adjusts the kV to the value shown in the previous paragraph (tolerance: ± 1 kV) within 1 second and without oscillation.

2.3 IMAGE QUALITY

Below are the tests and conditions used to check the image quality.

The results for each EM equipment are provided in the corresponding **Test Report** (attached).

2.3.1 GREY SCALE

The grey scale is checked using a UNIVERSITY OF LEEDS Test GS2 phantom:

Measuring conditions:

- Exam EXTREMITY.
- 1 mm copper filter on the X-ray monoblock.
- LEEDS Test GS2 phantom on the face of the FPD.
- Flat Panel Detector nominal field (30x30 or 21x21).
- Frame Rate: 4 fps
- Automatic X-ray dose control.

Procedure:

Acquire images in **Low Dose** and **High Quality** fluoroscopy and check that all gray levels of the phantom are visible.

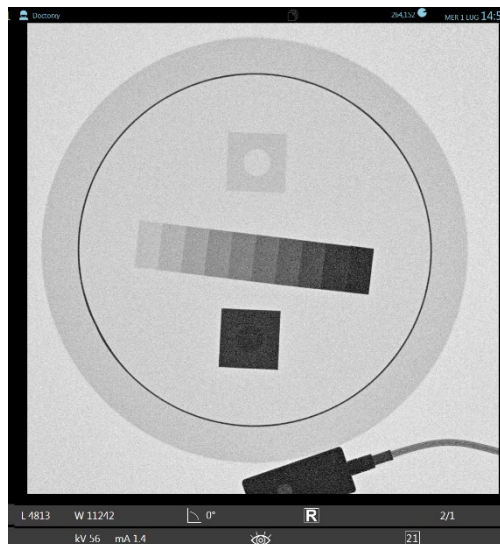

GS2
test object

2.3.2 SPATIAL RESOLUTION

Spatial resolution is measured with:

- **FUNK type 18** resolution test, (or equivalent) at 45° on the FPD (as shown in the drawing below).

Measuring conditions:

- Exam EXTREMITY
- No X-ray beam filtering (use only the collimator filter already set for the exam).
- Frame Rate: **4 fps**.
- Automatic X-ray dose control.

Acquire images in Fluoroscopy (LD and HQ) and Radiography modes and read the number of pair of lines on the monitor.

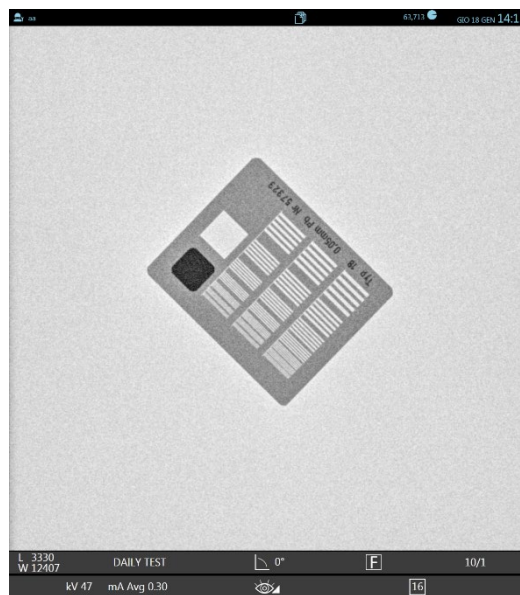

Resolution Type
18

The table below shows the typical values, for **Low Dose** fluoroscopy, **High Quality** fluoroscopy and **Radiography**.

FPD 30x30 FIELD SIZE	Low Dose (lp/mm)	High Quality (lp/mm)	Radiography (lp/mm)
30x30	2.5	2.8	3.15
21x21	2.8	3.15	/
16x16	2.8	3.15	/

FPD 21x21 FIELD SIZE	Low Dose (lp/mm)	High Quality (lp/mm)	Radiography (lp/mm)
21x21	2.8	3.15	3.15
16x16	3.15	3.55	/
12x12	3.15	3.55	/

Note: Check that the values are close to those indicated in the Test Report attached to the equipment.

2.3.3 NOISE LEVEL

The noise level is checked using the LEEDS Test N3 phantom.

[This test is based on the use of a phantom with 19 circular targets having the same diameter, but different contrast: the lowest contrast target visible indicates the actual noise level.]

Measuring conditions:

- Exam EXTREMITY.
- 1 mm copper filter on the X-ray monoblock.
- LEEDS Test N3 phantom on the face of the FPD.
- Detector field: **21x21**.
- Frame rate: **4 fps**.
- Automatic X-ray dose control.

Procedure:

- Acquire images in **Low Dose** and **High-Quality** fluoroscopy.
- Count how many targets are clearly visible on the monitor.

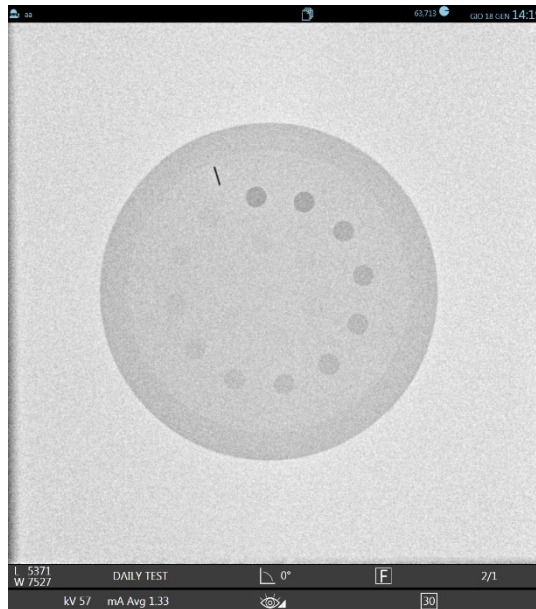

N3
test object

The table below shows the typical values for the two acquisition modes.

Mode	N° targets
LD Fluoroscopy	12
HQ Fluoroscopy	14

Note: Check that the values are close to those indicated in the Test Report attached to the equipment.

2.3.4 LOW CONTRAST RESOLUTION

The low contrast resolution is checked using the LEEDS Test TO10 phantom.

Measuring conditions:

- Exam **EXTREMITY**
- 1 mm copper filter on the X-ray monoblock.
- LEEDS Test TO10 phantom on the face of the FPD.
- Detector field: **21x21**.
- Frame rate: **4 fps**.
- Automatic X-ray dose control.

Procedure:

- Acquire images in **Low Dose** and **High-Quality** fluoroscopy and establish how many details are clearly visible (each series, indicated by a letter, has 9 details).

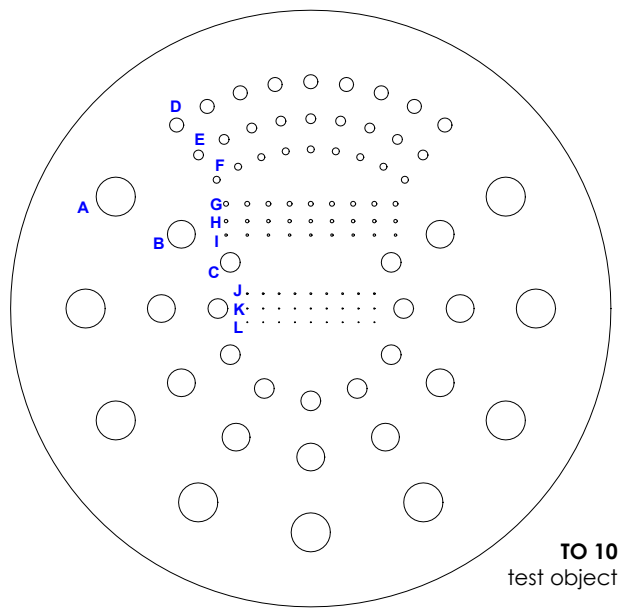

Selected	Visible details (typical values)	
	LD Fluoroscopy	HQ Fluoroscopy
A	7	8
B	7	8
C	7	8
D	7	7
E	7	7
F	6	7
G	7	7
H	6	7
I	6	6
J	5	6
K	3	4
L	3	3

2.4 DOSE AREA PRODUCT METER (DAP)

See paragraph 2.1.4.1 in Part 4 of this Manual.

2.5 AIR KERMA AND AIR KERMA RATE INDICATIONS

See paragraph 2.1.4.2 in Part 4 of this Manual.

Part 4: ADJUSTMENTS

CONTENTS

	pages	rev.	Date
CONTENTS	I-1	0	01/03/21
1 GENERAL INFORMATION	1.1	0	01/03/21
1.1 Introduction			
2 ADJUSTMENTS	2.1 - 2.30	0	01/03/21
2.1 X-ray generator adjustment			
2.1.1 General			
2.1.2 Fluoroscopy			
2.1.2.1 Pulsed fluoroscopy			
2.1.2.2 Continuous fluoroscopy			
2.1.3 Digital radiography (Snapshot)			
2.1.4 DAP, Air-Kerma & Auto kV			
2.1.4.1 DAP calibration factor			
2.1.4.2 Air-Kerma rate calibration factor			
2.1.4.3 Auto kV calibration			
2.1.5 Checking the kV and mA			
2.2 Adjusting the X-ray collimator			
2.2.1 Centering the X-ray collimator			
2.2.1.1 Centering the shutters			
2.2.1.2 Centering the square field			
2.3 Adjusting the laser beam centering devices			
2.3.1 Adjusting the laser devices on the monoblock			
2.3.2 Adjusting the laser devices on the FPD			
2.4 Adjusting the up/down column movement			
3 DETECTOR CALIBRATION	3.1 - 3.5	0	01/03/21
3.1 Introduction			
3.2 Finding the exposure values for calibration			
3.3 Calibration procedure			
3.3.1 Fluoroscopy calibration of detector 3030			
3.3.2 Fluoroscopy calibration of detector 2121			
3.3.3 Radiography calibration			
4 ANNEXES	4.1 - 4.3	0	01/03/21
4.1 Potentiometer list			
4.2 LED list			
4.3 Fuse list			

1 GENERAL INFORMATION

1.1 INTRODUCTION



The EM equipment is fully adjusted in the factory.

During its installation, the equipment simply needs to be setup, as described in Chapter 4 in Part 2 above.

The information given in this section of the manual is needed to adjust/calibrate the equipment during routine maintenance or after replacing components.

The following abbreviations will be used, where possible, in this manual for the electronic boards:

Stand boards:	CTBK-HW 00 board	=	B1
	ASAC 01 board	=	B2
X-ray generator board:	S219	=	S219
Infrared remote-control board:	CTIR-HW 00 board	=	B3

There are basically six areas of adjustment/calibration:

- Adjusting the X-ray generator (see Paragraph 2.1).
- Adjusting the X-ray collimator (see Paragraph 2.2).
- Adjusting the laser beam centering devices (see Paragraph 2.3).
- Adjusting the up/down column movement (see Paragraph 2.4).
- Calibration of the Flat Panel Detector (see chapter 3).

2 ADJUSTMENTS

2.1 ADJUSTING THE X-RAY GENERATOR

The procedure for adjusting the X-RAY GENERATOR is split into the following menus:



- **General:** calibration of the **set kV** parameter,
- **Pulsed Fluoro:** For the calibration of the **filament current** in pulsed fluoroscopy,
- **Continuous Fluoro:** for the calibration of the **filament current** in continuous fluoroscopy,
- **Snapshot:** calibration of the **filament current** in Digital Radiography mode,
- **DAP, Kerma & Auto kV:** calibration of the **DAP** and the **Air-Kerma** values and setting of the **automatic kV adjustment** parameters.

2.1.1 GENERAL

This menu lets you set the percentage of correction for the **set kV** value sent to the X-RAY GENERATOR, so that the actual kV value matches the set value.

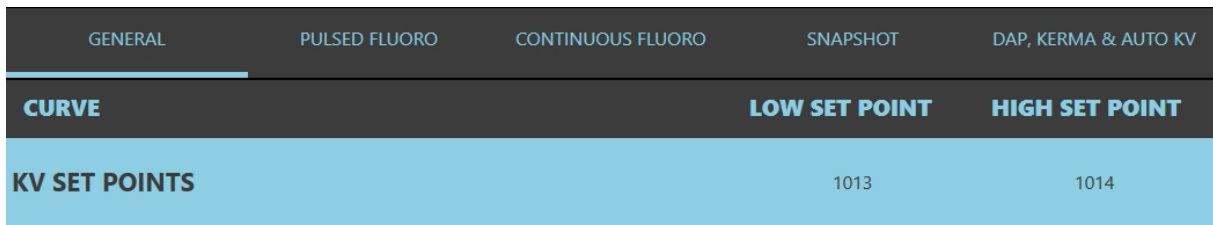

To calibrate the **Set kV**, 'double touch' the **KV SET POINTS** field. The following panel opens:

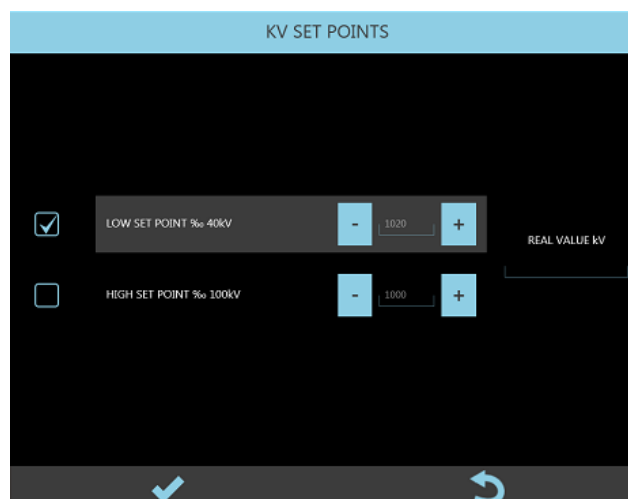

Calibration of the **Set kV** involves setting two kV values:

- LOW SET POINT: 40kV
- HIGH SET POINT: 100kV

You can change the SET POINTS within the range of 80% (800‰) and 120% (1200‰). The value 1000 ‰ corresponds to no correction; in this case, the nominal value of the **Set kV** is sent 'as is' to the X-ray generator.

Calibration is carried out as follows:

- 1) Select **LOW SET POINT ‰ 40kV**:
the equipment automatically sets **HQ Fluoroscopy, 40 kV and 15 FPS**.
- 2) Give the X-ray command and read the value shown in the **Real Value kV** field, on the right.
- 3) If this reading differs from the set value by ± 1 kV, you need to correct proportionally the parameter "**LOW SET POINT ‰ 40kV**".

For example:

- Measured kV value = 42 kV
- Current value "LOW SET POINT ‰ 40kV" = 1000
- Reduce "LOW SET POINT ‰ 40kV" to: $(40/42)*1000 = 952$

- 4) Select **HIGH SET POINT ‰ 100kV**:
the equipment automatically sets **HQ Fluoroscopy, 100 kV and 15 FPS**.
- 5) Give the X-ray command and read the value shown in the **Real Value kV** field, on the right.
- 6) If this reading differs from the set value by ± 1 kV, you need to correct the **HIGH SET POINT ‰ 100 kV** parameter proportionally.

For example:

- Measured kV value = 95 kV.
- Current value "HIGH SET POINT ‰ 100kV" = 1000
- Increase "HIGH SET POINT ‰ 100kV" to: $(100/95)*1000 = 1052$

2.1.2 FLUOROSCOPY

The EM equipment uses the following mA curves in **FLUOROSCOPY** emission modes (see table below).

Version with rotating anode

FRAME RATE: UP TO 15 FPS			
mA curve	FOCUS	mA RANGE / SET POINT	NOTES
PULSED CURVE 1: SF 0.4 – 10mA	Small	40kV - 0.4mA / low set point	
		70kV - 10mA /high set point	
PULSED CURVE 2: SF 1.6 – 40mA	Small	40kV – 1.6mA / low set point	
		70kV - 40mA /high set point	
PULSED CURVE 3: LF 0.4 – 10mA	Large	40kV - 0.4mA / low set point	
		70kV - 10mA /high set point	
PULSED CURVE 4: LF 1.6 – 40mA	Large	40kV - 1.6mA / low set point	
		70kV - 40mA /high set point	

FRAME RATE: 30 FPS			
mA curve	FOCUS	mA RANGE / SET POINT	NOTES
CONTINUOUS CURVE 1: SF 0.1 – 2.5mA	Small	40kV - 0.1mA / low set point	
		70kV – 2.5mA /high set point	
CONTINUOUS CURVE 2: SF 0.2 – 5mA	Small	40kV – 0.2mA / low set point	
		70kV - 5mA /high set point	
CONTINUOUS CURVE 3: LF 0.1 – 2.5mA	Large	40kV - 0.1mA / low set point	
		70kV – 2.5mA /high set point	
CONTINUOUS CURVE 4: LF 0.2 – 5mA	Large	40kV – 0.2mA / low set point	
		70kV - 5mA /high set point	

2.1.2.1 PULSED FLUOROSCOPY

The PULSED FLUOROSCOPY menu lets you calibrate each mA curve for the pulsed fluoroscopy.

GENERAL	PULSED FLUORO	CONTINUOUS FLUORO	SNAPSHOT	DAP, KERMA & AUTO KV
CURVE			LOW SET POINT	HIGH SET POINT
PULSED CURVE 1: SF 0.4 - 10mA			995	979
PULSED CURVE 2: SF 1.6 - 40mA			1029	993
PULSED CURVE 3: LF 0.4 - 10mA			967	971
PULSED CURVE 4: LF 1.6 - 40mA			969	951

Calibration of a mA curve involves adjusting the filament current at 2 points in the curve (LOW SETPOINT and HIGH SETPOINT) to get the required mA value.

For example, in the case of **PULSED CURVE 1** the values of the 2 set points are:

- **40 kV – 0.4 mA,**
- **70 kV – 10 mA.**

Select the curve you want to calibrate by 'double touching' (tapping) the relevant field (e.g. **PULSED CURVE 1: ...**).

The following menu opens:

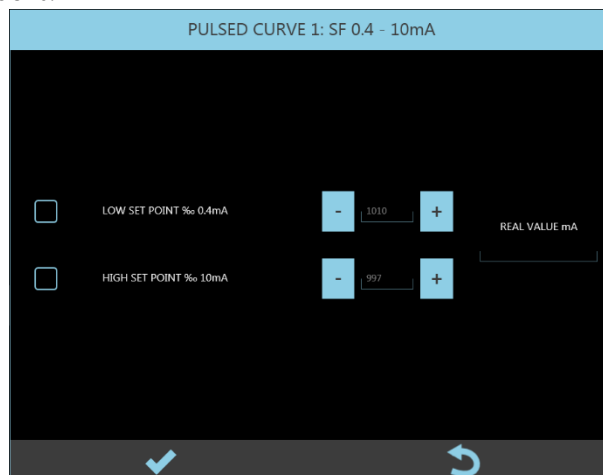

Adjust the setpoints, from 80% (800‰) to 120% (1200‰) of the nominal value, to correct the filament current in order to get the mA value envisaged for the setpoint.

Value 1000‰ corresponds to no correction.

For example, in the case of **PULSED CURVE 1**:

- 1) Select "**LOW SET POINT % 0.4mA**":
the equipment automatically sets **HQ Fluoroscopy, 40 kV and 15 FPS**.
- 2) Command x-ray emission and read the value shown in the Real Value mA field, on the right.

3) No correction is required if this value matches the expected value: 0.4 mA ($\pm 5\%$).

Otherwise:

- If the REAL VALUE mA is lower than expected: increase the "LOW SET POINT % 0.4mA":
- If the REAL VALUE mA is higher than expected: reduce the same parameter.

4) Select "**HIGH SET POINT % 10mA**":

The equipment automatically sets HQ Fluoroscopy, 70 kV and 15 FPS.

5) Command x-ray emission and read the value shown in the Real Value mA field, on the right.

6) No calibration is required if this value matches the expected value: **10 mA ($\pm 5\%$)**.

Otherwise:

- If the REAL VALUE mA is lower than expected: increase the "HIGH SET POINT % 10mA",
- If the REAL VALUE mA is higher than expected: reduce the same parameter.

Repeat this procedure for each mA curve foreseen by the equipment (see table above).

2.1.2.2 CONTINUOUS FLUORO

The CONTINUOUS FLUORO menu lets you calibrate each mA curve for the continuous fluoroscopy.

GENERAL	PULSED FLUORO	CONTINUOUS FLUORO	SNAPSHOT	DAP, KERMA & AUTO KV
CURVE			LOW SET POINT	HIGH SET POINT
CONTINUOUS CURVE 1: SF 0.1 - 2.5mA			919	897
CONTINUOUS CURVE 2: SF 0.2 - 5mA			917	859
CONTINUOUS CURVE 3: LF 0.1 - 2.5mA			920	890
CONTINUOUS CURVE 4: LF 0.2 - 5mA			910	854

Calibration of a mA curve involves adjusting the filament current at 2 points in the curve (LOW SETPOINT and HIGH SETPOINT) to get the required mA value.

For example, in the case of **CONTINUOUS CURVE 1** the values for the 2 set points are:

- **40 kV – 0.1 mA,**
- **70 kV – 2.5 mA.**

Select the curve you want to calibrate by 'double touching' the relevant name (e.g. **CONTINUOUS CURVE 1: ...**). The following menu opens:

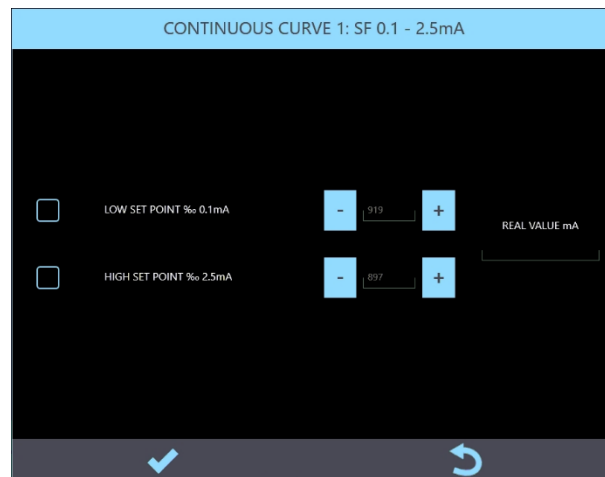

Adjust the setpoints, from 80% (800‰) to 120% (1200‰) of the nominal value, to correct the filament current in order to get the mA value envisaged for the setpoint.

The value 1000‰ corresponds to no correction.

For example, in the case of **CONTINUOUS CURVE 1**:

- 7) Select "**LOW SET POINT ‰ 0.1mA**":
the equipment automatically sets **HQ Fluoroscopy, 40 kV and 30 FPS**.
- 8) Command x-ray emission and read the value shown in the Real Value mA field, on the right.
- 9) No correction is required if this value matches the expected value: 0.1mA ($\pm 5\%$).

Otherwise:

- If the REAL VALUE mA is lower than expected: increase the "LOW SET POINT ‰ 0.4mA":
- If the REAL VALUE mA is higher than expected: reduce the same parameter.

- 10) Select "**HIGH SET POINT ‰ 2.5mA**":
The equipment automatically sets HQ Fluoroscopy, 70 kV and 30 FPS.
- 11) Command x-ray emission and read the value shown in the Real Value mA field, on the right.
- 12) No calibration is required if this value matches the expected value: **2.5mA ($\pm 5\%$)**.

Otherwise:

- If the REAL VALUE mA is lower than expected: increase the "HIGH SET POINT ‰ 10mA",
- If the REAL VALUE mA is higher than expected: reduce the same parameter.

Repeat this procedure for each mA curve foreseen by the equipment (see table above).

2.1.3 DIGITAL RADIOGRAPHY (SNAPSHOT)

The equipment uses the mA curves shown in below for X-ray emissions in RADIOGRAPHY mode.

Version with rotating anode

mA curve	FOCUS	mA RANGE / SET POINT	NOTES
RAD CURVE 1: SF 100kV – 28mA	Small	40kV - 65mA / low set point	Isowatt power = 2.8 kW
		100kV - 28mA /high set point	
RAD CURVE 2: SF 100kV – 40mA	Small	40kV - 100mA / low set point	For exposure times with Joule < 1000 Isowatt power = 4kW (with Joule > 1000 RAD CURVE 1 is automatically selected)
		100kV - 40mA /high set point	
RAD CURVE 3: LF 100kV – 28mA	Large	40kV - 65mA / low set point	Isowatt power = 2.8 kW
		100kV - 28mA /high set point	
RAD CURVE 4: LF 100kV – 40mA	Large	40kV - 100mA / low set point	For exposure times with Joule < 1000 Isowatt power = 4kW For Rx exposure times with Joule > 1000 RAD CURVE 3 is automatically selected)

The SNAPSHOT menu lets you calibrate each mA curve.

GENERAL	PULSED FLUORO	CONTINUOUS FLUORO	SNAPSHOT	DAP, KERMA & AUTO KV
CURVE		LOW SET POINT	HIGH SET POINT	
RAD CURVE 1: SF 100kV - 28mA		983	980	
RAD CURVE 2: SF 100kV - 40mA		996	980	
RAD CURVE 3: LF 100kV - 28mA		962	966	
RAD CURVE 4: LF 100kV - 40mA		931	936	

As for X-ray emissions in fluoroscopy modes, calibration of a mA curve involves adjusting the filament current at 2 points in the curve (LOW SETPOINT and HIGH SETPOINT) to get the required mA value.

For example, the values of the 2 setpoints in the case of **RAD CURVE 1** are:

- 40 kV – 65 mA,
- 100 kV – 28 mA.

Select the curve you want to calibrate by 'double touching' the relevant field (e.g. **RAD CURVE 1: ...**).

The following menu opens:

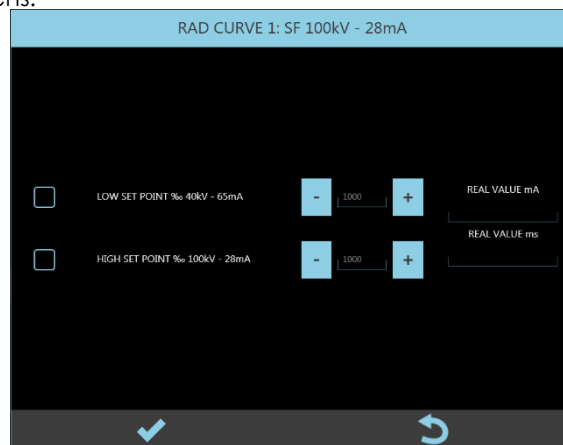

Adjust the setpoints, from 80% (800‰) to 120% (1200‰) of the nominal value, to correct the filament current and so get the mA envisaged for the setpoint.

Value 1000‰ corresponds to no correction.

For example, in the case of **RAD CURVE 1**:

- 1) Select LOW SET POINT % 40 kV – 65 mA.
The equipment automatically sets an exposure at 40 kV and 5 mAs.
- 2) Command x-ray emission and read the value shown in the Real Value mA field, on the right.

- 3) No calibration is required if the Real Value mA matches the expected value: 65 mA ($\pm 5\%$).
Otherwise:
 - If the REAL VALUE mA is lower than expected: increase the "LOW SET POINT $\%$ 40kV- 65mA":
 - If the REAL VALUE mA is higher than expected: reduce the same parameter.
- 4) Select "HIGH SET POINT $\%$ 100kV – 28mA".
The equipment automatically sets an exposure at 100 kV and 5 mAs.
- 5) Command x-ray emission and read the value shown in the Real Value mA field, on the right.
- 6) No calibration is required if the Real Value mA matches the expected value: 28mA ($\pm 5\%$).
Otherwise:
 - If the REAL VALUE mA is lower than expected: increase the "HIGH SET POINT $\%$ 100kV- 28mA":
 - If the REAL VALUE mA is higher than expected: reduce the same parameter.

➤ **Note:** After exposure, check that:

$$\text{REAL VALUE mA} * \text{REAL VALUE ms} = 5\text{mAs} (\pm 5\%).$$

Repeat this procedure for each mA curve foreseen by the equipment (see table above).

2.1.4 DAP, AIR-KERMA & AUTO kV

This menu lets you:

- Calibrate the value of the DOSE AREA PRODUCT received from the DAP meter.
- Calibrate the value of the AIR-KERMA calculated by the system.
- Calibrate the automatic kV control.

GENERAL	PULSED FLUORO	CONTINUOUS FLUORO	SNAPSHOT	DAP, KERMA & AUTO KV
CALIBRATION ITEM				CURRENT VALUE
DAP CALIBRATION FACTOR ‰				1000
KERMA CALIBRATION FACTOR ‰				1000
DOSE % FOR kV +++				20
DOSE % FOR kV ++				30
DOSE % FOR kV +				50
DOSE % FOR kV -				200
DOSE % FOR kV --				500
DOSE % FOR kV ---				1000
% HISTERESYS				6

2.1.4.1 DAP CALIBRATION FACTOR

The Dose Area Product meter (DAP) is checked by comparing the indication on the Live Monitor against that calculated using an external reference dosimeter.

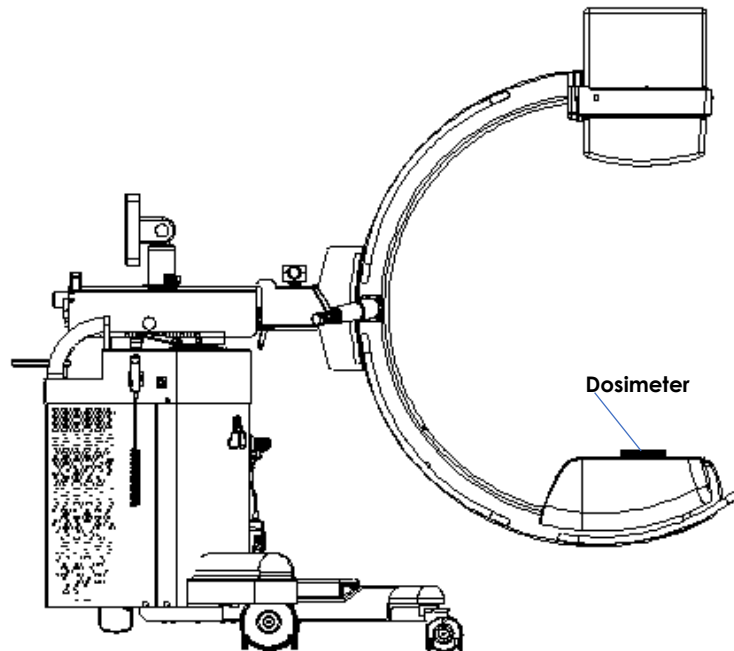

To do this:

- 1) In General Setup menu, set **mGy*cm²** as the dose unit of measurement (see Paragraph 4.2, Part 2 of this Manual).
- 2) Place an external dosimeter on the **detector**, and then set it for readings in **mGy**.
- 3) Open a new study, select **HQ Fluoroscopy**, **acquisition rate: 8 fps**, **detector field zoom: 16**.
- 4) Set **60 kV** and **Manual dose control**.
- 5) Give the fluoroscopy command for about 10-15 seconds and make a note of the reading on the dosimeter.
- 6) Multiply the dosimeter reading (**mGy**) by the value of the sensitive area: since it has been set FPD field: 16, the area is 16cm * 16cm = **256cm²**.
- 7) Calculate the ratio **R** between the value of the read "**dose x area**" and that shown on the Live Monitor.

Example:

- radiated FPD area:	256 cm ²
- dosimeter reading:	0,253 mGy
- calculated dose*area:	0.253 mGy x 256 cm ² = 64.8 mGy x cm²
- Live Monitor reading:	61 mGy x cm²

- ratio between the 2 indications: **R = calculated value / monitor value = 1.06**

- 8) Open Setup and select **Generator Calibration** menu; open **Dap, Kerma and Auto kV** sub-menu and select **DAP CALIBRATION FACTOR** (tap on this option). The following panel appears:

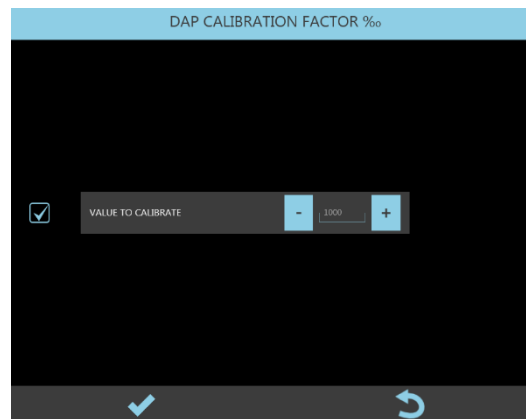

- 9) Calculate:

- New DAP CALIBRATION FACTOR = actual CALIBRATION FACTOR * R.

Note: The DAP CALIBRATION FACTOR settings range is 500 ÷ 1500‰.

2.1.4.2 AIR-KERMA RATE CALIBRATION FACTOR

The AIR-KERMA RATE is checked by comparing the AIR-KERMA RATE shown on the Live Monitor against that read by a reference dosimeter placed at the PATIENT ENTRY REFERENCE POINT.

The PATIENT ENTRY REFERENCE POINT is on the X-ray axis, 30 cm from the detector, using the measuring conditions specified by standard EN 60601-2-54 (paragraph 203.6.3.102), as shown in the figure below.

Standard EN 60601-2-54 (203.5.2.4.5.101) foresees a display tolerance of 50%.

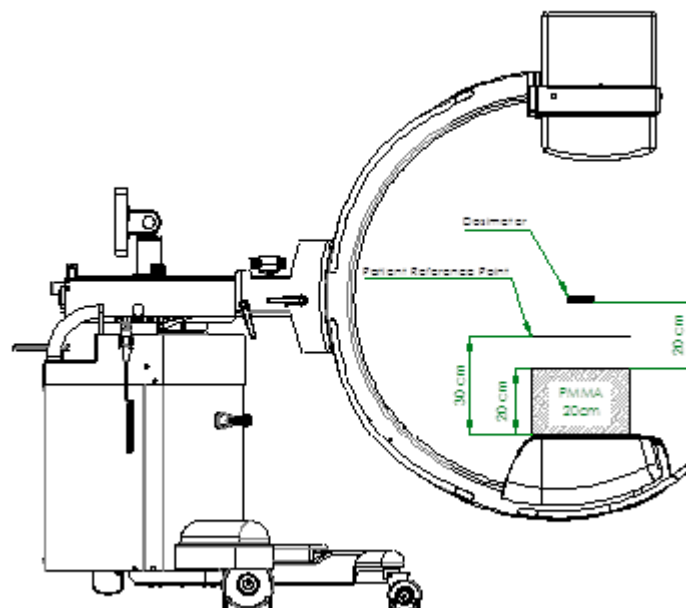

To do this check:

- 1) Place the reference dosimeter at the REFERENCE POINT OF ENTRY ON PATIENT and set this for readings in mGy/min.
- 2) Open a new study.
- 3) Set: **HQ Fluoroscopy, 70 kV**, acquisition rate **8 fps**, detector field: **16 cm**.
- 4) Give the X-ray emission command and make a note of the reading on the dosimeter.
- 5) Calculate the ratio **R** between the measured AIR-KERMA RATE and that shown on the monitor.

Example: - AIR-KERMA RATE read by the dosimeter: 2.8 $\mu\text{Gy}/\text{min}$
 - AIR-KERMA RATE shown on the monitor: 3.3 $\mu\text{Gy}/\text{min}$
 - ratio between the 2 indications: $R = 2.8 / 3.3 = 0,84$.
 - error between the 2 indications in %: $(3.3 - 2.8) / 2.8 * 100 = 17.8\%$.

- 6) Select **KERMA CALIBRATION FACTOR**, with double tap. The following panel appears:

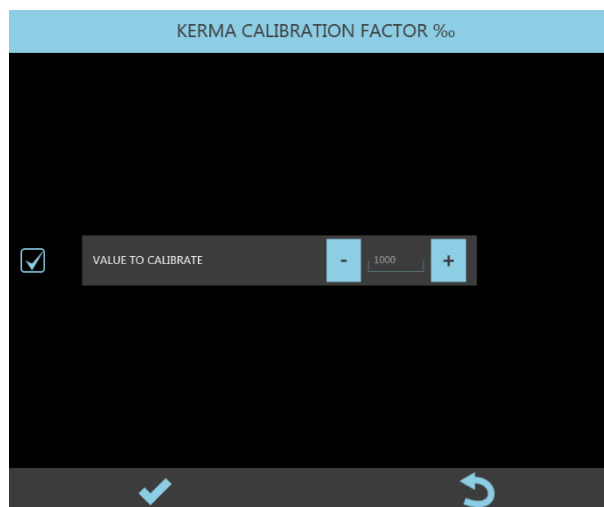

- 7) Calculate:

- new KERMA CALIBRATION FACTOR = actual CALIBRATION FACTOR * **R**.

Example: - actual KERMA CALIBRATION FACTOR = 1020 (102%),
 - $R = 0.84$ (as in the previous example),
 - corrected KERMA CALIBRATION FACTOR = $1020 * 0.84 = 856$.

The KERMA CALIBRATION FACTOR settings range is 500 - 1500‰.

2.1.4.3 AUTO kV CALIBRATION

The working X-ray dose is set, for each acquisition mode, in the EXAM SETUP menu.

The automatic dose control function (ADC) can be enabled for FLUOROSCOPY. This function automatically sets the required value of the kV and correlated mA so that the actual value of the dose is always the same as that set in the exam card (Target Dose).

The equipment calculates the X-ray dose in terms of image levels from the detector.

Note: The dose in nGy is obtained by dividing the image levels by the sensitivity of the detector (lsb/nGy). The table below provides an example.

Image levels	Nominal detector sensitivity (Typ.)	X-ray dose
200	10 lsb/nGy	20 nGy/i

The ADC function constantly checks the difference between the TARGET DOSE and the ACTUAL DOSE and adjusts the kV of a set value, depending on this difference: the variation in the kV will be small if the actual dose is close to the target dose; on the other hand, the variation in the kV will be greater if this difference is substantial.

To calibrate this function, you need to set:

- 6 adjustment thresholds (% of the TARGET DOSE level): 3 to increase the kV and 3 to reduce it,
- a hysteresis threshold (% of the TARGET DOSE level): the ADC function stops adjusting the kV if the deviation (%) of the ACTUAL DOSE from the TARGET DOSE is below this hysteresis threshold.

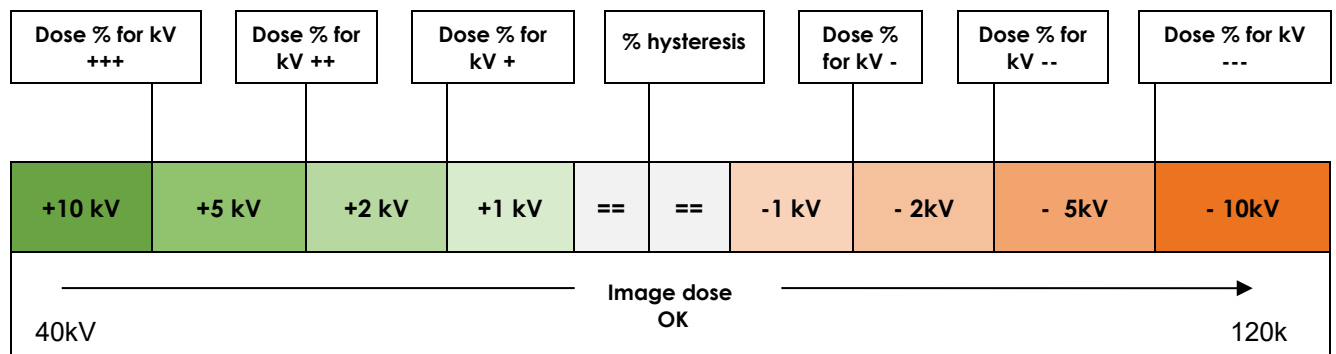

- 1)
- 2) Place a 2mm copper filter on the monoblock cover.
Select **% HYSTERESIS**:

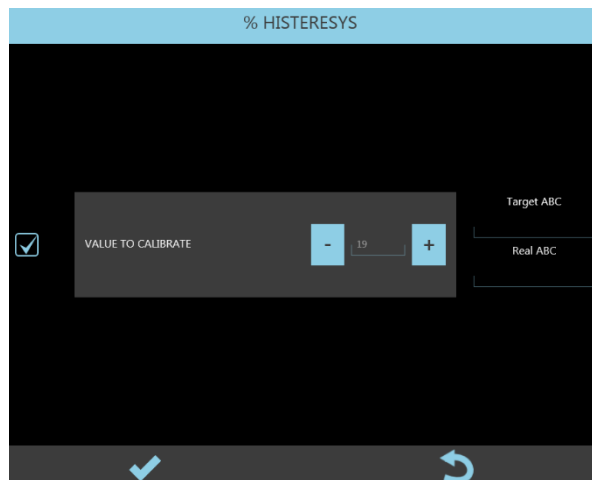

- 3) The equipment automatically sets **HQ Fluoroscopy** with **Automatic Dose Control**. Then set **40 kV**.
- 4) Give the X-ray emission command and check the system reaches the correct dose.
- 5) Release the X-ray command and make a note of the kV reached.
- 6) Now set the kV previously noted (+1kV and – 1kV). Give the X-ray command and check that the kV always reach the noted value.
- 7) If this value is still +/- 1 kV, lower the **% HYSTERESIS** and repeat the process.
- 8) Select **DOSE % FOR kV-** :

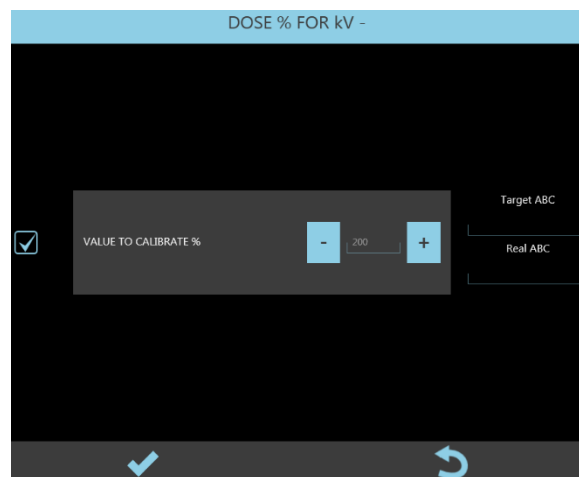

- 9) Set the noted kV value +2 kV and then give the X-ray command.
- 10) if the required kV value is reached slowly or fluctuates, adjust the value **DOSE % FOR kV-** :
 - Increase the value if the kV value is adjusted slowly,
 - Reduce the value if the kV value fluctuates.

11) Select **DOSE % FOR kV+**:

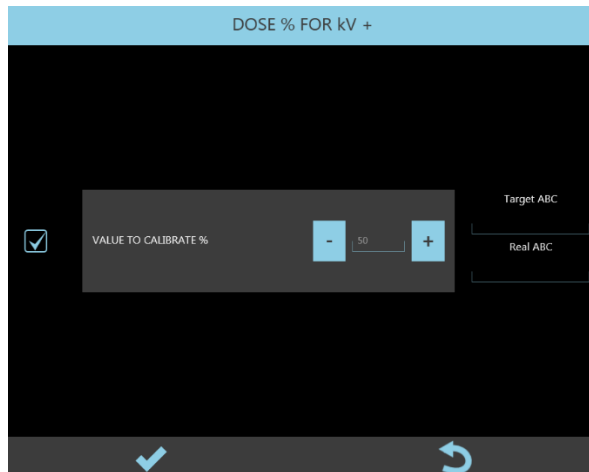

12) Set the noted kV value -2kV and then give the X-ray command.

13) If the required kV value is reached slowly or fluctuates, adjust the parameter **DOSE % FOR kV+**:

- Increase the value if the kV value is adjusted slowly,
- Reduce the value if the kV value fluctuates.

14) Select **DOSE % FOR kV--**:

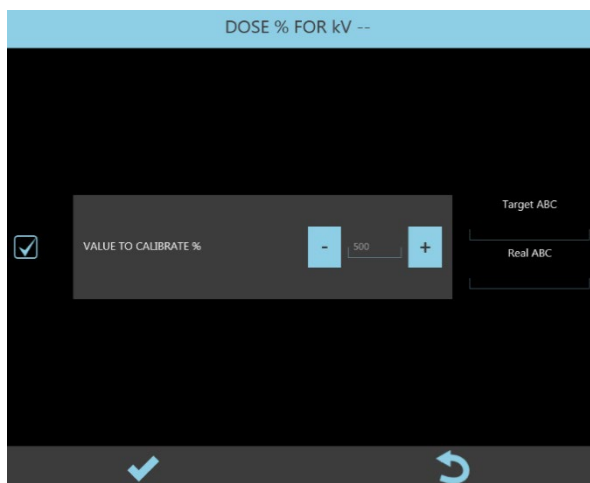

15) Set the noted kV value +5kV and then give the X-ray command.

16) If the required kV value is reached slowly or fluctuates, adjust the parameter **DOSE % FOR kV--**:

- Increase the value if the kV value is adjusted slowly,
- Reduce the value if the kV value fluctuates.

17) Select **DOSE % FOR kV++**:

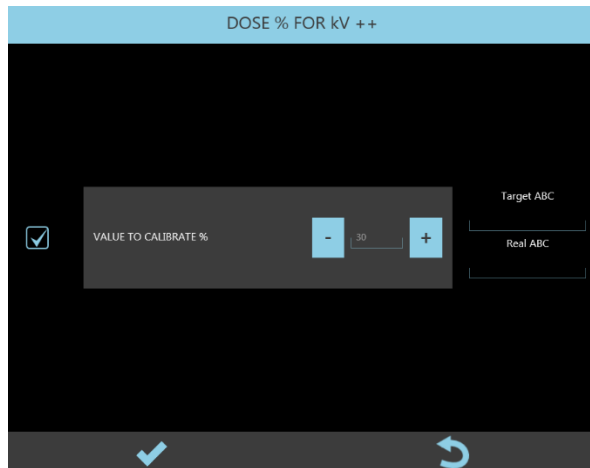

18) Set the noted kV value -5kV and then give the X-ray command.

19) If the required kV value is reached slowly or fluctuates, adjust the parameter **DOSE % FOR kV++**:

- Increase the value if the kV value is adjusted slowly,
- Reduce the value if the kV value fluctuates.

20) Select **DOSE % FOR kV---**:

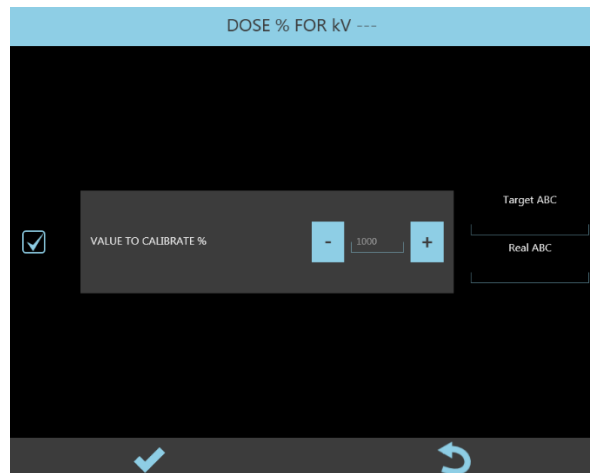

21) Set the noted kV value +10 kV and then give the X-ray command.

22) Adjust the **DOSE % FOR kV---** parameter if the required kV value is reached slowly or fluctuates:

- Increase the value if the kV value is adjusted slowly,
- Reduce the value if the kV value fluctuates.

23) Select **DOSE % FOR kV+++**, the following panel opens:

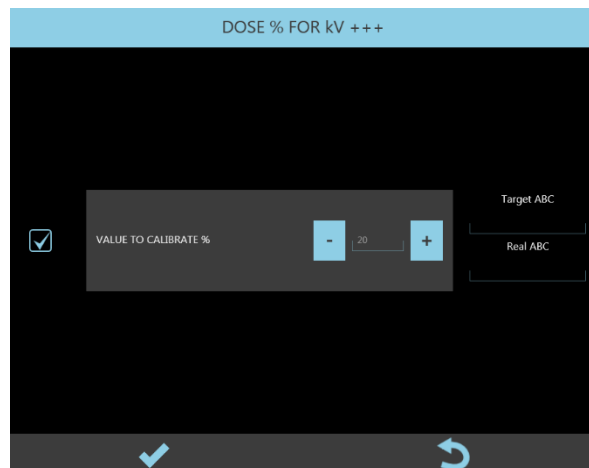

24) Set the noted kV value -10kV and then give the X-ray command.

25) Adjust the **DOSE % FOR kV+++** parameter if the required kV value is reached slowly or fluctuates:

- Increase the value if the kV value is adjusted slowly,
- Reduce the value if the kV value fluctuates.

2.1.5 CHECKING THE kV and mA

After adjusting the mA, you need to check the **kV** value and the **mA** directly on the X-ray generator inverter.

The kV precision tolerances foreseen by **standard EN 60601-2-54** are **±10%**.

If the kV value is not correct, check your earlier adjustments.

- Connect an oscilloscope to board S219 on the inverter:
 - channel 1: between Tp5 (+) and Tp2 (GND), to read the **kV** (REAL KV signal),
 - channel 2: between Tp8 (+) and Tp2 (GND), to read the **mA** (REAL mA signal),

The REAL KV signal at TP5 is negative (format: 1 V = -30 kV)

The format for the REAL mA signal at TP8 is:

- 1 V = 5 mA, if the mA set by the kV/mA curve are ≤ 10 mA, led DL23 OFF
- 1 V = 50 mA, if the mA set by the kV/mA curve are > 10 mA, led DL23 ON.

1) Checking the kV and mA in **Low Dose FLUOROSCOPY (CURVE 3)**

- Select the exam **DAILY TEST**.
- Select **Low Dose** fluoroscopy with Manual dose control.
- Set **60 kV** and acquisition rate: **15 fps**.
- Give the X-ray emission command and then read the kV and mA values on the oscilloscope.
- Repeat, this time setting **100 kV**.
- Check that the resulting values are correct respect values in the table below and then check the wave-length by comparing it to the typical wave-lengths shown in figures 4a (60 kV) and 4b (100 kV).

kV		mA		Pulse duration (in ms)	Wavelengths
Set	Accepted range	Set	Accepted range		
	In S219 (Tp5) [1V = -30kV]		In S219 (Tp8) [1V = 50mA]		
60	57 ÷ 63	5.5 mA	0.099 ÷ 0.121 V	33	Fig. 4a
100	95 ÷ 105	7.5 mA	0.135 ÷ 0.165 V	33	Fig. 4b

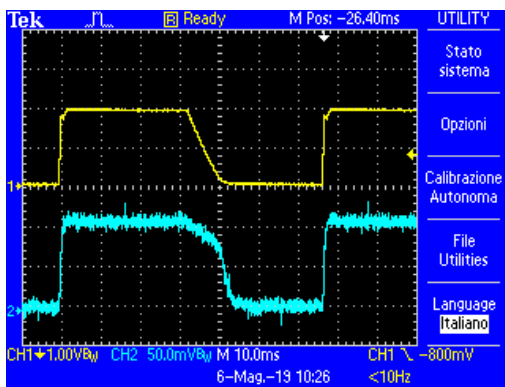

Fig. 4a

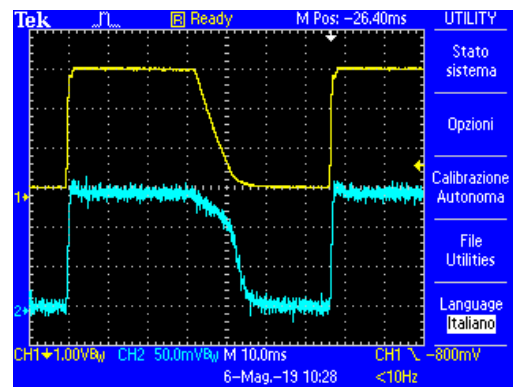

Fig. 4b

The mA value shown by the Control Panel for FLUOROSCOPY is the average mA value in a 1s exposure.

2) Checking the kV and mA in **High Quality FLUOROSCOPY** (CURVE 4)

- Select the exam **DAILY TEST**.
- Select **High Quality** fluoroscopy with Manual dose control.
- Set **60 kV** and acquisition rate: **15 fps**.
- Give the X-ray emission command and then read the kV and mA values on the oscilloscope.

- Repeat, this time setting **100 kV**.
- Check that the resulting values are correct respect values in the table below and then check the wave-length by comparing it to the typical wave-lengths shown in figures 5a (60 kV) and 5b (100 kV).

kV		mA		Pulse duration (in ms)	Wavelengths
Set	Accepted range	Set	Accepted range		
	In S219 (Tp5) [1V = -30kV]		In S219 (Tp8) [1V = 50mA]		
60	57 ÷ 63	22 mA	0.396 ÷ 0.484 V	20	Fig. 5a
100	95 ÷ 105	30 mA	0.540 ÷ 0.660 V	20	Fig. 5b

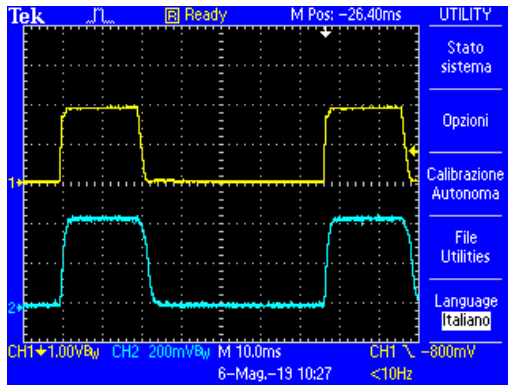

Fig. 5a

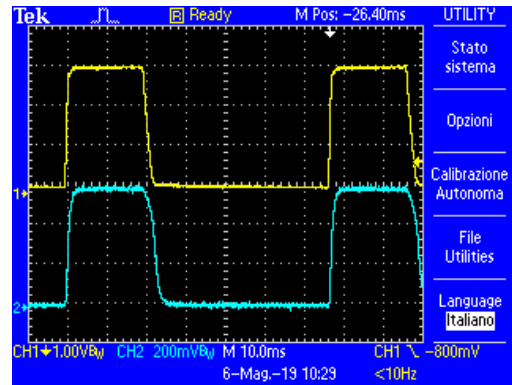

Fig. 5b

The mA value shown by the Control Panel for FLUOROSCOPY is the average mA value in a 1s exposure.

3) Checking the kV and mA in **RADIOGRAPHY** (CURVE 3)

- Select the exam DAILY TEST.
- Select Radiography mode.
- Set **60 kV - 8 mAs**.
- Give the X-ray emission command and then read the kV and mA values on the oscilloscope.

- Repeat, this time setting 100 kV - 8 mAs.
- Check that the resulting values are correct respect values in the table below and then check the wave-length by comparing it to the typical wave-lengths shown in figures 6a (60 kV) and 6b (100 kV).

kV		mA		Pulse duration (in ms)	Wavelengths
Set	Accepted range	Set	Accepted range		
	In S219 (Tp5) [1V = -30kV]		In S219 (Tp8) [1V = 50 mA]		
60	57 ÷ 63	46.6 mA	0.840 ÷ 1.025 V	170	Fig. 6a
100	95 ÷ 105	28.0 mA	0.504 ÷ 0.616 V	275	Fig. 6b

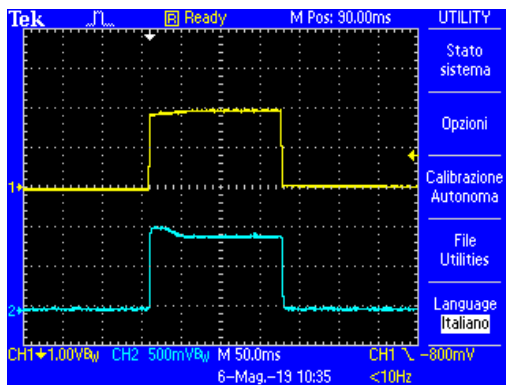

Fig. 6a

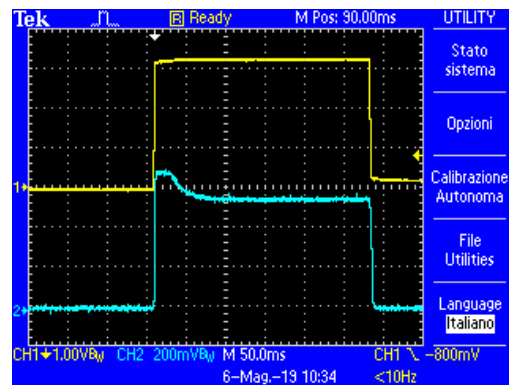

Fig. 6b

You also need to check that the set mAs value matches the product of the mA * Pulse duration for both kV values.

In this example:

- at 60kV: 47 mA * 0.170 s = 7.99 mAs
- at 100kV: 28 mA * 0.275 s = 7.7 mAs.

2.2 ADJUSTING THE X-RAY COLLIMATOR

The calibration procedure described below remains the same both with **FPD 2121** and **FPD 3030** version.

This procedure lets you set the following parameters:

- the correspondence between the actual aperture of the collimator and its "virtual" display on the LIH image,
- the max aperture (in mm) of the collimator squared iris for each detector field,
- the angle of correction between the actual and virtual positions on the monitor of the parallel shutters.

The calibration can be checked directly using the image of the collimators on the monitor, and so requires X-ray emission.

During calibration, the equipment automatically sets:

- the respective detector field for the current calibration,
- **Low Dose** fluoroscopy, Acquisition rate: **4 fps**.
- 40 kV.

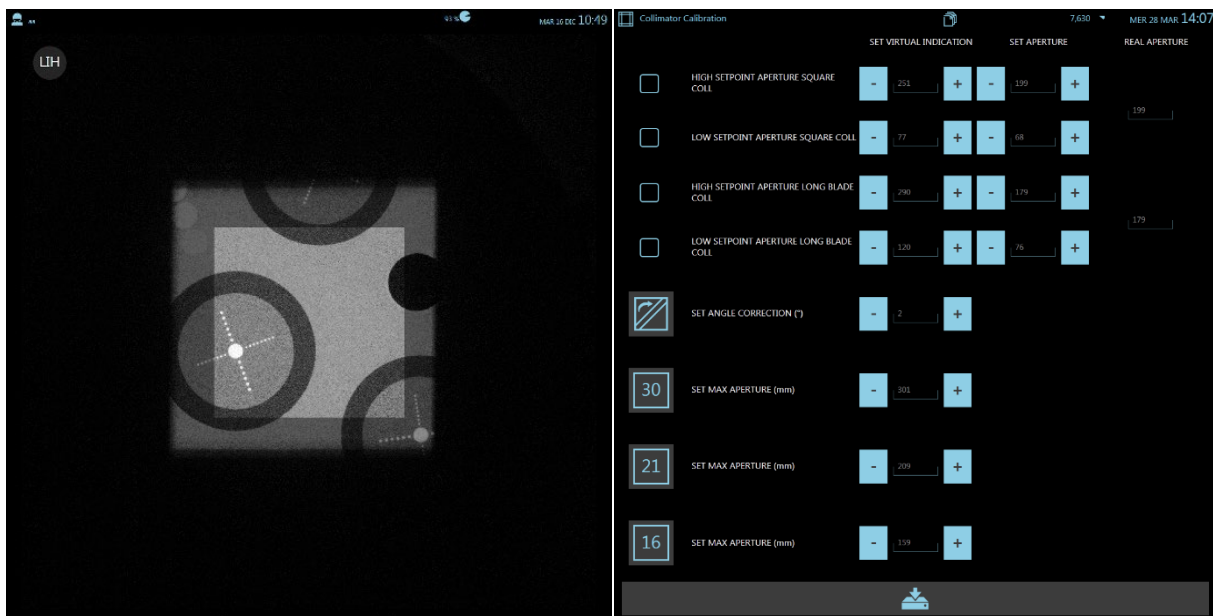

• **Adjusting the correspondence between the actual aperture and that shown on the monitor of the Square Field (Square Coll).**

- 1) Select the **High SetPoint Aperture Square Coll** parameter (the collimator positions itself to produce the size specified in the SET APERTURE field).

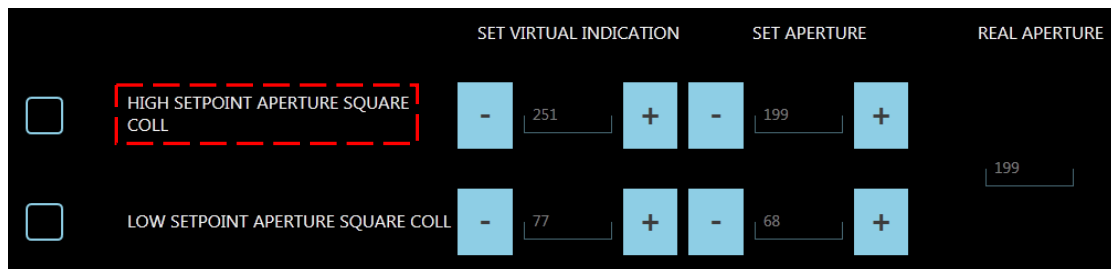

- 2) Give the X-ray emission command and adjust the **SET APERTURE** parameter so that the real collimator opens to cover about 1 cm from the edge of the image.
- 3) In stand-by, adjust the **SET VIRTUAL INDICATION** parameter ($120 \div 210$) so that the opening of the virtual collimators coincides with that of the actual collimators (see figure below).

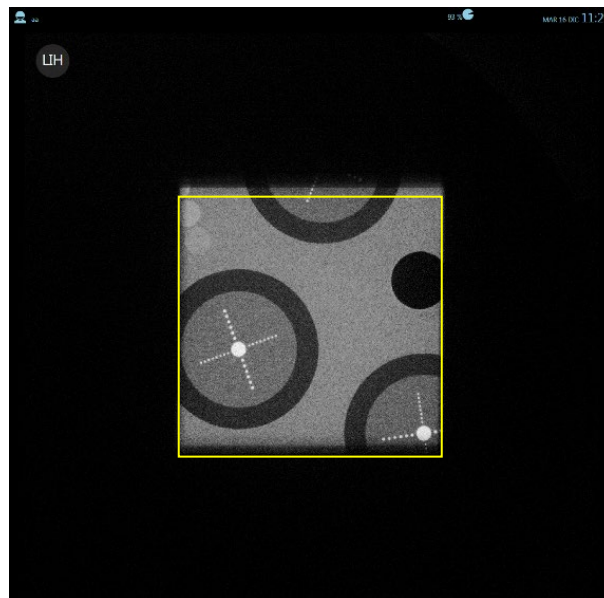

- 4) Select the **Low SetPoint Aperture** parameter (the collimator positions itself to produce the size specified in the SET APERTURE field).

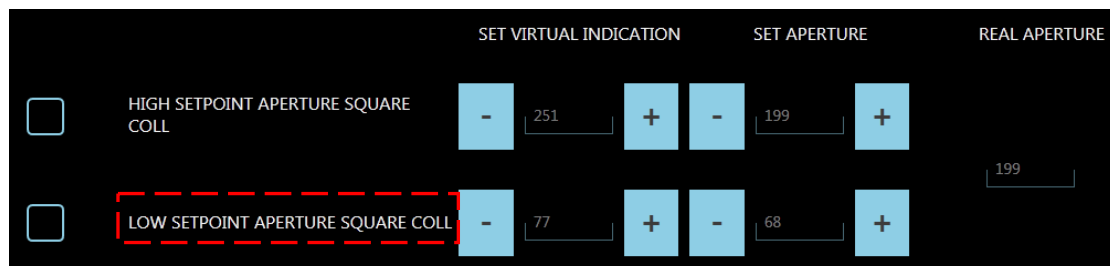

- 5) Give the X-ray emission command and adjust the SET APERTURE parameter so that the size of the actual collimator is about 1/4 that of the image (about 5 cm for FPD 2121 aSi, about 7,5cm for FPD 3030 aSi)
- 6) In stand-by, adjust the **SET VIRTUAL INDICATION** parameter ($0 \div 100$) so that the opening of the virtual collimators coincides with that of the actual collimators.

• **Adjusting the correspondence between the actual aperture and that shown on the monitor of the Shutters (Long Blade Coll).**

Carry out the regulation following the steps shown above for the Square Field.



• **Setting the max aperture of the collimator for each detector field**

Adjust the max aperture of the collimator (square iris) for each flat panel detector field.

FPD 3030	Field Size	Min (in mm)	Max (in mm)
30	300 x300 mm ²	270	320
21	210 x210 mm ²	180	230
16	160 x160 mm ²	130	180

FPD 2121	Field Size	Min (in mm)	Max (in mm)
21	210 x210 mm ²	180	230
16	160 x160 mm ²	130	180
12	120 x120 mm ²	90	140

- 1) Select the field you want to calibrate.
- 2) Give the X-ray emission command and adjust the corresponding aperture parameter so that the edges of the collimator are "slightly" visible inside the image.



Important: The adjustment of the max aperture for each detector zoom factor must be adjusted so that the edge of the collimator is still visible. This guarantees correct collimation of the X-ray beam.

• **Correcting the angle of rotation of the shutters**

You may need to correct misalignment between the angle of the shutters and their virtual display. To do this:

- 1) Select the parameter:



The square iris opens fully, whereas the shutters open by just 5 cm.

- 2) Give the X-ray emission command.
- 3) In standby, make sure that the angle of the virtual shutters matches that of the actual shutters; if necessary, adjust the parameter in question (-90 ... + 90).

- On completion of the calibration procedure, save the parameters by



touching this button:

2.2.1 CENTRING THE X-RAY COLLIMATOR

The collimator consists of two distinct elements:

- collimator with shutters,
- square iris collimator.

To center the collimator, you need to adjust the position of each element.

We recommend adjusting the position of the shutters **first** and **only then** that of the **square iris**.



X-ray emission is required in order to check the correct adjustment.
Protect yourself and move to a safe distance during this check.

2.2.1.1 CENTERING THE SHUTTERS

Centering involves checking the image of the shutters on the monitor.

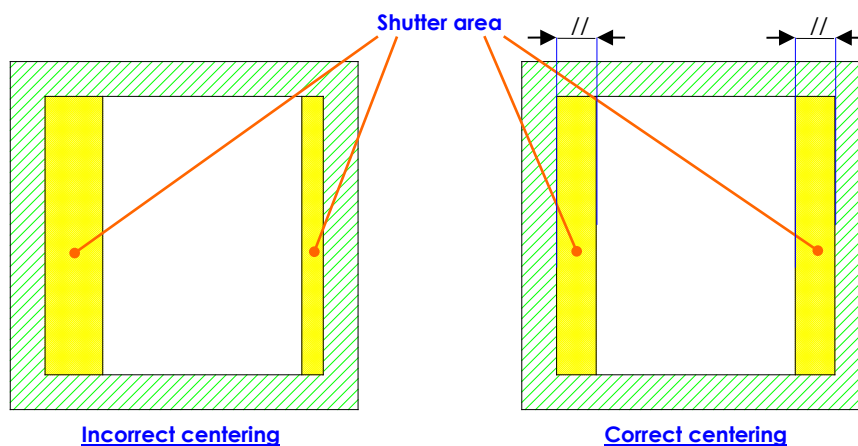

Fig.1

- Move the C-arm with the X-ray axis perfectly vertical and the monoblock lowered.
- Remove the top cover from the monoblock (see Paragraph 5.1.1 in Part 5 of this Manual).
- If present, remove dosimeter support, unscrewing its fixing screws near the collimator cover.
- Remove the cover from the collimator (see Paragraph 5.2.2.1 in Part 5 of this Manual).
- Select fluoroscopy with manual dose control and set 40 kV.
- Select Flat Panel detector nominal field and open the squared iris fully.
- With X-ray emission, rotate the shutters until you can see them in vertical position on the screen and then adjust their aperture so that they appear about 2 cm from the edges of the image.
- If not properly centered, loosen the 3 rods "A" (Fig. 2a and 2b), shifting this unit as required.
- Once centered vertically, rotate the shutters until they are horizontal and then give the X-ray emission command. If needed, move the shutter unit as required to get the best compromise between the vertical and the horizontal position.

- Then fix the shutter unit in position by tightening the 3 rods "A".

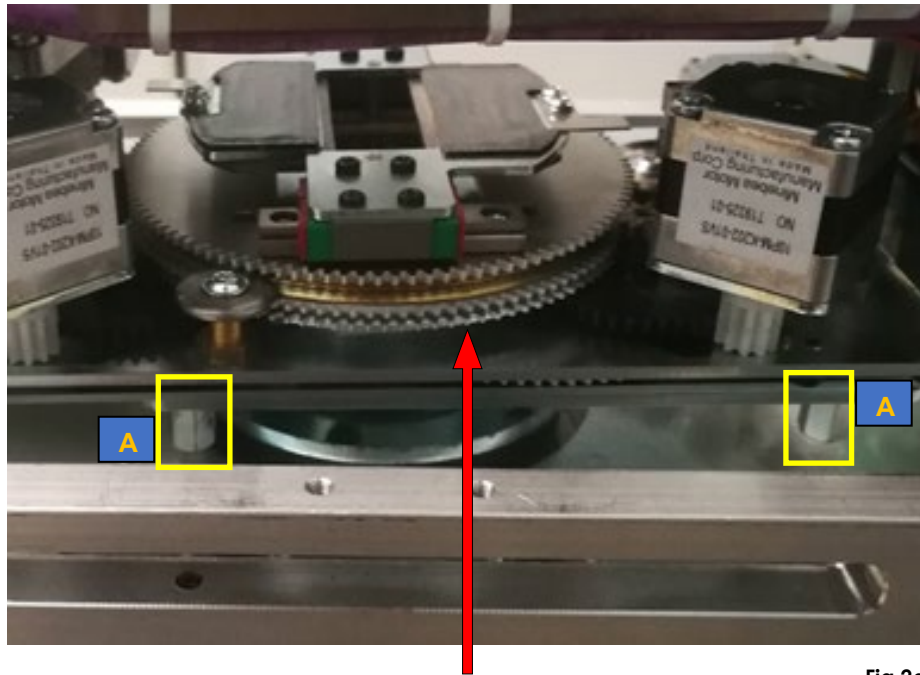

Fig.2a

Note: The specific split makes the centering procedure easier

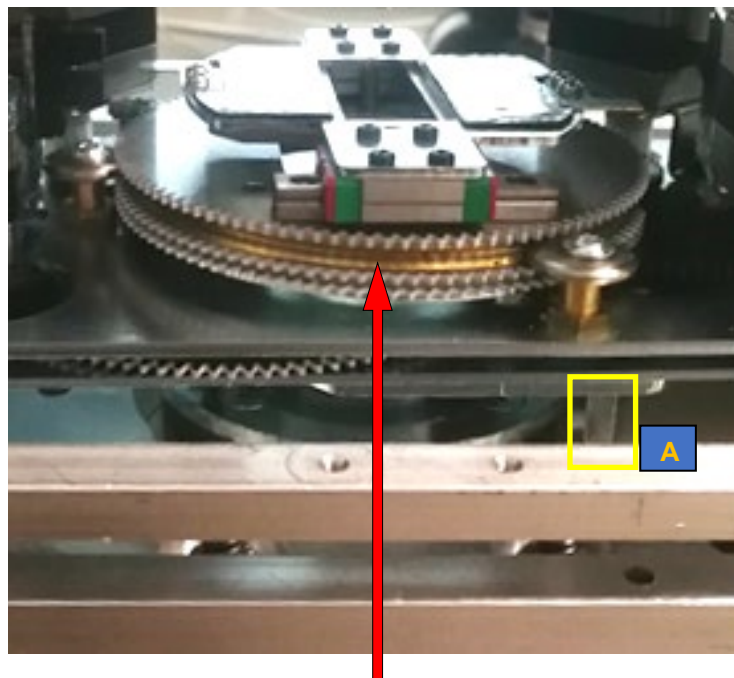
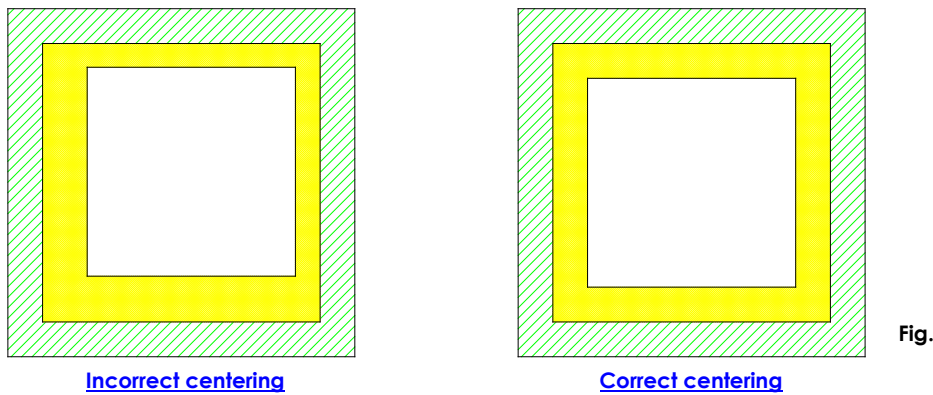

Fig.2b

Note: The figure shows the collimator without its cover and without the DAP supports.

2.2.1.2 CENTRING THE SQUARE FIELD

The square iris should only be centered **after** centering the shutters. Centering involves checking the image on the monitor.



With the same working conditions used to center the shutters:

- Open the square iris fully,
- With X-ray emission, set an aperture in the square field so that the square iris is visible within the image (both horizontally and vertically).
- If not properly centered, loosen the 3 rods "B" (Fig. 4) used to secure the unit in position and then shift this as required.
- Check the centering for all the detector fields.
- Once properly centered, fix the position of the square field group by tightening the 3 screws "B".

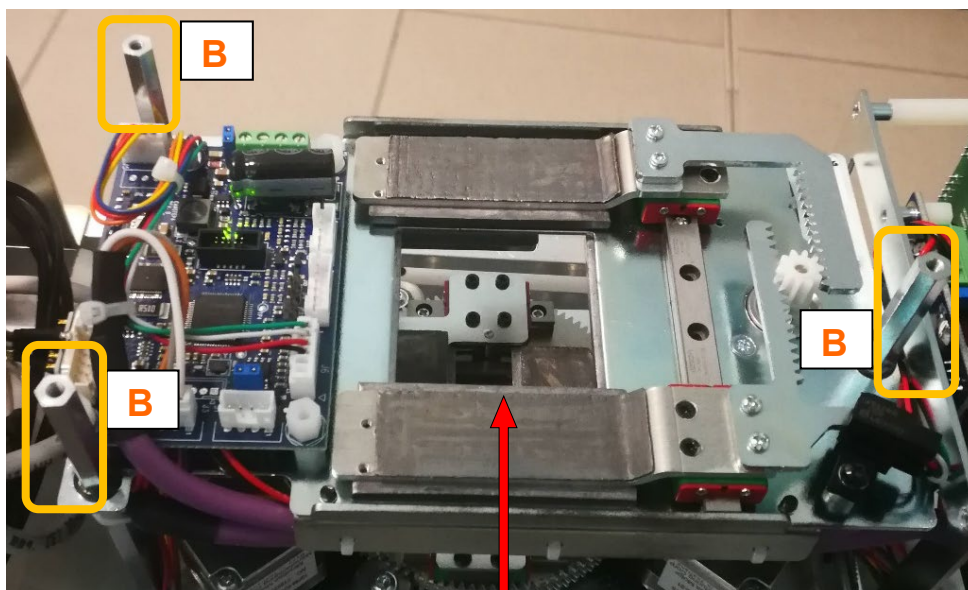

Square Field Unit

Fig.4

Note: The figure shows the collimator without its cover and without the DAP supports.

2.3 ADJUSTING THE LASER BEAM CENTRING DEVICES

In order to center the X-ray beam, the equipment uses 2 x class 1M laser beam centering devices (optional) placed on the X-ray monoblock and 2 x class 1M laser beam centering devices (optional) placed on the Flat Panel detector.

The two laser modules placed on the monoblock have the same position both on the FPD 2121 Asi version, and on the FPD 3030 Asi one; the laser modules placed on the flat panel have different positions, instead.

The resulting differences during a regulation procedure are explained in paragraph 2.3.2 below ("Adjusting the laser centering devices on the FPD").

2.3.1 ADJUSTING THE LASER CENTRING DEVICES ON THE MONOBLOCK

The two laser modules are housed in a dedicated support; to adjust their centering, it is required to remove the upper monoblock cover. (See Sec. 5, paragraph 5.1.1).

In order to check the centering, switch on the laser beams using the relevant key on the control panel.

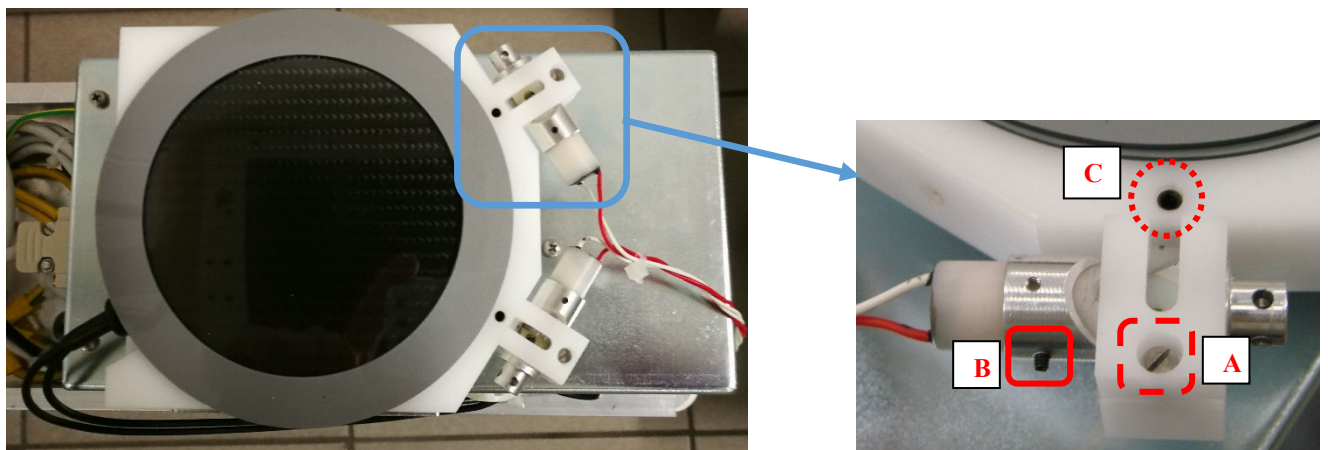

Note: the equipment shown in figure is provided with a DAP device (optional).

The laser projection now appears on the FPD cover, where you can find four landmarks to easier accomplish the procedure (see the figure below).

Place your C-arm vertically, with the monoblock downward.

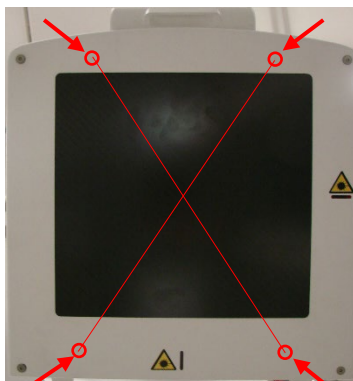

Operate on the laser module clamping points to carry out the centering procedure:

- loosening the **screw A**, you can move the metallic support, centering the laser beam with the relevant exit of its plastic support,
- loosening the **grub screw B**, you can adjust the laser beam grade, rotating only the laser module in its metallic support;
- loosening the **grub screw C**, you can tilt the whole plastic support, to shift the laser beam on the right or on the left.

If required, repeat the same procedure with the second device.

2.3.2 ADJUSTING THE LASER CENTRING DEVICES ON THE FPD

The laser modules position, on the FPD, is different depending on the detector versions
 With detector FPD 2121 Asi or FPD 3030 Asi.
 On the FPD cover, the points where the laser modules lay, are marked with this symbol:



This is the centering procedure to follow for the **FPD 2121 Asi** version.

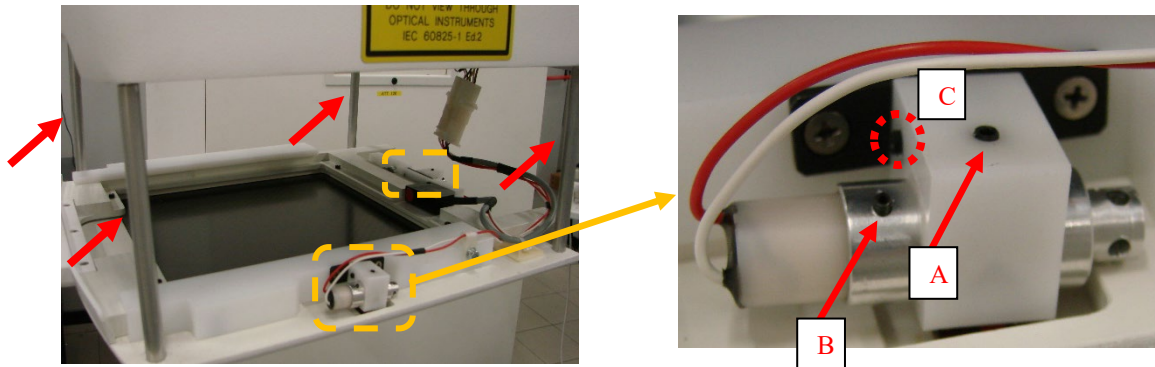

To reach the laser modules, it is required to remove the FPD cover (see Paragraph 5.3.2, Part 5 of this Manual). Laser devices are fixed rear the panel.
 To make the calibration procedure more comfortable, the equipment is provided with four cylinder-shaped poles (pointed at in figure with a red arrow), that work as spacers between the cover panel and the FPD group.

Insert the poles between the panel and the FPD, as shown in the figure.
 In order to check the laser beam centering, turn on the laser beams using the relevant key on the control panel; a cross projection now appears on the monoblock (shown in the figure below).



To adjust the laser devices centering, follow the same procedure as in the previous paragraph (operating on the clamping points **A**, **B**, and **C**).



With **FPD 3030 Asi** version, follow the same procedure described above; the only difference is that the modules make a X-shaped projection with a grade of 30° between the beams, as shown in the figure aside.



2.4 ADJUSTING THE UP/DOWN COLUMN MOVEMENT

The motorized movement of the stand column lets you adjust the up/down speed of the column and limit the maximum motor current.

There are 3 potentiometers on board B2 (ASAC) used for these adjustments (see Fig.5). You need to check these adjustments should this board be replaced.

Potentiometer	Name	Function
P1	UP SPEED	Adjustment of the speed of the upwards movement.
P3	DOWN SPEED	Adjustment of the speed of the downwards movement.
P2	CURRENT LIMITATION	Adjustment of the max motor current

- First adjust:
 - potentiometer **P2** (CURRENT LIMITATION), by turning this as far clockwise as it can go to disable all current limitation,
 - potentiometers **P1** (UP SPEED) and **P3** (DOWN SPEED), by turning these as far clockwise as they can go (min speed).
- Adjust potentiometer **P1** so that the UP speed of the column is roughly 1 cm/s (the column takes at least 45 seconds to reach to its max height).
- Adjust potentiometer **P3** so that the DOWN speed of the column is roughly 1 cm/s (the column takes at least 45 seconds to reach to its min height).

You need to adjust the max motor current (and thus the max motor force) at its minimum setting to ensure upwards movement to guarantee safe movement in the event of the column unit accidentally hitting any external elements.

- With the longitudinal trolley of the C-arm (200 mm) fully forwards, adjust potentiometer **P2** to get the min current value that still ensures smooth upwards movement.

Note: The motor absorbs more current as it reaches its upper limit switch.

Typical motor current values:

- UP: 5 A max
- DOWN: 1 A max

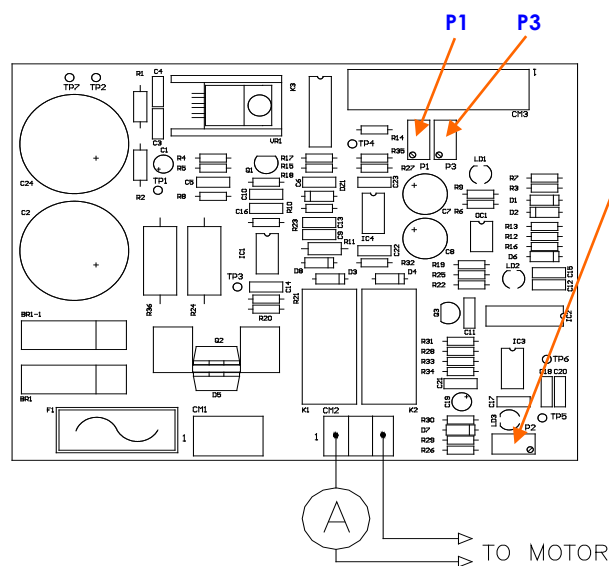

Fig.5
B2 board

3 DETECTOR CALIBRATION

3.1 INTRODUCTION

The detector is calibrated in the factory.

In the following, the detector needs to be re-calibrated at least every 6 months.

Calibration lets you update the **Gain** and **Defect Map** parameters associated to each detector pixel and find any defective (bad) pixels.

It is necessary to calibrate the acquisition modes of the detector used by the equipment according to following tables.

DETECTOR PaxScan 3030DXV				
FLUOROSCOPY				
Detector mode	Field (cm ²)	fps	X-ray window (ms)	Nominal Sensitivity (lsb/nGy)
Mode 2	30x30 (binning 2x2)	15	33	54
Mode 0	30x30 (binning 1x1)	8	33	27
Mode 4	21x21	15	33	27
RADIOGRAPHY				
Detector mode	Field (cm ²)	fps	X-ray window (ms)	Nominal Sensitivity (lsb/nGy)
Mode 1	30x30	1	967	1.8

DETECTOR PaxScan 2121DXV				
FLUOROSCOPY				
Detector mode	Field (cm ²)	fps	X-ray window (ms)	Nominal Sensitivity (lsb/nGy)
Mode 0	21x21	15	33	27
RADIOGRAPHY				
Detector mode	Field (cm ²)	fps	X-ray window (ms)	Nominal Sensitivity (lsb/nGy)
Mode 1	21x21	1	967	1.8

For each *detector mode*, the calibration requires the acquisition of a series of images at an intermediate level within the range of 17000 - 24000 lsb.

The number of images acquired during calibration is:

- 32 images for modes at 15 fps,
- 16 images for modes at 7.5 fps,
- 8 images for radiography modes

The detector software uses these images to create the **Gain** map and the **Defect Map** needed to generate correct images (clean images).

Exposures must be performed:

- with the same X-ray beam filtering conditions,
- without anti-scattering grid,
- with the collimator fully open in order to irradiate all areas of the detector,
- after the equipment has been switched on for at least 1 hour.

These conditions are absolutely necessary in order to ensure the calibration procedure is performed correctly.

The exposure parameters have to be chosen such as to generate detector image levels within the specified range (17000 - 24000 lsb).

If this is not the case, the calibration might fail or not be reliable.

Therefore, before carrying out the calibration procedure, it is necessary to determinate the correct exposure values as it is described in the following paragraph 3.2.

3.2 FINDING THE EXPOSURE VALUES FOR CALIBRATION

You need to know the radiological parameters needed to expose the detector correctly at the required doses before starting the calibration procedure.

These parameters must be set during the calibration procedure.

Below are the X-ray emission conditions defined at the factory.

DETECTOR PaxScan 3030DXV							
FLUOROSCOPY							
Field	kV	Filament Curve	mA	Collimator filter	Grid	Additional filter	LSB level
Mode 2 30x30 Binning 2x2 (15 fps)	58	Pulsed Curve 3: LF 0.4-10 mA	4.6	No	Absent	10 mm Al	8500 ÷ 12000
Mode 0 30x30 Binning 1x1 (8 fps)	63	Pulsed Curve 3: LF 0.4-10 mA	7.0	No	Absent	10 mm Al	17000 ÷ 24000
Mode 4 21x21 (15 fps)	63	Pulsed Curve 3: LF 0.4-10 mA	7.0	No	Absent	10 mm Al	17000 ÷ 24000
RADIOGRAPHY							
Field	kV	Filament Curve	mAs	Collimator filter	Grid	Additional filter	LSB level
Mode 1 30x30	70	Rad Curve 3: LF 100kV-28mA	8	No	Absent	21 mm Al	17000 ÷ 24000

DETECTOR PaxScan 2121DXV							
FLUOROSCOPY							
	kV	Filament Curve	mA	Collimator filter	Grid	Additional filter	LSB level
Mode 0 21x21 (15 fps)	63	Pulsed Curve 3: LF 0.4-10 mA	7.0	No	Absent	10 mm Al	19300 typ. (17000 ÷ 24000)
RADIOGRAPHY							
Field	kV	Filament Curve	mAs	Collimator filter	Grid	Additional filter	LSB level
Mode 1 21x21	70	Rad Curve 3: LF 100kV-28mA	8	No	Absent	21 mm Al	21700 typ. 17000 ÷ 24000

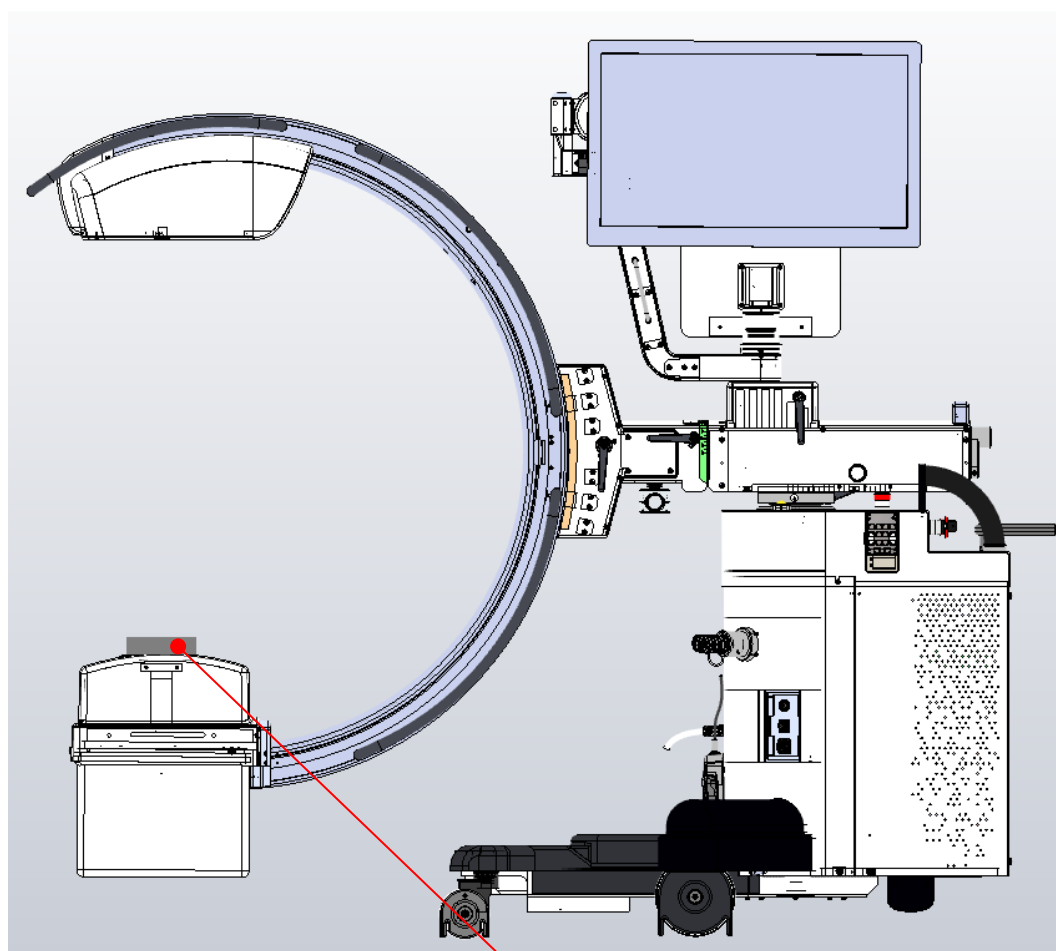

Aluminum additional filter

3.3 CALIBRATION PROCEDURE

Log in as **Administrator** to access the calibration menu.

It is possible to calibrate a single acquisition mode or even all modes during one session only.

3.3.1 FLUOROSCOPY CALIBRATION OF DETECTOR 3030

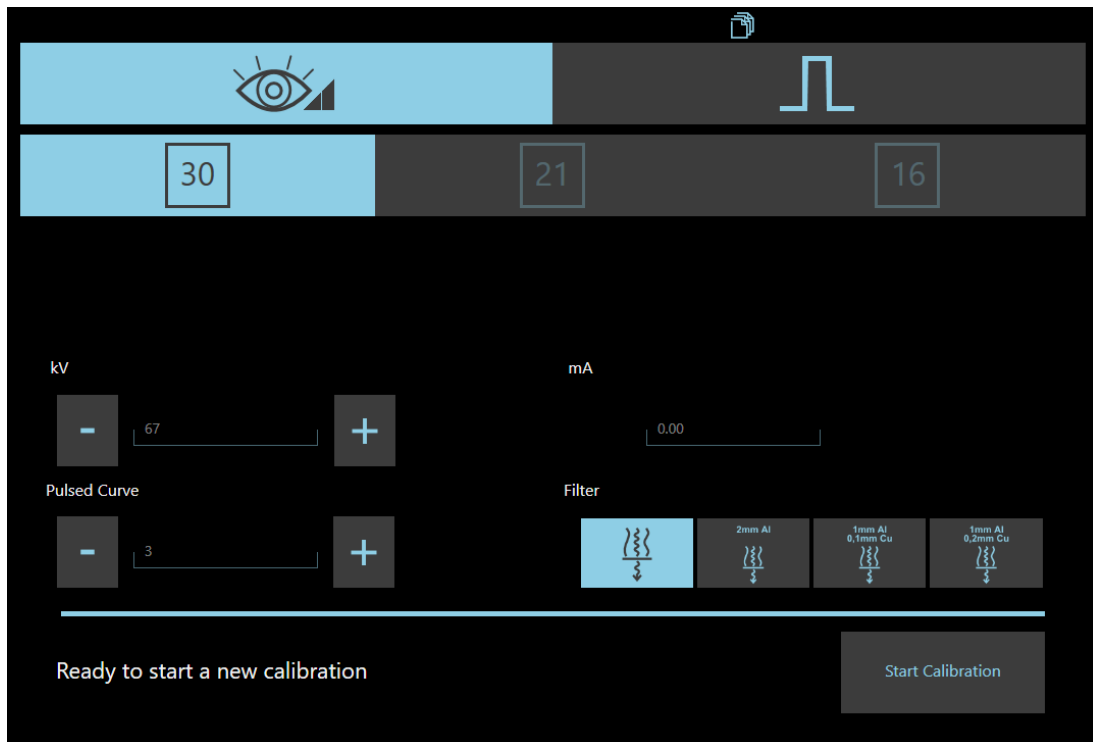

Below you will find a description of the calibration for fluoroscopy configuration with 30x30 detector:

- 1) When the calibration menu is opened, the system automatically calibrates the offset (**Dark Calibration**) for all configurations, if necessary.
- 2) Select **fluoroscopy** and field 30.
- 3) Touch the **Start a new calibration** key.
- 4) The procedure displays the message "**Calibration of mode m2b2 at 15 fps**" as well as the request "**Set dose to: range 17000 – 24000 image levels**"
- 5) Set the kV values required for the current acquisition mode.
- 6) Touch "**Continue**" (lower button).
- 7) The procedure now asks you to "**Start X-Ray**".
- 8) Press the X-ray emission command button within 15 seconds and keep it pressed until you are asked to "**Stop X-ray**".
- 9) Touch "**Continue**" (lower button).
- 10) The procedure displays the message "**Calibration of mode m0b1 at 8 fps**" as well as the request "**Set dose to: range 17000 – 24000 image levels**"
- 11) Repeat the procedure from point 5 until 9
- 12) The system will display the successful fluoroscopy calibration procedure on field 30
- 13) Select field 21
- 14) Touch the **Start a new calibration** key.
- 15) The procedure displays the message "**Calibration of mode m4b1 at 15 fps**" as well as the request "**Set dose to: range 17000 – 24000 image levels**"
- 16) Repeat the procedure from point 5 until 9
- 17) The system will display the successful fluoroscopy calibration procedure on field 21

3.3.2 FLUOROSCOPY CALIBRATION OF DETECTOR 21x21

Below you will find a description of the calibration for fluoroscopy configuration with 21x21 detector:

- 1) When the calibration menu is opened, the system automatically calibrates the offset (**Dark Calibration**) for all configurations, if necessary.
- 2) Select Fluoroscopy and field 21x21.
- 3) Touch the **Start a new calibration** key.
- 4) The procedure displays the message "**Calibration of mode m0b1 at 15 fps**" as well as the request "**Set dose to: range 17000 – 24000 image levels**"
- 5) Set the kV values required for the current acquisition mode.
- 6) Touch "**Continue**" (lower button).
- 7) The procedure now asks you to "**Start X-Ray**".
- 8) Press the X-ray emission command button within 15 seconds and keep it pressed until you are asked to "**Stop X-ray**".
- 9) Touch "**Continue**" (lower button).
- 10) The system will display the successful fluoroscopy calibration procedure

3.3.3 RADIOGRAPHY CALIBRATION

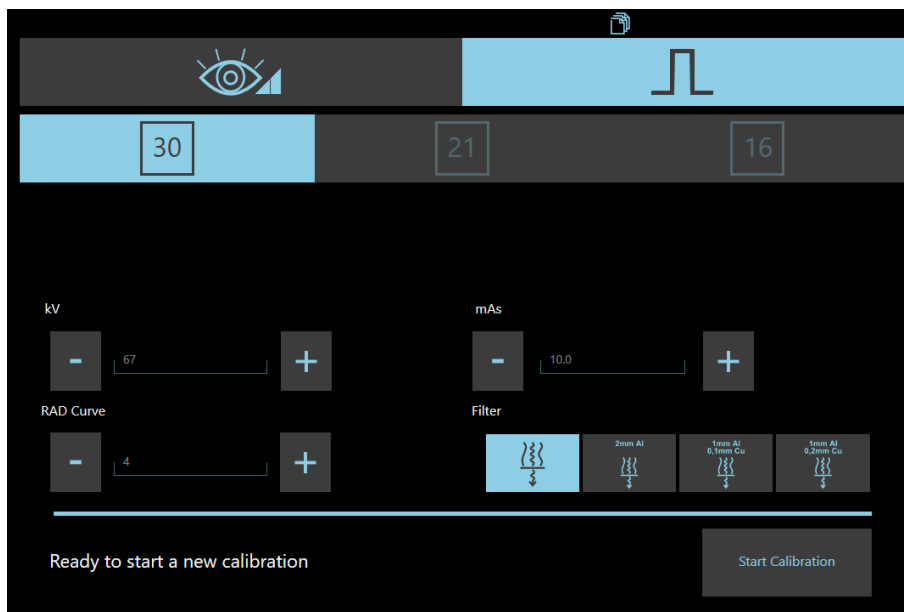

Below you will find a full description of the radiography calibration in configuration with 30x30 detector (the same procedure applies to 21x21 FPD).

- 1) When the calibration menu is opened, the system automatically calibrates the offset (**Dark Calibration**) for all configurations, if necessary.
- 2) Select **Radiography** mode (with this acquisition mode, only FPD nominal field is available).
- 3) Touch the key **Start a new calibration**.
- 4) The procedure displays the message "**Calibration of mode m1b1 at 1 fps**" as well as the request "**Set dose to: range 17000 – 24000 image levels**"
- 5) Set the kV values required for the current acquisition mode.
- 6) Touch "**Continue**" (lower button).
- 7) The procedure now asks you to "**Start X-Ray**".
- 8) Press the X-ray emission command button within 15 seconds and keep it pressed until you are asked to "**Stop X-ray**".
- 9) Touch "**Continue**" (lower button).
- 10) The system will display the successful radiography calibration procedure

4 ANNEXES

4.1 POTENTIOMETER LIST

POSITION	NAME	VALUE	DESCRIPTION	NOTES
B4 (BOARD ASAC 01)	P1	10K	UP SPEED	
	P2	2K	CURRENT LIMITATION	
	P3	10K	DOWN SPEED	
BOARD S83 (X-Ray tube)	P1	20K		Fixed adjustment: <u>do not touch</u>
	P2	20K		
	P3	20K		
	P4	20K		
Relay	K1 K2	80.01.0.240.0000	Timed relay switch	Set at 4s

4.2 LED LIST

POSITION	NAME	VALUE	DESCRIPTION	NOTES
B1 (BOARD CTBK-HW 00)	LD1	Orange	N.U.	
	LD2	Green	Power ON for DOOR security check circuit	
	LD3	Blue	RS-232 activity (CTBK RS232 transmit)	
	LD4	Blue	RS-232 activity (CTBK RS232 receive)	
	LD5	Blue	N.U.	
	LD6	Blue	N.U.	
	LD7	Blue	DAP readout	
	LD8	Blue	N.U.	
	LD9	Blue	N.U.	
	LD10	Green	+5V for Analog out circuit	
	LD11	Green	+12V for Analog out circuit	
	LD12	Orange	Injector running	
	LD13	Orange	Booster OK	
	LD14	Orange	Injector is available and ready	
	LD15	Yellow	Enable Booster capacitor charge output	
	LD16	Yellow	Injector start relay	
	LD17	Yellow	Injector start output	
	LD18	Yellow	Injector enable start output	
	LD19	Yellow	Injector inhibit relay	
	LD20	Orange	Motor UP command input	
	LD21	Yellow	Injector inhibit output	
	LD22	Orange	Motor DOWN command input	
	LD23	Yellow	Motor UP output	
	LD24	Yellow	Motor DOWN output	
	LD25	Yellow	Injector stop relay	
	LD26	Yellow	Injector stop output	
	LD27	Yellow	Security motor UP/DOWN command (from uP)	
	LD28	Yellow	Pre X-Ray output	
	LD29	Yellow	Inverter Supply output	
	LD30	Orange	Rad preparation input	
	LD31	Orange	Rad command input	
	LD32	Orange	Enable Hand switch input	
	LD33	Orange	Footswitch LEFT input	
	LD34	Yellow	Enable X-Ray generator output	
	LD35	Yellow	X-Ray generator RX command	
	LD36	Yellow	Spare	
	LD37	Yellow	Spare	
	LD38	Orange	Footswitch RIGHT input	
	LD39	Orange	Footswitch One shot input	
	LD40	Orange	X-Ray generator Exposure ok input	
	LD41	Orange	Enable X-Ray command switch(J27)	
	LD42	Orange	Spare	

POSITION	NAME	VALUE	DESCRIPTION	NOTES
	LD43	Orange	X-Ray command switches COMMON REQUEST	
	LD44	Orange	Spare	
	LD45	Orange	Grid present input	
	LD46	Green	Power ON (C-Arm)	
	LD47	Yellow	X-Ray lamp 1 (trolley lamp) output	
	LD48	Yellow	X-Ray lamp 2 (C-Arm lamp) output	
	LD49	Green	Power ON (trolley)	
	LD50	Orange	InfraRed data input	
	LD51	Yellow	Detector FREQ signal output	
	LD52	Yellow	Detector Valid X-Ray signal output	
	LD53	Yellow	Spare	
	LD54	Yellow	Spare	
	LD55	Orange	Detector X-Ray Enable input	
	LD56	Orange	Spare	
	LD57	Orange	Spare	
	LD58	Green	Power ON for logic circuit	
	LD59	Green	Power ON for microprocessor circuit	
	LD60	Green	Power ON for RS-232, Detector interface and IR communication circuit	
	LD61	Green	Power ON 24V main supply	
	LD62	Green	Power ON for Can-Bus communication circuit	
	LD63	Green	Watch Dog is ON	
	LD64	Red	Watch Dog fault	
	LD65	Green	Laser Supply ON	
	LD66	Yellow	Enable Laser ON output	
	LD67	Yellow	Laser ON output	
	LD68	Orange	DAP pulses input	
	LD69	Orange	Door closed input	
	LD70	Yellow	Light room output	
B4 (BOARD ASAC O1)	LD1	Green	MOTOR COMMAND	
	LD2	Green	MOTOR RUNNING	
	LD3	Red	OVER CURRENT LIMITATION	
B22 (BOARD IRT 00)	LD1	Green	InfraRed ON	
BOARD S219	DL 1		Power on 24V	
	DL 2		COM FAULT	
	DL 3		COM OK	
	DL 4		Δ kV MAX	
	DL 5		kV>110%	
	DL 6		kV min	
	DL 7		mA Rx max	
	DL 8		COM RX HW	
	DL 9		kV>85%	
	DL 10		COM Rx	
	DL 11		ON Inverter	
	DL 12		PWM COM "B"	
	DL 13		PWM COM "A"	
	DL 14		Pre Rx	
	DL 15		N.U.	
	DL 16		Starter ok	
	DL 17		Starter Rad	
	DL 18		Starter Fluoro	
	DL 19		N.U.	
	DL 20		Filament Fault	
	DL 21		Filament Ok	
	DL 22		Small Filament	
	DL 23		Indication of the kV/mA signal format on test point TP8. (1V=10mA led OFF 1V=100mA led ON)	

4.3 FUSE LIST

POSITION	NAME	VALUE	DESCRIPTION	NOTES
TB2 (Stand)	F1	250 mAT	MAIN SUPPLY	
	F2	2,5AT	GENERAL SUPPLY	
	F3	2,5AT	GENERAL SUPPLY	
	F4	20 AT	GENERATOR SUPPLY	
	F5	20 AT	GENERATOR SUPPLY	
B1 (BOARD CTBK-HW)	F1	2,5AT	GENERAL SUPPLY	
B4 (BOARD ASAC 01)	F1	10 AT	+26 Vac	

Part 5: MAINTENANCE

CONTENTS

	pages	rev.	Date
CONTENTS	1.1 – 1-2	A	21/03/22
1 ROUTINE MAINTENANCE	1.1 - 1.1	0	01/03/21
1.1	General recommendations		
1.2	Daily/weekly checks and inspections		
1.3	Cleaning and disinfecting		
1.4	Six-monthly checks and inspections		
2 EXTRAORDINARY MAINTENANCE	2.1 - 2.20	0	01/03/21
2.1	Troubleshooting		
2.2	Replacing components		
2.3	Restoring the video processor system hard disk		
2.4	Software upgrades		
2.4.1	Upgrading the Main Controller software (CBTK-HW)		
2.4.2	Updating the SYSTEMA DRF-S software		
2.5	Adjusting the monitor		
3 SPARE-PARTS	3.1 - 3.2	0	01/03/21
3.1	List of spare-parts		
4 SCRAPPING	4.1	0	01/03/21
4.1	Procedures and precautions		
5 FITTING/REMOVING COMPONENTS	5.1 - 5.26	0	01/03/21
5.1	Fitting / removing the covers		
5.1.1	X-ray monoblock cover		
5.1.2	Flat panel detector (FPD) cover		
5.1.3	Stand cover		
5.2	Fitting / removing the X-ray monoblock unit components		
5.2.1	X-ray monoblock		
5.2.2	X-ray collimator unit		
5.2.2.1	X-ray collimator		
5.2.2.2	Dose Area Product meter (DAP)(optional)		
5.3	Fitting / removing the Flat panel detector (FPD) components		
5.3.1	FPD		
5.3.2	Laser / anti scattered grid unit		
5.4	Fitting / removing the stand components		
5.4.1	Parking brakes		
5.4.2	Stand wheel rotation chains		
5.4.3	Adjusting the C-arm bearings		
5.4.4	Replacing the video processor		
5.4.5	Replacing boards CTBK-HW and ASAC 01		

- 5.4.6 Replacing the control panel (PC panel)
- 5.4.7 Replacing the inverter
- 5.4.8 Replacing the main power cable

6 ANNEXES

6.1 - 6.23

A 21/03/22

- 6.1 Creating a back-up disk for the video processor
- 6.2 Contrast medium injector interface
 - 6.2.1 Creating the injector interface
 - 6.2.2 Injector Setup
- 6.3 Exporting - importing images
- 6.4 Exporting - importing exams
- 6.5 Replacing the battery backup on the mother board

1 **ROUTINE MAINTENANCE**

1.1 **GENERAL RECOMMENDATIONS**

See the instructions in the User Manual (see Paragraph 5.1.1 in Part 2).

1.2 **DAILY/WEEKLY CHECKS AND INSPECTIONS**

See the instructions in the User Manual (see Paragraph 5.1.2 in Part 2).

1.3 **CLEANING AND DISINFECTING**

See the instructions in the User Manual (see Paragraph 5.2 in Part 2).

1.4 **SIX-MONTHLY CHECKS AND INSPECTIONS**

Carry out the complete Acceptance Test procedure once every 6 months or, in any case, in line with current safety regulations.

Make a note of the results on the TEST SHEET (see Paragraph 1.5 in Part 3 of this Manual), together with details of any action taken.

For a better feasibility, a copy of the TEST SHEET has been included at the end of the present manual.

2 **EXTRAORDINARY MAINTENANCE**

2.1 **TROUBLESHOOTING**

In order to facilitate the troubleshooting, the tables below give indications of the most common malfunctions plus their most probable causes.

Nr.	PROBLEM FOUND	PROBABLE CAUSE	RECOMMENDED ACTION
1	No stand commands work.	No power supply at stand input.	Check to see if the magnetothermal switch has tripped: reset if necessary. Check to see if the emergency buttons on the monitor unit and stand have been used: reset if necessary. Check for voltage at terminal board TB2 -1.2 of the stand. Check for voltage at terminal board TB2 -7.8 of the stand.
2	Stand comes on, but the control panel is 'dead'.	Control panel power unit faulty.	Check fuses F2 and F3 on terminal board TB2.
3	Equipment works, but there is no X-ray emission. No alarm on the control panel.	X-ray emission footswitch or handswitch faulty.	Check the footswitch cable and connector. Check the X-ray emission button cable.
4	Monitor blank.	- Monitor faulty. - Incorrect brightness and contrast adjustment. - Video processor faulty.	Check position of the ON/OFF switch. Contact the technical service for recalibration or replacement of the monitor.
5	The control panel reads: CTBK +24V SUPPLY FAULT	Problem with power circuits on boards or fuses have blown: VR3 power circuit faulty.	Replace board.
6	The control panel reads: FILAMENT FAULT	X-ray generator filament board faulty.	Replace the X-Ray generator.
		X-ray tube filament broken.	Replace the monoblock.
		X-ray generator power circuits faulty.	Check fuses F4 and F5 on terminal board TB2.
7	The control panel reads: X-RAY GENERATOR FAULT	Check alarm LED on X-ray generator board S219.	Call Technical Service.
8	The stand reads: kV MAX	The X-ray generator has detected too much voltage at the X-ray tube during exposure.	Check the mains voltage feeding the X-ray generator. Check whether the problem also occurs at low kV.
9	The control panel reads: MAX FLUOROSCOPY TIME, RELEASE X-RAY COMMAND	Fluoroscopy time has exceeded 5'.	Reset time with reset key on stand control panel.
10	The stand reads: X-RAY TUBE THERMAL SAFETY	Monoblock overheated.	Do not command X-rays (unless absolutely necessary) and wait for the monoblock to cool down.
11	The control panel reads: RX TUBE TOO HOT	Monoblock too hot for exposure in radiography mode using the current parameters.	Do not command X-rays (unless absolutely necessary) and wait for the monoblock to cool down.
12	The control panel reads: NO RX	Fuses on TB2 blown: F2, F3, F4 and F5 in entrance of X-ray generator.	Replace fuses on TB2: F2, F3, F4 and F5.
		X-ray generator faulty.	Replace the X-Ray generator.
		Reduce mains voltage.	Check the mains voltage. Check the apparent resistance of the mains circuit.
13	The control panel reads: MANUAL X-RAY STOP	The X-ray emission command button has been released too early during a radiography exposure.	Repeat radiography.
14	The control panel reads: MAX RADIOGRAPHY TIME	Radiography exposure has exceeded the limit of 1 s.	Check correct mA. Check exposure mA displayed on monitor.
15	The control panel reads: ANODE STARTER FAULTY	During preparation for radiography, the anode fails to start turning.	Check X-ray generator/monoblock connections. X-ray generator faulty.

Nr.	PROBLEM FOUND	PROBABLE CAUSE	RECOMMENDED ACTION
16	The control panel reads: mA TOO LOW	mA value has dropped below 10 mA during radiography.	Check the mains voltage. Check the filament SET values in the Set-Up menu.
		During fluoroscopy, mA value too low (1/3 the set value).	Check the mains voltage. Check the filament SET values in the Set-Up menu.
17	The control panel reads: mA TOO HIGH	mA value too high in fluoroscopy (1.5 times the set value).	Check the mains voltage. Check the filament SET values in the Set-Up menu.
18	The control panel reads: NO XRAY ENABLE FROM DETECTOR	The video processor is not ready to acquire images or the detector fails to provide the XRAY ENABLE signal (XREN).	Check that the working frame opens on the Monitor.
19	The control panel reads: X-RAY COLLIMATOR FAULT	X-ray collimator fails to reach the correct position or does not communicate with board CTBK (CAN messages).	Check collimator power supply and CAN connections with board B1 (CTBK).
20	The control panel reads: DAP FAULT	The DAP meter fails to send the correct number of calibration pulses immediately after being switched on.	Check the DAP output signal (pulses).
21	The control panel reads: FLUOROSCOPY PEDAL CLOSED	Low Dose Fluoroscopy footswitch found to be closed when equipment switched on.	Check efficiency of fluoroscopy footswitch and its connections.
22	The control panel reads: FLUOROSCOPY PEDAL HQ CLOSED	High Quality Fluoroscopy footswitch found to be closed when equipment switched on.	Check efficiency of fluoroscopy footswitch and its connections.
23	The control panel reads: RAD PREP BUTTON CLOSED	Radiography preparation button found to be closed when equipment switched on.	Check efficiency of the button and its connections.
24	The control panel reads: RAD BUTTON CLOSED	Radiography button found to be closed when equipment switched on.	Check efficiency of the button and its connections.
25	The control panel reads: LOW DOSE AT MAX KV	Insufficient dose level detected at max kV (120) (Vabc signal from detector).	
26	The control panel reads: NO X-RAY DOSE SIGNAL	Fault in the dose reading circuit: the DOSE CONTROL messages are not received from the VIDEO PROCESSOR.	Check the video processor SW LOG.
27	The control panel reads: POSSIBLE DETERMINISTIC EFFECTS	Attention: The accumulated Kerma Rate has exceeded the threshold during the study and so there is a risk of DETERMINISTIC EFFECTS.	

Note: The manufacturer undertakes to supply, upon request, full information (wiring diagrams, component lists, calibration instructions, etc.) to assist qualified technical personnel in repairing any equipment components that the manufacturer feels can be repaired.

2.2 REPLACING COMPONENTS

Every time a component is replaced, a series of checks and adjustments need to be performed. Consult the table below which covers the most common situations.

Nr	COMPONENT REPLACED	ADJUSTMENTS AND CHECKS REQUIRED	REFERENCE
1	ARCO FP-S video processor	Check and configure	Part 2, chapter 4
2	Flat panel detector	Detector calibration	Part 4, chapter 3
3	Monoblock / X-ray generator	X-ray generator adjustment	Part 4, para. 2.1
4	X-ray collimator	X-ray collimator adjustment	Part 4, para. 2.2
5	B1 board (CTBK-HW)	Check and configure	Part 5, para. 2.4.1
6	Laser localizer	Adjusting the localizer devices	Part 4, para. 2.3
7	B2 board (ASAC 01)	Check column up/down movement adjustments	Part 4, para. 2.4
8	DAP	Check and configure	Part 4, para. 2.1.4

2.3 RESTORING THE VIDEO PROCESSOR SYSTEM HARD DISK

If necessary, you can restore the system disk of the video processor using the backup USB PEN DRIVE (the "image file") supplied with the equipment.

The manufacturer made this backup on completion of factory testing.

The USB pen drive is found inside the stand, attached to the video processor group (see next photo).

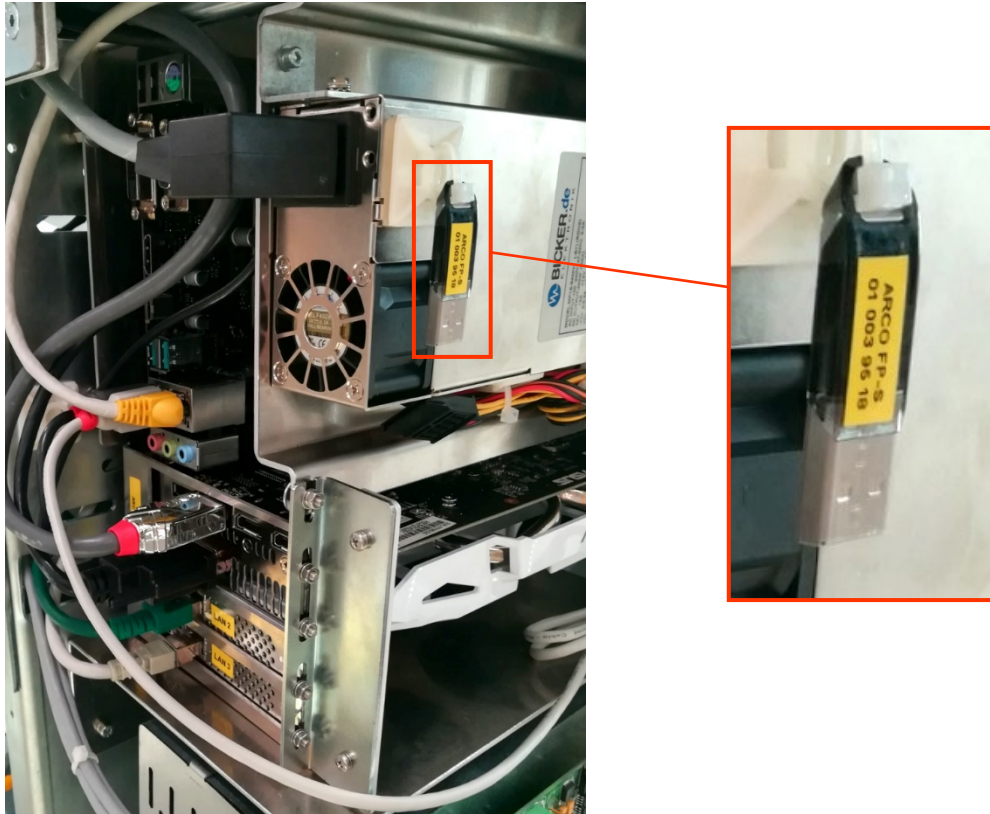

To restore the system disk, please follow this procedure:

- 1) Access the video processor group by removing the cover of the stand (see instructions in para. 5.1.3 of this section in the present manual).
- 2) Remove the USB pen drive shown in the photo above and connect it to one of the USB ports present on the motherboard of the video processor.
- 3) Connect a USB keyboard and mouse to the USB ports (CB5, CB6) on the stand.
- 4) Turn on the equipment and press the "DEL" key on the keyboard to enter the UEFI BIOS Utility:

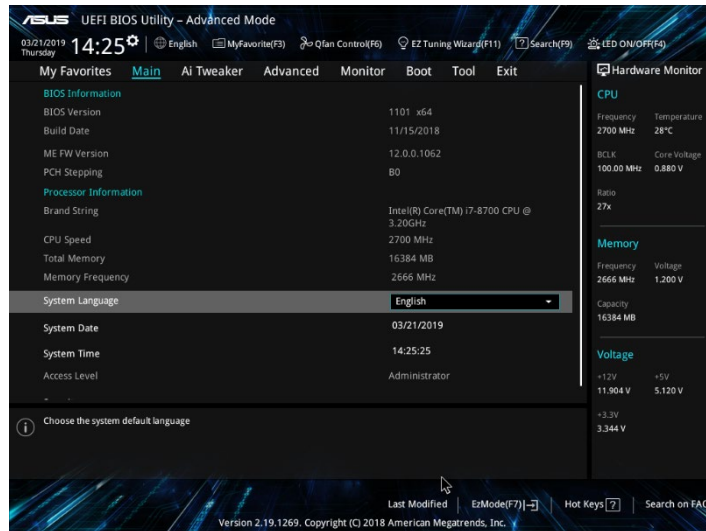

5) Enter into the **Boot** menu and select the USB pen drive (**UEFI: SanDisk**) as booting device:

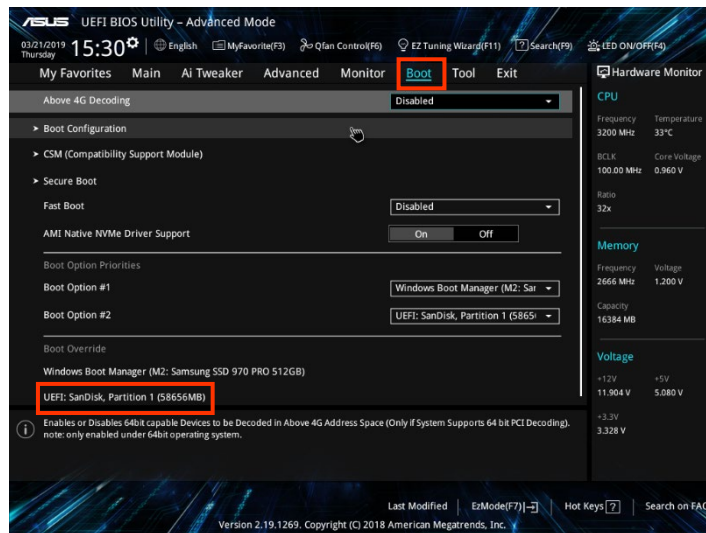

6) The processor will restart automatically and the equipment will display the start screen of the recovery application **Macrium Reflect**:

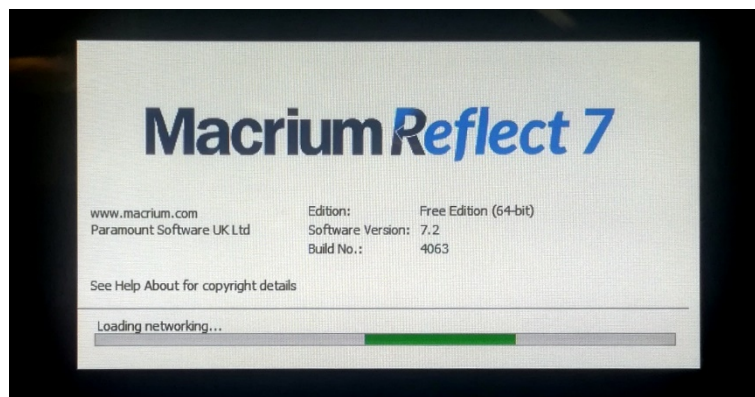

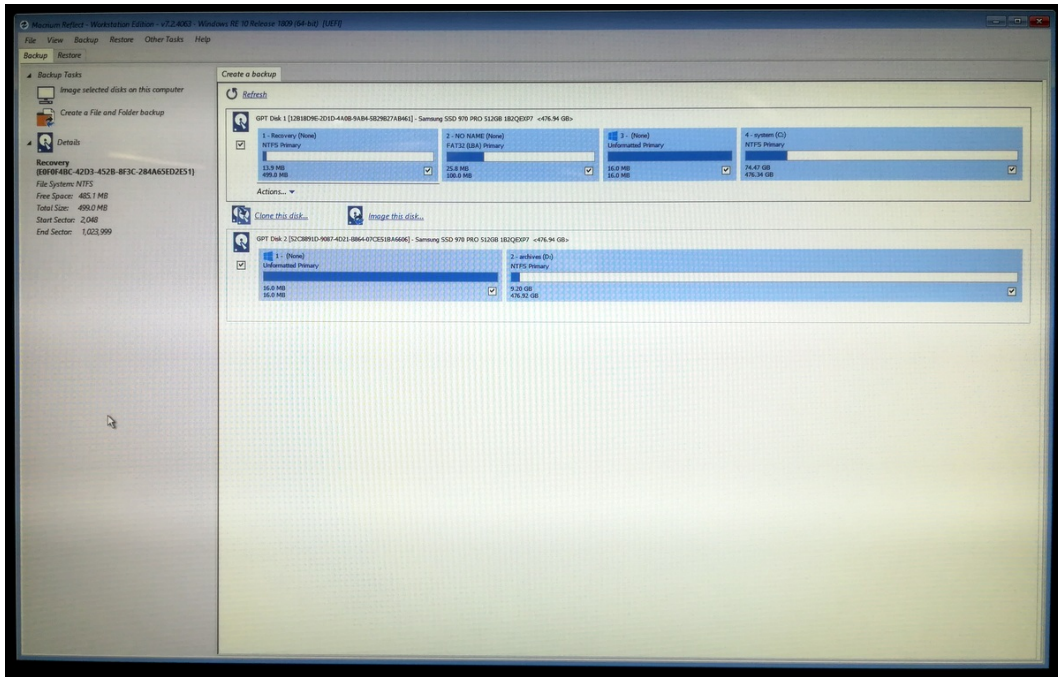

7) On the main screen, click on the **“Restore”** tab and then on **“Browse for an image file...”**

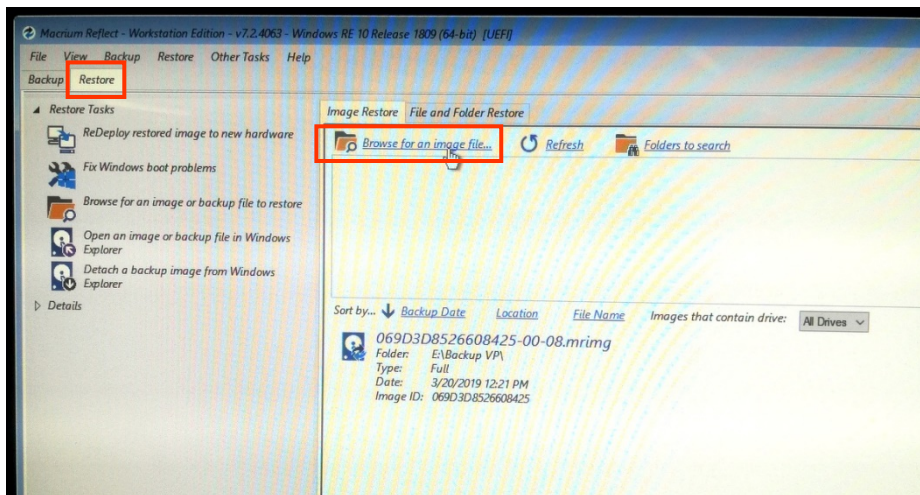

8) Select the USB pen drive (**Removable Storage**) and after that the folder **“Backup VP”**:

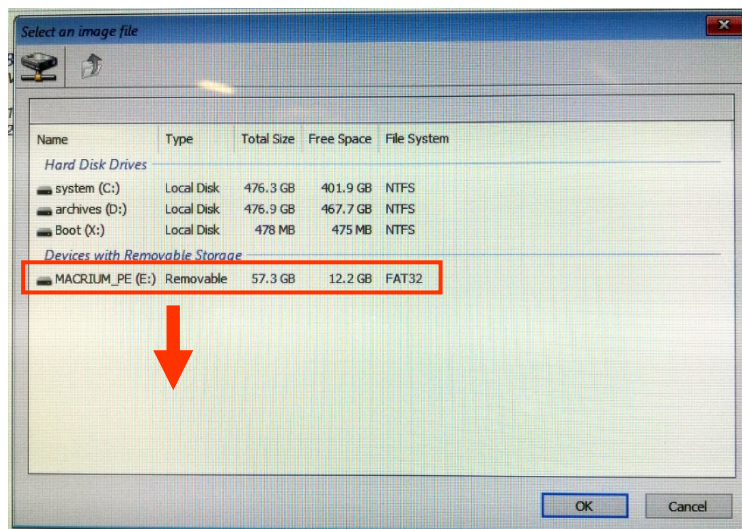

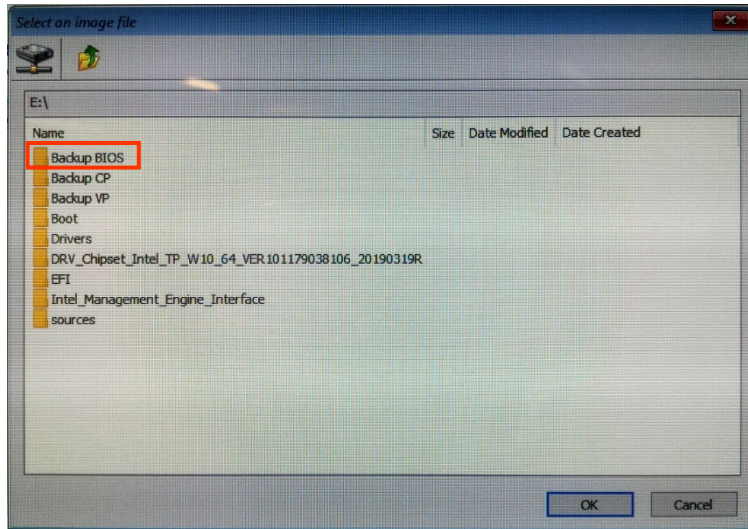

9) Then select the first file of the list which makes up the entire backup and press "OK":

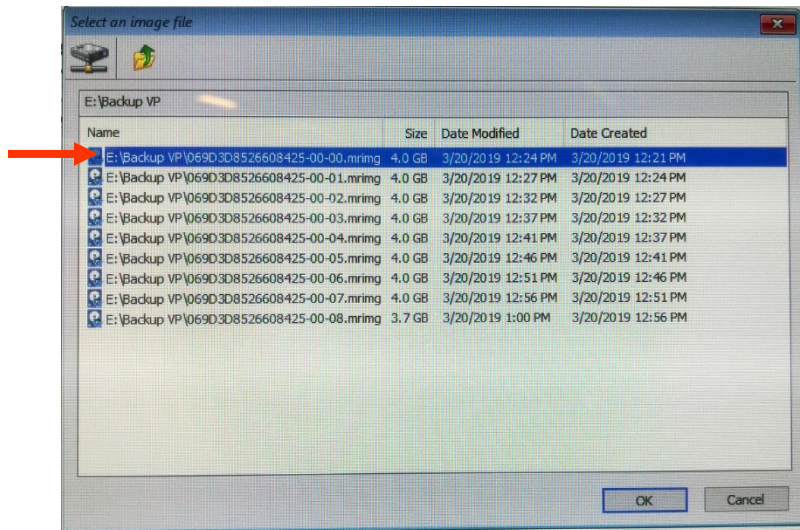

10) The selected backup will be shown on the main screen; now select the command "Restore Image".

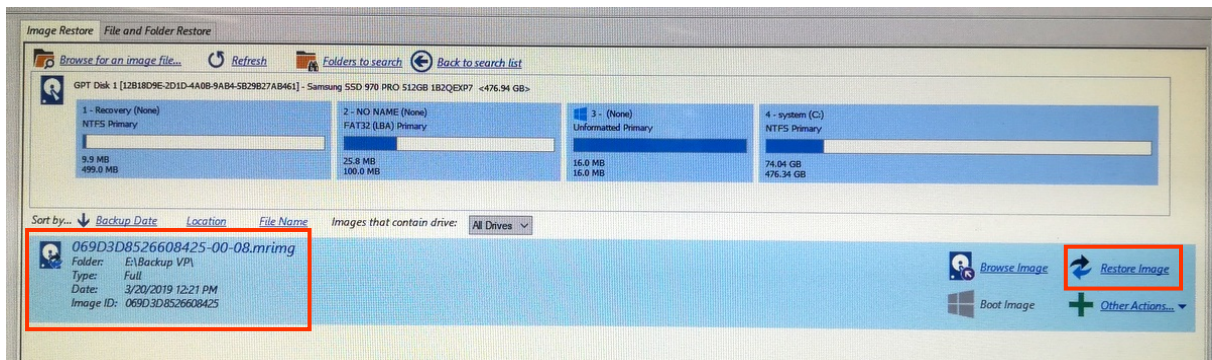

- 11) Check that:
 - in the frame "**Source**" all 4 partitions are selected which make up the system disk
 - in the frame "**Destination**" the same 4 partitions are present
 Then select the command "**Next**".

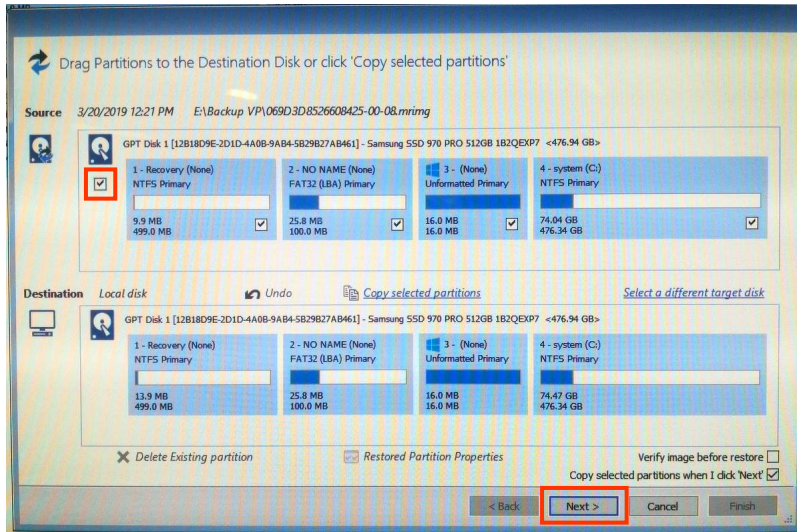

- 12) In the screen summarizing the selections, press the command "**Finish**":

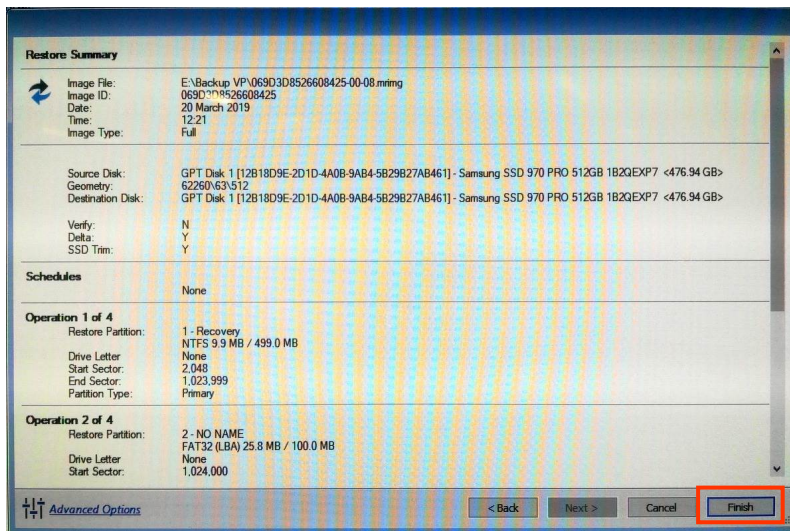

- 13) Confirm with the command "**Continue...**" to start the data recovery of on the system disk

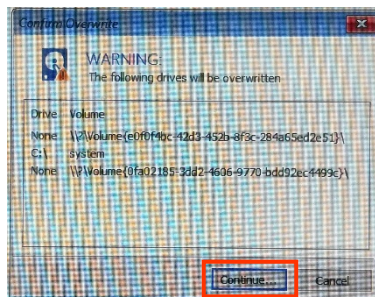

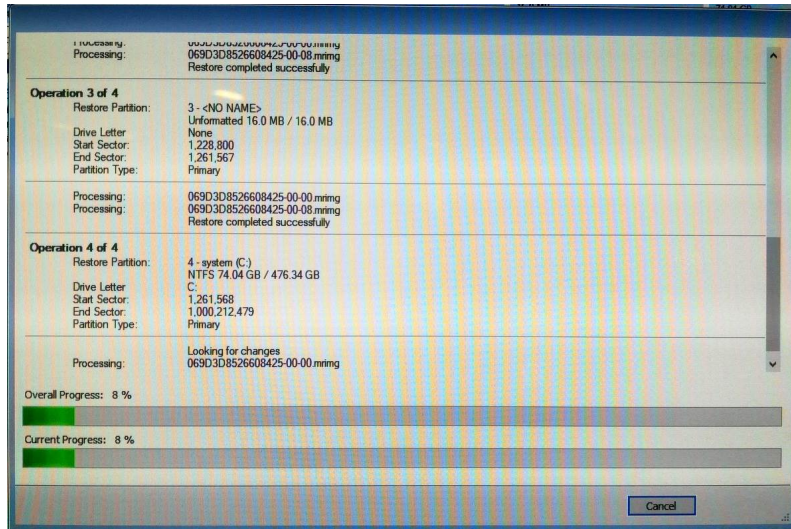

14) At the end of the recovery, select the command "OK" and close the application.

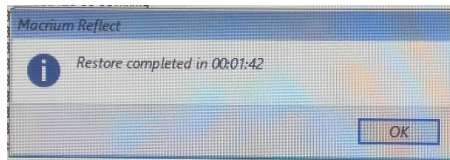

15) The video processor will then reboot automatically. Remove the pen drive, keyboard and mouse.

2.4 SOFTWARE UPDATES

This chapter describes the update procedure for the:

- the main controller software (board CTBK- HW)
- the software SystemA DRF-S (video processor and control panel)

2.4.1 UPDATING THE MAIN CONTROLLER SOFTWARE (CTBK-HW)

The Main Controller software is found on board B1 – CTBK-HW (stand).

The update procedure needs the following:

- Application **PIC32 Bootloader Application V1.4** (pre-installed on the PC of the monitor stand).
- Binary file **CTBK-FW_FP-S.X.production.hex** of the new firmware (CTBK-FW).

- 1) Connect to the USB sockets: CB5 and CB6 a USB keyboard and mouse.
- 2) Switch on the equipment.
- 3) Exit the SystemA DRF-S application and then access the video processor as “Administrator” (see paragraph 5.3 in Part 2 of this manual).
- 4) Run the **PIC32 Bootloader Application** by using the icon on the desktop:

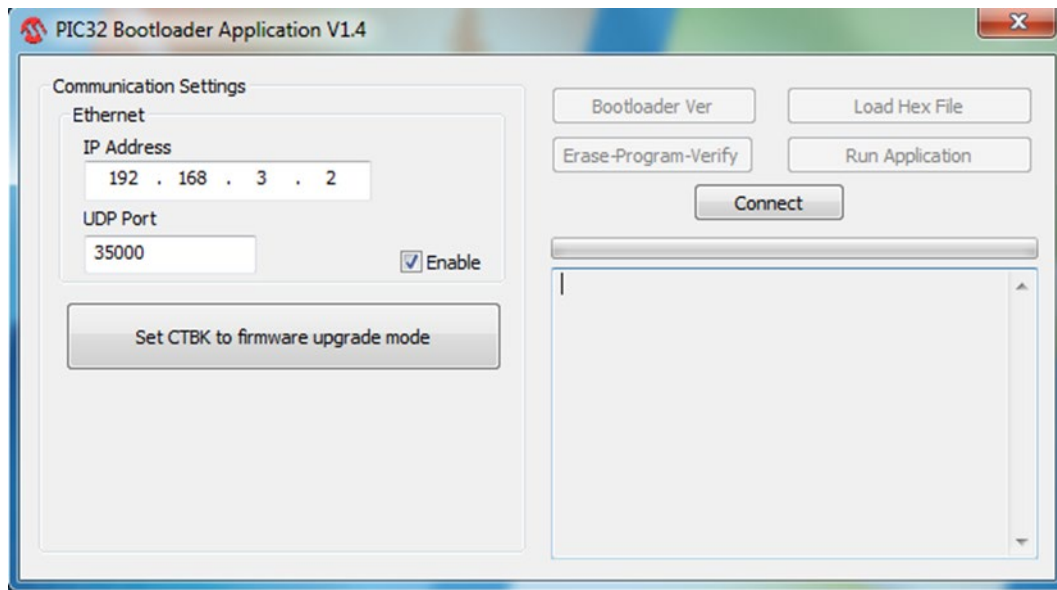

- Set the board CTBK connection as shown in the figure:

- o IP Address: **192.168.3.2**
- o UDP Port **35000**

- Make sure that **Enable** is checked.

- 5) Put board CTBK-HW in FIRMWARE UPGRADE mode by selecting the **Set CTBK to firmware upgrade mode** button.

- 6) The following window opens:

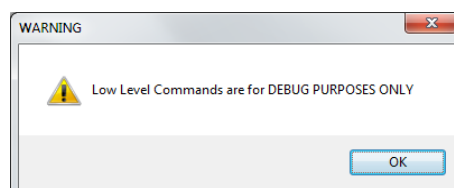

- 7) Confirm with OK.
- 8) If the equipment successfully enters the firmware upgrade mode, the following message appears:
“Device set to Upgrade Firmware Mode, ready for the second phase”

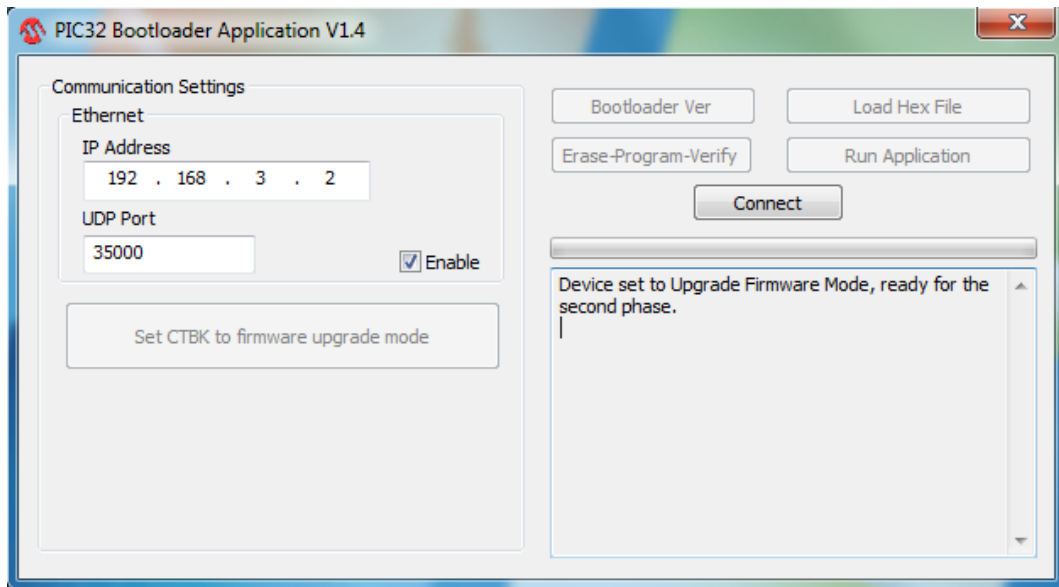

- 9) Wait about 20 seconds to allow the Bootloader to run and for propagation of the IP ADDRESS for board CTBK-HW.
- 10) Connect by selecting **Connect**.
- 11) If the bootloader version "Bootloader Firmware Version 1.0" appears in the following window: then the connection with board CTBK-HW has been successful.

*If connection is not established, try again to press **Connect** key after 30 seconds.*

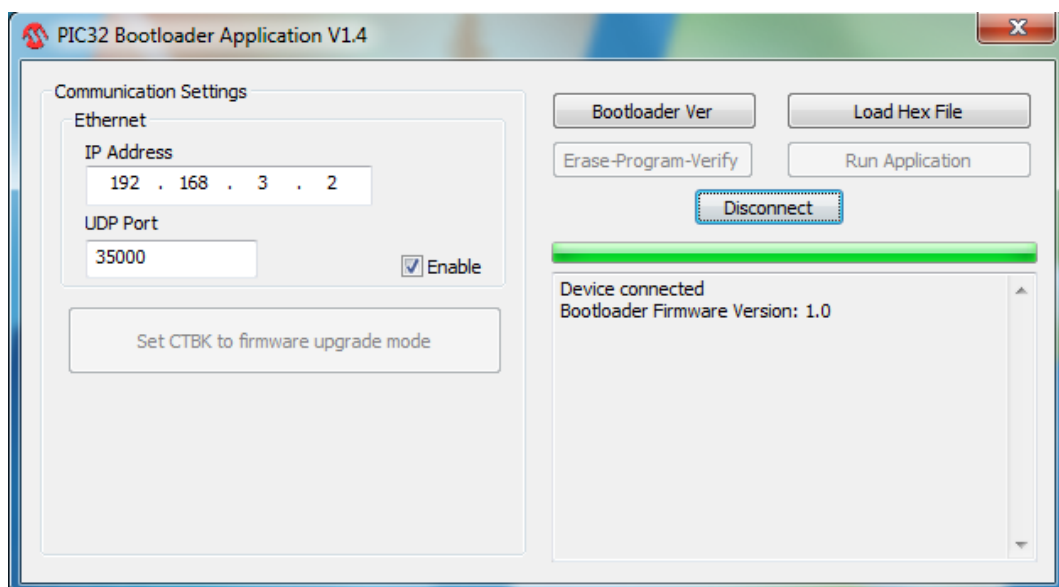

- 12) At this moment, touch the Load Hex File button and select the file containing the new firmware.
 This is normally named: **“CTBK-FW_FP-S.X.production.hex”**

13) The line “**Hex file loaded successfully**” should now appear.

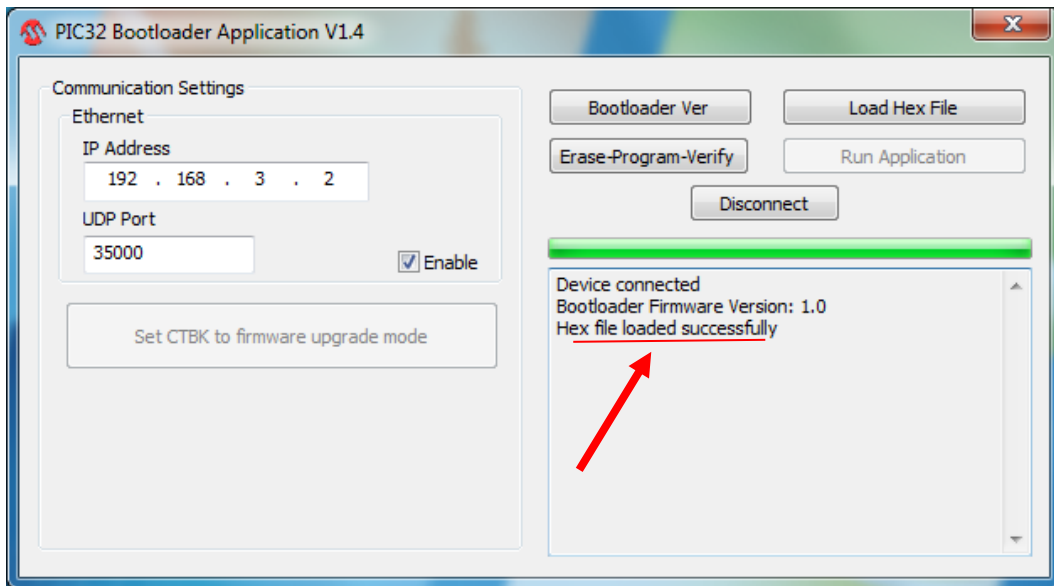

14) Select **Erase-Program-Verify** button

15) The following lines will appear in this order:

- **Flash Erased**
- **Programming completed**
- **Verification successful**

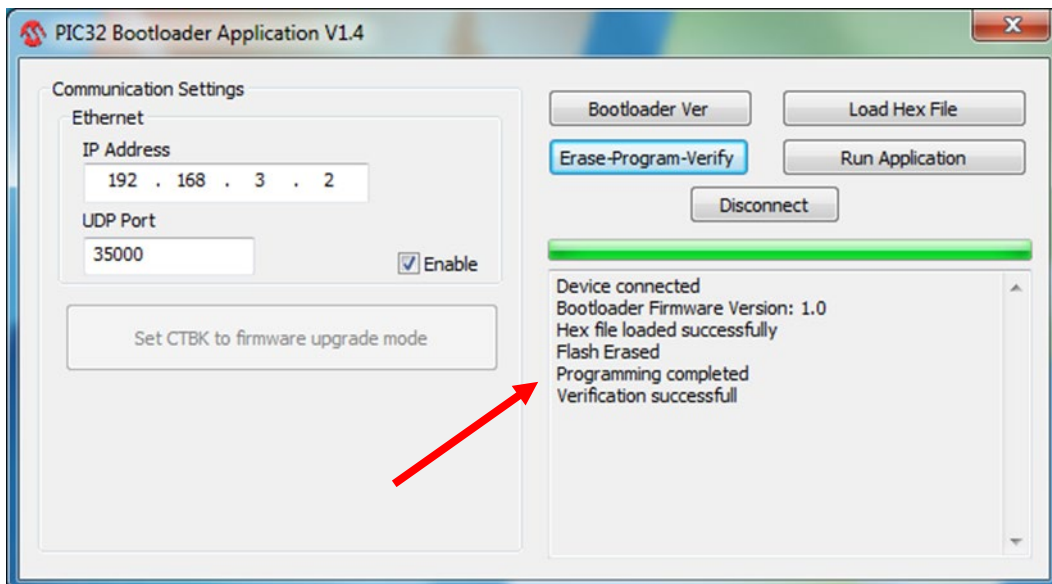

16) Select **Run Application**; you will hear a beep indicating that the new firmware is running.

17) Close the **PIC32 Bootloader Application** by selecting **Disconnect** and then the close window command “X”.

2.4.2 UPDATING THE SYSTEMA DRF-S SOFTWARE

The application **SYSTEMA DRF-S** is installed on the video processor as well as on the control panel. This means that, whenever a software upgrade is needed, you must change the software on both devices.

Updating procedure:

a) VIDEO PROCESSOR

- 1) The software you wish to install must be copied from on a USB pen drive:
 - **Setup_SystemADRFs_x.x.x.xxxxx_x64.exe**
- 2) Access the video processor group by removing the cover of the stand (see instructions in para. 5.1.3 of this section in the present manual).
- 3) Connect the USB pen drive to one of the USB ports present on the motherboard of the video processor.
- 4) Connect a USB keyboard and mouse to the USB ports (CB5, CB6) on the stand.
- 5) Access the operating system with user **Admin2** (password: 24060); the following page appears:

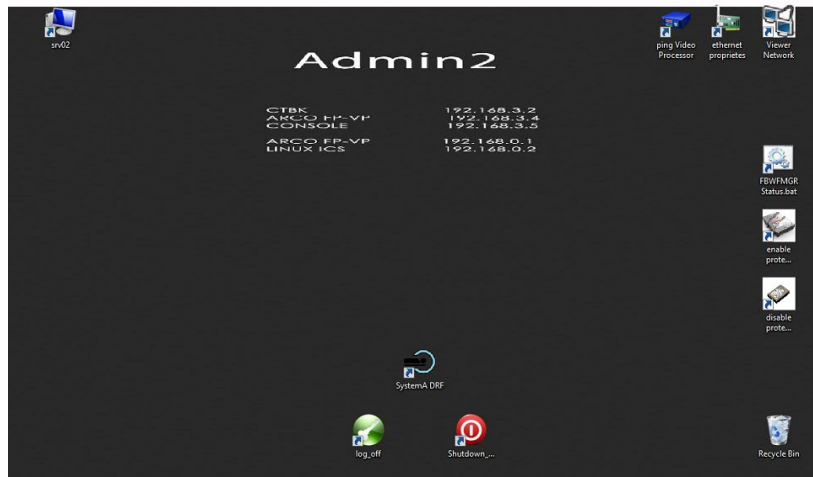

- 6) Check whether "**PROTECT HD**" is enabled. You need to open the "**FBWFMGR STATUS**" (File-Based Write Filter) program to do this. The following window appears:

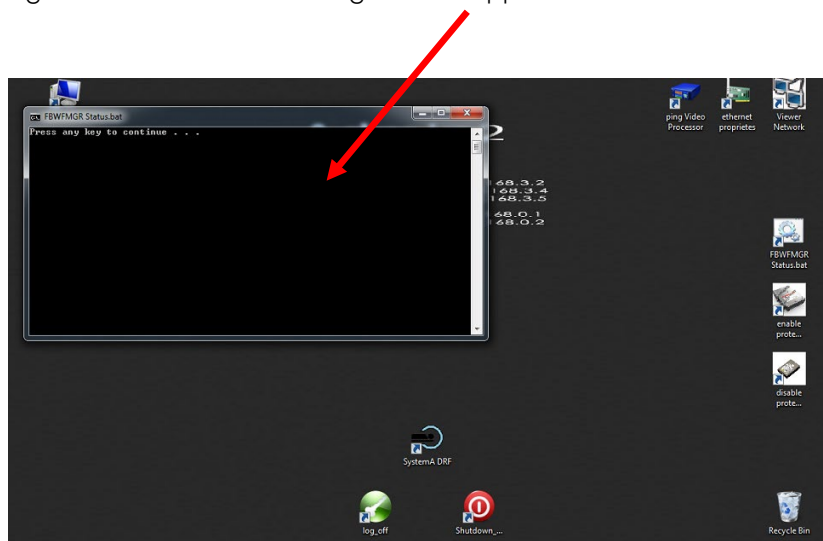

Press any key and the program will now run and produce a report on its current configuration. If operating, the writing "ENABLED" will appear on the third line; if turned off, "DISABLED" will appear. Close the window with the relevant key.

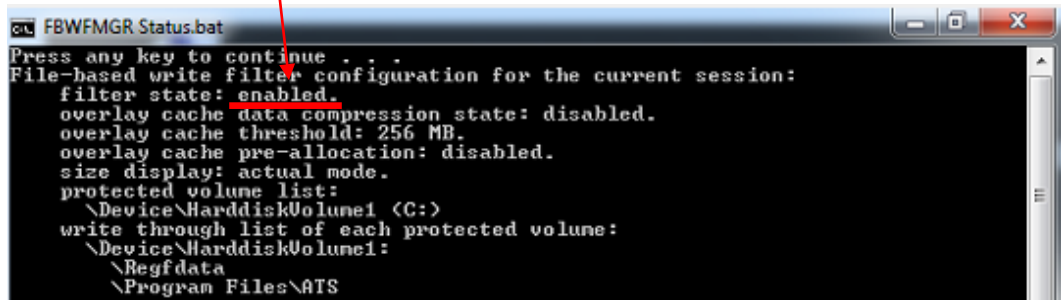

7) If the program is disabled, skip to point 8). If the program is active, open the "**DISABLE PROTECT HD**" software.

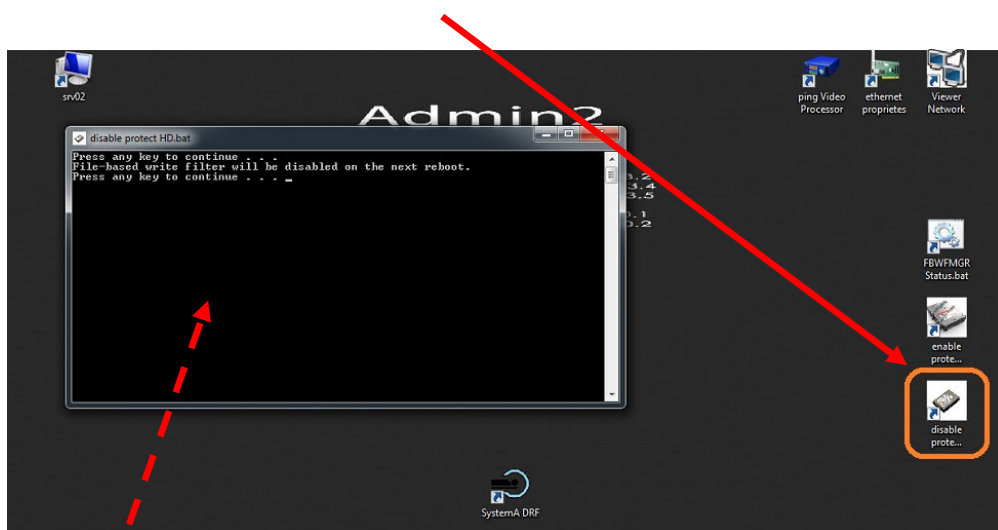

8) The window shown appears. Press any key to launch the program. The following sentence appears: The message "**PROTECT HD** will be disabled on the next reboot" appears.

9) Now close the window using the "X" key and reboot the computer.

10) Open the "**FBWF MGR STATUS**" program again to check that the deactivation procedure successfully accomplished. Press any key and the line "filter state: disabled" should now appear.

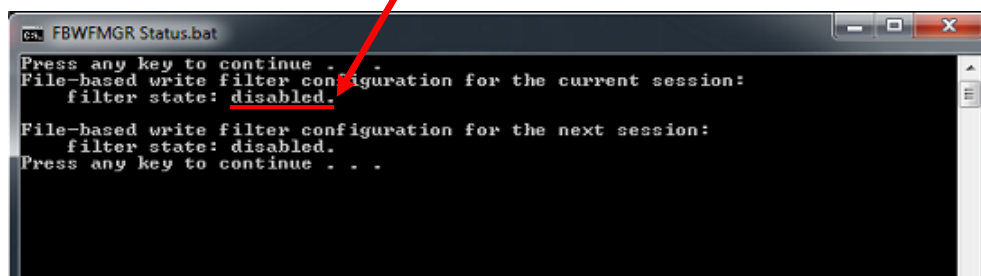

Close the window using the relevant key.

11) Open the Windows Control Panel and then open the "**Program and Features**" folder.

12) Remove the SystemA DRF-S application shown in the figure below:

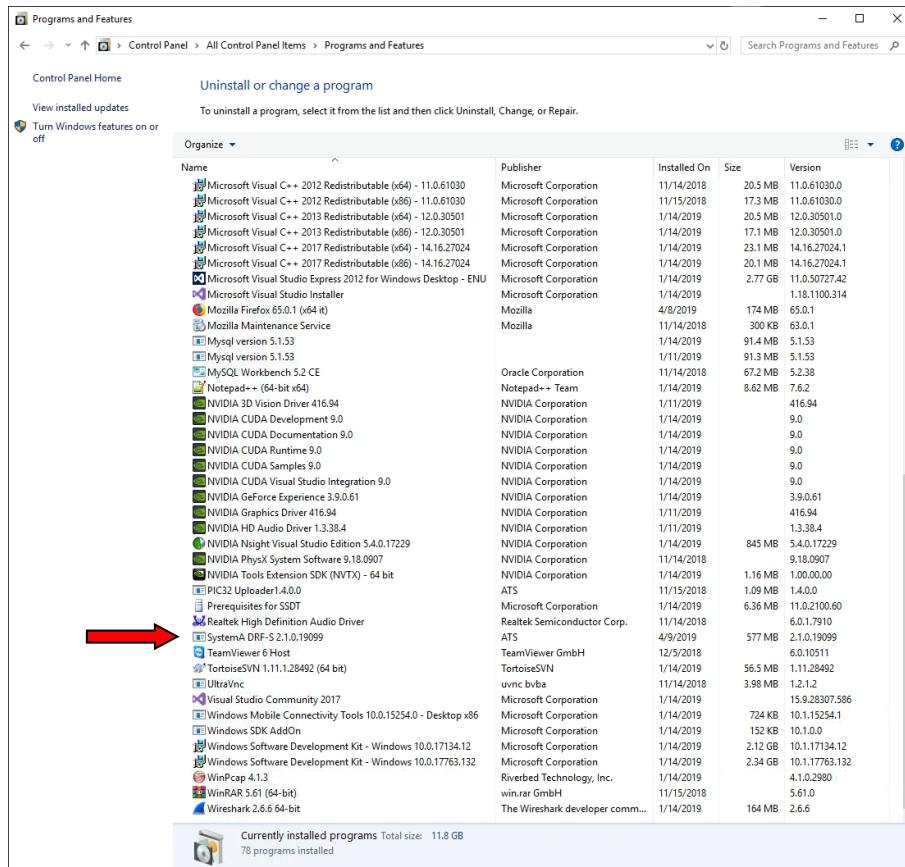

13) Open "Explore resources" and run the **Setup_SystemADRFs_x.x.x.xxxxx_x64.exe** program on the USB pen drive.
Complete the Install procedure by selecting the displayed option:

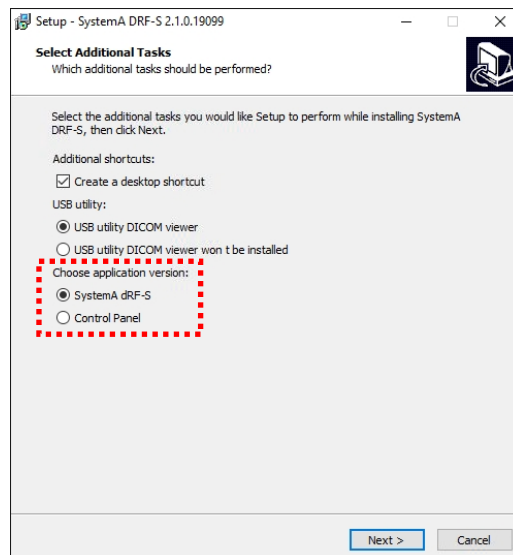

- 14) Enable again "**PROTECT HD**" by clicking on the program shown in the picture. Press any key: the program will run and the line "Protect HD will be enabled on the next reboot" appears.

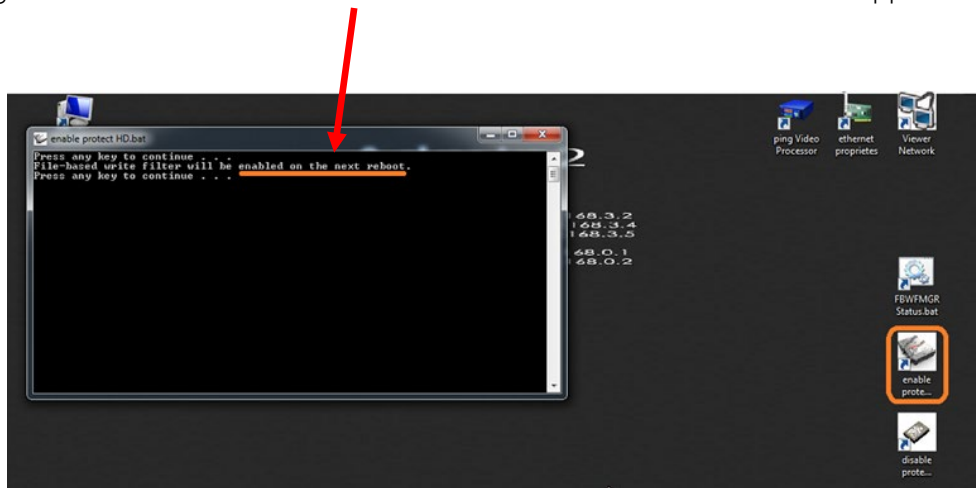

- 15) Finally, reboot the equipment to enable both the new Video Processor program manager **SYSTEMA DRF-S** and **PROTECT HD software**.

Now upgrade the software of the CONTROL PANEL (see point b, below).

b) CONTROL PANEL (PC panel)

Use the video processor to access the control panel (you cannot connect a keyboard or mouse directly to the control panel). To use this, open the "**Ultra VNC viewer**" remote support application.

- 1) Launch the "**Ultra VNC viewer**" application and enter the **IP Address: 192.168.3.5**, as shown in the following figure, then click on "**Connect**".

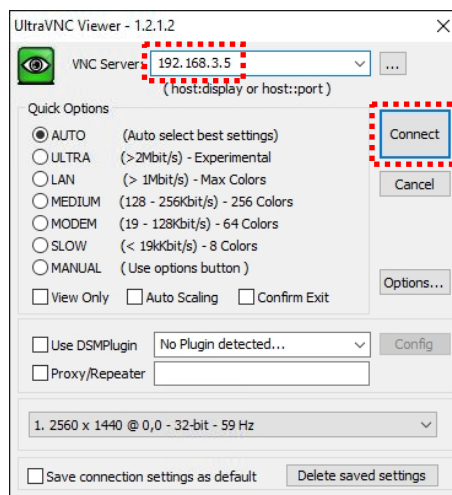

- 2) Log on to the operating system with user **Admin2** and follow the steps from the previous paragraph from **3)** to **8)**.
- 3) Close the window using the relevant key and go to the Windows **Control Panel**. Open the "**Program and Features**" folder. The window shown below now opens.

4) Remove the **SYSTEMA DRF-S** application shown in the figure below:

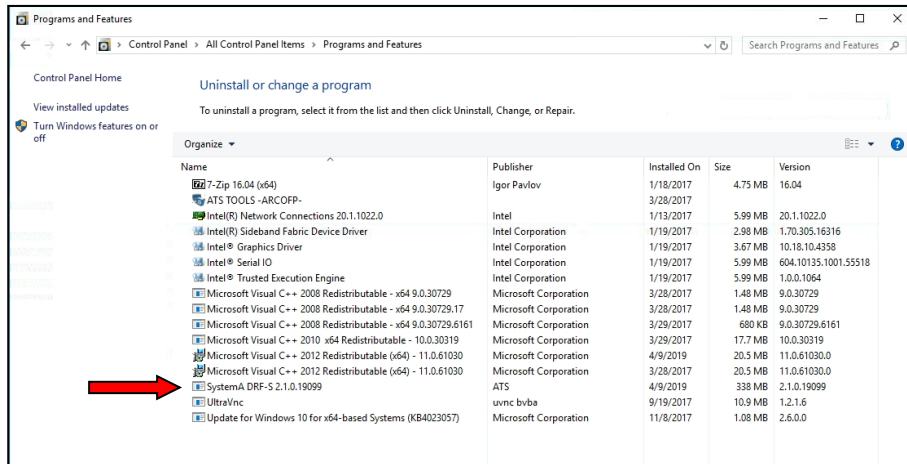

5) Transfer the installation file **Setup_SystemADRFs_x.x.x.xxxxx_x64.exe** from the pen drive to the control panel using the application **UltraVNC** and by pressing the key shown in the following figure:

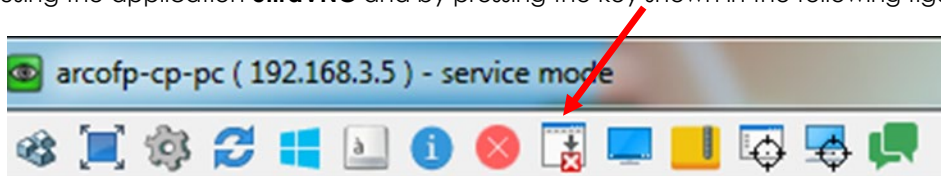

6) After pressing the key, the following page appears. Select the file which shall be sent to the left screen (video processor) and transfer it to the right screen (control panel) with the key **SEND**:

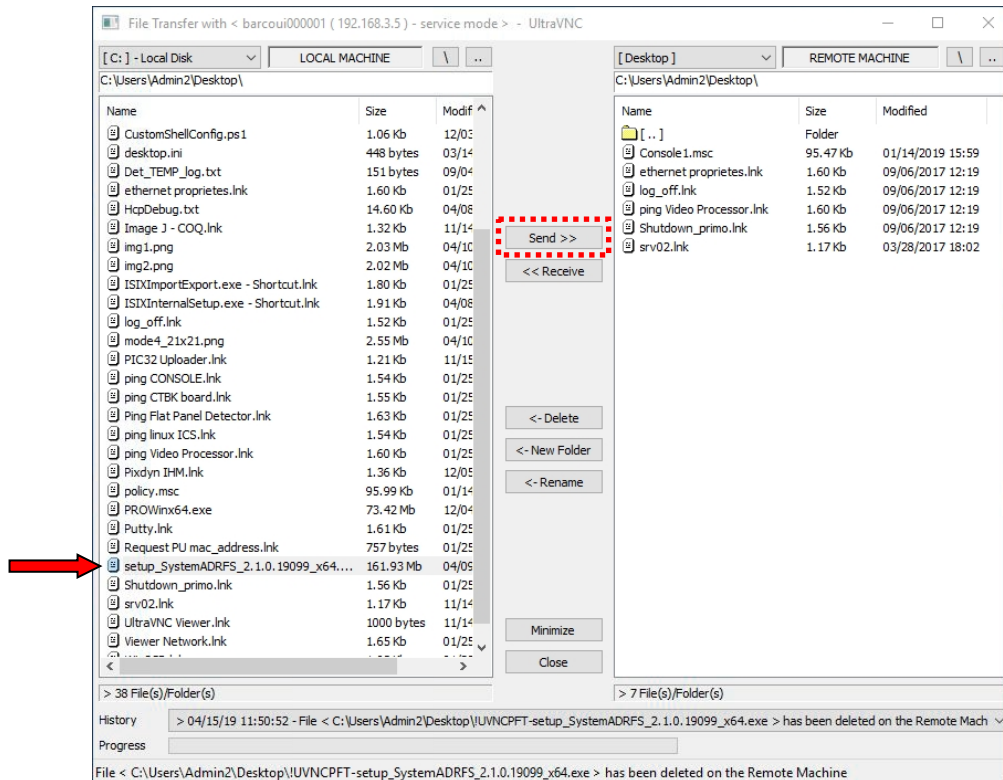

- 7) Launch the application **Setup_SystemADRF5_x.x.x.xxxx_x64.exe**
 Complete the Install procedure by selecting the displayed option:

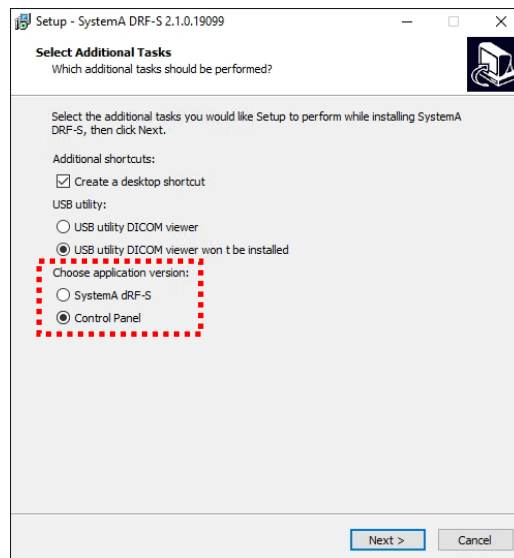

- 8) Enable again "**PROTECT HD**" by clicking on the program shown in the picture. Press any key: the program will run and the line "Protect HD will be enabled on the next reboot" appears.

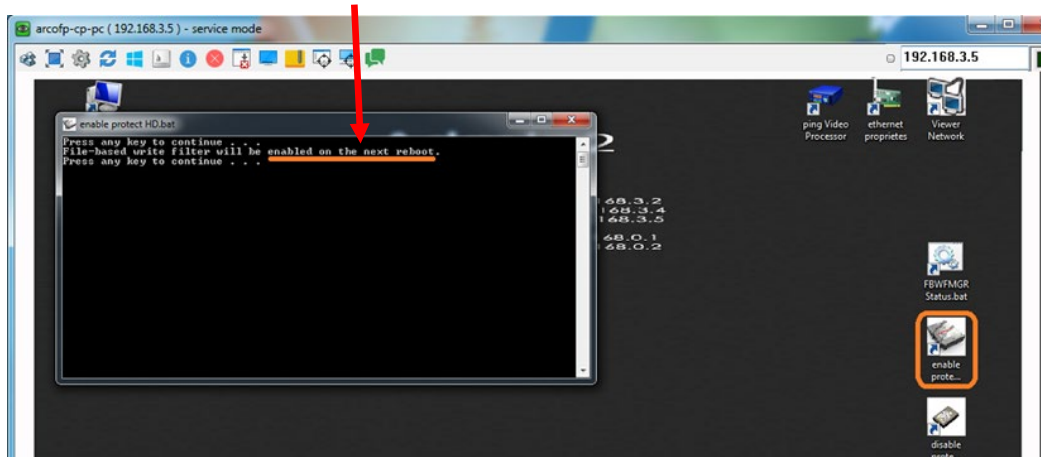

- 9) Finally, reboot the Control Panel computer to enable both the new Control Panel program manager **SYSTEMA DRF-S** and **PROTECT HD software**.

2.5 ADJUSTING THE MONITOR

Status indicator LEDs:

- OFF** = Monitor OFF
- RED** = Monitor in standby
- BLUE** = Monitor ON

Control KNOB

Status indicator LEDs

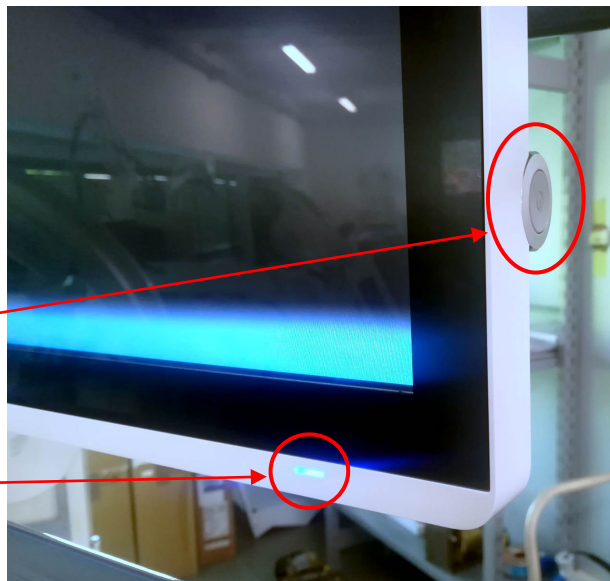

The manufacturer supplies the monitor with the settings in conformity with the DICOM standard.

➤ **Warning:** Never change these settings.

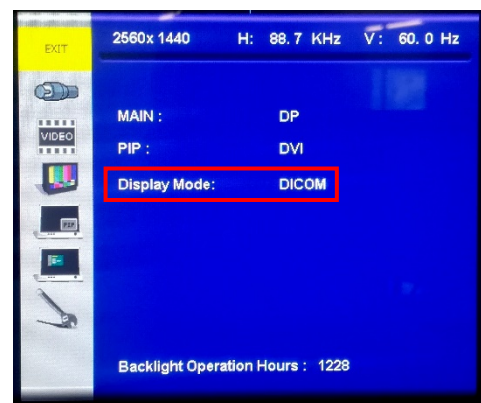

If the monitor ever loses these settings, you will need to access the menu for settings and adjustments (OSD menu) using the control knob on the right side of the monitor.

Note: as to avoid accidental activation of the monitor setup, normally this menu is locked and when pressing on the knobs, the message "OSD Locked" is displayed on the screen (see image next to it). In order to unlock it, press repeatedly on the knob until the initial screen of the OSD menu appears.

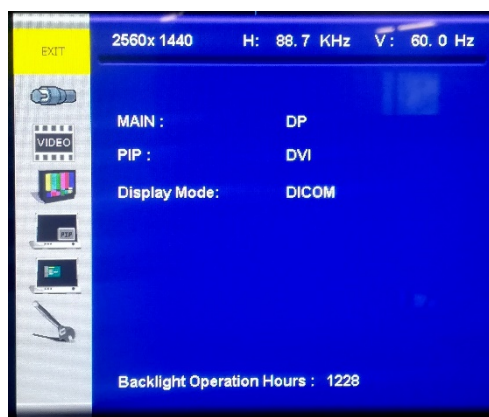
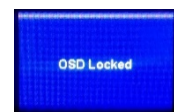

- Access the menu **Input Source Settings** and select the option **DP** (DISPLAY PORT).

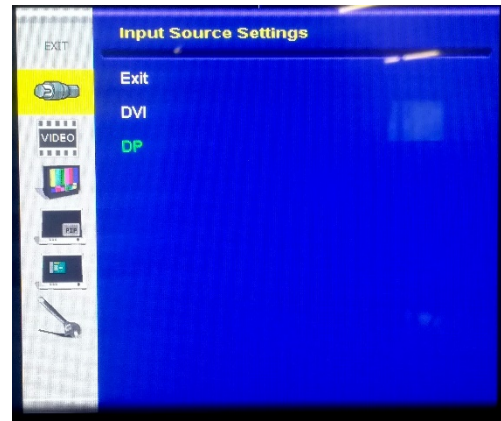

- Access the menu **Display Mode Settings** and set the following parameters:

- **Color Temp. = 9300K**
- **Gamma = DICOM**

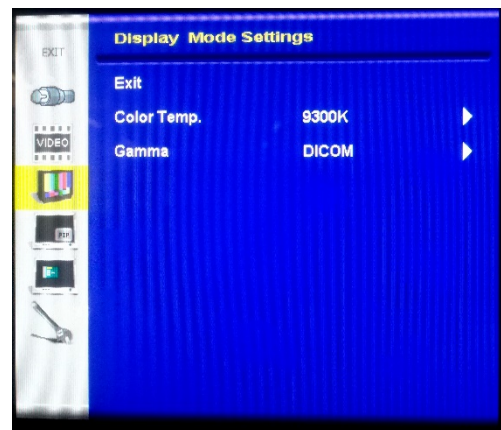

- Access the menu **Management Settings** and set the following parameters:

- **Scaling = Full**
- **Sleep Mode = Off**
- **OSD Lock = On** (for locking the OSD menu)

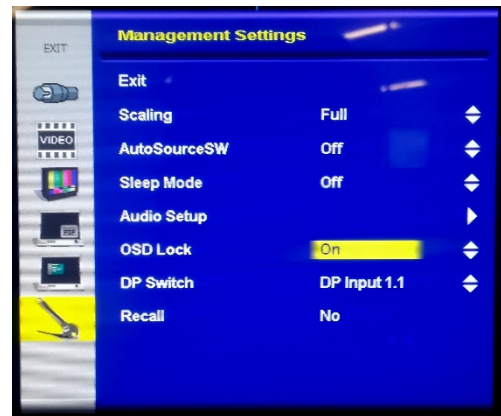

3 SPARE-PARTS

3.1 LIST OF SPARE-PARTS

- Note:** - When ordering spare parts, please quote the item code.
 - The numbering system used in the list refers to the figures below.
 - Please contact the authorized dealer for parts that are not included in the list below, or that are not numbered in the figures.

Nr.	Description	Code	Note / Model
1	Main power cable	550 95 005	
2	Stand/C-arm cable	550 95 003	
3	Kit of Control Panel and monitor cables	550 95 004	
4	2-command footswitch	74 07 400	Optional
	2-command footswitch Wireless	74 07 910	Optional
5	Remote control receiver	74 05 910	Optional
6 Stand rack unit			
6a	X-ray generator	IN 95 001	IMD mod.HF1 3,5Kw R
6b	Stand power supply group: - 3KVA insulating transformer (TR1) - CTBK-HW Board transformer (TR2) - 132VA actuator transformer (TR3) - Board B1 (CTBK-HW) - Board B2 (ASAC 01) - 24V feeder TDK-Lambda HWS150A/24MEA (PS2) - 12V feeder TDK-Lambda HWS100A/12MEA (PS3) - 24V feeder TDK-Lambda HWS30A/24ME (PS4)	95 01 720 TRASFP2 TSFRKD100 19 02 110A 74 01 100A 19 10 010A HW 86 401 HW 74 001 HW 95 001	
6c	ARCO FP-S/VP video processor	95 01 710	
6d	Board B5 (RKUD 00) UP/DOWN movement group	59 01 400	
6e	Board B4 (CTLD-HW)	74 01 300	
7 Display group			
7a	27" LCD color monitor	MO 27 002	Mod. GUP2762AMII-P
7b	Control Panel 12"	MO 12 002	Mod. Muip-2112.
8 Monoblock unit			
8a	Monoblock with rotating anode	MR 66 001	IMD mod. I-40R 15 RF
8b	Collimator protection cover	74 05 904A	
8c	Collimator Secondary collimator	CO 95 001 CO 74 101	Mod. R 650 QDASM / 010D Only with FPD 2121
8d	Dose Area Product	DS 74 001	Optional
9 Detector unit			
9a	Flat panel detector PaxScan 2121 DXV Flat panel detector PaxScan 3030 DXV	DT 74 003 DT 74 004	The image shows the version with FPD 2121
9b	Detector 21x21 cover Detector 30x30 cover	74 05 824A 74 05 834A	
9c	Anti-scatter grid ACS AL 215x215mm Anti-scatter grid ACS AL 315x315mm	GRDF215X21580CM GRDF315X31580CM	
9d	Single laser diode	44 10 012A	Optional

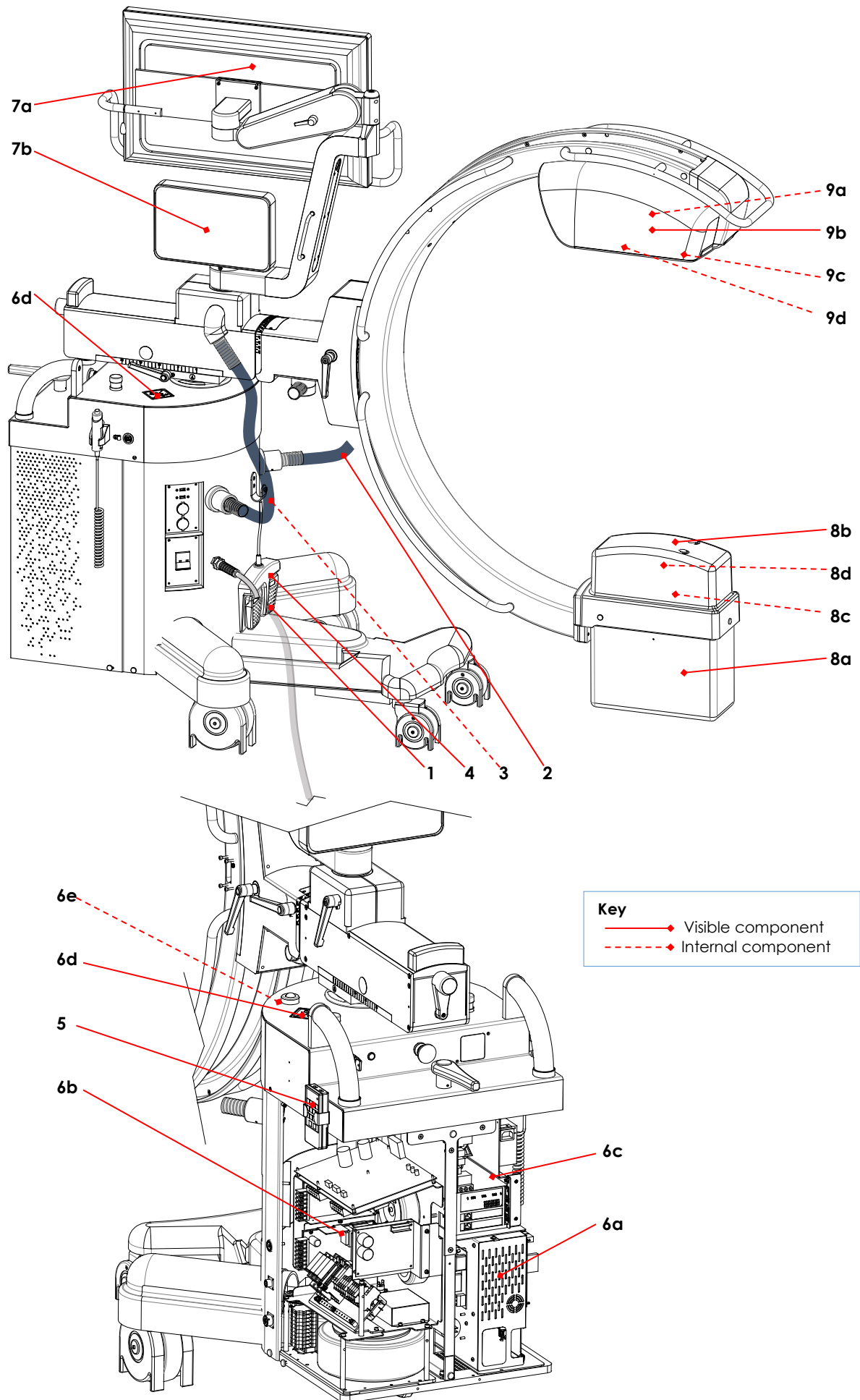

4 SCRAPPING

4.1 PROCEDURES AND PRECAUTIONS

When scrapping the device, special care must be taken when handling the following components as these can be hazardous when scrapped:



- The flat panel detector contains **cesium iodide doped with thallium** and **lead** that must be considered toxic materials.
- The LCD monitor has a **screen** which, should it break, can send shards of glass flying and disperse substances that may be toxic.
- The monoblock contains a **vacuum tube** which, should it break, can send shards of glass flying; it also contains **lead** that must be considered a toxic material; it also contains exhaust **oil** which must be disposed of in accordance with the current local regulations.
- The X-ray collimator contains **lead**: this is a toxic material and must be treated as such.
- All flat batteries must be disposed of in accordance with European Directive 2006/66/EC and subsequent amendments (concerning batteries and accumulators and battery/accumulator waste).

Other parts of the equipment are made from:

- ferrous material (frames, etc.),
- plastic (covers and guards, etc.),
- wiring,

These parts are not considered to be a potential source of hazards when scrapping the device.



*All parts should be disposed of in accordance with the prevailing regulations in each country **at the moment of scrapping.***



The symbol on the right appears on the equipment to remind you that the equipment meets European Environmental Directive 2012/19/EU (handling of Waste Electrical and Electronic Equipment - WEEE) and so must be scrapped in accordance with the relevant laws for separated waste disposal.



This equipment must not be disposed of as normal municipal solid waste: it must be taken to an expert waste disposal center or returned to the dealer, should you wish to replace it with a new model.

5 FITTING/REMOVING COMPONENTS



Before attempting to fit or remove any components, you must switch the EM equipment off and unplug it from the mains power supply.
Respect all the safety procedures reported in Paragraphs and Sub-Paragraphs 1.3.1, 1.3.2, 1.3.3, in Part 1 of this Manual.

5.1 FITTING / REMOVING THE COVERS

5.1.1 X-RAY MONOBLOCK COVER

To remove the X-ray monoblock cover:

- Unscrew the 3 screws (V) and remove the plastic washer (R).
(Attention: you can access a screw only after you remove its protective cap (T).)
- Extract the cover (C)

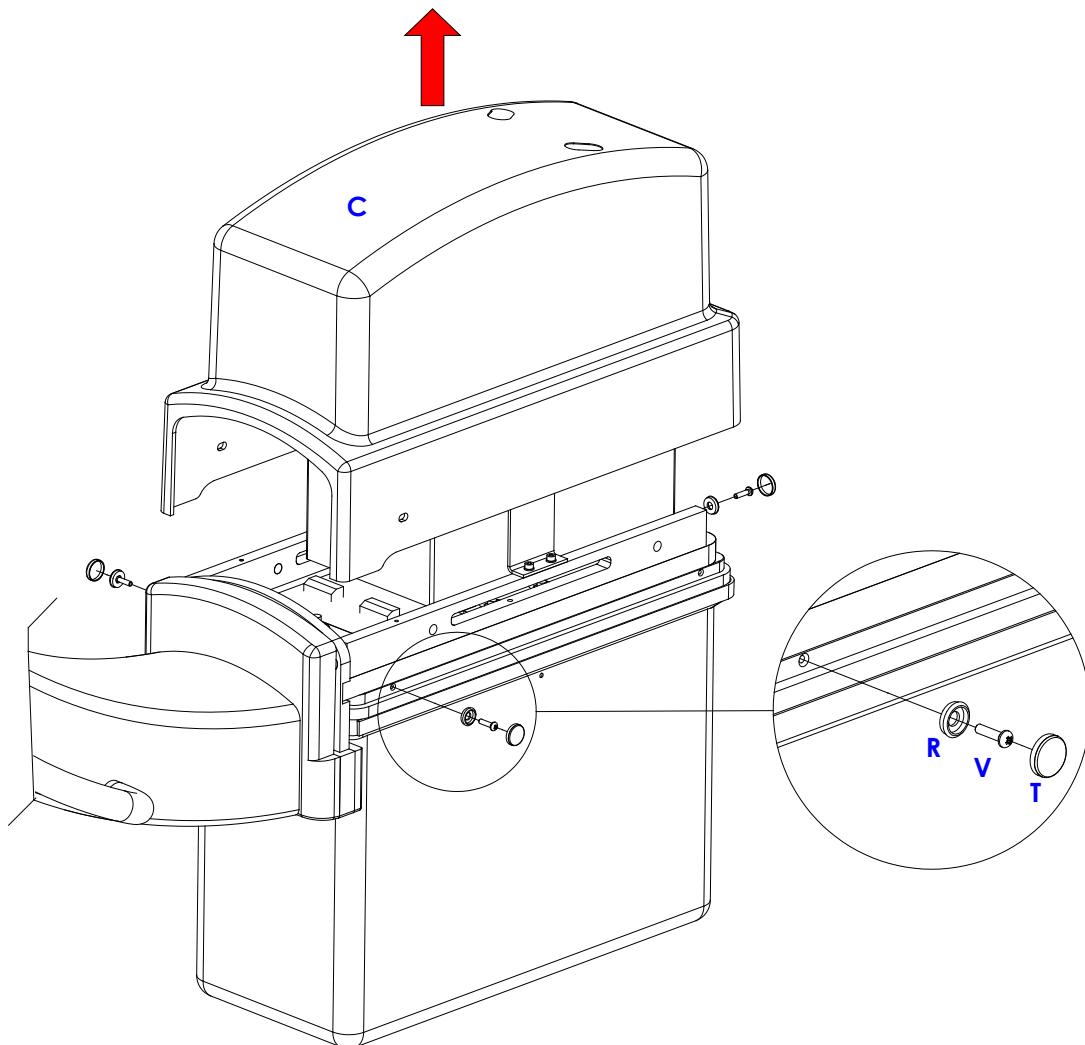

Fig. 1



Repeat the above steps in reverse order to remount the cover.

5.1.2 FLAT PANEL DETECTOR (FPD) COVER

To remove the FPD cover (C):

- Unscrew the 4 screws (Va). (In Fig.2a is shown the 21x21 FPD version).
- Remove the handle (M).
- Remove the laser unit (see paragraph 5.3.2).
- Remove the FPD (see paragraph 5.3.1).
- Unscrew the 6 screws (V). (In Fig.2b is shown the 21x21 FPD version).
- Extract the cover (C)

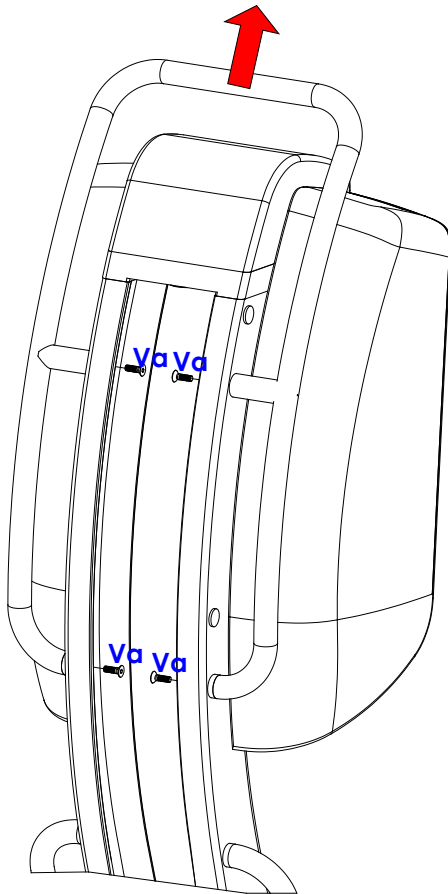

Fig. 2a

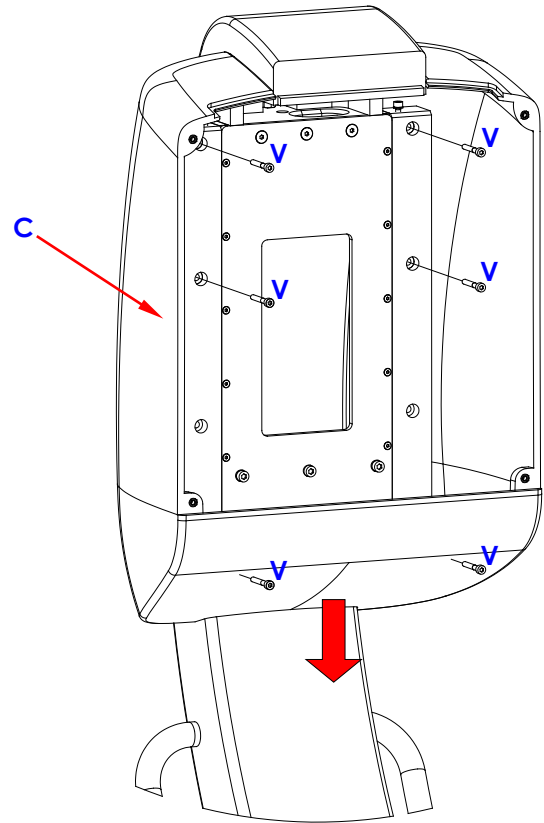

Fig. 2b



Repeat the above steps in reverse order to remount the cover.

5.1.3 STAND COVER

To remove the stand cover:

- Unscrew the 4 screws (V) and remove the plastic washer (R).
(Attention: you can access a screw only after you remove its protective cap (T).)
- Extract the cover (C)

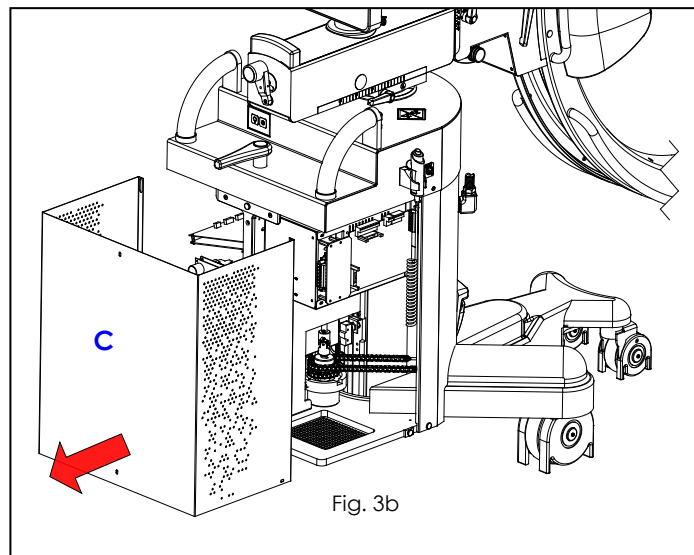
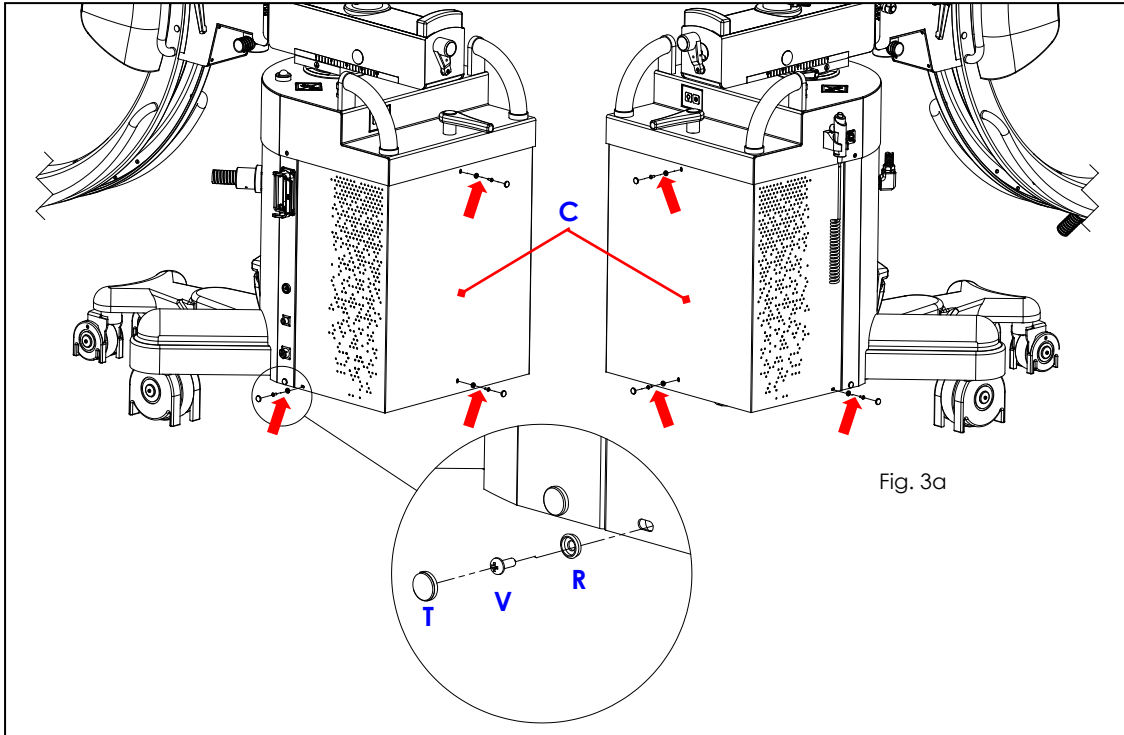

Repeat the steps above in reverse order to remount the cover of the stand.

5.2 FITTING / REMOVING THE X-RAY MONOBLOCK UNIT COMPONENTS

5.2.1 X-RAY MONOBLOCK



Warning: Before dismantling the X-ray monoblock, you must rotate the C-arm as shown in Fig.4a (with the FPD fully extended) and engage the brake (F) on the C-arm support, making sure that this stops the C-arm correctly.
You also need to place a wooden block under the stand (see Fig.4a) to prevent the equipment from toppling over when the X-ray monoblock is removed.

To remove the X-ray monoblock:

- Remove the X-ray monoblock cover (see paragraph 5.1.1 above).
- Disconnect the X-ray collimator connector.
- Remove the X-ray collimator (see paragraph 5.2.2 below).
- Remove the plate holding the collimator cone (see paragraph 5.2.2.1 - Fig.5b below).
- Unscrew the 2 screws (V) and remove the plate (P).
- Disconnect the X-ray monoblock connectors.
- Remove the 7 nuts (D) and their spring washers (R) (see Fig.4b).
- Remove the X-ray monoblock.

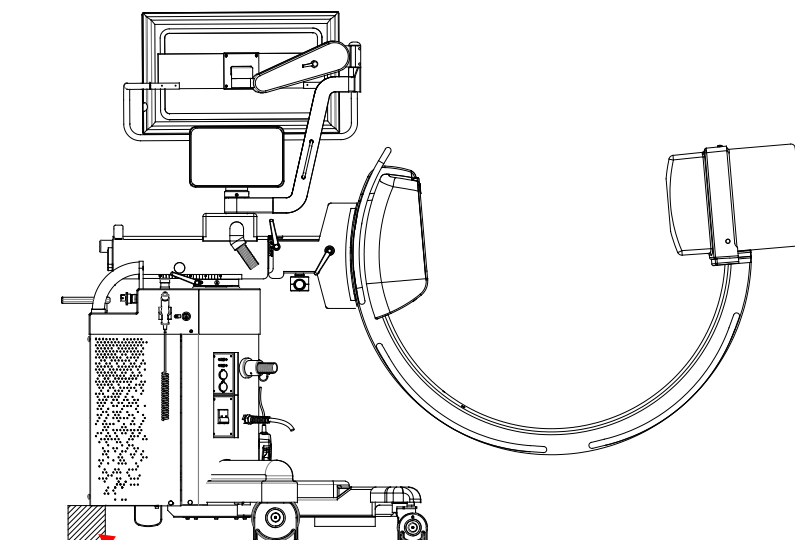

Fig. 4a

Wooden

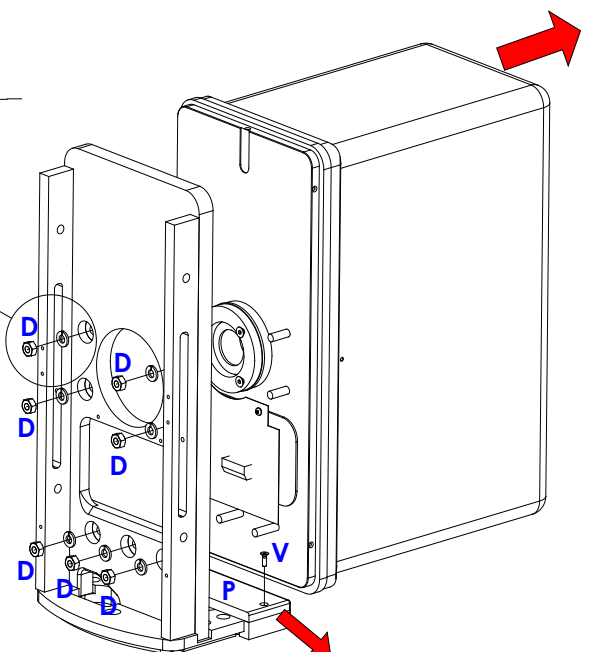
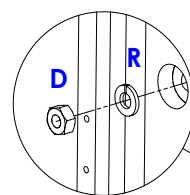

Fig. 4b



Repeat the above steps in reverse order to remount the X-ray monoblock.
After replacing the monoblock, you must re-calibrate the X-ray generator (see Chapter 2.1 in Part 4).

5.2.2 X-RAY COLLIMATOR UNIT

5.2.2.1 X-RAY COLLIMATOR

To remove the X-ray collimator:

- Remove the X-ray monoblock cover (see paragraph 5.1.1 above).
- Remove the Dose Area Product meter if present (optional) (see paragraph 5.2.2.2 below).
- Disconnect the X-ray collimator cable.
- Unscrew the 3 screws (V1) and then remove the cover (C1) on the X-ray collimator (see Fig.5a).
- Loosen the 3 grub screws (G) (see Fig.5b) and extract the X-ray collimator (C2).

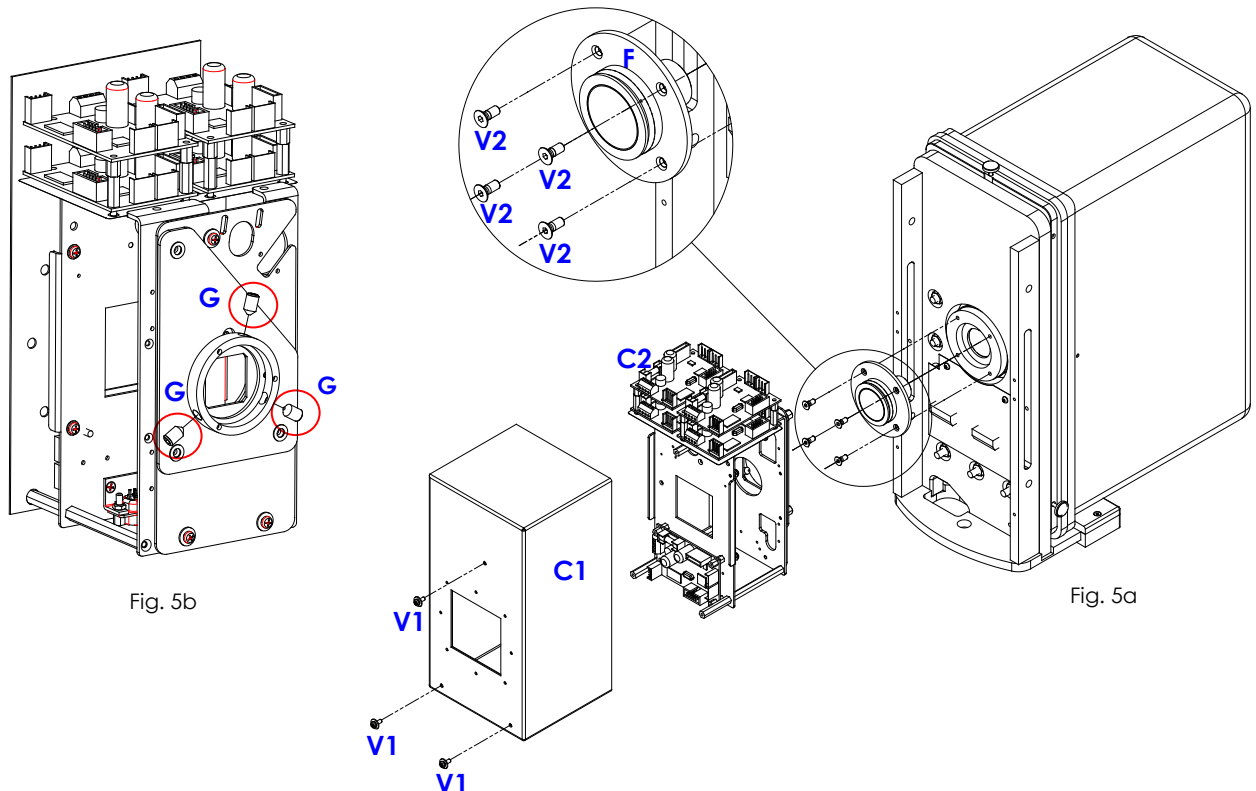

To remove the X-ray collimator cone (see Fig. 5a):

- Unscrew the 4 screws (V2).
- Remove the flange (F) holding the cone.
- Extract the cone from the flange.



Repeat the above steps in reverse order to remount the X-ray collimator.

Note: Check the centering of the X-ray collimator after re-mounting it (see Paragraph 3.3 in Part 4). You also need to check its calibration (see Chapter 2.2 in Part 4).

5.2.2.2 DOSE AREA PRODUCT METER (DAP)

To remove the DAP meter (optional):

- Remove the front cover on the X-ray monoblock (see paragraph 5.1.1 above).
- Disconnect the cable.
- Unscrew the 4 screws (V).
- Remove the support (S).
- Loosen the two grub screws (G).
- Extract the DAP (D).

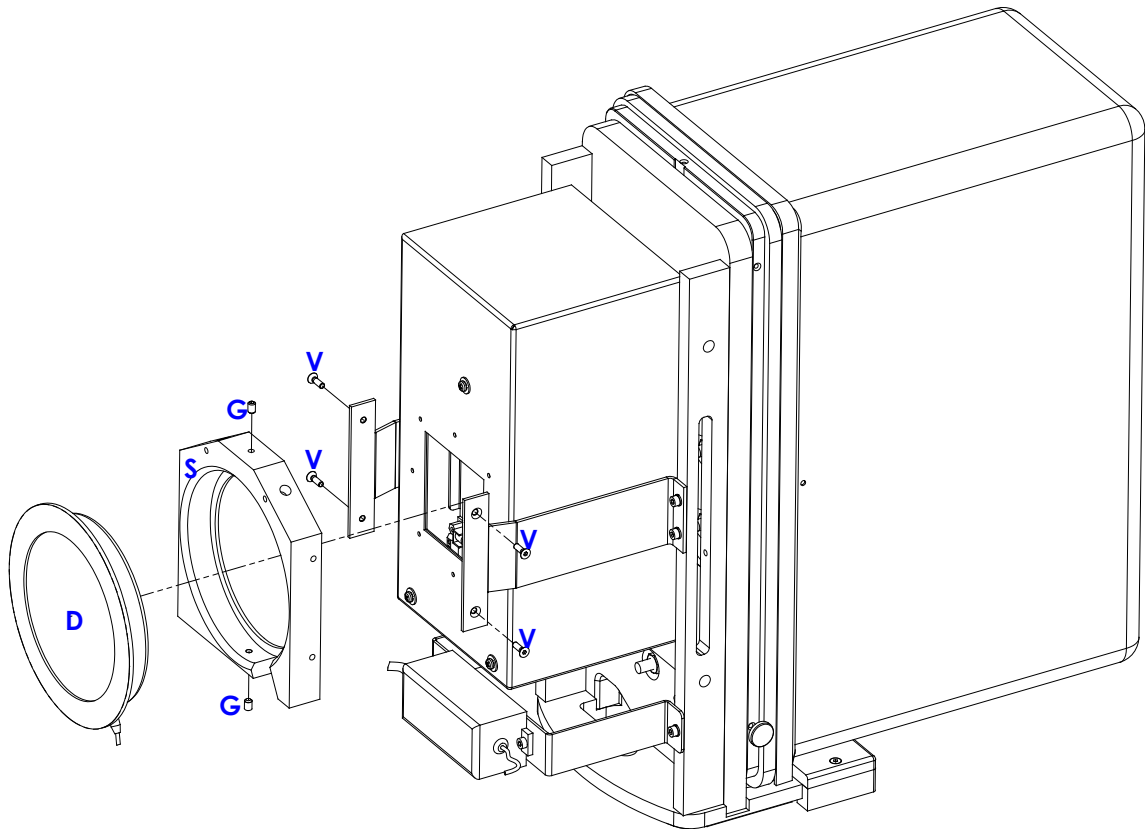

Fig. 6



Repeat the above steps in reverse order to remount the DAP.

After replacing the DAP meter, you need to check the DAP reading (see paragraph 2.1.4.1 in Part 4).

5.3 FITTING / REMOVING THE FLAT PANEL DETECTOR (FPD) COMPONENTS

5.3.1 FPD



Attention: Before removing the FPD, you **must** rest the rear section of the stand on a suitable wooden block (Fig. 7a).
You **must** also rotate the C-arm so that the **X-ray monoblock rests** on a suitably strong support (Fig.7b).

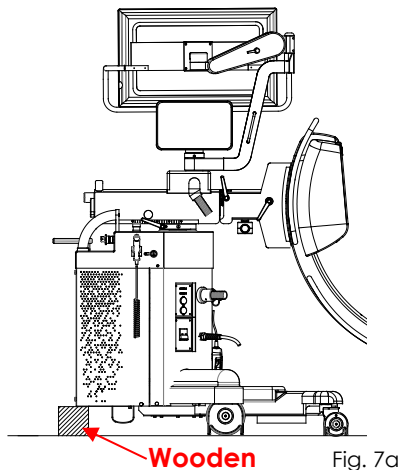

Fig. 7a

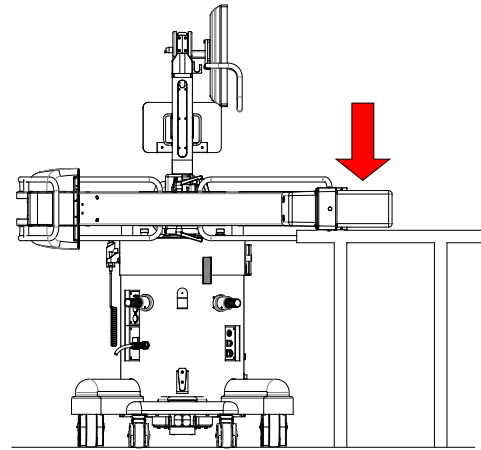

Fig. 7b

To remove the FPD (follow the same steps in reverse order to remount it, taking care not to damage any wiring):

- Remove the laser unit (see paragraph 5.3.2 below).
- Undo the 4 screws (V1) (Fig.7c) and then remove the counterweight (C) (Fig.7d).
- Disconnect all the cables.
- For 21x21 FPD version: undo the 3 screws (V2) and the 2 screws (V3) (one on either side), together with their washers (Fig.7e).
- For 30x30 FPD version: undo the 5 screws (V4) (Fig.7f) and the 2 screws (V5) (fig. 7g), together with their washers.
- Remove the FPD and its plate of support as shown in Fig.7e/ Fig. 7g). During this procedure, **maintain the FPD** in order to prevent accidental falls.
- Taking care not to damage any cables, undo the 6 screws (V6), the 4 screws (V7) and remove the FPD from the support plates (Fig.7h).

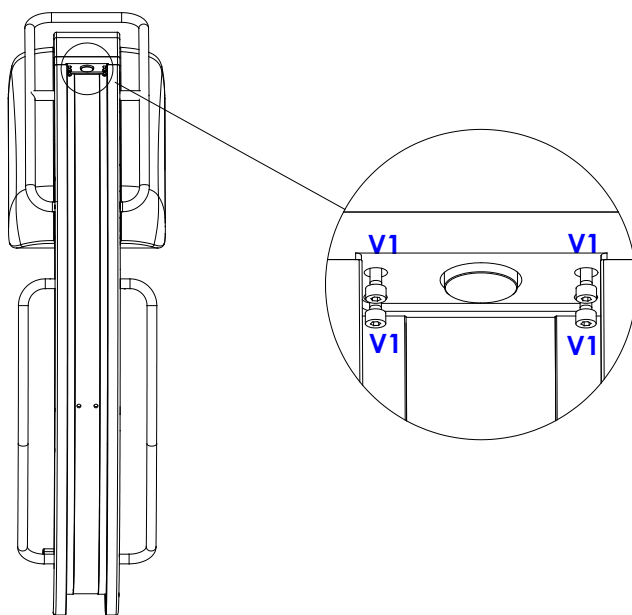

Fig. 7c

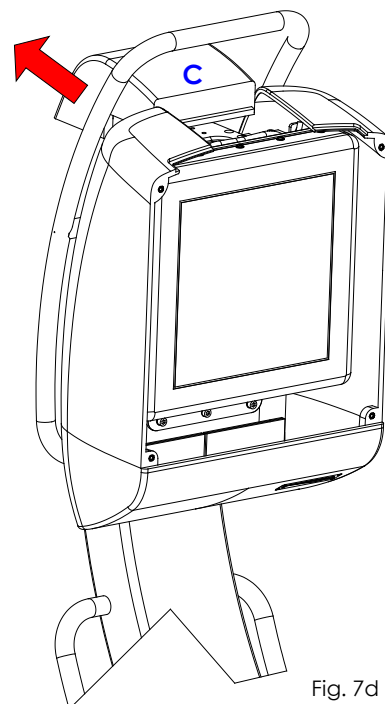

Fig. 7d

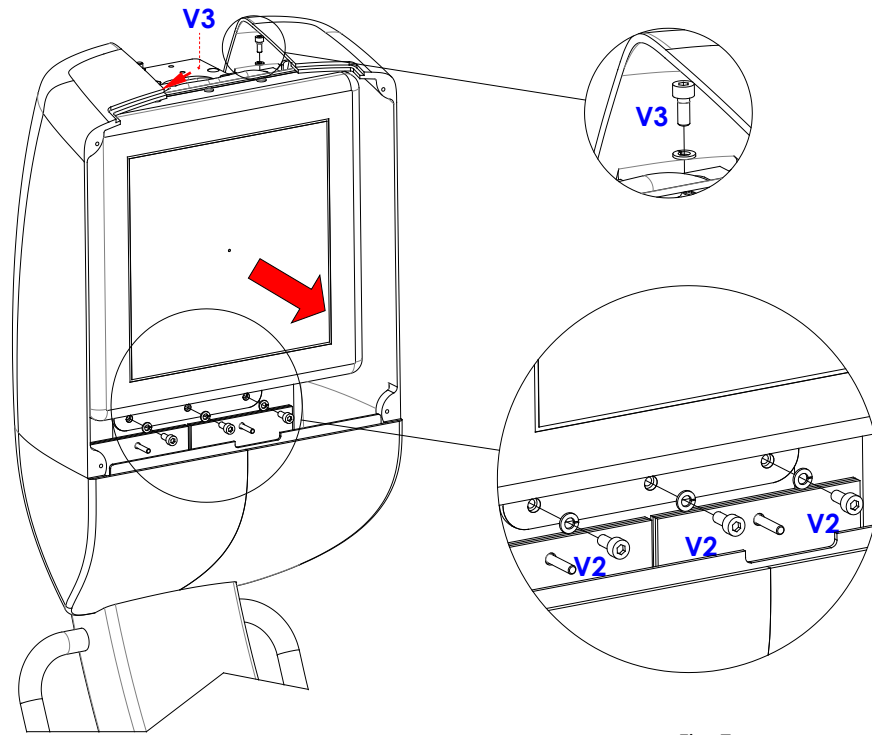

Fig. 7e

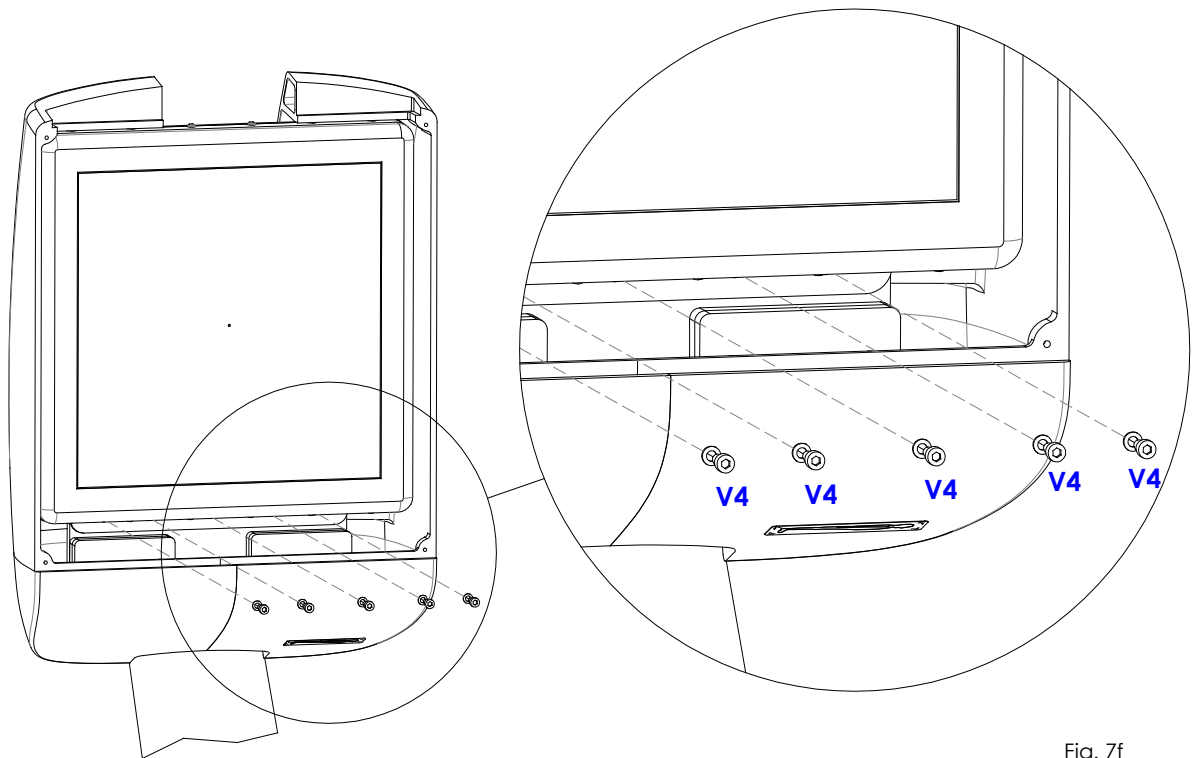

Fig. 7f

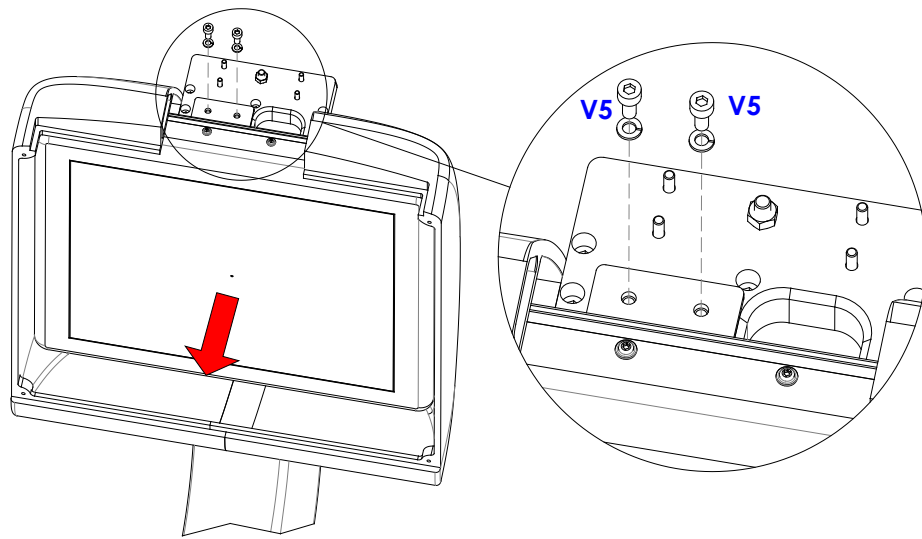

Fig. 7g

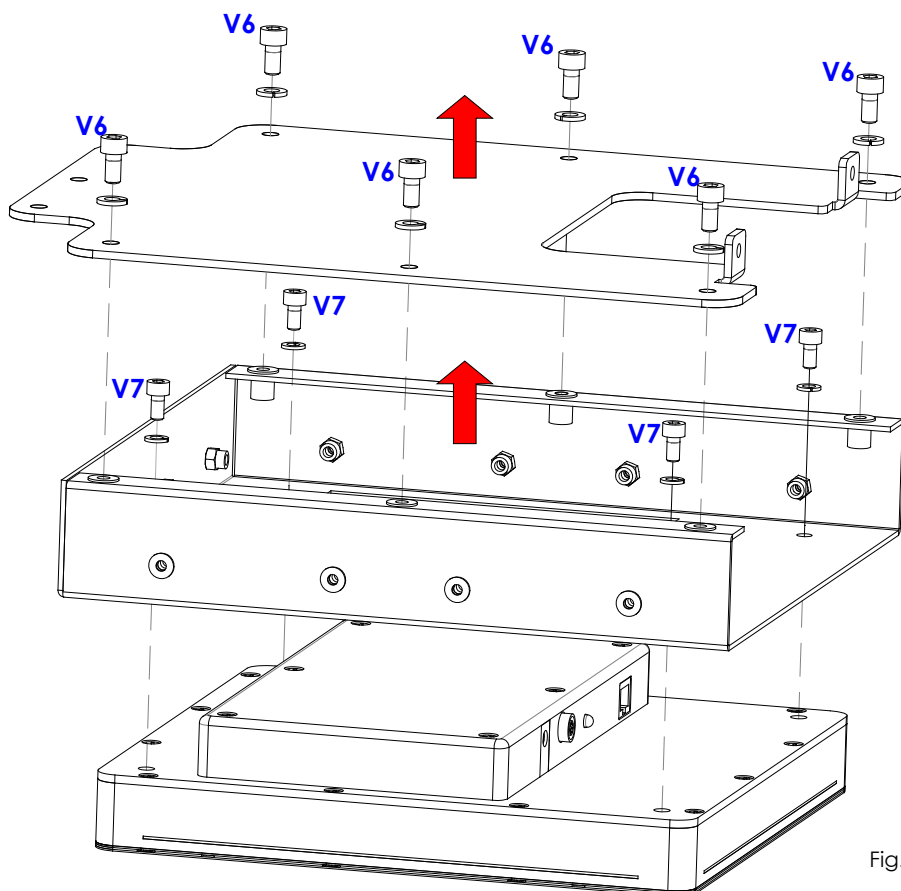

Fig. 7h

After mechanically replacing the FPD, you need to perform the following configuration operations.

- 1) Connect a USB keyboard and USB mouse to the front of the monitor unit.
- 2) Switch the equipment on and then log onto the operating system as user Admin2 (see paragraph 5.3 in Part 2).
- 3) Copy the content of the "**Receptor Installation Disc**" which is supplied with the detector on a PENDRIVE USB and connect it to one of the USB ports available on the motherboard of the video processor.



Nome	Ultima modifica	Tipo
File attualmente sul disco (12)		
00_M01x10.5pFvg215fps	4/26/2018 7:04 AM	Cartella d
01_M11x14pFvg115fps	4/26/2018 7:04 AM	Cartella d
02_M22x20.5pFvg130fps	4/26/2018 7:04 AM	Cartella d
03_M32x22pFvg130fps	4/26/2018 7:04 AM	Cartella d
Defect Maps	4/26/2018 7:04 AM	Cartella d
Receptor Firmware	4/26/2018 7:04 AM	Cartella d
Receptor Test Data	4/26/2018 7:04 AM	Cartella d
Receptor Test Summary	4/26/2018 7:04 AM	Cartella d
642509-0908_126609rD_2121DXV_standard_config.dat	4/26/2018 5:25 AM	Probe Do
autorun.inf	4/26/2018 7:04 AM	Informazi
HcpConfig.ini	4/26/2018 6:19 AM	Impostazi
Setup.exe	4/26/2018 7:04 AM	Applicazi

- 4) Launch the file **Setup.exe** and follow the installation procedure by clicking on **Next**:

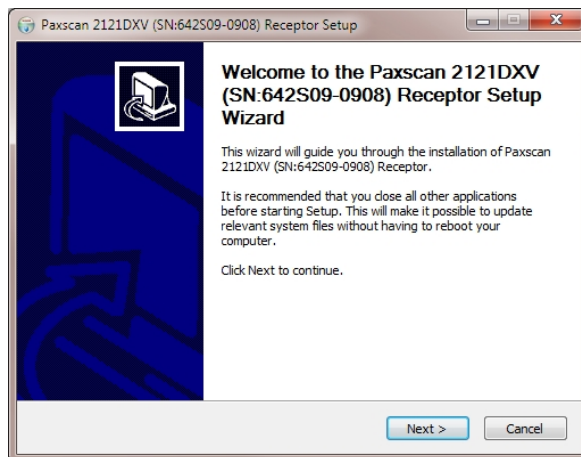

- 5) Select this same PENDRIVE as installation path:

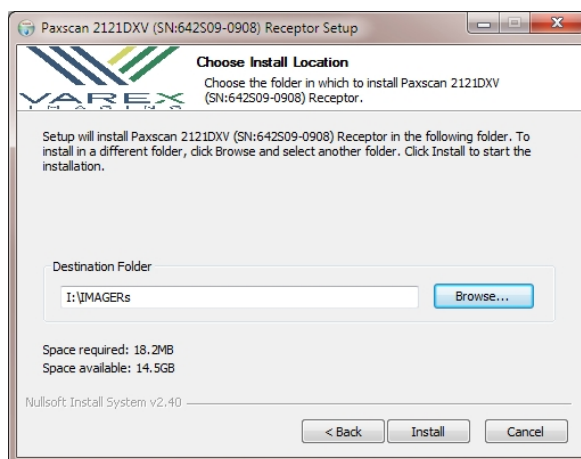

6) Press **Finish** to finalize the procedure:

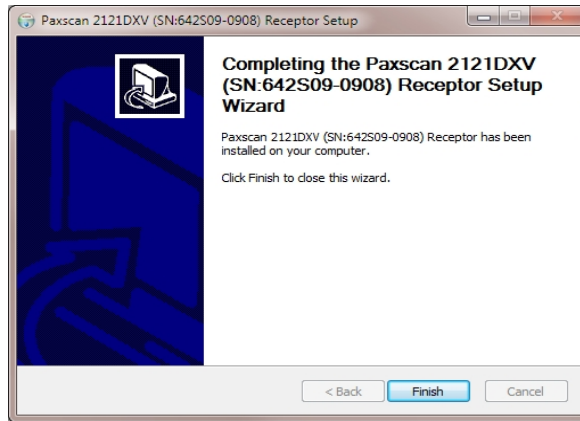

7) Access the folder: **"IMAGERS"** which has been created on the PENDRIVE and copy the folder with the FPD serial number (e.g.: **642S09-0908**) on the video processor to the archive disk on **"D:\Varex"**

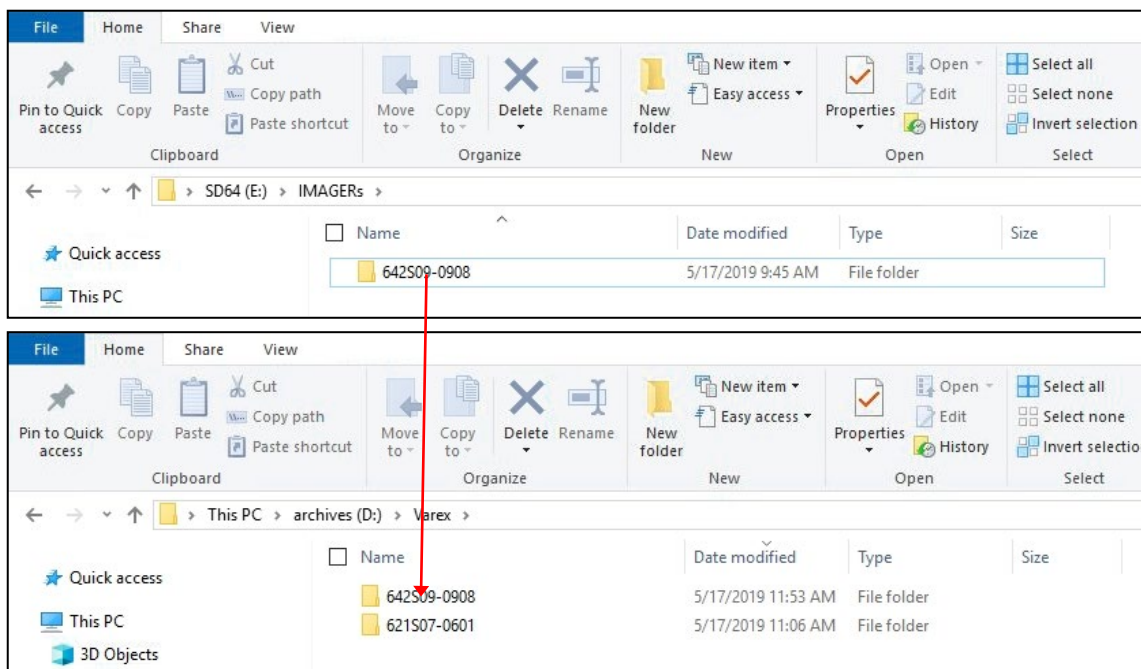

8) Launch the setup application (**ISIX Internal Setup**) which is on the desktop and enter the password "breatheme":

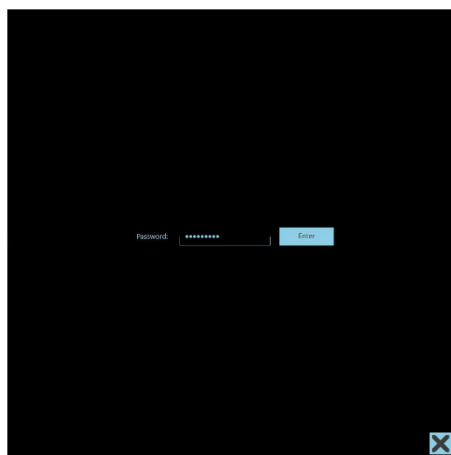

- 9) Check the serial number of the equipment and if necessary, modify it by entering the correct number and press the first key SET.
Select the detector type you wish to install (e.g.: **VAREX PaxScan 2121DXV**), enter its serial number (e.g.: **642S09-0908**) and press the 2nd key SET.

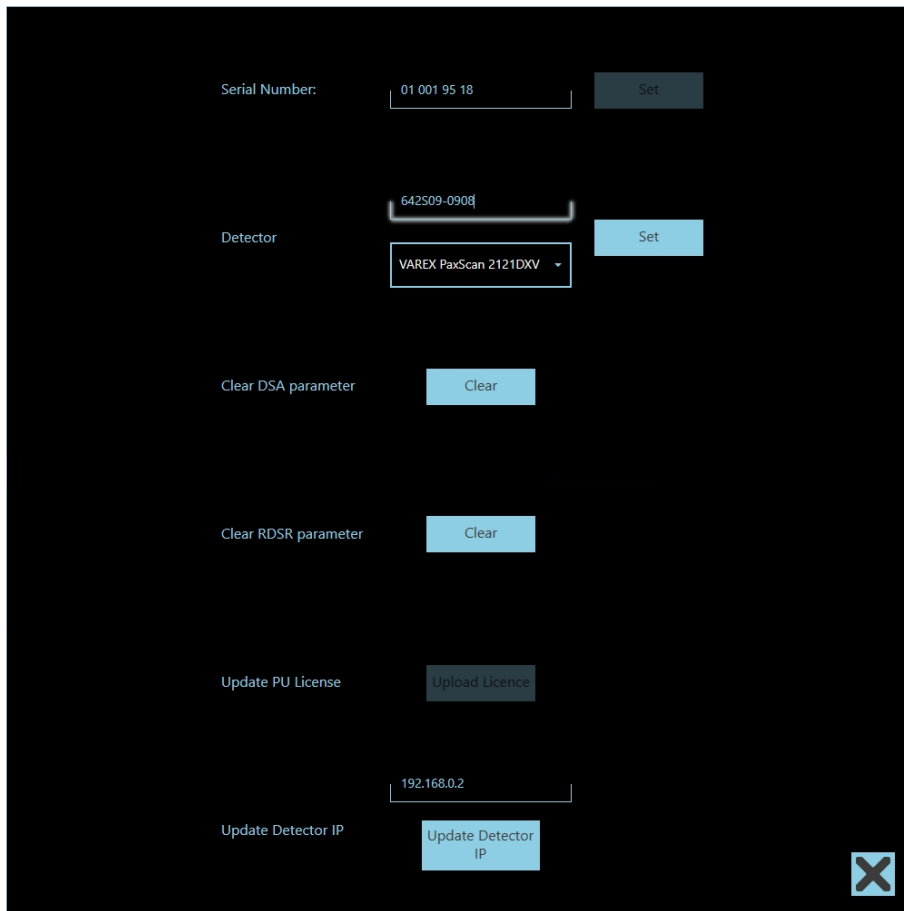

- 10) Once the following indication will be shown: "DB files updated correctly, restart the machine" you can close the setup application and you will need to proceed with the calibration of the detector as described in PART 4, para. 3 of the present manual.

5.3.2 LASER / ANTI SCATTERED GRID UNIT

To remove the laser / grid unit:

- Unscrew the 4 screws (V).
- Remove the panel (P) in the direction shown by the arrow in Fig.8.
- Disconnect the laser cables and the anti-scattered grid cables so that you can detach the panel (P).

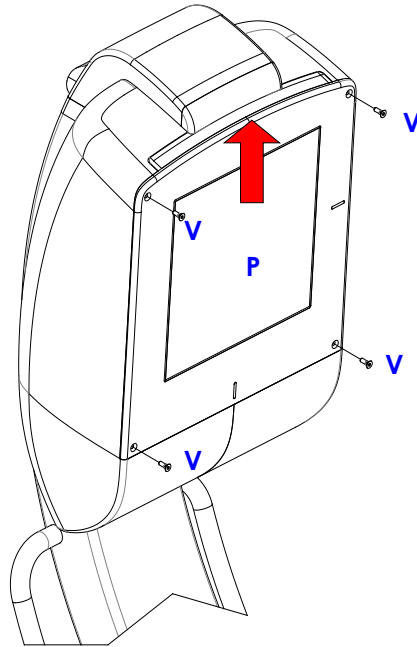

Fig. 8a



Repeat the above steps in reverse order to remount the unit.

5.4 FITTING / REMOVING THE STAND COMPONENTS

5.4.1 PARKING BRAKES

If the braking system should fail, check the state of the brake pads "P" on the 2 side wheels. If necessary, follow the steps below to replace the pads:

- Remove the cover on the leg of the stand (see paragraph 5.4.2 below).
- Raise the leg slightly so you can place a block of wood under this, lifting the wheel from the ground (at least 2 men should be used to do this).
- Remove the 2 screws (V) and their washers (R) fixing the hub caps (C); then remove the covers.
- Remove the nut (D) and extract the pin (P) from the wheel.
- Extract the wheel (A).
- Extract the pin (S) fixing the pad (B) and then remove the pad itself.
- Insert a new pad and then repeat the above steps in reverse order.

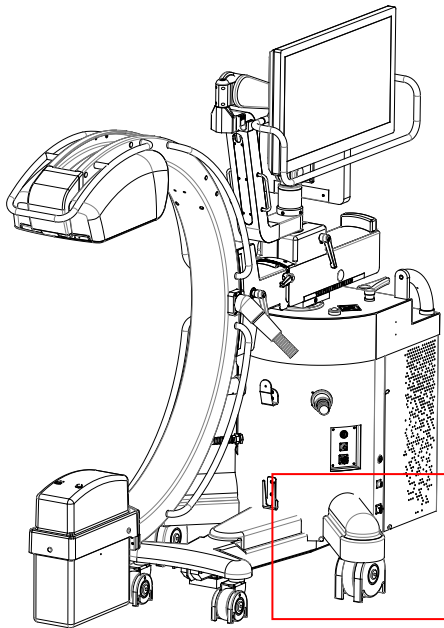

Fig. 9a

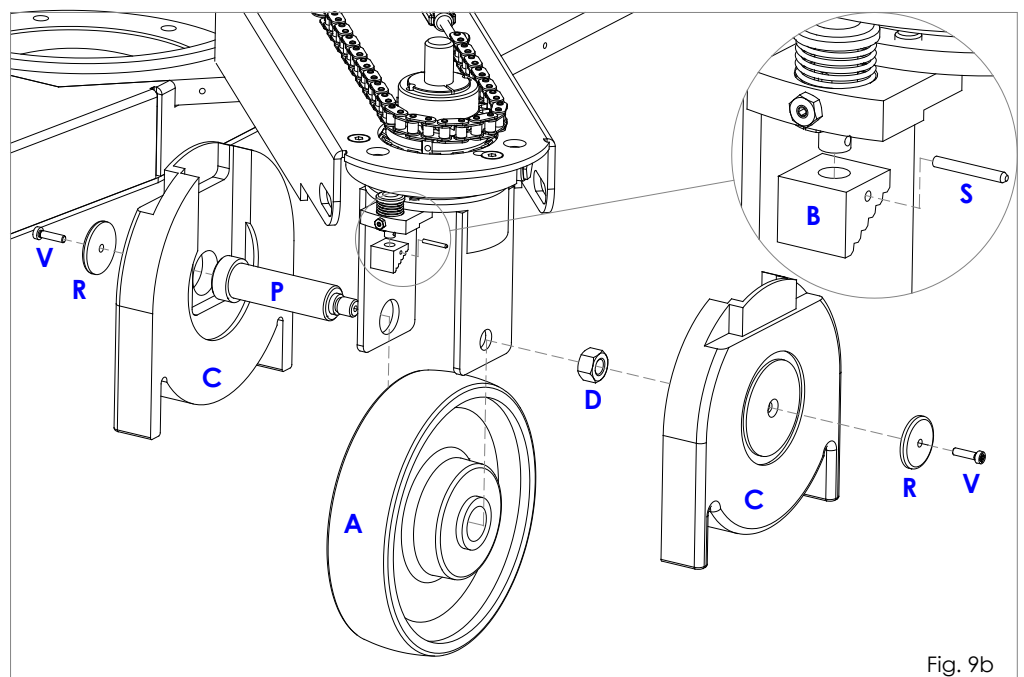

Fig. 9b

5.4.2 STAND WHEEL ROTATION CHAINS

a) **To restore the correct tension of the lower chains** responsible for rotating the rear wheels:
Carry out the following operations:

- Remove the cover on the leg (C2) by undoing the 2 screws (V) and their washers (under the leg).



For better access to tie-rods (T), you can also remove the rear stand cover (C1) (see paragraph 5.1.3 above).

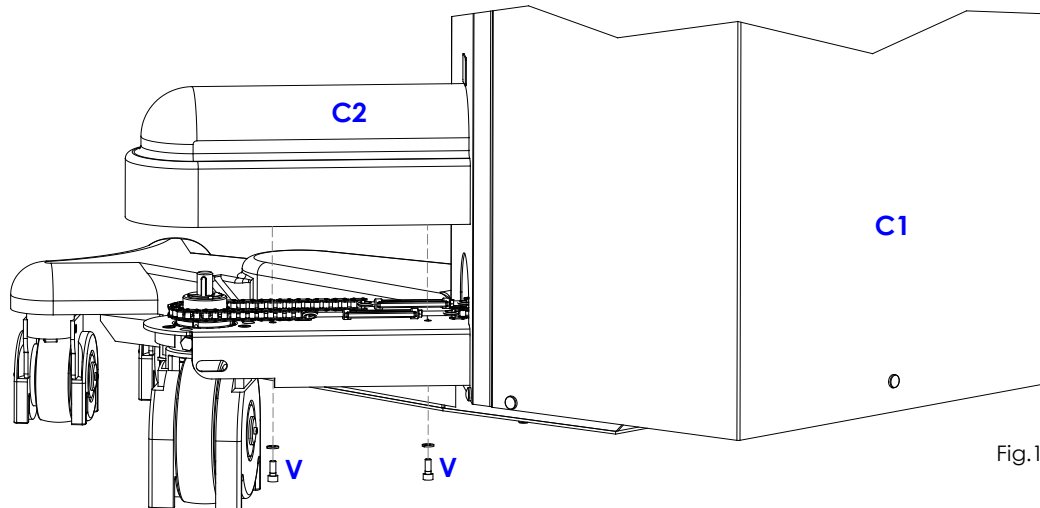

Fig.10

- Loosen the counter-nut (D) and tension the chain using tie-rod (T).



Attention: To avoid altering the direction of the wheels, you should repeat this operation symmetrically on both tie-rods.

- Tighten the counter-nut (D).
- Check the movement of the chain by using the steering handle on the console.
- Finally, reinstall the stand cover and leg covers.

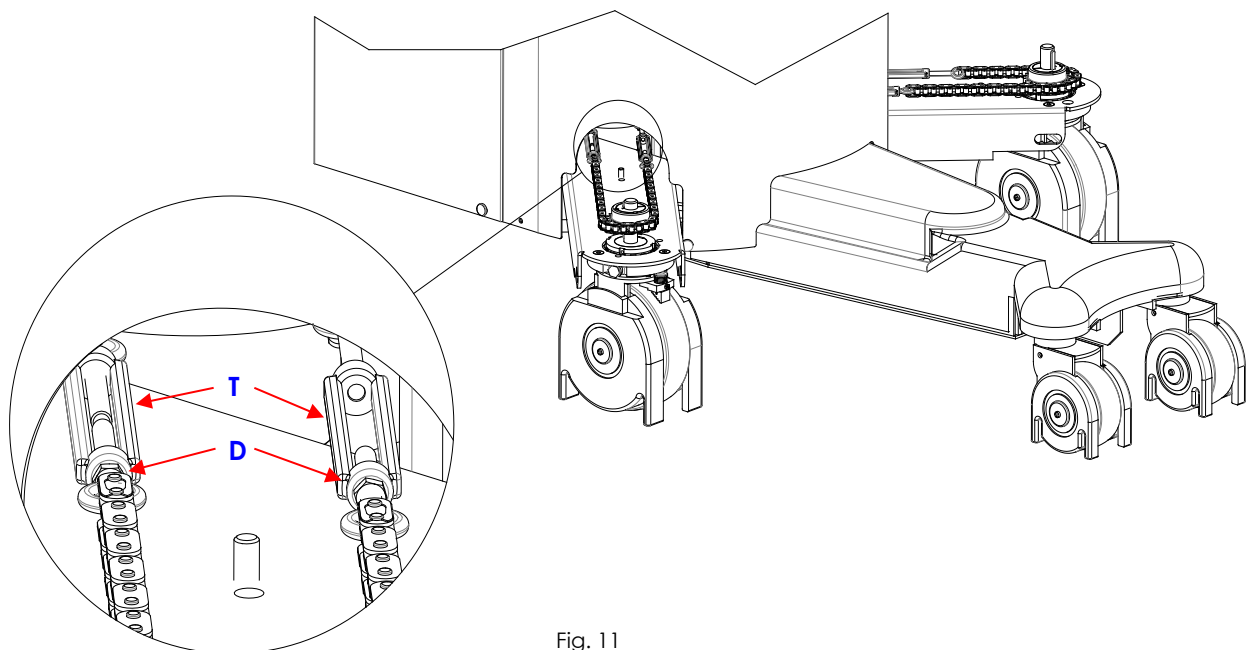

Fig. 11



Instructions valid for both chains.

b) To remove and replace **the upper chain** responsible for rotating the wheels, carry out the following operations:

- Remove the rear cover on the stand (see paragraph 5.1.3 above).
- Unscrew the tie-rod (T) and extract the chain to be replaced.
- Insert the new chain, connect it to the tie-rod and tighten to get the right tension.
- Check the system works correctly using steering knob (M).
- Reinstall the cover.

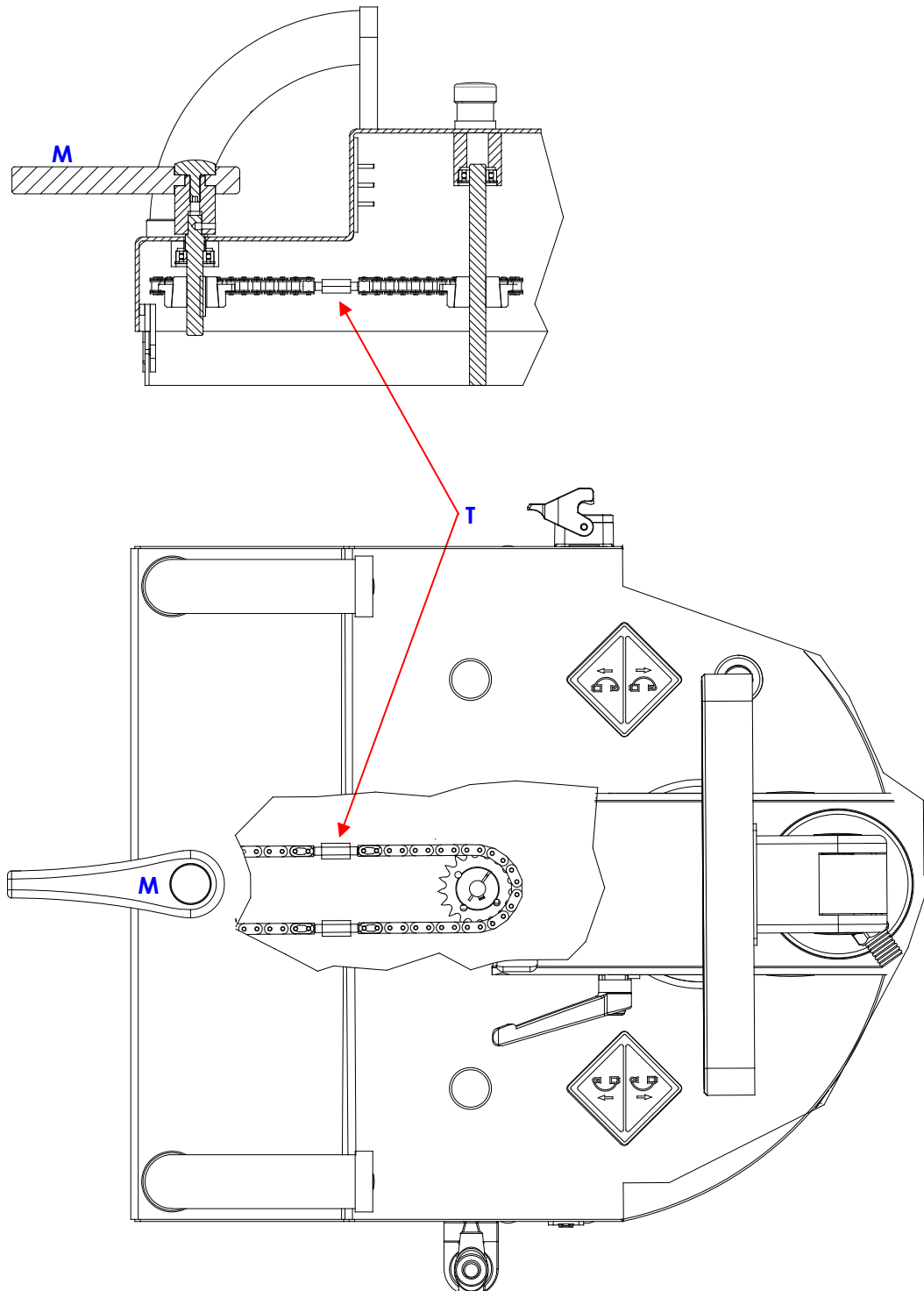

Fig. 12

5.4.3 ADJUSTING THE C-ARM BEARINGS

- If the C-arm does not move smoothly, you need to adjust the trolley bearings:
Remove the 8 plugs (T), using a small flat screw-driver in order to access the lateral and front bearings through the holes (F1), (F2), (F3) and (F4).

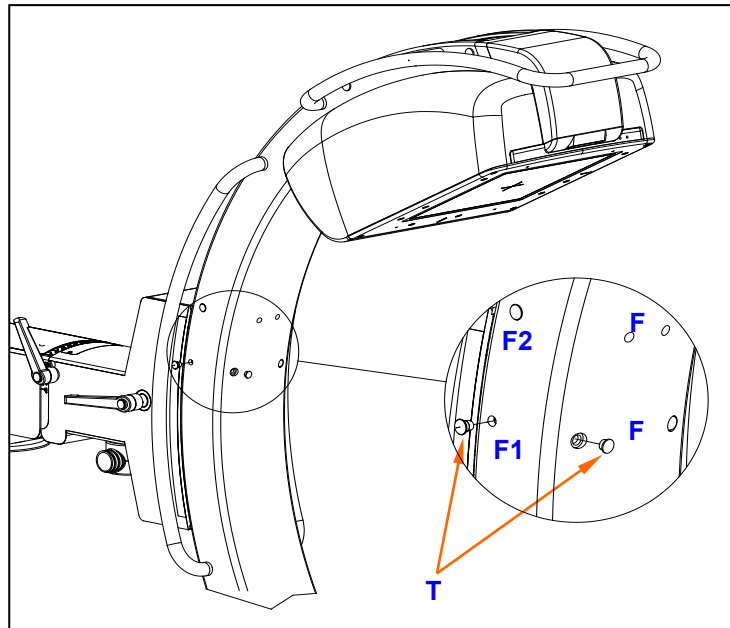

Fig. 13

a) Adjusting the front bearings "C1":

- Take the C-arm to the position shown in Fig.14 in order to align one of the holes (F4) with the eccentric pin on one of the bearings (C1), while the holes (F1) are lined up with the grub screws locking the pins.
- Using a 2.5 mm Allen key in the hole (F1), loosen the grub screw (G1) on the eccentric pin (P1). Adjust the play of the bearing by using a 5 mm Allen key in the hole (F4).
- Fix the position of the bearing by tightening the grub screw (G1).

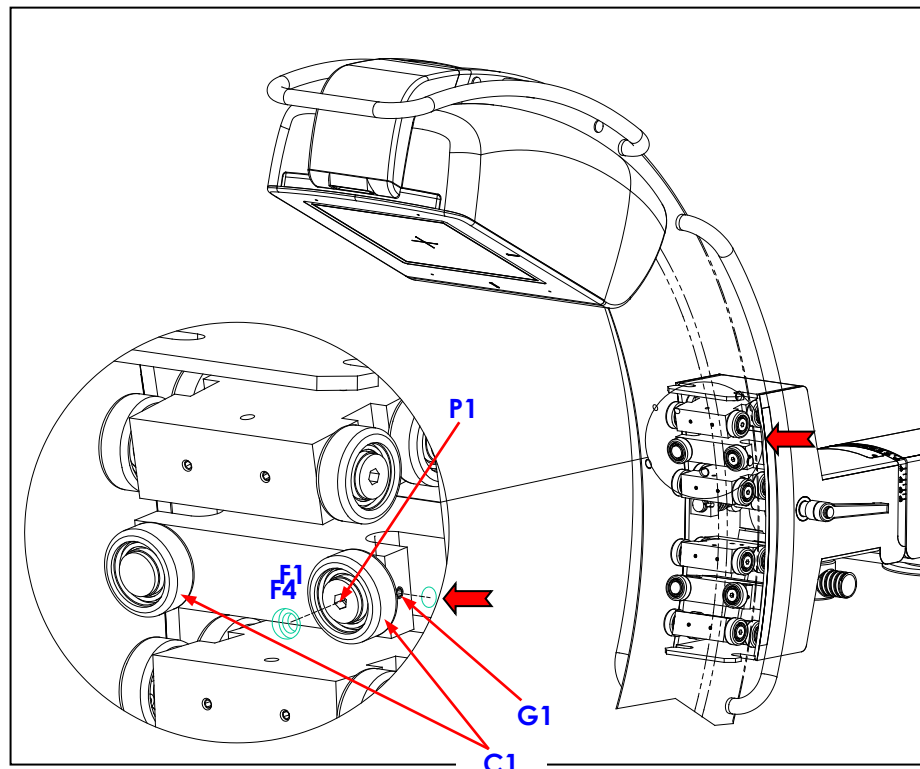

Fig. 14

b) *Adjusting the front bearings "C2":*

- Take the C-arm to the position shown in Fig.15 in order to align one of the holes (F4) with the eccentric pin on one of the bearings (C2).
- Adjust the play as explained above for bearings (C1).

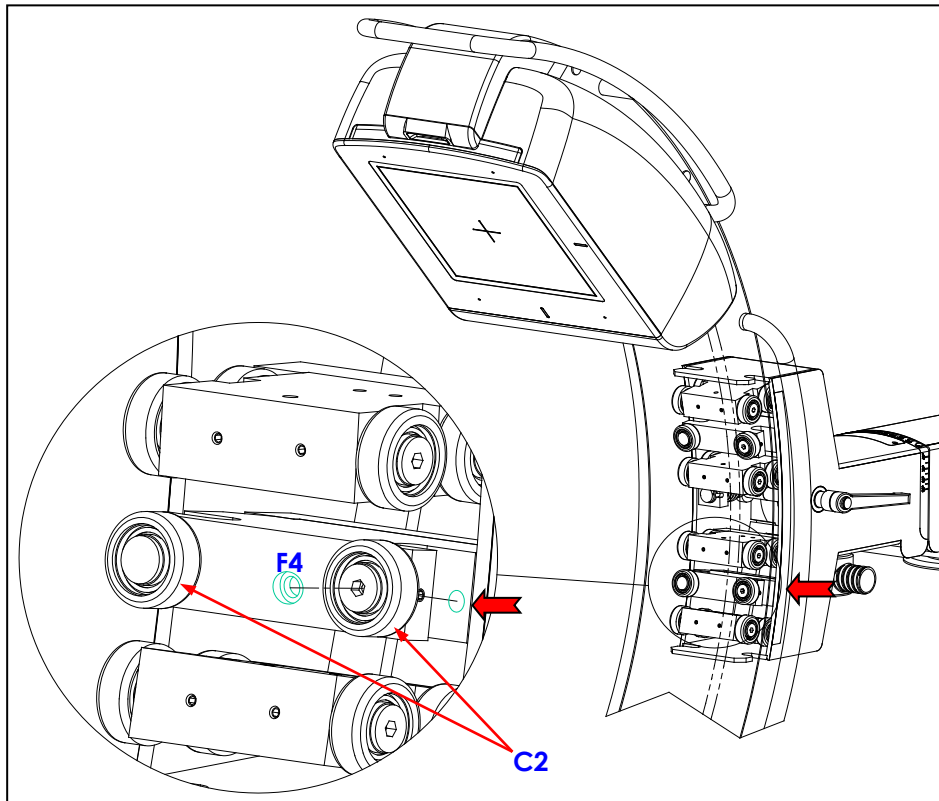

Fig. 15

c) *Adjusting the lateral bearings "C3":*

- Take the C-arm to the position shown in Fig.16a in order to align the hole (F2) with the eccentric pin on the bearing (C3), while the holes (F3) are lined up with the grub screws (G3) locking the pins.
- Using a 2.5 mm Allen key in the hole (F3), loosen the grub screw (G3) on the eccentric pin (P3). Adjust the play of the bearing by using a 5 mm Allen key in the hole (F2).
- Fix the position of the bearing by tightening the grub screw (G3).

Note: Repeat for both the bearings (C3)

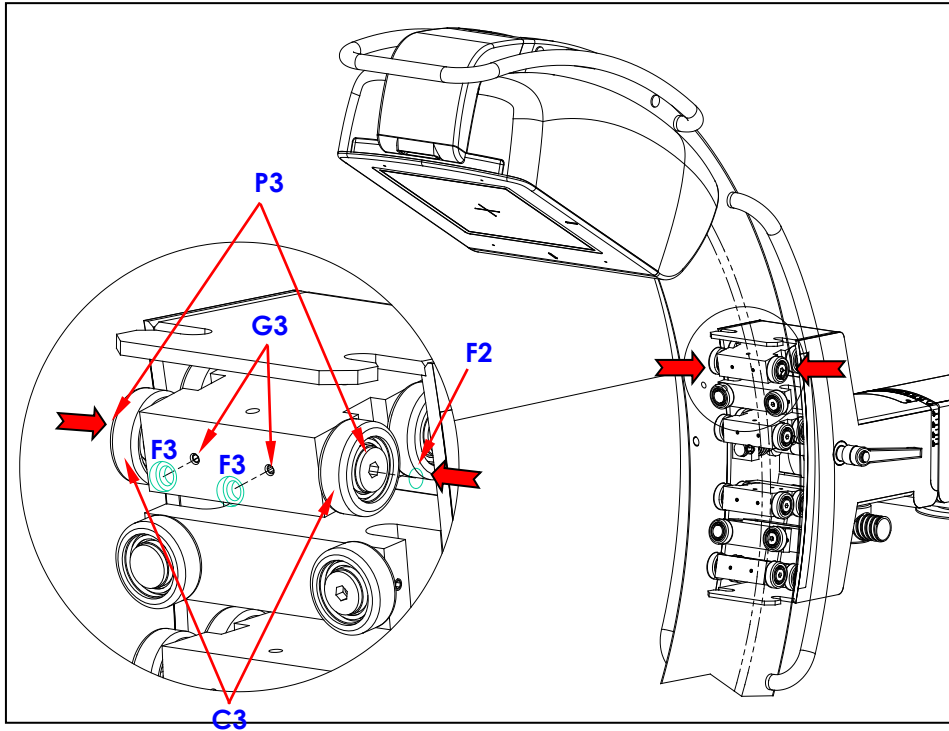

Fig. 16a

d) Repeat the steps in part c) above for all the other pairs of bearings (C4), (C5) and (C6) (see Fig.16b).

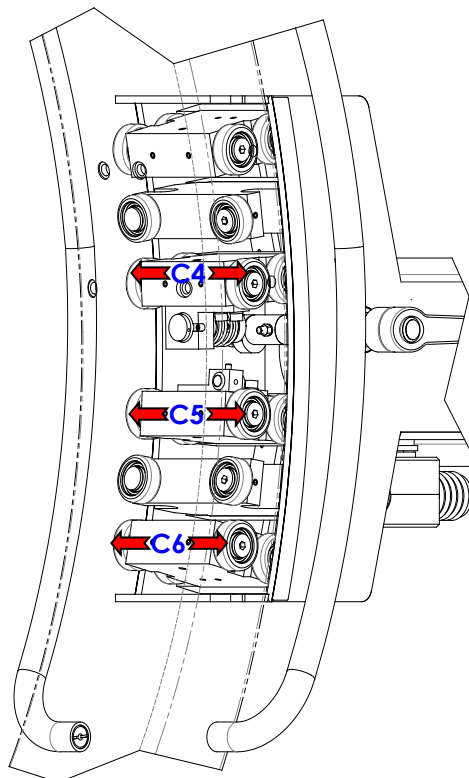

Fig. 16b

5.4.4 REPLACING THE VIDEO PROCESSOR

- Remove the stand cover (see paragraph 5.1.3 of the present chapter).

Replace the video processor (A) as follows:

- Disconnect the cables connected video processor.
- Unscrew the 3 screws and the associated washers (V).

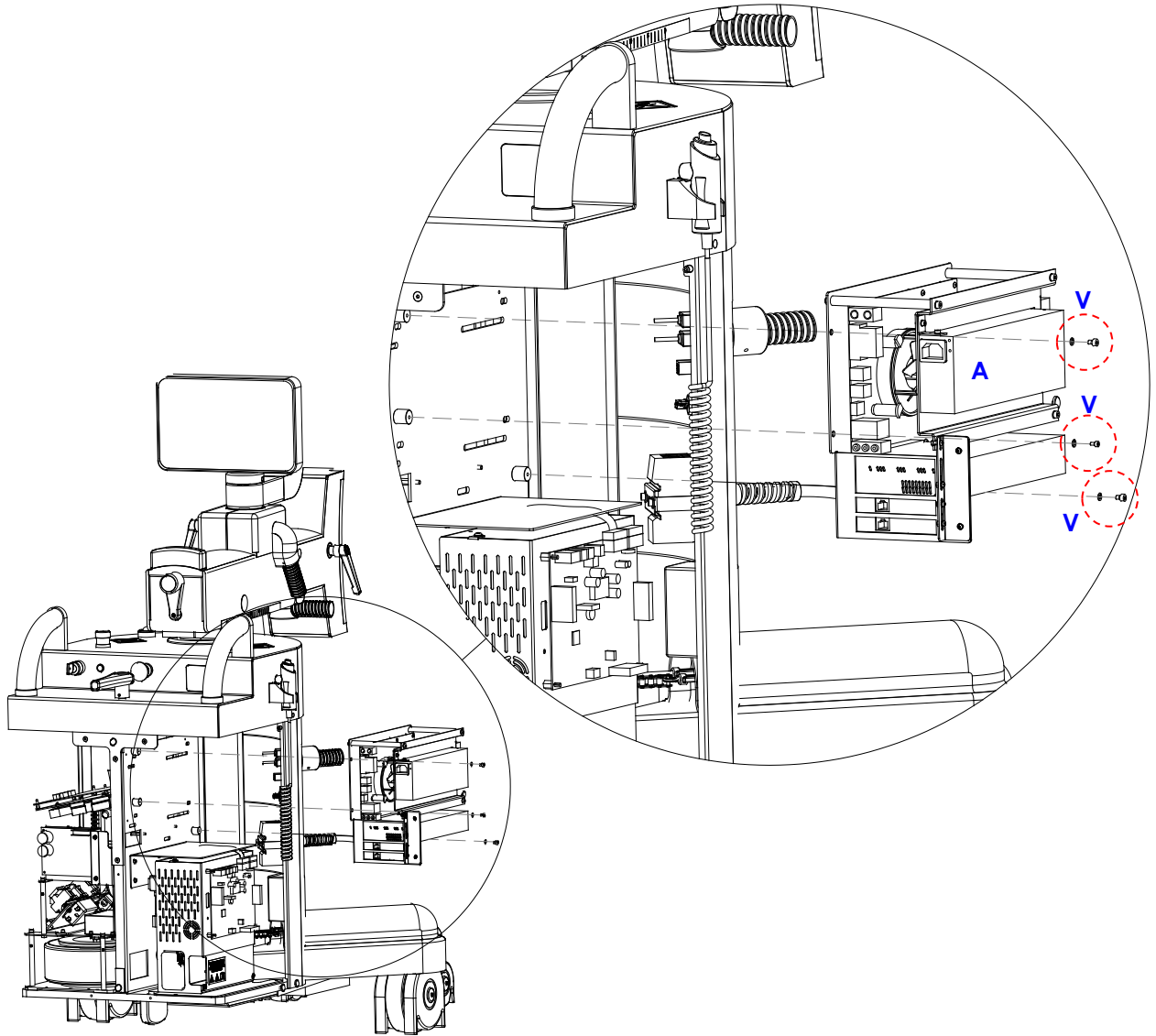

5.4.5 REPLACING BOARDS CTBK-HW AND ASAC 01

- Remove the cover on the stand (see paragraph 5.1.3 above).

To replace board CTBK-HW (A):

- Disconnect the cables connected to the board.
- Undo the 7 screws (V1).

To replace board ASAC 01 (B):

- Disconnect the cables connected to the board.
- Undo the 4 screws (V2).

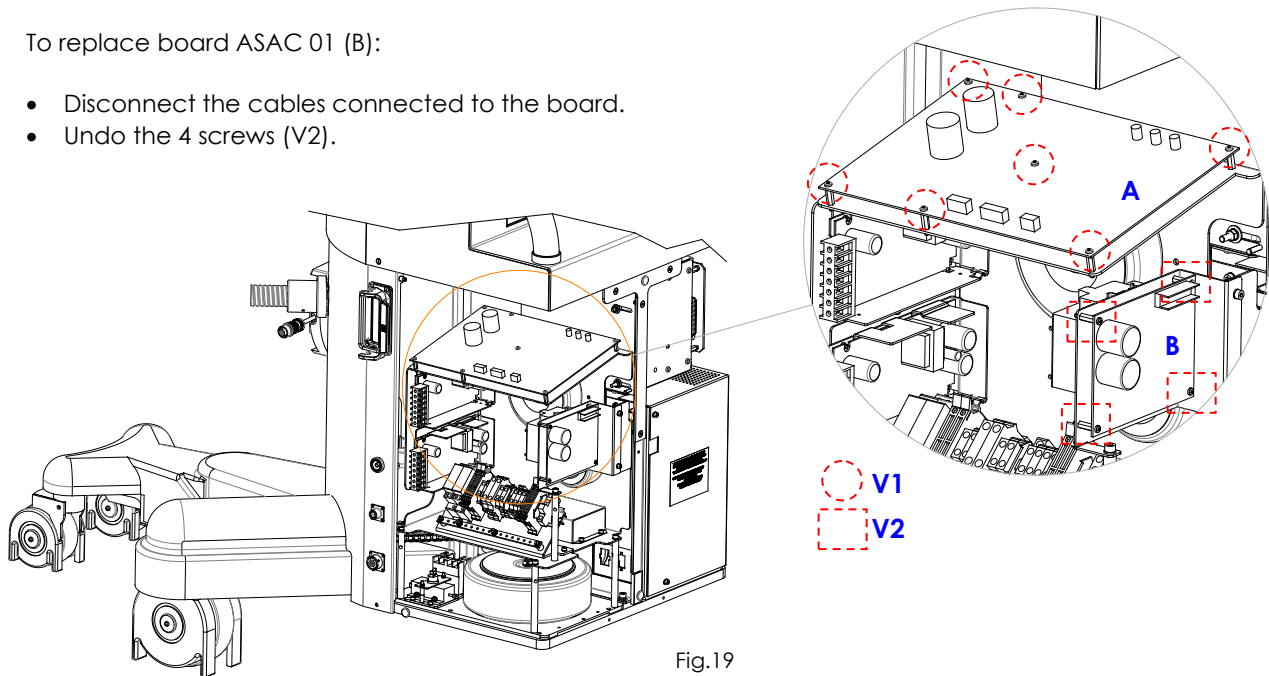

Fig.19



Follow the above steps in reverse order to remount the boards.



Note: After replacing board ASAC 01, check the up/down speed of column and the max limits.

5.4.6 REPLACING THE CONTROL PANEL (PC PANEL)

To remove the control panel:

- Undo the 2 screws (V1) and remove the rear cover (A).
- Disconnect all the cables.
- Undo the 4 screws (V2) and extract the control panel (B).

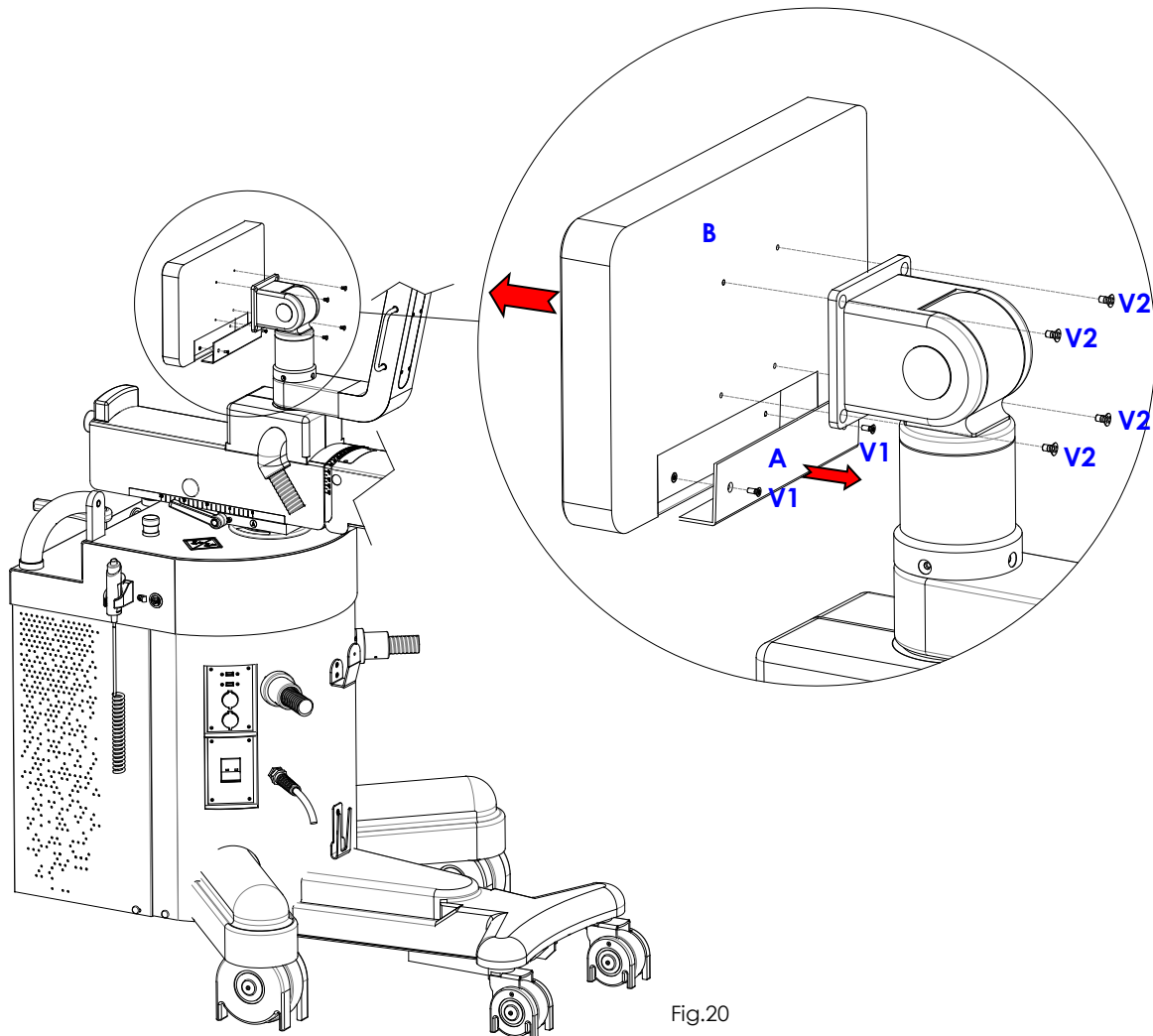

Fig.20



Repeat the above steps in reverse order to remount the Control Panel.



Make sure that the software release (SystemA DRF) installed on the new control panel is the same as that used on the video processor. If not, you will need to upgrade the software, as described in Part 5, paragraph 2.4.2 of this manual.

5.4.7 REPLACING THE INVERTER

- Remove the stand cover (see paragraph 5.1.3 of the present chapter).

Remove the inverter (A) as follows:

- Disconnect the cables connected to the inverter.
- Unscrew the 2 screw (V1) fixing the inverter plate (A) to the stand.
- Unscrew the 4 screws (V2) fixing the inverter (B) to the plate (A).

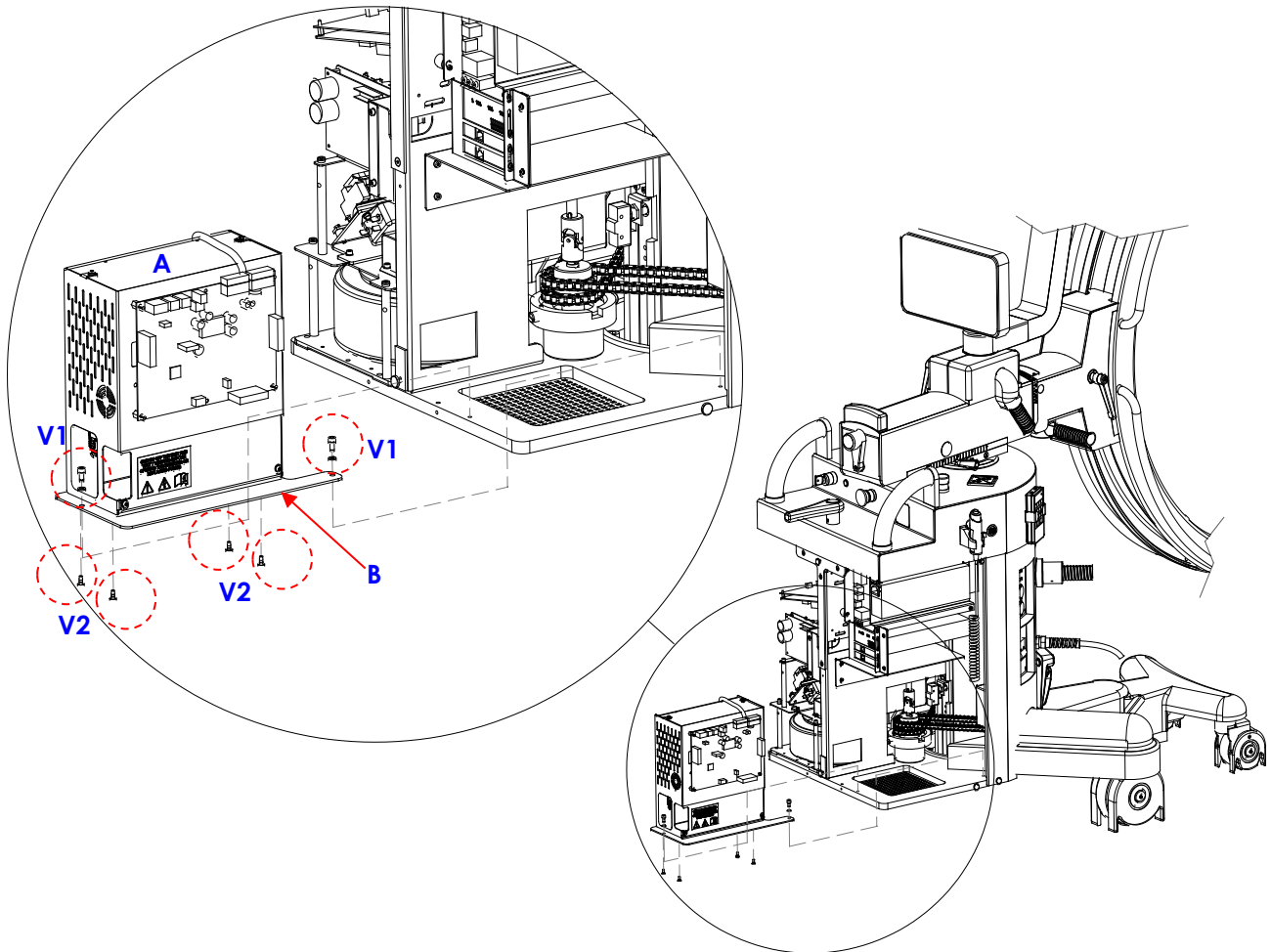

5.4.8 REPLACING THE MAIN POWER CABLE

The main power cable may become worn or damaged with use, with evident signs of cuts or scratches. Only authorized technical service personnel are permitted to replace this should the need arise.

Cable characteristics are:

- Length 8m
- Form 2 conductors (blue or brown) + earth (yellow/green) cross-section 3 x 2.5mm²
- Sheath color Grey
- Outside diameter 10mm
- Mix PVC

The new cable must be requested directly from the manufacturer, indicating code **cod. 550 95 005**.

Follow these steps to ensure that the new cable is correctly connected and fixed:



Switch the EM equipment off and unplug from the mains.

- Access the interior of the stand by removing the cover as described in para. 5.1.3.
- Unscrew the 2 screws that fix the inverter plate to the stand (see previous paragraph) so that the inverter can be taken out without needing to disconnect the cables and in order to access the remote switch.
- Remove the screw (**V1**) fixing the blue eyelet terminal of the ground conductor (yellow/green wire) from the power supply cable on the main grounding terminal GP1:

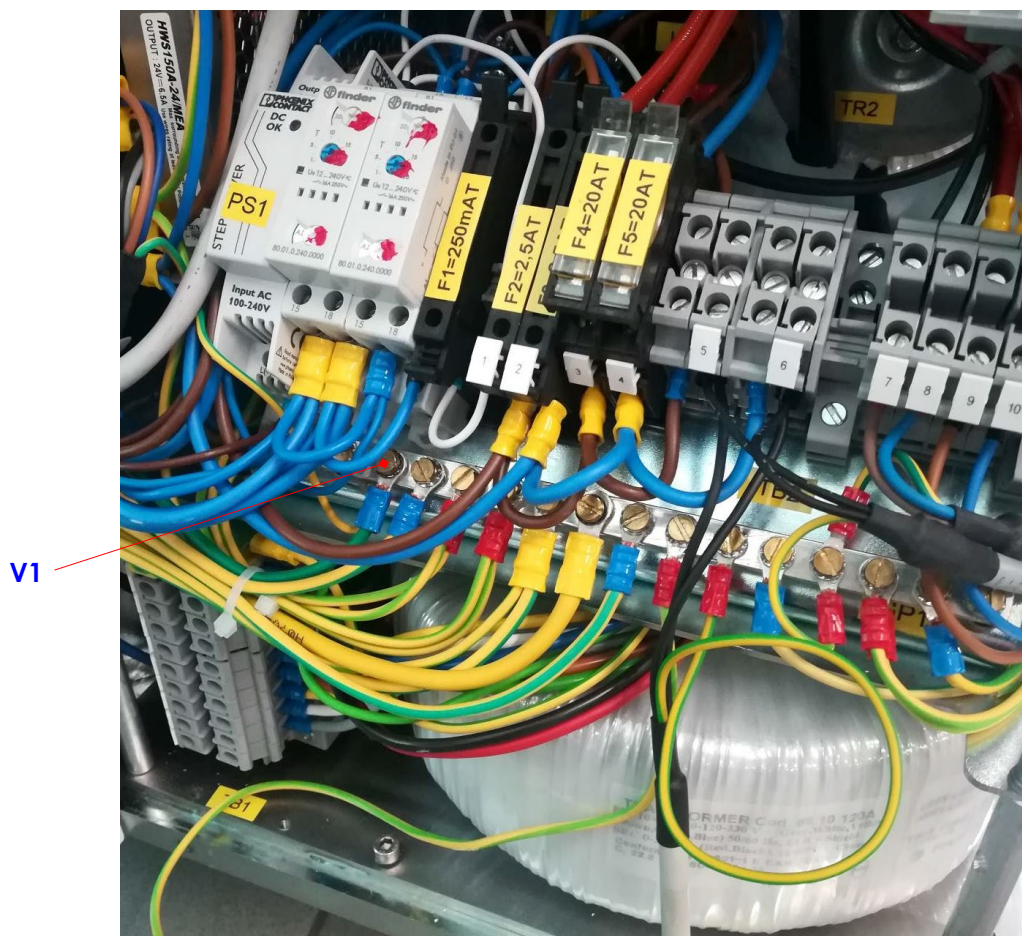

- Unscrew the 2 screws (**V2**) fixing the remote switch to the interior of the stand:

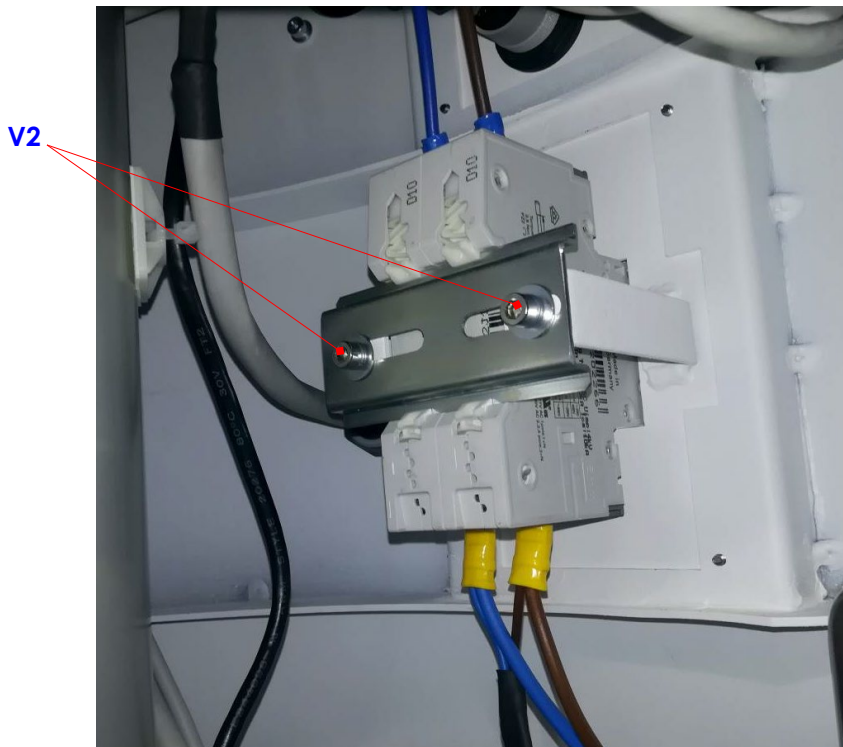

- Loosen the 2 screws (**V3**) and remove the 2 blue terminals (**P**) of the 2 power wires (blue and brown wires):

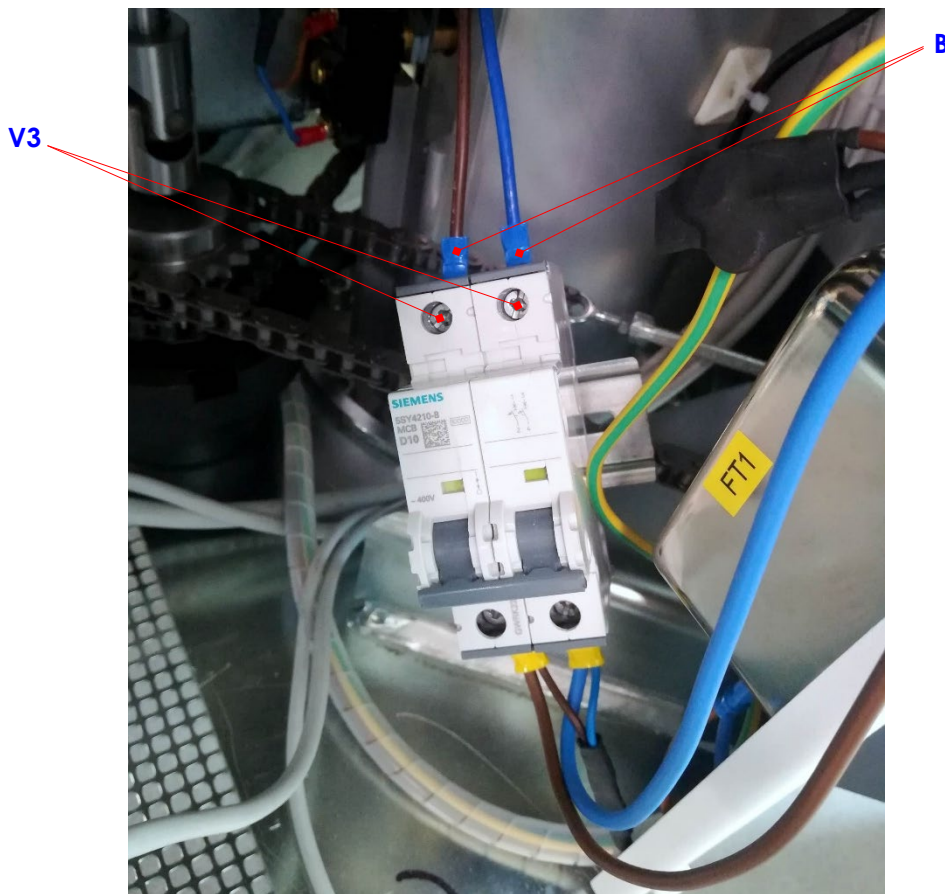

- Unscrew the cable ring nut (**G**) and extract the cable you want to replace from the stand:

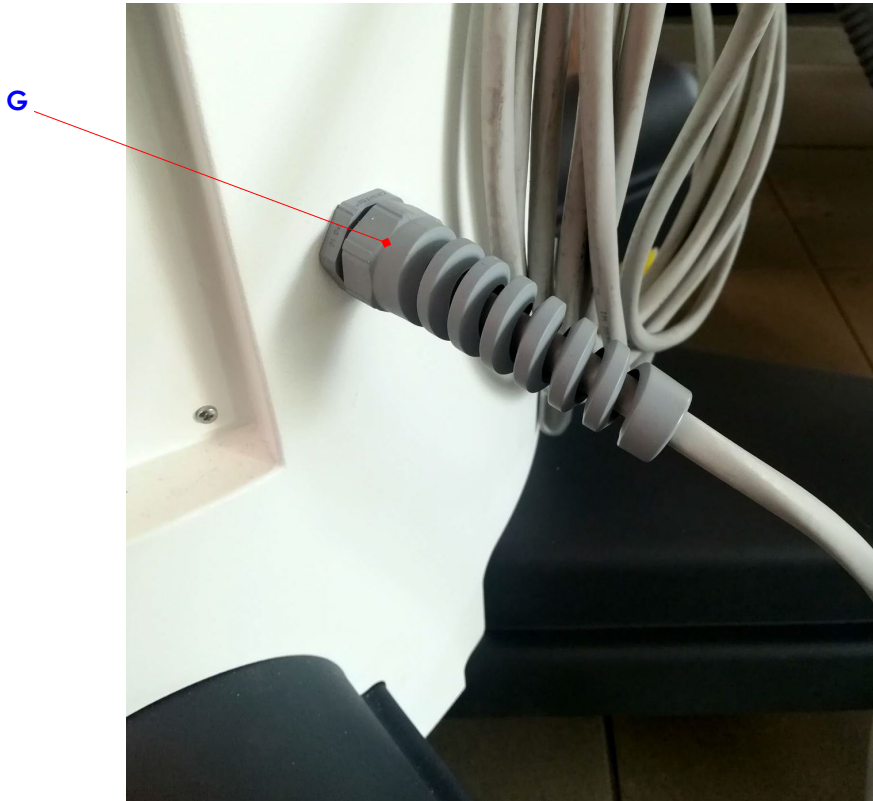

- Repeat the above steps in the reverse order to fit and secure the new original cable **cod. 550 95 005** supplied by the manufacturer.

6 ANNEXES

6.1 CREATING A BACK-UP DISK FOR THE VIDEO PROCESSOR

We recommend creating a backup (image file) of the video processor system hard disk after every important software upgrade or after changes to the system settings (e.g. DICOM settings, network settings).

The video processor has two hard disks:

The **System (C:)** disk contains the files for the operating system and the installed applications. Furthermore, it contains the calibration files for:

- X-ray generator
- X-ray collimator

The **Archives (D:)** disk contains the database which holds:

- Patient data
- DICOM settings
- Exam settings
- Acquired images

The USB pen drive on which the backup has to be stored is found inside the stand, attached to the video processor group (see next photo).

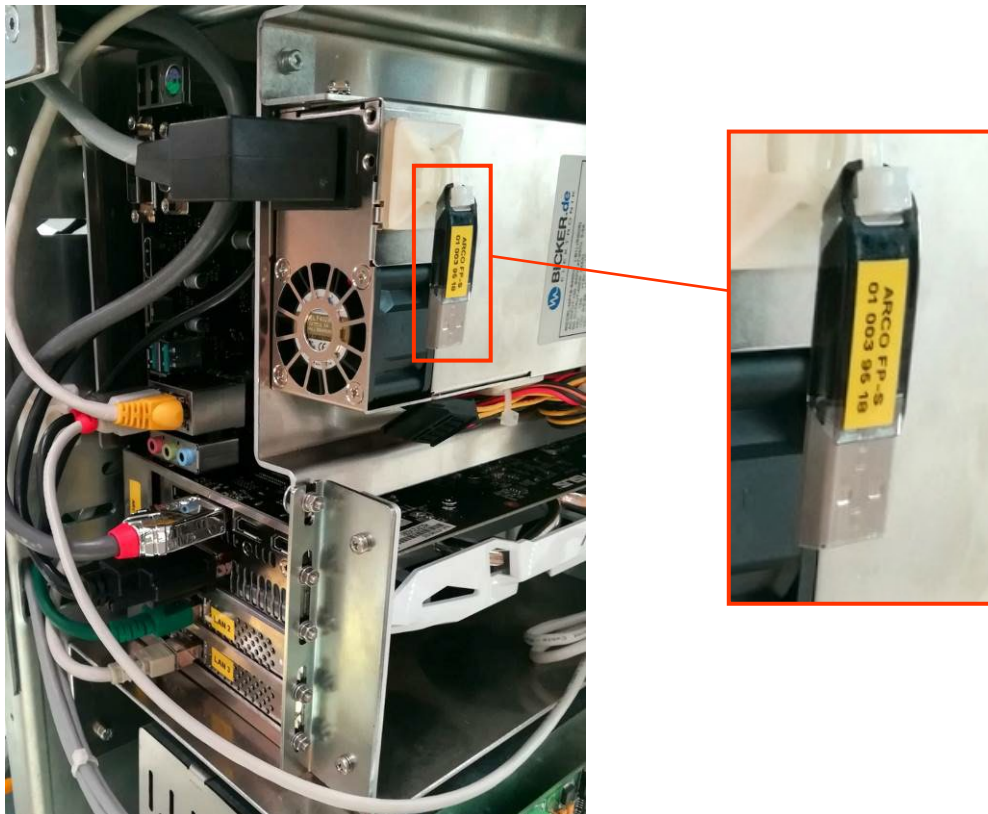

To make a backup, please proceed as follows:

- 1) Access the video processor group by removing the cover of the stand (see instructions in para. 5.1.3 of this section in the present manual).
- 2) Remove the USB pen drive shown in the photo above and connect it to one of the USB ports present on the motherboard of the video processor.

- 3) Connect a USB keyboard and mouse to the USB ports (CB5, CB6) on the stand.
- 4) Exit the SystemA DRF application and then access the video processor as "Administrator" (see paragraph 5.3 in Part 2 of this manual).
- 5) From the desktop, launch the **Macrium Reflect** application:



- 6) In the main screen (TAB "**Backup**") click on "**Image this disk...**":

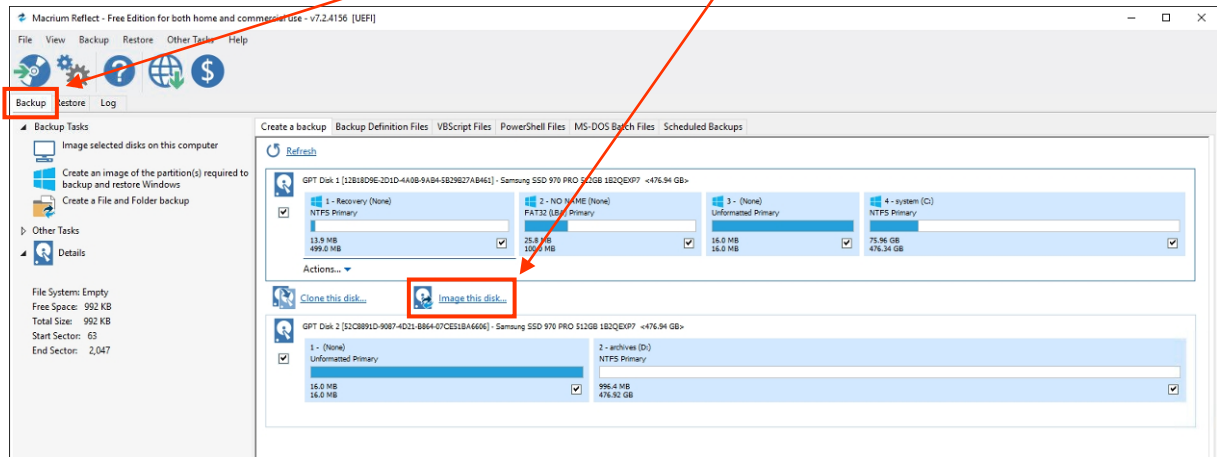

- 7) The screen **Disk Image** will be displayed. Check that:
 - in the frame "**Source**" all 4 partitions are selected which make up the system disk
 - in the frame "**Destination**" the path of the USB pen drive is correct: "**E:\Backup VP**"
 Then select the command "**Next**":

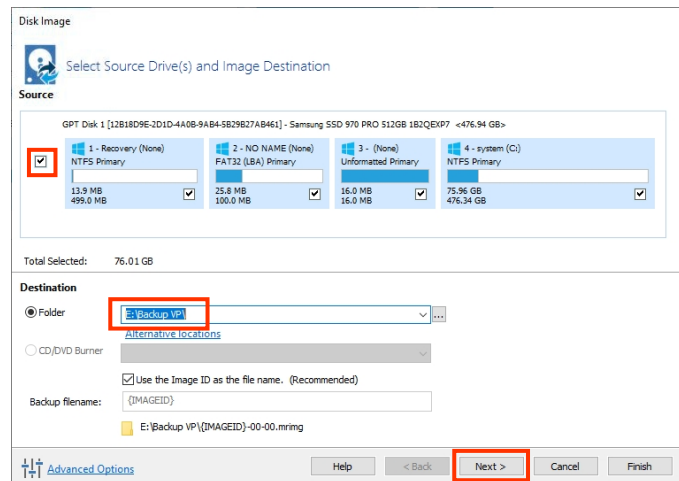

- 8) In the next screen, check that the settings correspond to those in the following image
Then select the command **“Next”**:

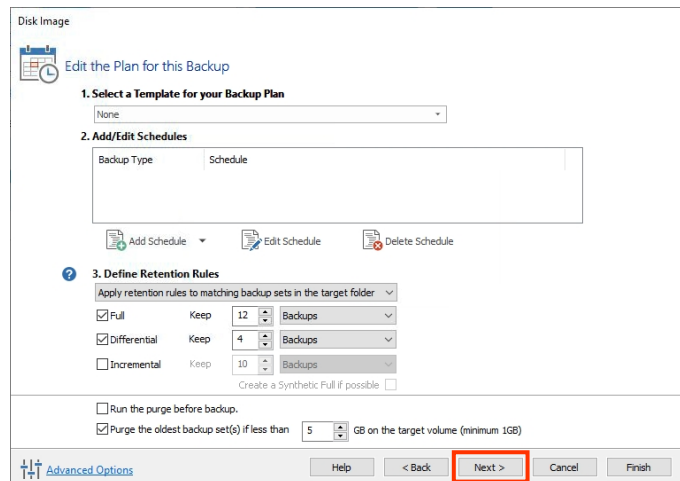

- 9) In the screen summarizing the selections, press the command **“Advanced Options”**:

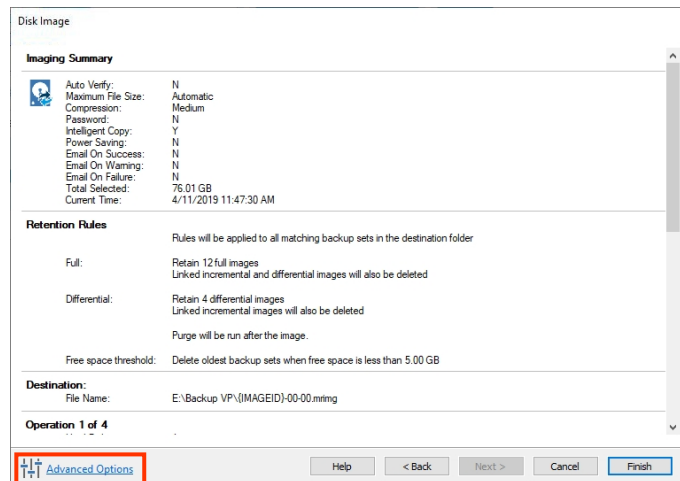

- 10) In the screen **Advanced Settings** check that:
- in the TAB **“Compression”**, the field Compression Level is set to **High**:

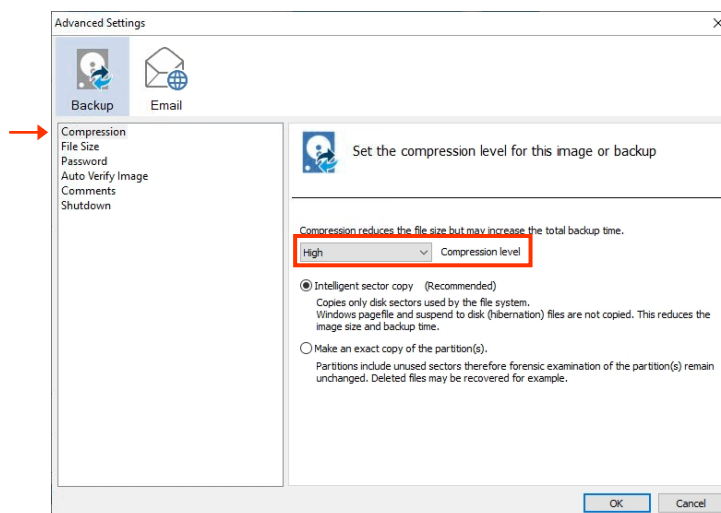

- in the TAB **File Size** the option is set to **Automatic**:

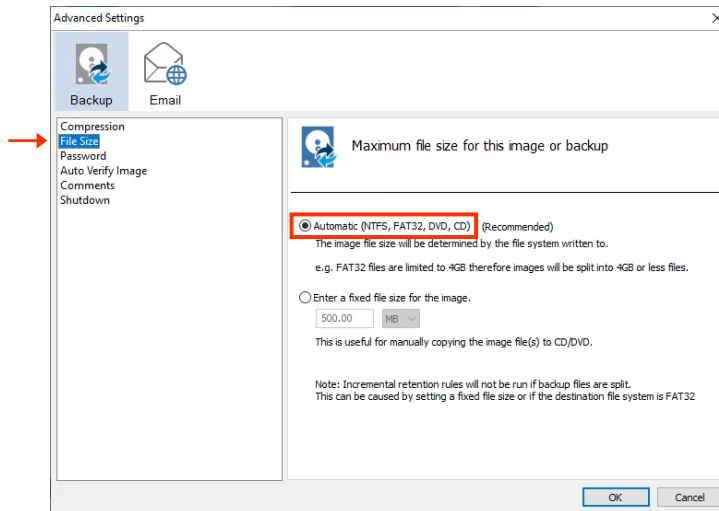

- in the TAB **Auto Verify Image** the following option is enabled: **Verify image or backup file directly after creation**. Then select the command " **OK** ":

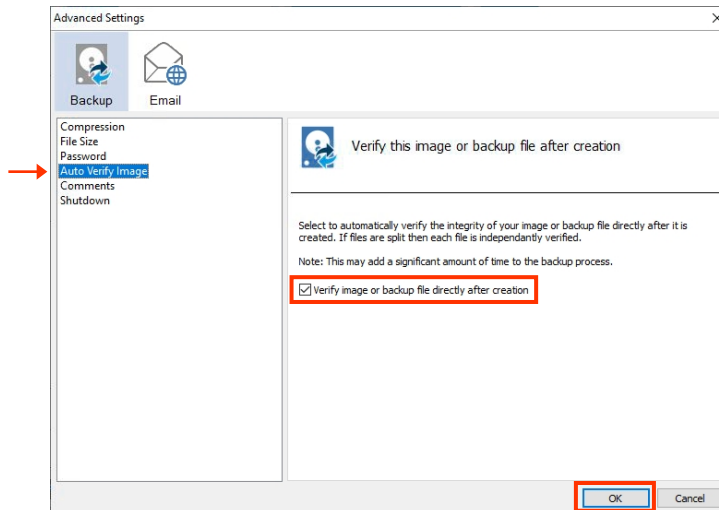

11) In the screen summarizing the selections, press the command "**Finish**":

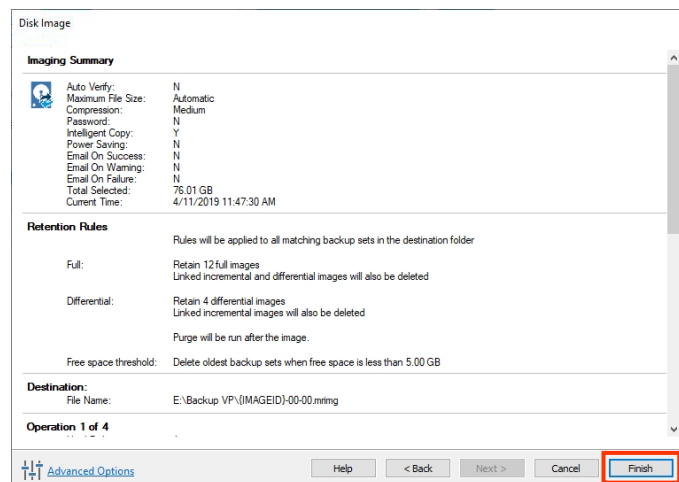

- 12) In the screen **Backup Save Options** press the command **“OK”** and then confirm by pressing **“Yes”** when being asked whether to overwrite the XML file so as to start the backup of the data:

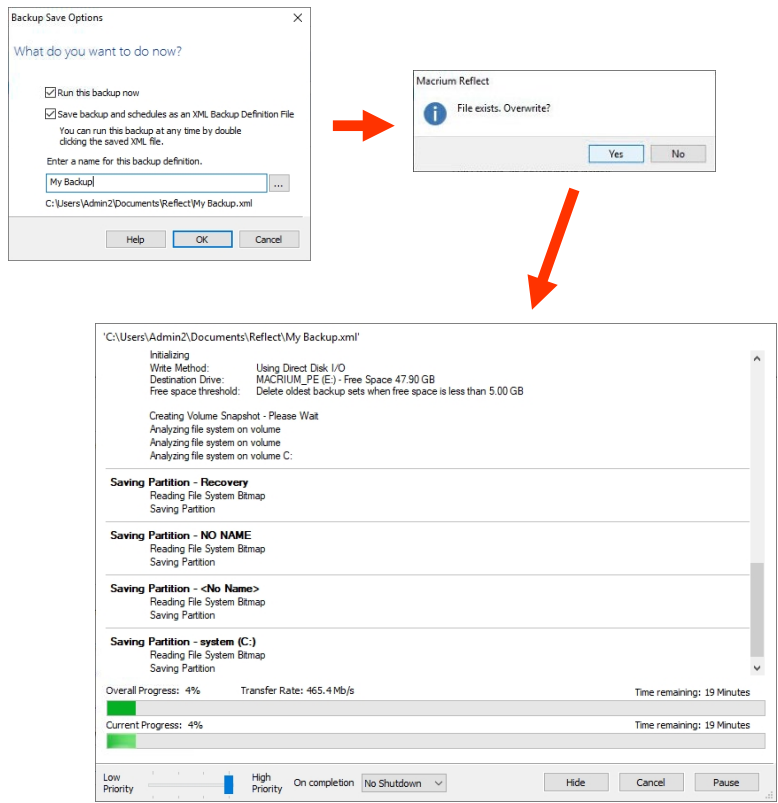

- 13) At the end of the backup, select the command **“OK”** and close the application by pressing **“Close”**:

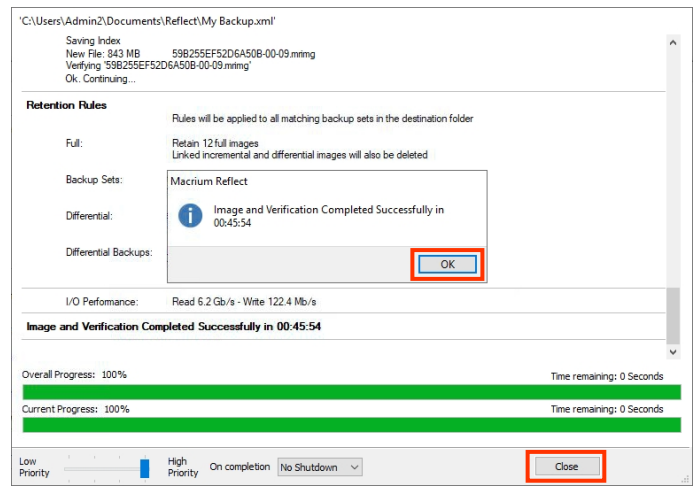

- 14) Remove the pen drive, keyboard and mouse.

6.2 CONTRAST MEDIUM INJECTOR INTERFACE

The EM equipment, provided without an injector, can be connected to a generic injector.

Preset interface signals allow for automatic synchronization between the start of the injector and the start of X-ray emission.

To connect these signals, you need to fit an adaptive cable between the connector on the EM equipment and that on the injector.

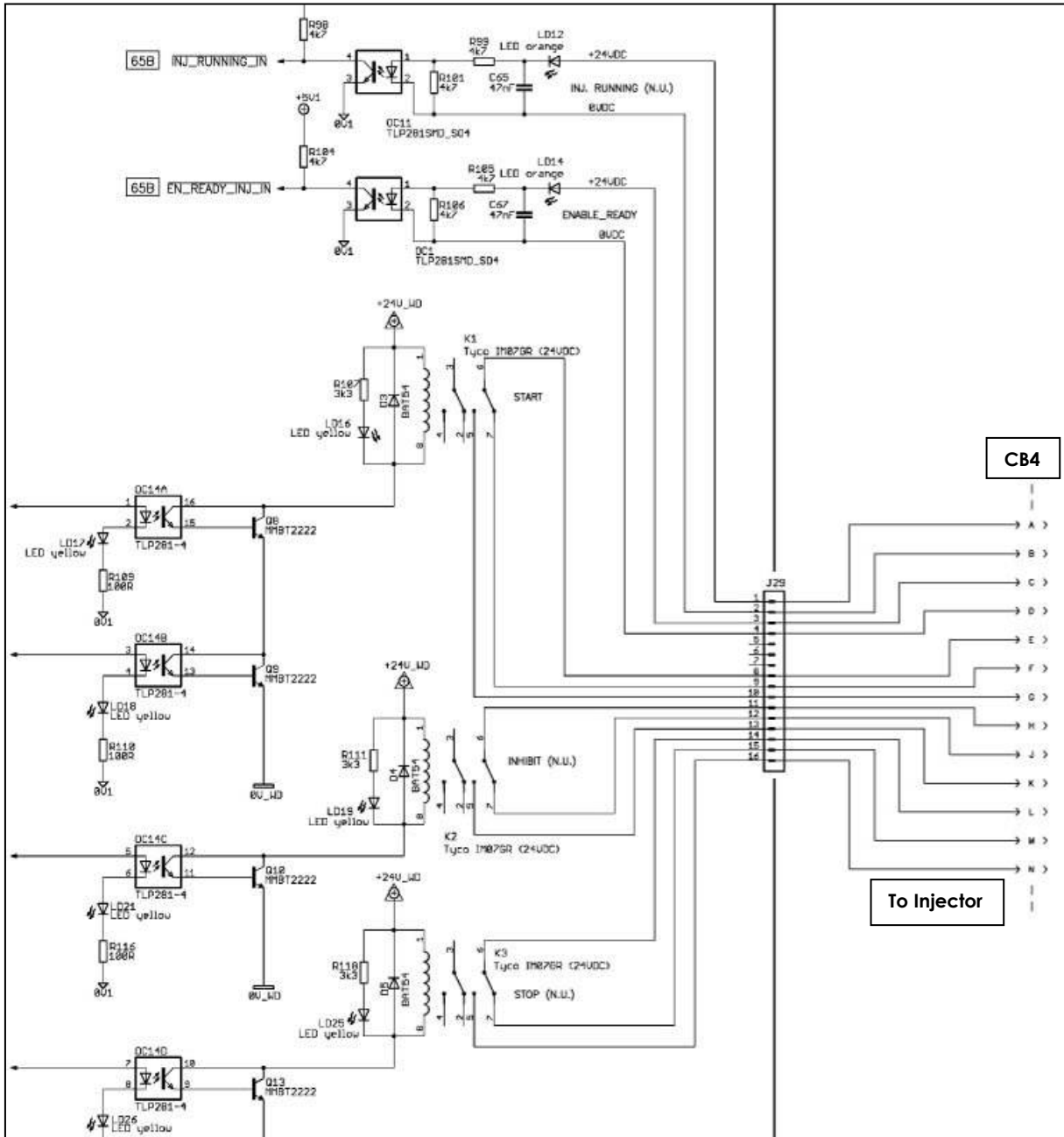

SIGNAL	DESCRIPTION	CONNECTOR
ENABLE READY	Ready signal (active high +24V DC) coming from the injector.	CB5/J29 Pins C, D
START	Command used to start the injector. Depending on the timing programmed for the DSA + injector exam, this signal is activated when you request X-ray emission.	CB5/J29 Pins E, F, G
STOP	Signal normally active: injector cannot start. This signal is deactivated (to allow the injector to start) by the START signal, to which it is linked.	CB5/J29 Pins L, M, N

The interface signal timings for x-ray emission are as follows:

In "A" condition, the injector starts before X-ray emission (T1=anticipated).
In "B" condition, the injector starts after X-ray emission (T2=delayed).

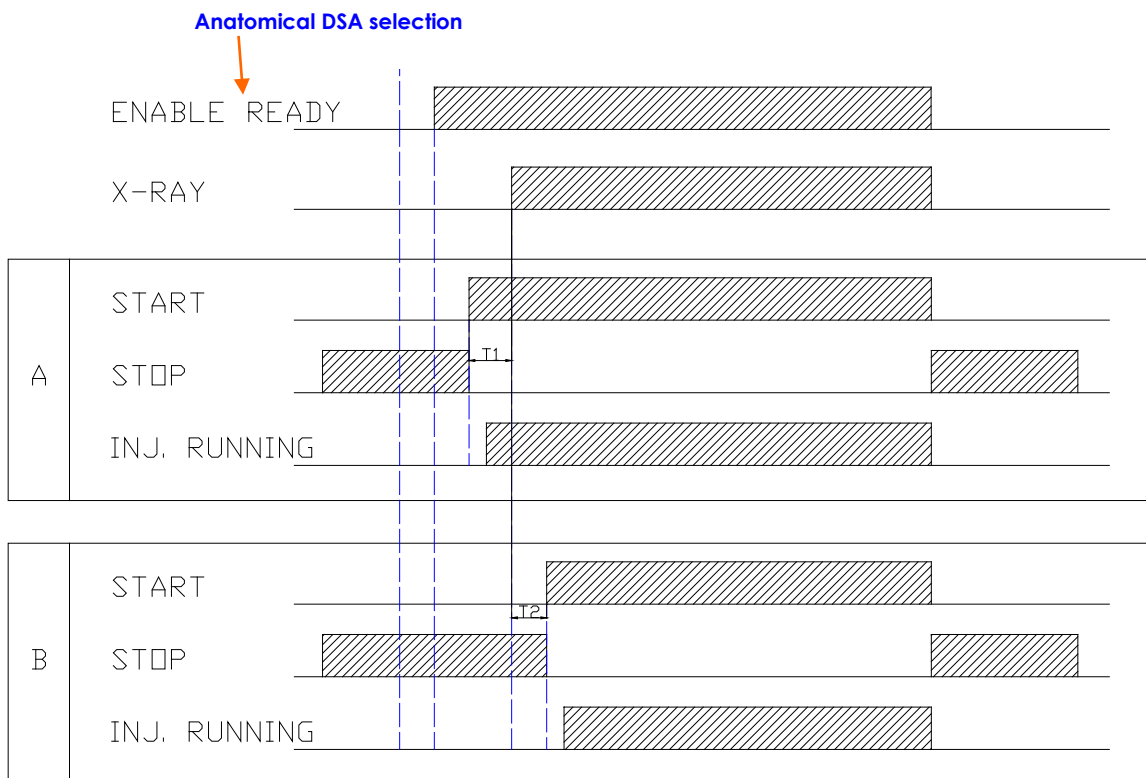

6.2.1 CREATING THE INJECTOR INTERFACE

There is a circular 19-pin female connector at the front of the stand to be used for physical connection to the injector (CM107). The equipment can also be supplied with a corresponding male connector.

The installer needs to prepare an adaptor cable for the injector, using all the foreseen interface signals: full use of the signals is required to ensure safe interface.

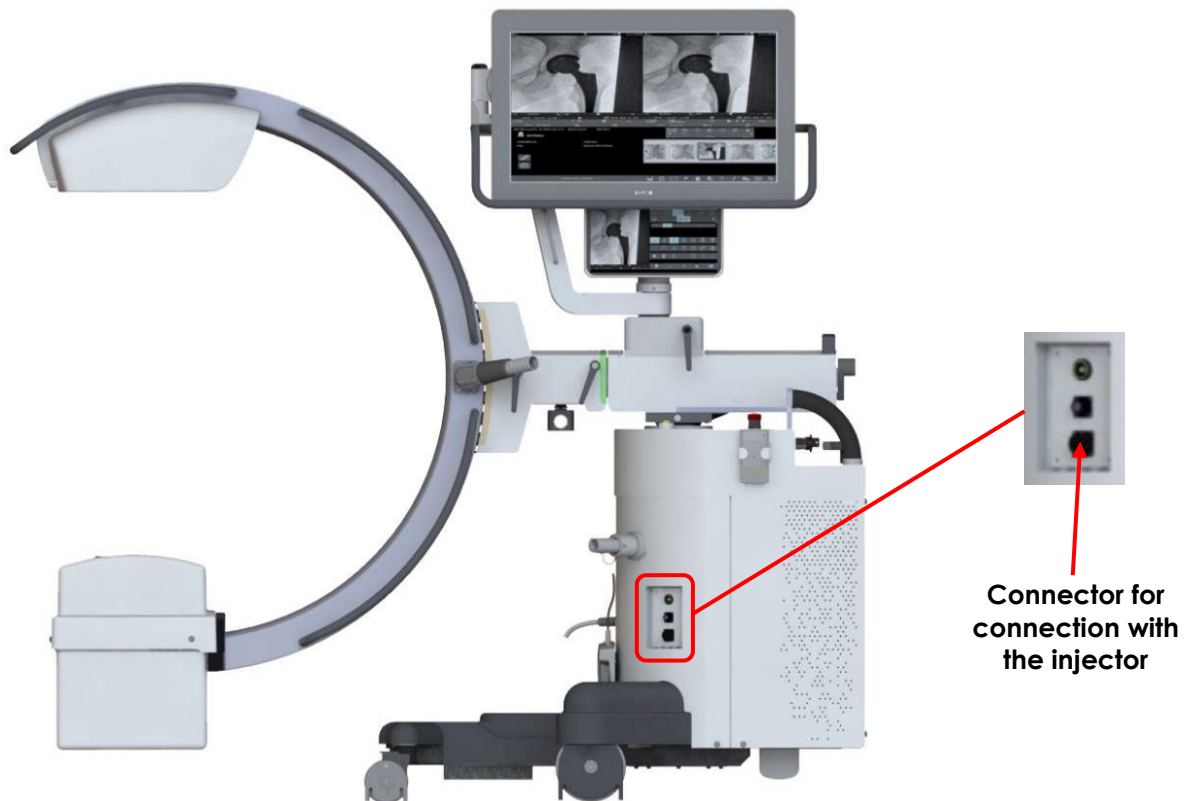

6.2.2 INJECTOR SETUP

There are two settings needed to configure the equipment for an injector:

A. *Presence of an injector:*

- **Enable the option "INJECTOR" in the "UNIT CONFIGURATION" SETUP**, as described in *Paragraph 4.3, Part 2 of this Manual*.

B. *Use of an injector for an individual DSA exam.*

- **Enable the option "ENABLE INJECTOR" in "DSA Parameters" SETUP**, regarding the anatomical DSA exam required, as described in *Paragraph 4.4.1.1, Part 2 of this Manual*.
- **Set the anticipation/delay of the injector start regard to X-ray emission, in "INJECTOR DELAY" parameter.**
When a positive time is set, the injector starts after X-ray emission beginning;
set a negative value if you want the injector to start before X-ray emission beginning.

6.3 EXPORTING/IMPORTING IMAGES

Images are stored in the "RAW" format on the ALPHA PU. To export these, you need to use a special tool, as explained below:

- 1) Connect a USB keyboard and USB mouse to the front of the monitor unit.
- 2) Switch the equipment on and then log onto the equipment as user Admin2 (see Paragraph 5.3, Part 2 of this Manual).
- 3) Use the icon on the desktop shown below to open the tool:



- 4) The follow page appears, letting you export/import studies and export/import exam configurations.

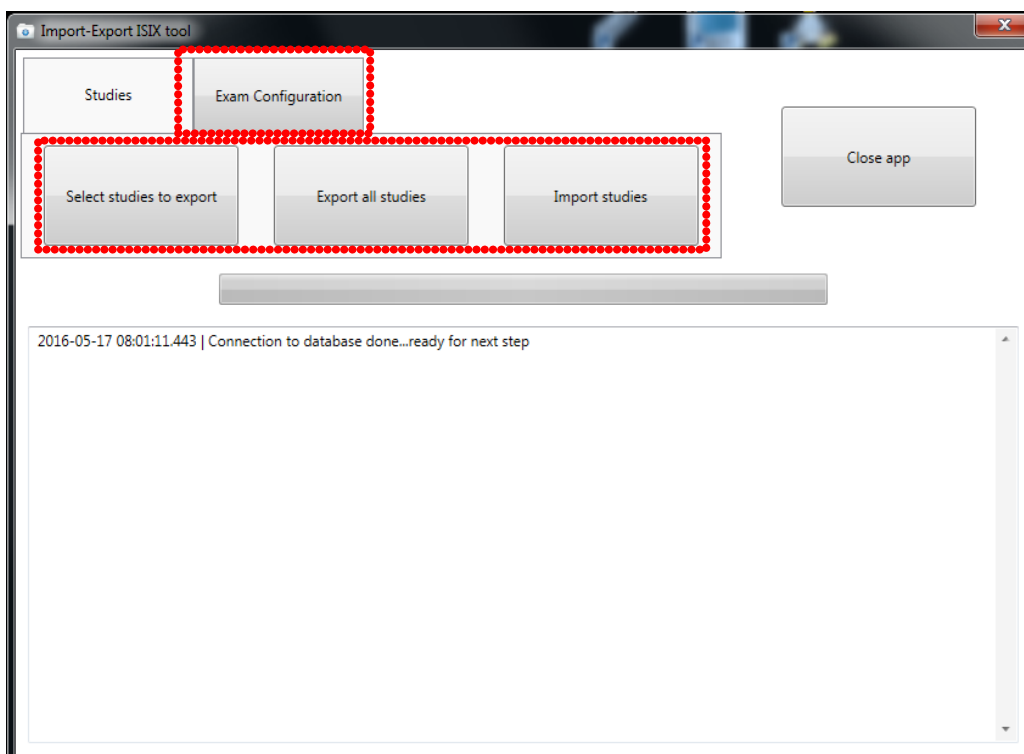

5) Select the “**STUDIES**” tab. This has three options:

- “**Select studies to export**”;
- “**Export all studies**”;
- “**Import studies**”.

6) To export a study/studies, select “**Select studies to export**” or “**Export all studies**”

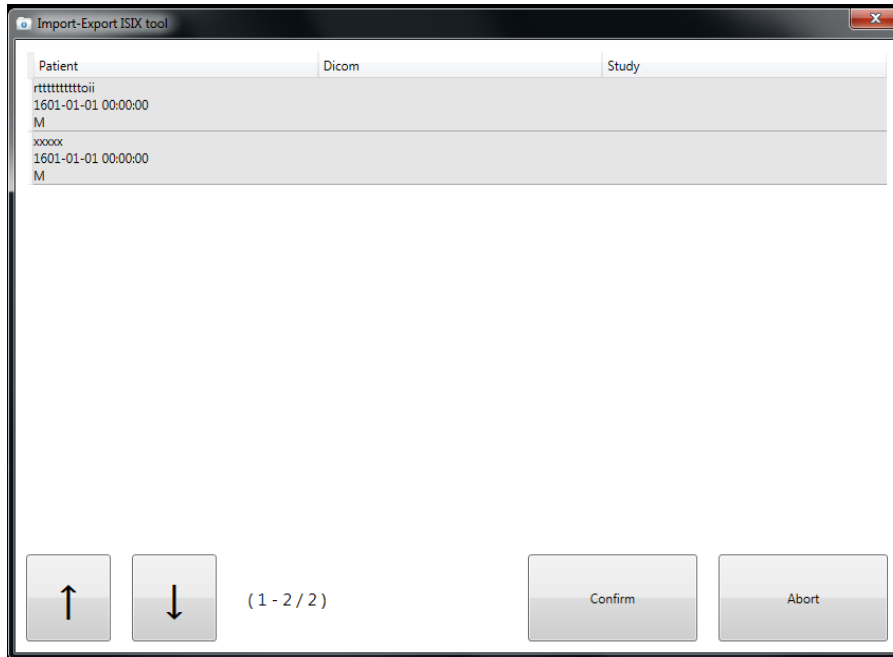

7) After selecting “**Select studies to export**”, you need to select the studies you want to export (a single study has been selected in the example below). Then click on “**Confirm**”.

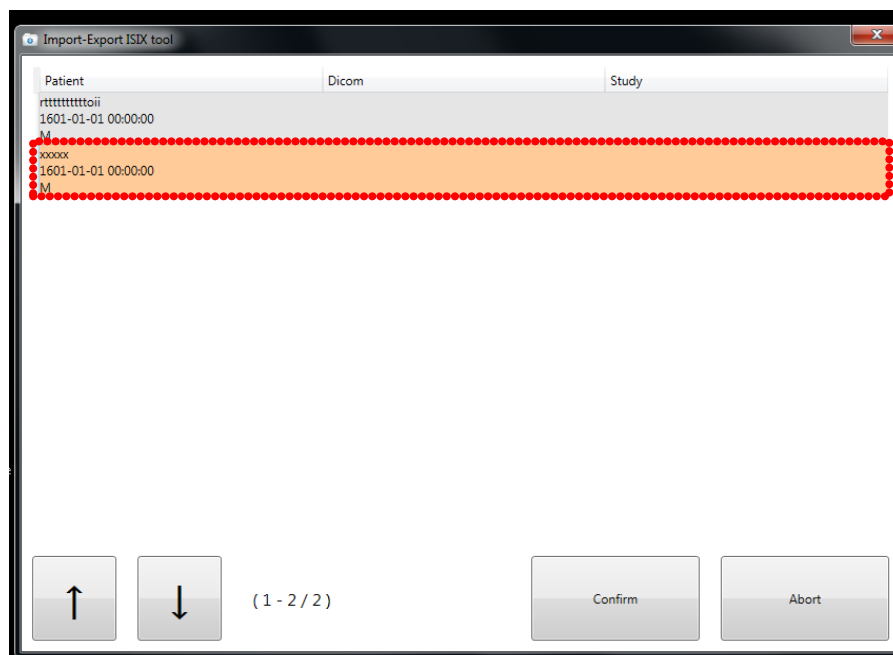

- 8) A window now opens letting you select the destination directory for the exported study/studies.

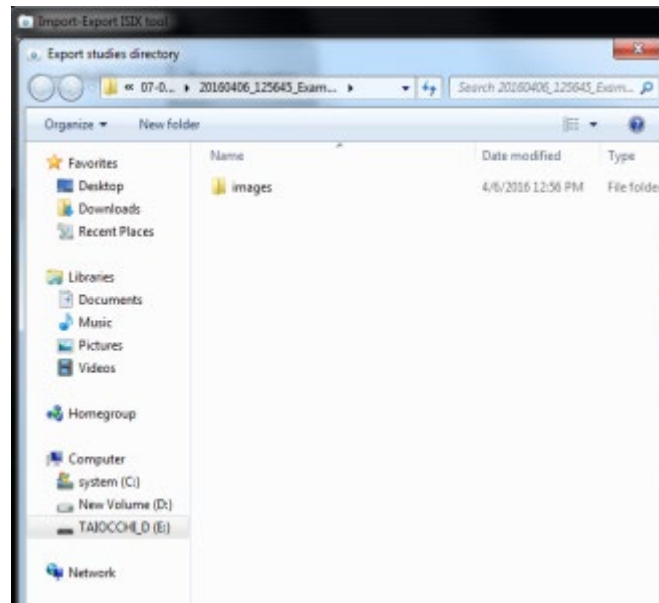

- 9) If, on the other hand, you want to import a study/studies, select "**Import studies**". Like before, a window opens letting you select the directory containing the study/studies you want to import.

6.4 EXPORTING/IMPORTING EXAMS

Exam settings are stored on the Hard Disk of the video processor computer (partition "D"). To export these, you need to use a special tool, as explained below:

- 1) Connect a USB keyboard and USB mouse to the front of the monitor unit.
- 2) Switch the equipment on and then log onto the equipment as user Admin2 (see Paragraph 5.3, Part 2 of this Manual).
- 3) Use the icon on the desktop shown below to open the tool:

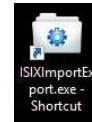

- 4) Select "**Exam Configuration**".

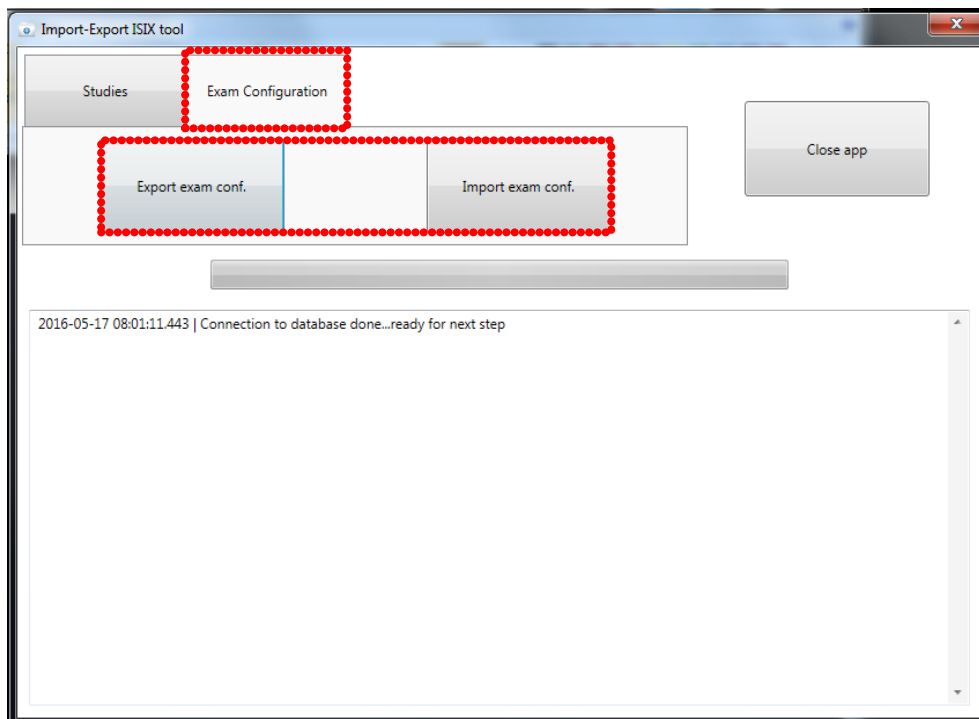

- 5) Select "**Export exam conf.**" to export the settings.
- 6) Select "**Import exam conf.**" to import the settings.
- 7) In both cases, a window opens letting you select the directory you want to export the settings to (the destination directory) or the directory containing the settings to be imported (the original directory).

6.5 REPLACING THE BACKUP BATTERY ON THE MOTHER BOARD

The manufacturer recommends to change the buffer battery of the video processor every three years. When this time has elapsed, the operator will be notified at the login, through this message:

WARNING: POSSIBLE LOSS OF NORMAL FUNCTIONALITY.
The C/MOS battery of the video processor motherboard is discharged, please contact technical assistance for its replacement.

To replace the battery, follow the instructions below.



Switch off the EM equipment and unplug the power cable from the mains.

- Remove the cover of the stand (see Paragraphs 5.1.3 in Part 5 of the Technical Manual).
- Remove all cables of the video processor group:

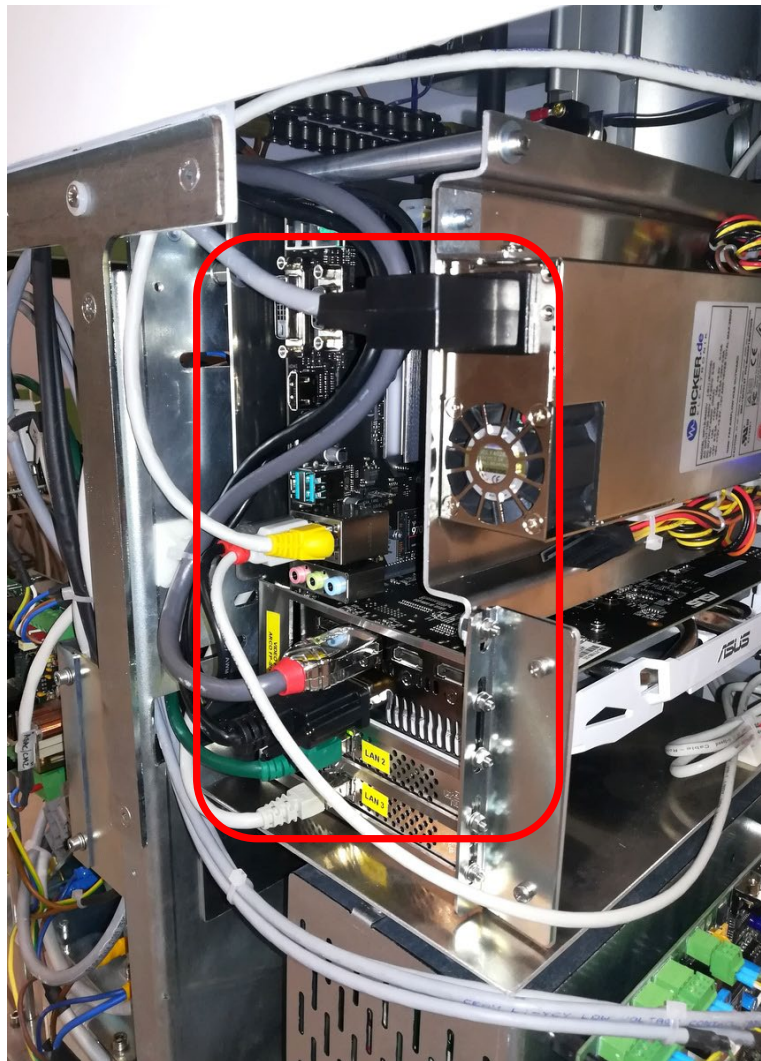

- Remove the 3 fixing screws (A) of the video processor group so as to extract it from the stand:

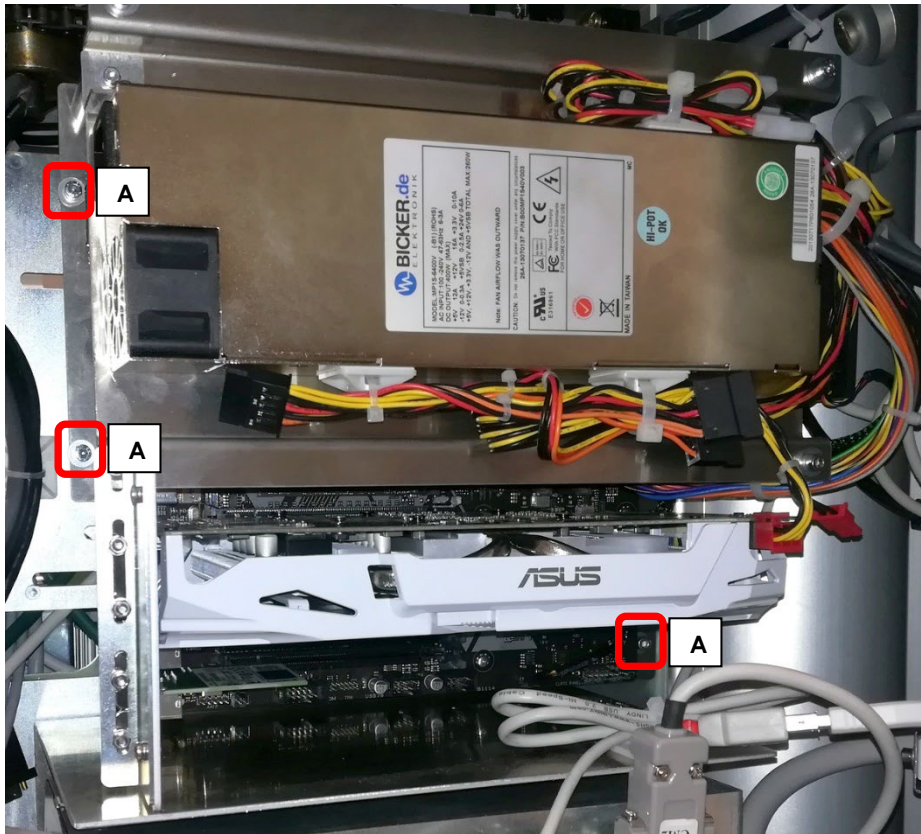

- Disconnect the power supply cable and the fixing screws (B) of the ASUS graphic board:

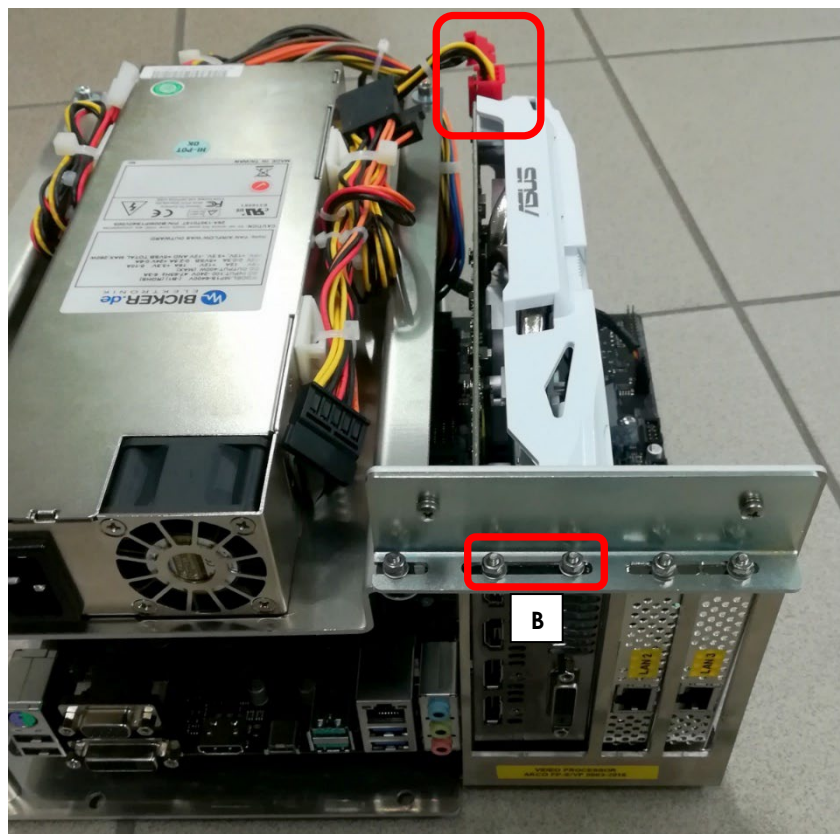

- Loosen the clip of the graphics board on the BUS PCI by pressing it towards the motherboard and remove the graphics board from the video processor group:

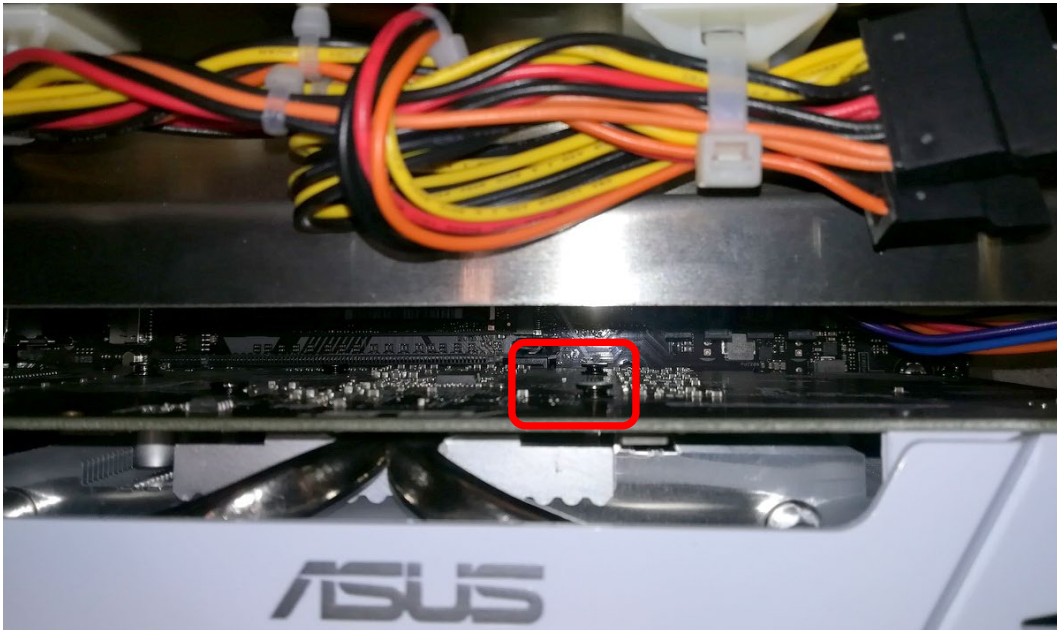

- Now, the mother board is visible and fully accessible.
- **Remove the battery, indicated in the figure below, using a suitable tool.**



Now, install the new battery: ALWAYS USE a 3V lithium battery, type CR2032.



Follow the above steps in reverse order to remount the SSD support, the video processor lateral cover and the video processor support.

- Connect a keyboard to the USB socket on the Monitor Unit.
- Connect the backup USB key which has been supplied with the EM equipment (see paragraph 2.3, Part 5 of the Technical Manual).
- Connect the power supply cable of the EM equipment to the mains socket and power up the stand.
- Turn on the video processor by short-circuiting the pins PWR and Ground (**PWR_SW**) of the motherboard:

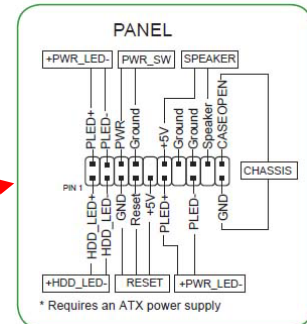
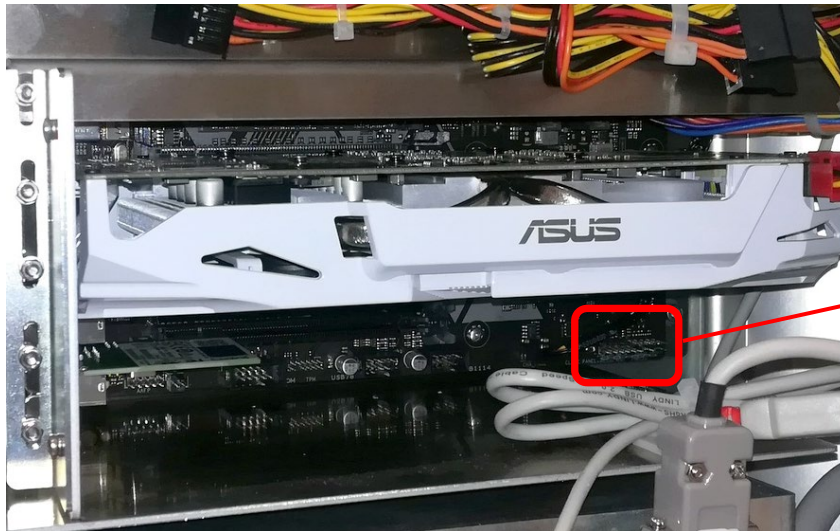

As soon as the unit turns on, press the “DEL” key on the keyboard to enter the UEFI BIOS Utility. Follow the below indicated recovery procedure in order to restore the BIOS configuration.

- The main page of the **UEFI BIOS Utility** menu will open (Advanced Mode):

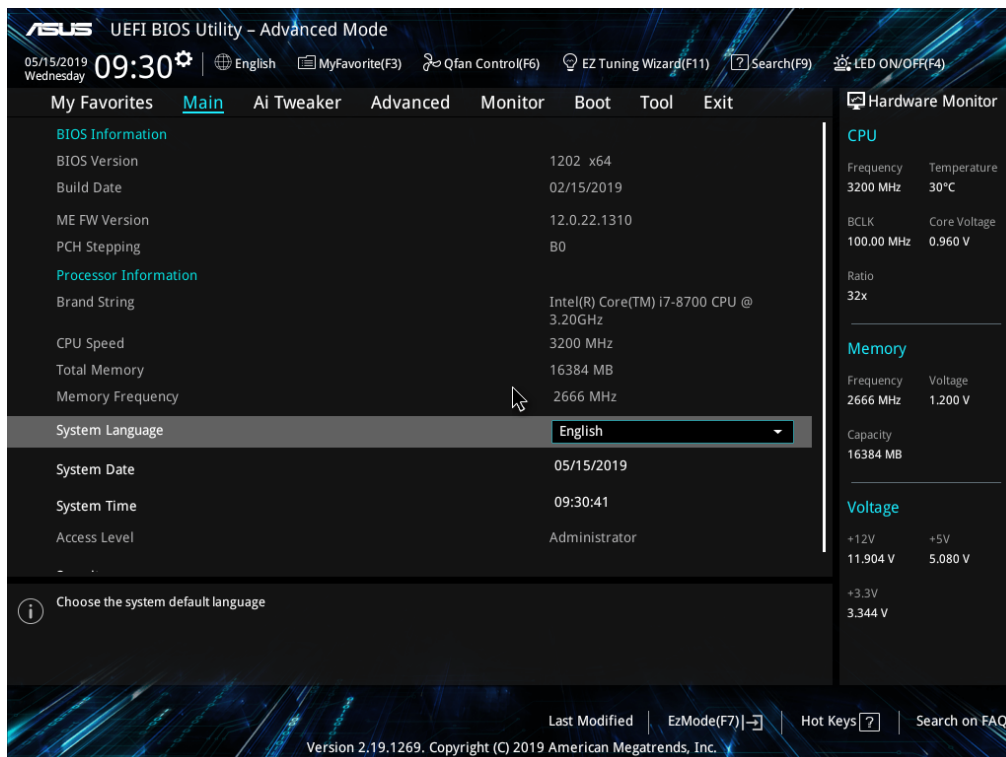

- Enter into the **Tool** menu and select **Load/Save Profile from/to USB Drive**:

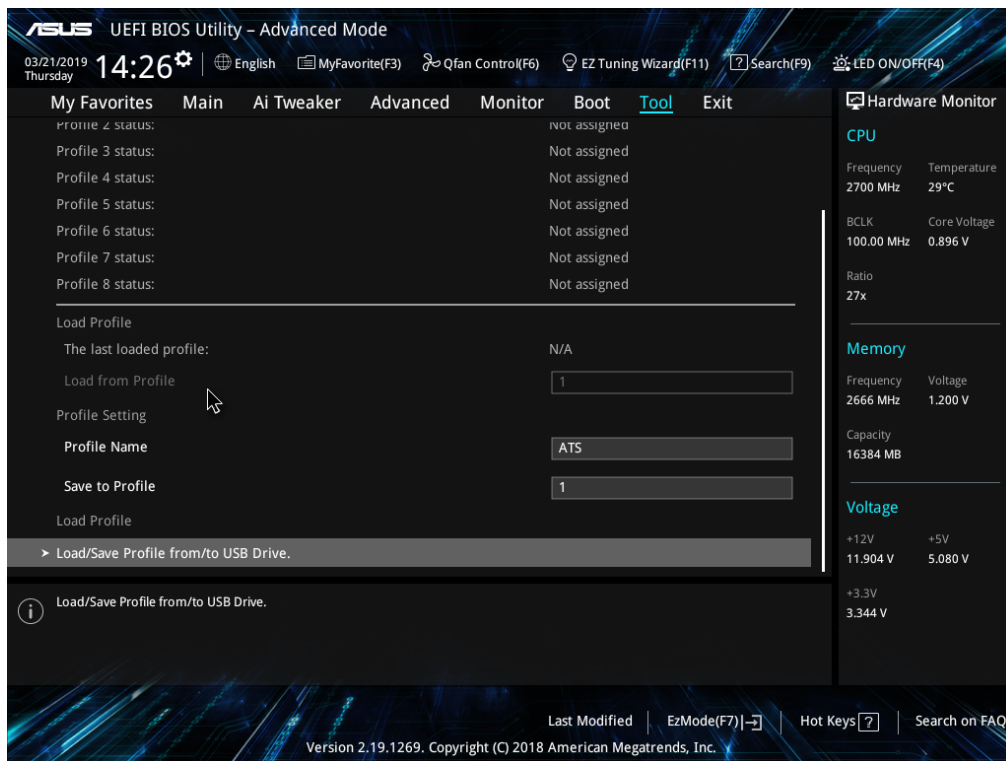

- Load the BIOS configuration file which is stored on the backup USB key supplied with the equipment in the folder BACKUP BIOS:

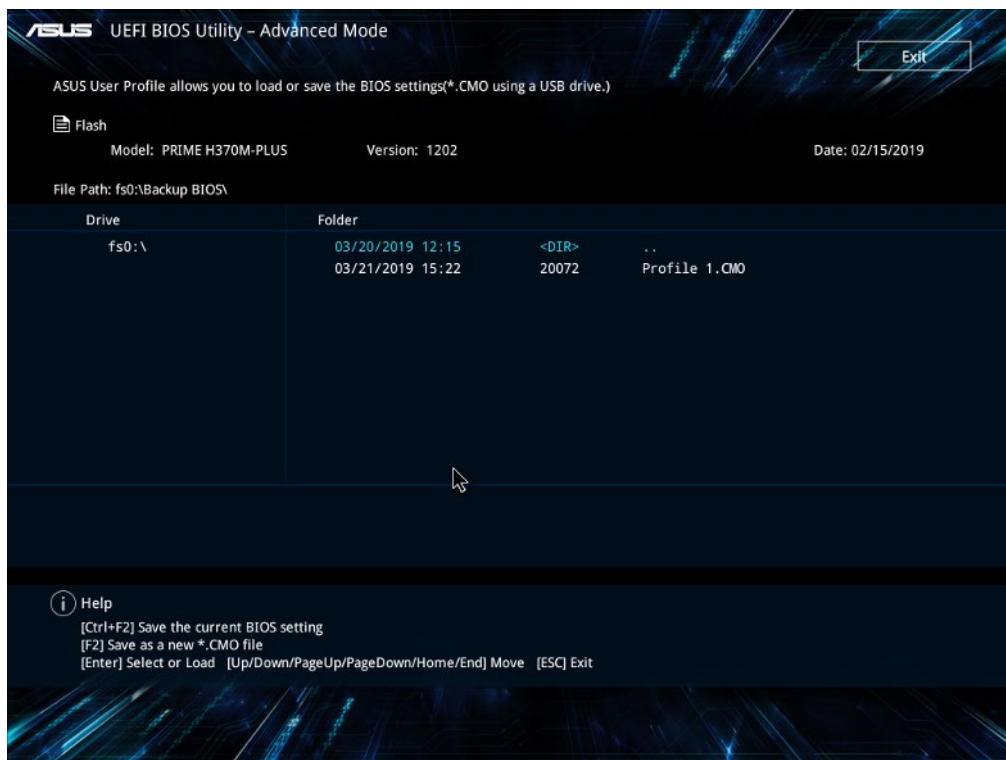

- Choose **Yes** in order to load the BIOS settings:

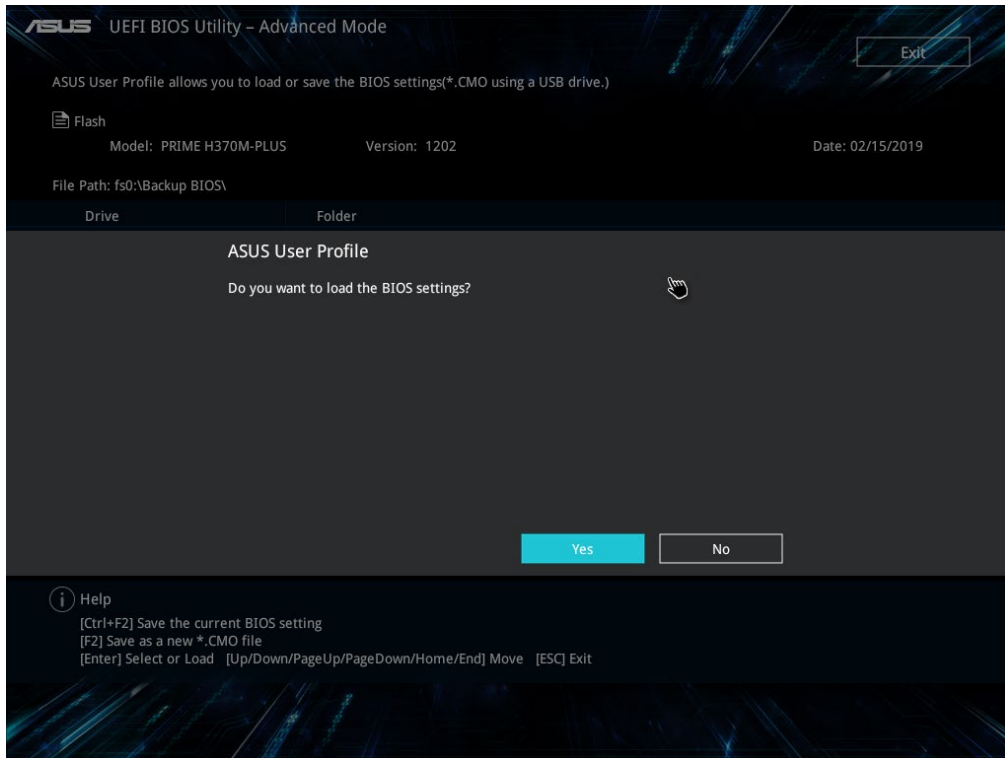

- Then check that the following menus show the correct settings.
- Enter the **Advanced** menu, select **PCH-FW Configuration** and check that the option **PTT** is set in the **TMP Device Selection** field.

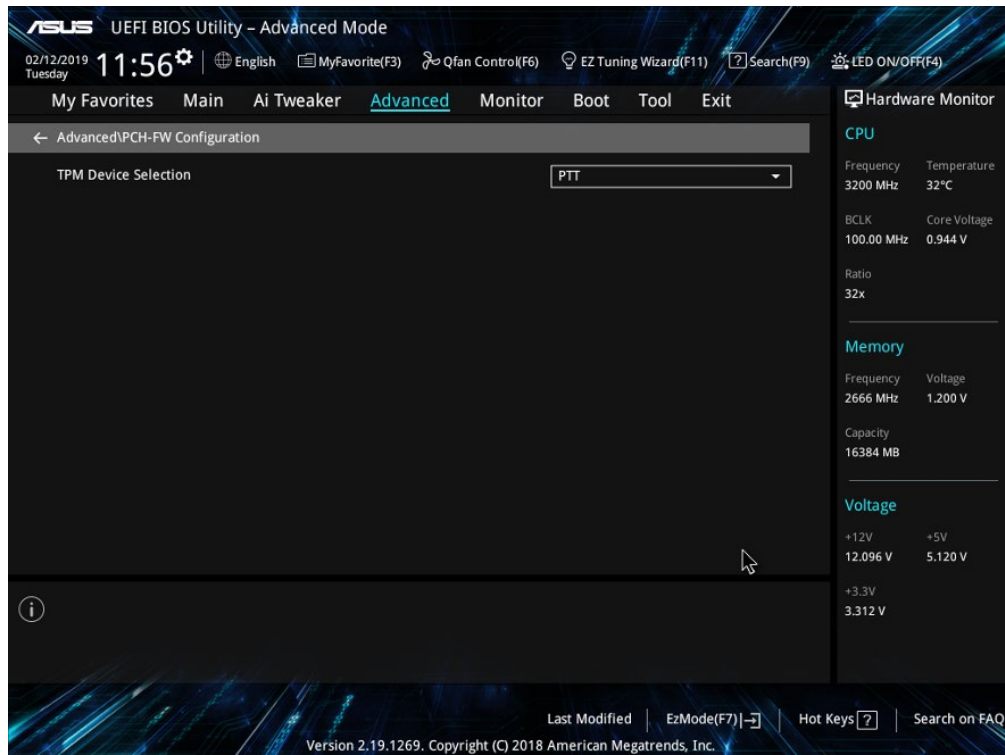

- Enter the **Advanced** menu, select **APM Configuration** and check that the option **Power On** is set in the **Restore AC Power Loss** field.

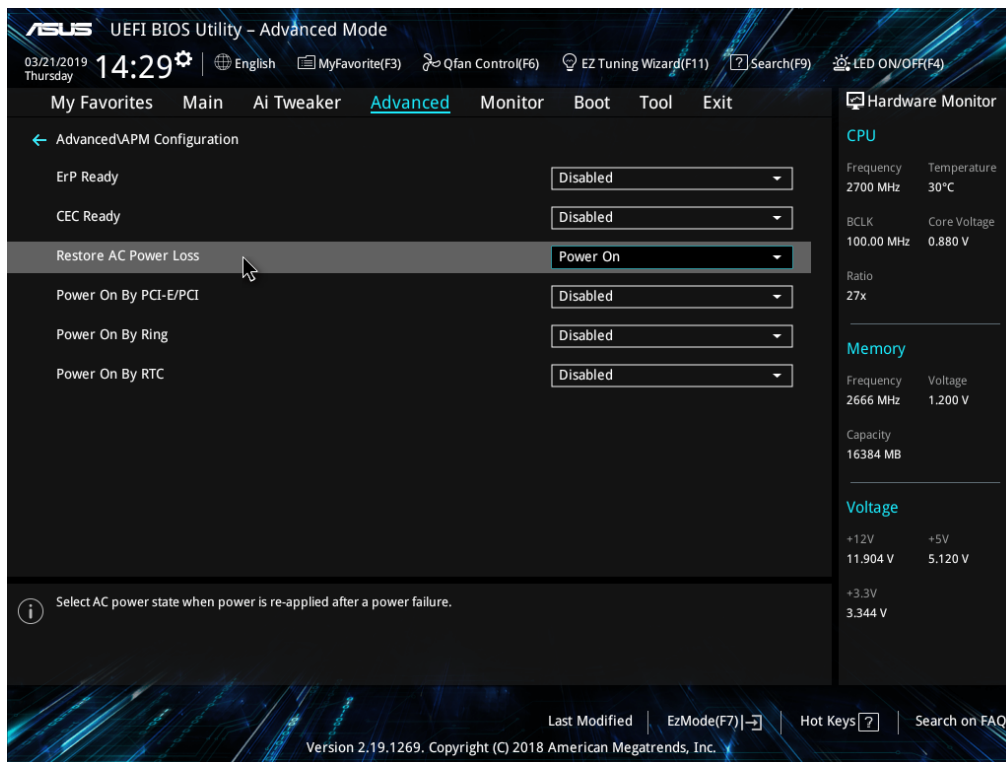

- Return to the **Advanced** menu, select **NVMe Configuration** and check that both of the two **Samsung SSD 970 PRO 512GB** Hard Disks are present.

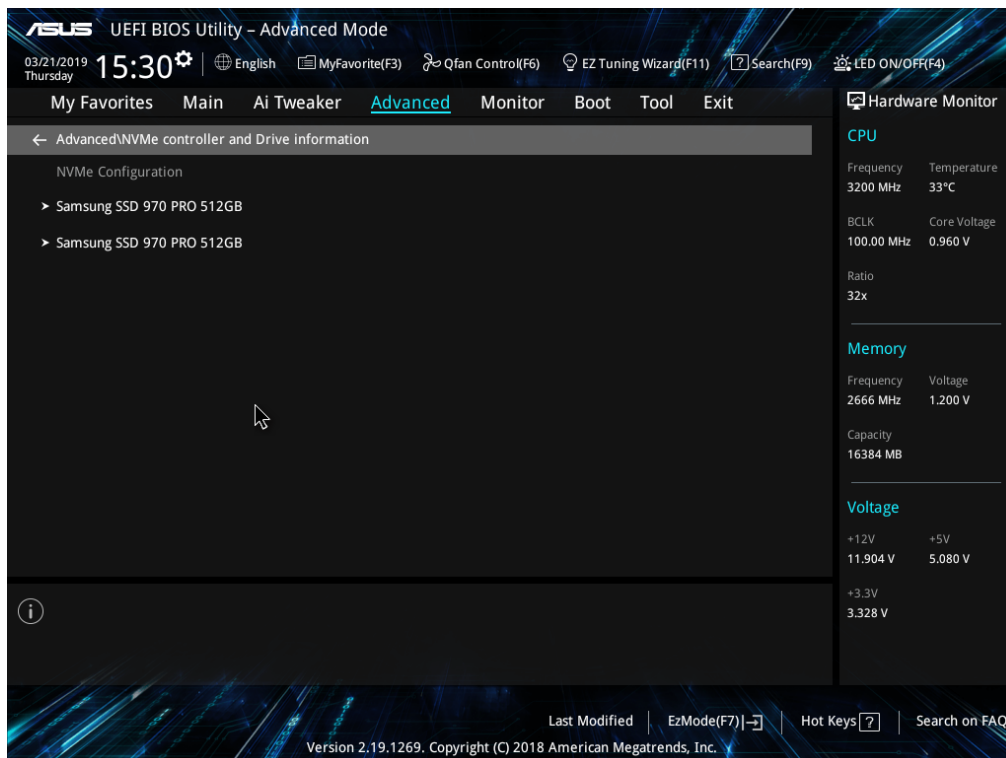

- Enter the **Boot** menu and check that the option **Disabled** is set in the **Fast Boot** field.

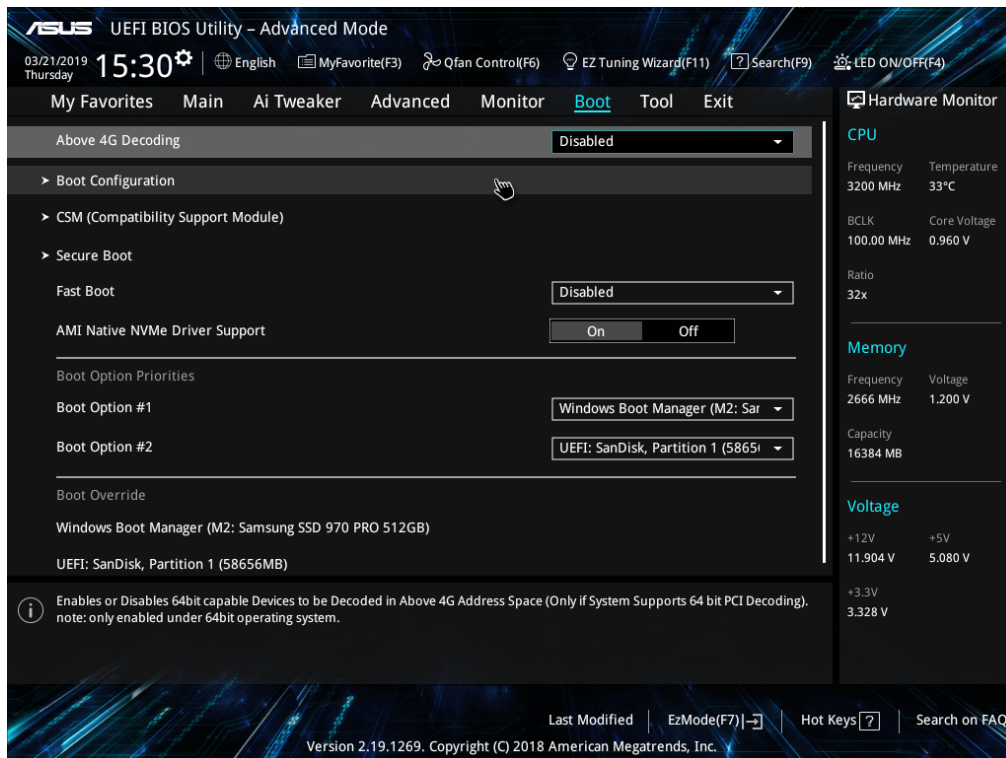

- Still in the **Boot** menu, select **Boot Configuration** and check that the displayed settings correspond to those shown in the following image:

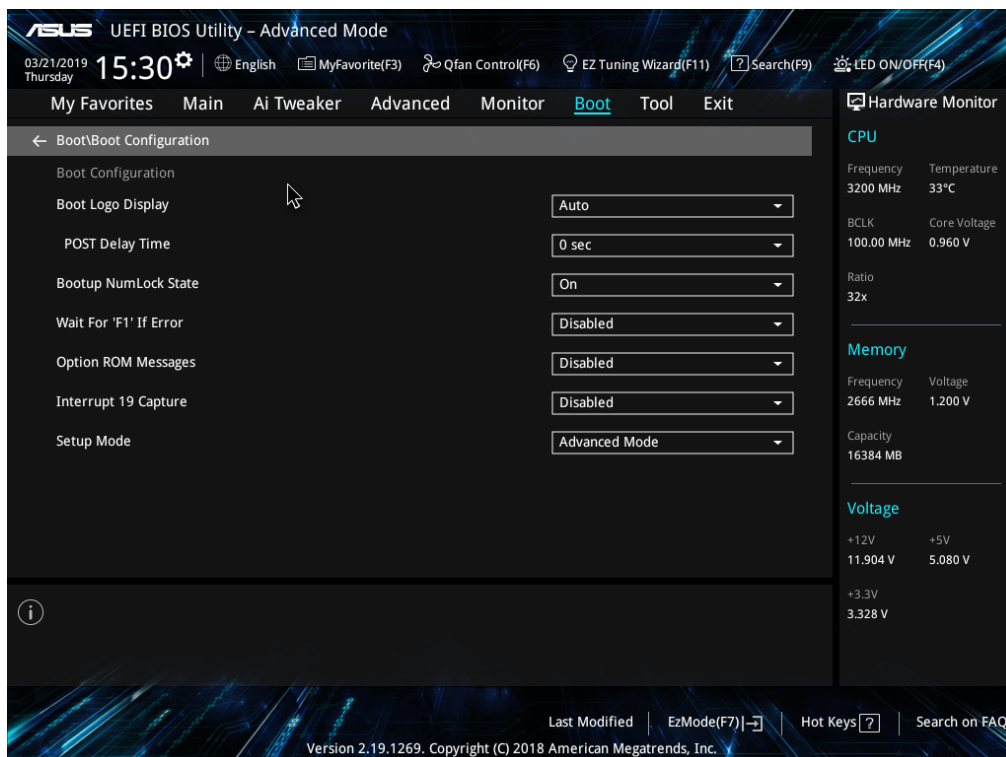

- Enter the **Ai Tweaker** menu and check that the settings correspond to those shown in the following image:

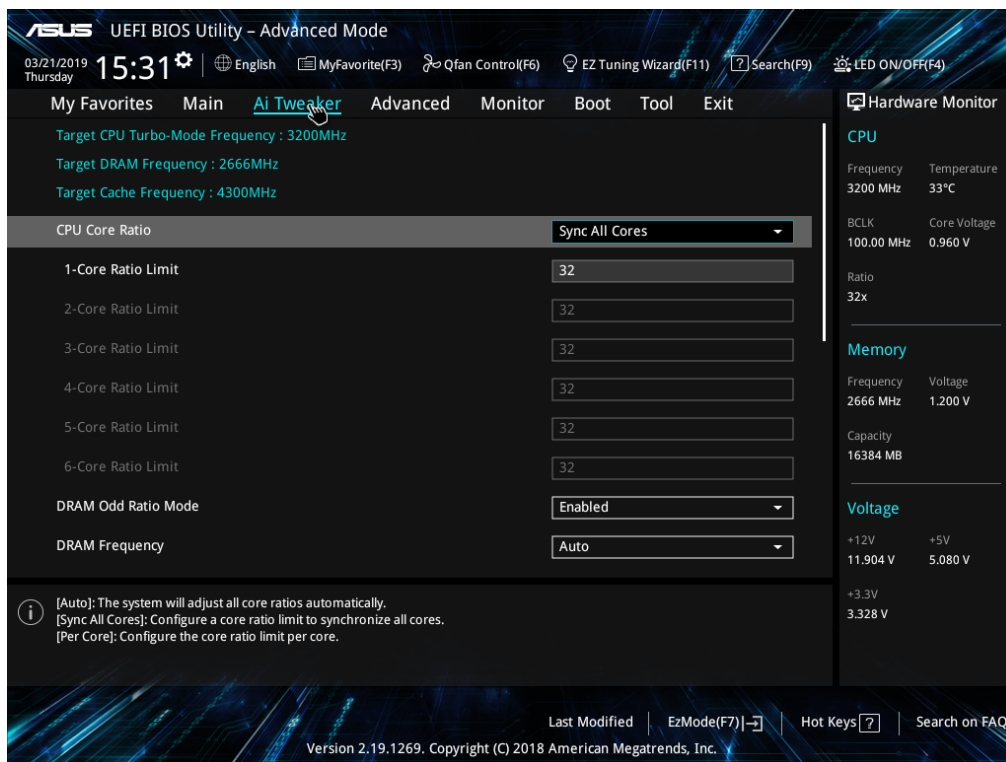

- Still in the **Ai Tweaker** menu, select **Internal CPU Power Management** and check that the settings correspond to those shown in the following image:

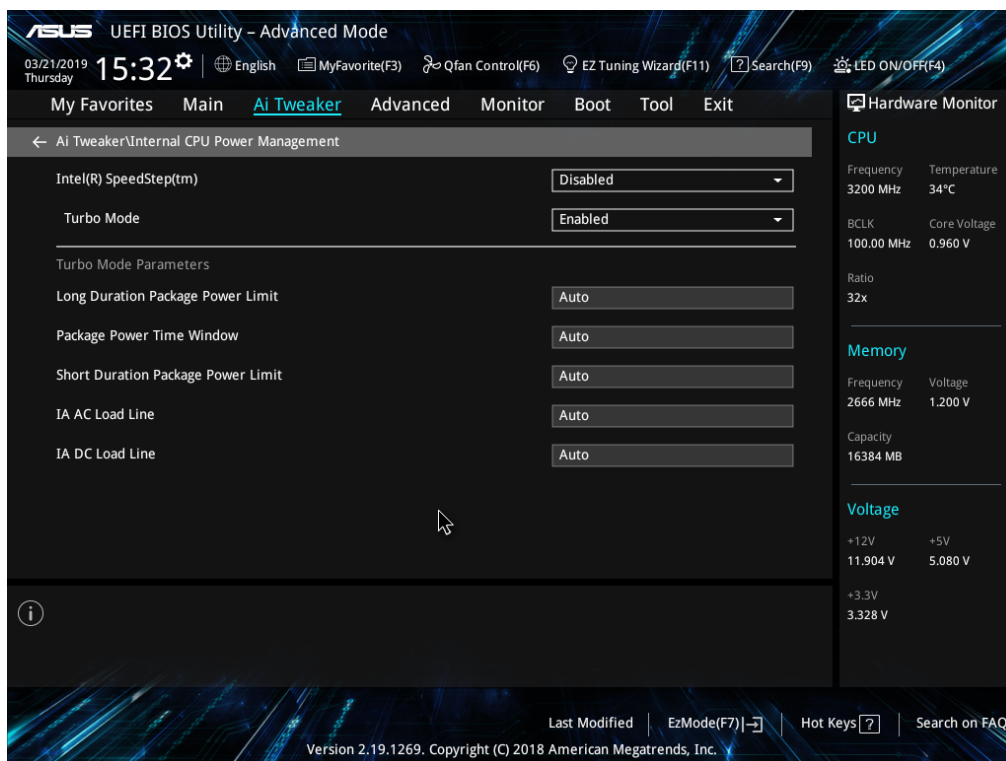

- Enter the **Monitor** menu, then select **Q-Fan Configuration** and check that the settings correspond to those shown in the following image:

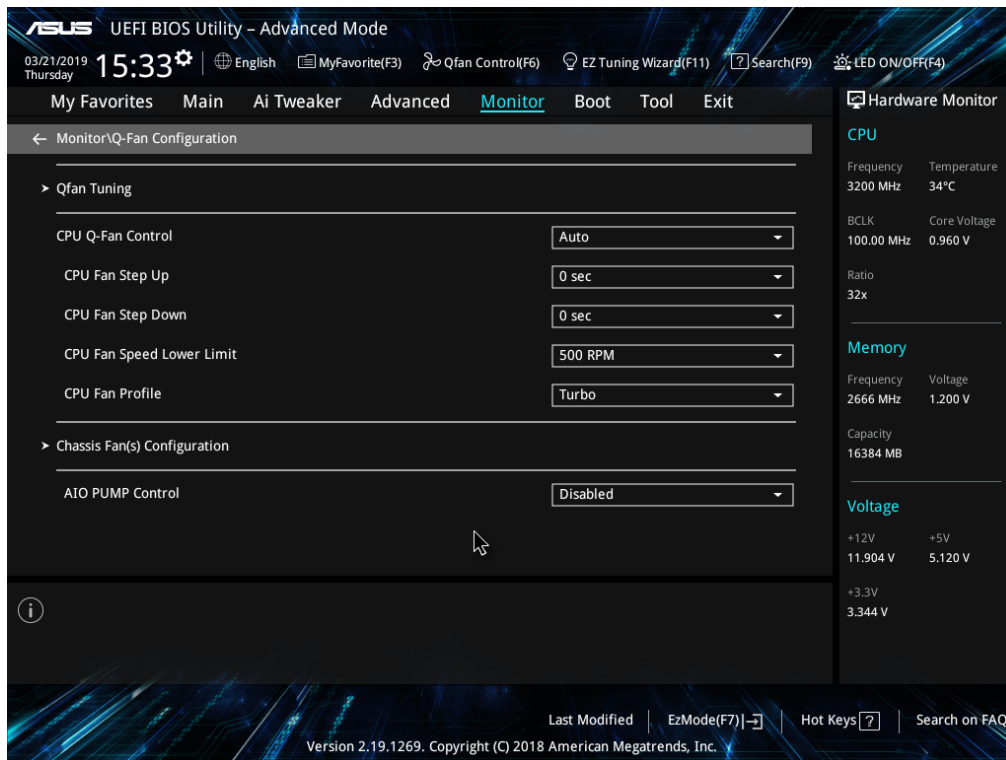

- Still in the **Monitor** menu, select **Chassis Fan(s) Configuration** and check that the displayed settings correspond to those shown in the following image:

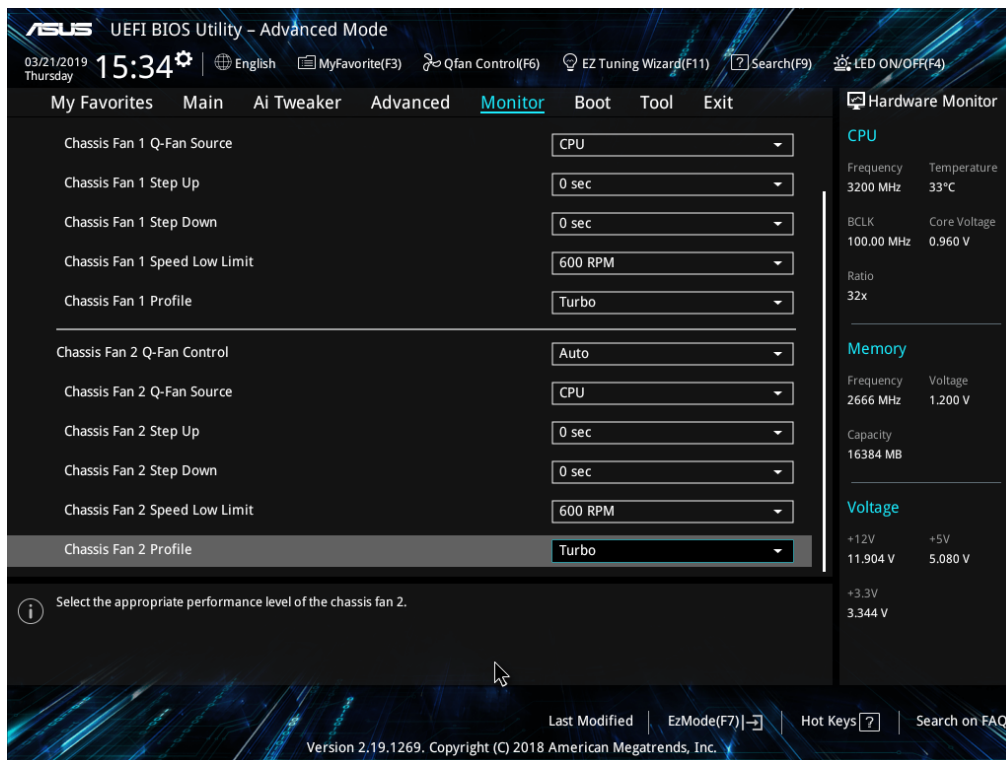

- Enter the **Exit** menu and select **Save Changes & Reset**.

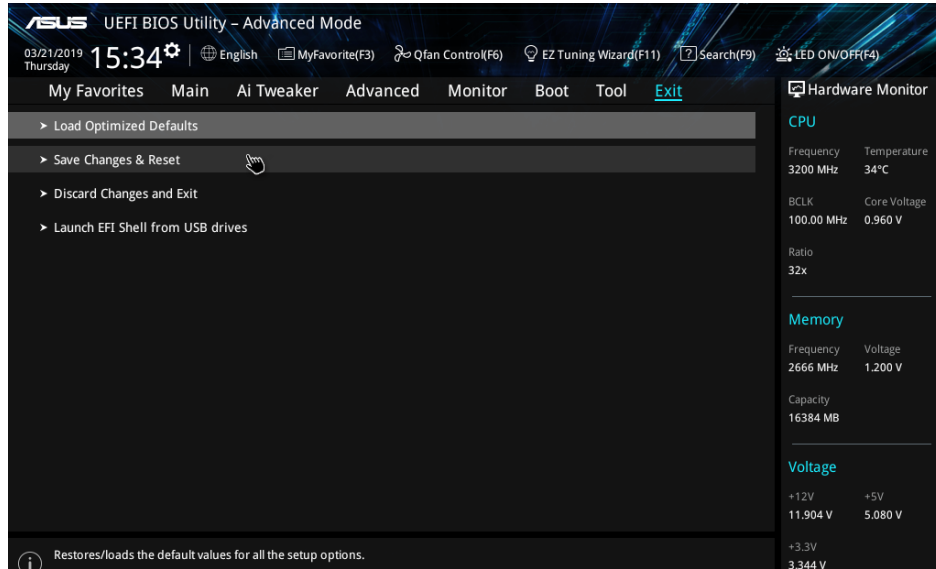

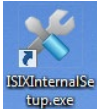
- The video processor will then reboot automatically. Disconnect the keyboard and reinstall the cover of the stand.
- Login as **Windows Administrator** (see Paragraph 5.2, Part 2) and run the **ISIX Internal Setup** application. 
- Enter the login password: **breatheme** and in the field **Battery Estimated Life [months]** enter the battery life (recommended setting = **36**). Then press **Set**.

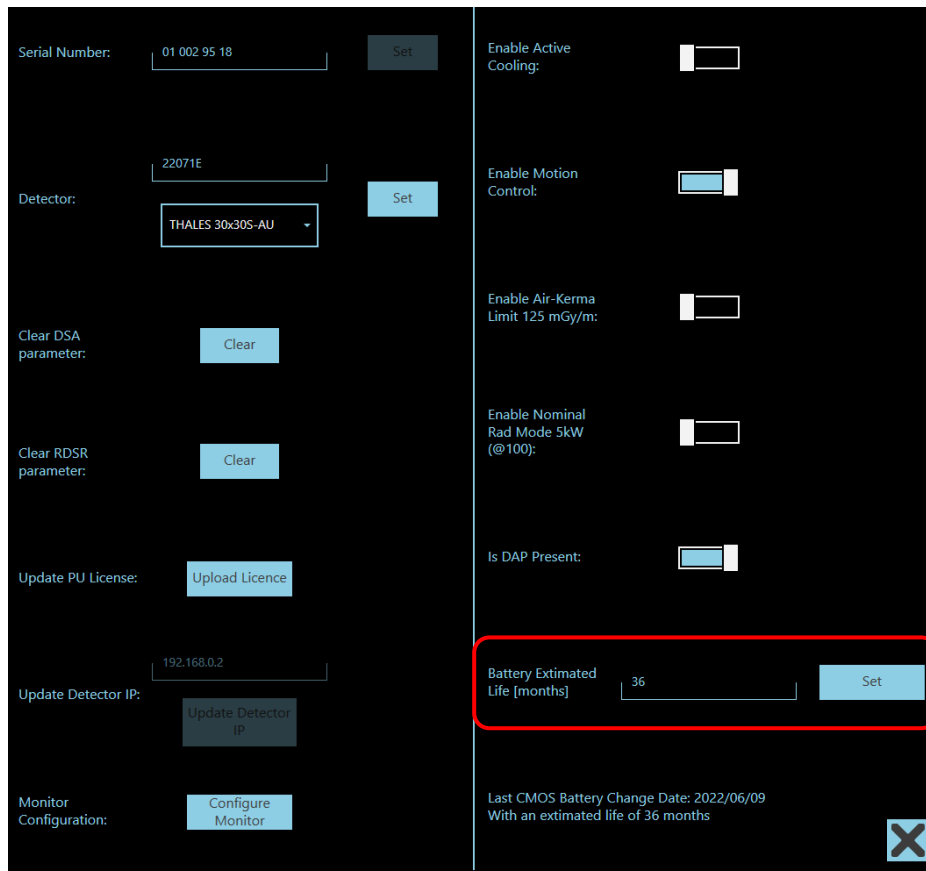

- The *Last CMOS Battery Change Date* will be updated automatically.

TEST SHEET:

The Acceptance Test covers all the checks and tests listed in the Test Sheet below.

The Test Sheet should be filled in by the user:

- immediately after installing the equipment,
- during routine maintenance,
- after all extraordinary maintenance.

Code	Operation	Notes	Results
A.1	Power supply cable of the equipment		
A.2	Stand cable sheath (C-arm connection).		
A.3	Stand cable sheath (connection with the monitor support arm).		
A.4	X-ray footswitch cable and connector.		
A.5	X-ray handswitch cable and connector.		
A.6	Control Panel connection cable sheath.		
B.1	C-arm angling movement.		
B.2	C-arm angling brake.		
B.3	C-arm rotation.		
B.4	C-arm rotation brake.		
B.5	Longitudinal C-arm movement		
B.6	Longitudinal C-arm movement brake.		
B.7	Wig-wag C-arm movement.		
B.8	Wig-wag C-arm movement brake.		
B.9	Vertical C-arm movement (motorized up and down movement).		
B.10	Smooth movement of stand wheels on floors.		
B.11	Parking brakes on stand wheels.		
B.12	±90° rotation of rear stand wheels.		
B.13	Fixing of the covers on the stand.		
B.14	State of the monoblock.		
B.15	State of the top cover on the monoblock.		
B.16	State of the Control Panel.		
B.17	Orientation movement of the Control Panel.		
B.18	State of the Up/Down controls on the column.		
B.19	State of the emergency stop buttons.		
B.20	State and function of the On/Off key.		
B.21	Movements of the monitor support arm.		
B.22	Up and down movements of the main monitor		
B.23	Inclination movements of the main monitor		
B.24	Orientation of the main monitor		
B.25	Holding function of the hook for the transport position of the main monitor		
B.26	Smooth movement of the anti-scatter grid carriage.		
B.27	State of the anti-scatter grid.		
B.28	C-arm angling movement.		
B.29	C-arm angling brake.		
B.30	C-arm rotation.		
B.31	C-arm rotation brake.		
C.1	General state of the stand power unit components (dirt and corrosion).		
C.2	Correct powering up of the stand (indicated by a sequence of 4 beeps).		
C.3	Login procedure from the monitor as well as from the Control Panel.		
C.4	Creating a new study		
C.5	Emergency shutdown.		
C.6	Restart after emergency shutdown.		
C.7	Vertical C-arm movement		
C.8	Emergency stop buttons for the vertical C-arm movement		

Code	Operation	Notes	Results
C.9	Vertical movement safety (see Daily Test).		
C.10	X-ray warning light and LEDs for Low Dose fluoroscopy		
C.11	Image + indicators on monitors for Low Dose fluoroscopy.		
C.12	Image and indicators on CP for Low Dose fluoroscopy.		
C.13	Correct automatic kV search.		
C.14	Collimator: square field and parallel shutters		
C.15	DAP value.		
C.16	Indication of virtual collimators on the monitors.		
C.17	Saving of the images and transfer to the memory area of the monitor.		
C.18	X-ray warning light and LEDs in High Quality fluoroscopy		
C.19	Image and indicators on monitors for High Quality fluoroscopy		
C.20	Image and indicators on CP for High Quality fluoroscopy.		
C.21	Correct automatic kV search.		
C.22	DAP value.		
C.23	X-ray warning light and LEDs for radiography.		
C.24	Image and indicators on CP for radiography.		
C.25	Image + indicators on monitors – radiography.		
C.26	230 V AC power supply: Radiography time for 40 kV, 50 mAs	Limits: 654 ÷ 885 ms	
	120V AC power supply: Radiography time for 40 kV, 25 mAs	Limits: 650 ÷ 880 ms	
C.27	230 V AC power supply: Radiography time for 80 kV, 20 mAs	Limits: 485 ÷ 655 ms	
	120V AC power supply: Radiography time for 80 kV, 10mAs	Limits: 476 ÷ 644 ms	
C.28	DAP value.		
C.29	Centring of Laser Localizer (<i>optional</i>)		
C.30	Video printer (<i>optional</i>)		
D.1	X-ray dose intensity.		
D.2	Automatic X-ray dose control.		
D.3	Grey scale.		
D.4	Spatial resolution.		
D.5	Noise level.		
D.6	Min contrast.		

Date:

Operator's signature: