

SST-3100 FMTS System (V1 & V2)

Service & Installation Manual SUMMIT P/N 09526 REV. A



Document Version: V1.2





SHINYOUNG FOR M Co., Ltd.
423-1, Jingeononam-ro, Jingeon-eup,
Namyangju-si, Gyeonggi-do, Korea 12129
TEL: +82 070 8680 3693
Fax: +82(02)3423-3059

EC	REP
----	-----

Obelis s.a.
Bd. General Wahis 53-1030 Brussels
Belgium
TEL: +32 (0) 2 732 5954
FAX: +32 (0) 2 732 6003

Document No.: SYM-SST3100_Eng

SST-3100 Distribution

No.	Model No.	Description
1	SST-3100 (V1)	<p>Motorized (auto-tracking) system</p> 
2	SST-3100 (V2)	<p>Motorized (auto-tracking) system with a mobile patient table</p> 

Revision Record

Revision No.	Date	Reason for Change
1.0	Feb 1, 2018	Original
1.1	Mar 1, 2021	Content updated
1.2	Apr 20, 2021	Additional content updated with a new form

Applied Standards

No.	Standard No.	Title of Standard
1	ANSI/AAMI ES60601-1: A1:2012 & C1:2009/(R)2012 & A2:2010/(R)2012	Medical Electrical Equipment - Part 1: General Requirements for Basic Safety and Essential Performance (IEC 60601-1:2005, MOD) (Consolidated Text) (Includes ANSI/AAMI ES60601-1:2005/(R)2012 and A1:2012, C1:2009/(R)2012 And A2:2010/(R)2012)
2	CSA CAN/CSA-C22.2 NO. 60601-1:14	Medical electrical equipment - Part 1: General requirements for basic safety and essential performance

Table of Contents

Chapter i Safety Information

- Introduction
- General Symbols
- Electric & Electronic Symbols
- Packing Symbols
- Label Symbols
- General Safety
- Electrical and Mechanical Safety
- User Maintenance / Servicing
- Hardware / Software Modifications
- Environmental Safety and Operating Environment
- Manufacturer's Responsibility

Chapter 1 Introduction

- 1.1 Introduction
- 1.2 Description
- 1.3 Dimensions
- 1.4 Specifications
- 1.5 Abbreviations
- 1.6 Product Labels
 - 1.6.1 Bucky Stand
 - 1.6.2 Tube Stand & Patient Table

Chapter 2 Installation

- 2.1 Introduction
- 2.2 Packaging Information
 - 2.2.1 Packaging Dimensions & Weight
 - 2.2.2 Unloading Crates
 - 2.2.3 Crate Opening
 - 2.2.4 Packaging Layouts & Details
 - 2.2.4.1 Tube Stand & Bucky Stand
 - 2.2.4.2 Patient Table
 - 2.2.5 Unpacking Products
 - 2.2.5.1 Removing Transportation Jigs
- 2.3 Room Layout
- 2.4 Drill Template (Anchor Bolt Holes)
- 2.5 Input Power & Grounding
- 2.6 Overview

- 2.6.1 Equipment Safety
- 2.6.2 Required Personnel
- 2.6.3 Tools
- 2.6.4 Room Preparation
- 2.7 Unpacking Non-Assembled Parts
- 2.8 Tube Stand Installation
 - 2.8.1 Floor Level Adjustment
 - 2.8.2 Rail Top Cover Installation
 - 2.8.3 Rail End Cover Installation
 - 2.8.4 Assembling Tube Stand & Rail
 - 2.8.5 Tube Rail & Cable Chain Installation
 - 2.8.6 Tube Arm & Stand Installation
 - 2.8.7 X-Ray Tube & Collimator Installation
 - 2.8.8 Spring Balancer Adjustment
 - 2.8.9 Tube Stand Level Adjustment
 - 2.8.10 Adjusting Tube Alignment
 - 2.8.11 Adjusting Control Panel Level
 - 2.8.12 Adjusting Tube Stand Magnet Brake
- 2.9 Bucky Stand Installation
 - 2.9.1 Converting to Right-Hand Load
- 2.10 Bucky Enclosure
 - 2.10.1 Bucky Structure (DR Panel Type)
 - 2.10.2 Bucky Structure (Cassette Type)
- 2.11 Connecting Cables
 - 2.11.1 Tube Arm & Tube Stand Cable Connections
 - 2.11.2 Tube Stand & Rail Cable Connections
 - 2.11.3 Connecting Foot Switch, CAN, and Power Cables
 - 2.11.4 CAN Connections

Chapter 3 Operation

- 3.1 Introduction
- 3.2 Power On / Off
- 3.3 System Operation
 - 3.3.1 Operating Bucky Stand
 - 3.3.1.1 Bucky Stand Movements
 - 3.3.2 Operating Tube Stand
 - 3.3.2.1 Control Panel
 - 3.3.2.2 Tube Stand Movements
 - 3.3.2.3 Information of Display
 - 3.3.3 Auto-Tracking Feature (Chest Position)

Chapter 4 Calibration

- 4.1 Introduction
- 4.2 Calibration Procedure
 - 4.2.1 Entering Calibration Mode
 - 4.2.2 Procedure & Description

Chapter 5 Periodic Maintenance

- 5.1 Introduction
- 5.2 Maintenance Schedule
 - 5.2.1 Operator Tasks
 - 5.2.2 Service Tasks

Chapter 6 Illustrated Parts List

- 6.1 Introduction
- 6.2 Electronic Parts
 - 6.2.1 References
- 6.3 Mechanical Parts
 - 6.3.1 Bucky Stand
 - 6.3.2 Tube Stand
 - 6.3.3 Tube Stand Rail
 - 6.3.4 Patient Table (Option)

Chapter 7 Electrical Schematics

- 7.1 Introduction
- 7.2 Block Diagram
- 7.3 Schematics
 - 7.3.1 OP Board
 - 7.3.2 Main Board
 - 7.3.3 Sensor Board
 - 7.3.4 Encoder
 - 7.3.5 PTN Board
 - 7.3.6 Connector Board

Safety Information

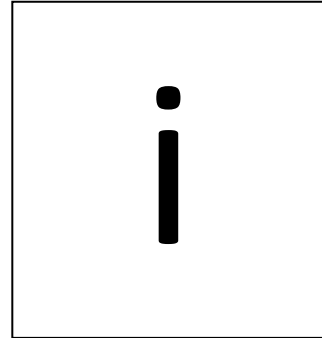

Introduction





The policy of SYFM Co., Ltd, is to manufacture X-ray equipment that meet high standards of performance and reliability. We enforce strict quality control techniques to eliminate the potential for defects and hazards in our products.

The intended use of this equipment is to provide a sub system for positioning an X-ray source and X-ray bucky for the purpose of acquiring X-ray images of the desired parts of a patient's anatomy. Use of this equipment in any other fashion may lead to serious personal injury.





The safety guidelines provided in this section of the manual are intended to educate the operator on all safety issues in order to operate and maintain the crane in a safe manner.

General Symbols



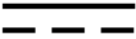

This manual uses three types of messages to emphasize information or potential risks to personnel or equipment. To ensure safety, read all Safety Information provided herein and observe all.

Symbols	Description
	<p>General mandatory action sign: To signify a mandatory action</p>
	<p>Refer to instruction manual/booklet: To signify that the instruction manual/booklet must be read</p>
	<p>General prohibition sign: To signify a prohibited action</p>
	<p>General warning sign: To signify a general warning. An instruction that draws attention to the risk of injury or death.</p>
	<p>Caution: An instruction that draws attention to the risk of damage to the product or proper use of the product.</p>
<p>Note</p>	<p>Note: Provides additional information such as expanded explanations, hints or reminders</p>



Electric & Electronic Symbols

Symbol	Description (IEC 60687/IEC 60417)	Number
	"ON" (power): To indicate connection to the mains, at least for Mains switches or their positions, and all those cases where safety is involved.	5007
	"OFF" (power): To indicate disconnection from the mains, at least for mains switches or their positions, and all those cases where safety is involved.	5008
	Alternating current: To indicate on the rating plate that the equipment is suitable for alternating current only; to identify relevant terminals.	5032
	Direct current: To indicate on the rating plate that the equipment is suitable for direct current only; to identify relevant terminals.	5031
	Grounding: Marked at the ground connected location.	5019

Packing Symbols

Symbol	Description (ISO 7000)	Number
	Fragile, handle with care	0621
	Keep dry	0626
	This way up	0623
	Temperature limitation	0632
	Humidity limitation	2620

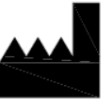
Label Symbols

Symbol	Description (ISO15223-1)	Number
	Manufacturer	3082
	Date of manufacture	2497
	Serial number	2498

General Safety

Numerous design features, operational safeguards and mechanical and electrical interlocks have been incorporated into this product's design for the safety of both the operator and patient and to protect the equipment from damage.

Note

Personnel operating and maintaining this product should receive training and be familiar with all aspects of operation and maintenance. To ensure safety, read this **SAFETY** section thoroughly before using the equipment and observe all **WARNINGS, CAUTION** statements and **NOTE** located throughout the manual.

Note

Only a qualified, authorized Service Provider should service/repair electrical or mechanical components.

The following are general safety precautions:

- Do not remove any covers for any purpose.
- Do not defeat or bypass built-in equipment safety features.
- Do not attempt any repairs if the equipment fails to operate correctly. Immediately call a qualified person authorized to repair the equipment.
- Do not attempt to relocate the equipment, or connect or disconnect any communication cables. Call a qualified person authorized to alter the equipment before attempting to relocate the equipment.
- Observe all warnings and cautions, stated or implied in procedures.
- Follow all safety labels on the equipment.
- Carefully read the product manual before operating the equipment.

Note

Follow all local, state and Federal guidelines and regulations on the disposal of hazardous material(s).

Electrical and Mechanical Safety

Only a qualified, authorized Service Provider should replace electrical or mechanical components.

◆ Electrical Safety

Sources of potentially lethal voltages/currents are physically and electrically isolated from both the operator and patient by insulated cables and mechanically secured covers and access panels.

- Do not remove any panels, for any reason.
- Do not expose, in any way, cables or their mating sockets.

◆ Mechanical Safety

The following are mechanical safety precautions:

- Keep fingers, hands and tools clear of moving parts.
- Always maintain observance of the patient position while positioning the equipment.
- Always maintain observance of other equipment in the area while positioning the equipment to prevent collision and potential damage.
- Unless specifically instructed, do not operate equipment with any covers removed.

User Maintenance / Servicing

Unless specifically instructed herein, all maintenance and serving of the equipment should be performed by qualified, authorized Service Providers. None of the electronic assemblies, cables or mechanical assemblies are user serviceable.

◆ Cleaning and Disinfecting

Some cleaning solutions, disinfectants and other chemicals can be destructive to the equipment or pose a risk of fire. The manufacturer is not responsible for damages or injuries that may result from the use of non-authorized chemicals on or near the equipment.



Warning

Do not operate the equipment when cleaning the equipment.
Before cleaning the equipment, please turn the power off.



Caution

Do not spray cleaning solution directly onto the equipment. Moisten a cloth with a 70% isopropyl alcohol solution for use on plastics and enameled metal. Apply to patient contact areas after each contact.



Caution

Do not immerse the equipment in liquid, do not autoclave equipment.

Hardware / Software Modifications

The equipment is complete as installed. The addition or subtraction of hardware or software not authorized by the manufacturer can lead to:

- ◆ Potential health risk to operator and/or patient.
- ◆ X-Ray imaging artifacts that can interfere with proper image interpretation.
- ◆ Equipment malfunction and/or damage.



Warning

Do not try to defeat or bypass built-in safety features.



Warning

Do not try to move equipment or disconnect any communication or power cables. Refer such actions to qualify authorized personnel only.



Warning

Follow all safety labels placed on the equipment.

Environmental Safety and Operating Environment

The equipment is designed to operate in ambient air, free of corrosive compounds. The manufacturer is not responsible for injury or damages resulting from any equipment exposed to flammable or flame promoting gases (ether, alcohol or an oxygen enriched environment).

The following environmental conditions are appropriate for the equipment. Operation under conditions outside of these ranges could damage the equipment.

PARAMETER	LIMITS
Acceptable Temperature Range	5°C to 30°C or 41°F to 86°F
Acceptable Relative Humidity	10% to 75% (non-condensing)

**Warning**

Operate the equipment outside of its operating environment limits may lead to malfunction of or damage to the equipment.

Manufacturer's Responsibility

Allow only authorized, properly trained personnel to operate the equipment. Ensure that all individuals authorized to use the equipment are aware of the danger of excessive exposure to X-Ray radiation.

This equipment is sold with the understanding that the manufacturer, its agents, and representatives do not accept any responsibility for overexposure of patients or personnel to X-Ray radiation. No responsibility is assumed for any unit that has not been serviced by qualified authorized service personnel.

Introduction

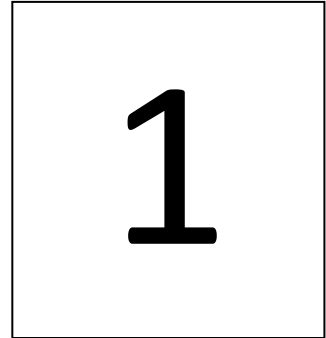

1.1 Introduction

This manual provides installation, service and operation information for SST-3100.

1.2 Description

SST-3100 is a mechanical subsystem requires to be integrated into a radiographic system.

SST-3100 has been designed and developed for various X-ray examination techniques in proper examination circumstances.

1.3 Dimensions

Refer to the following drawing for the dimension of the entire system.

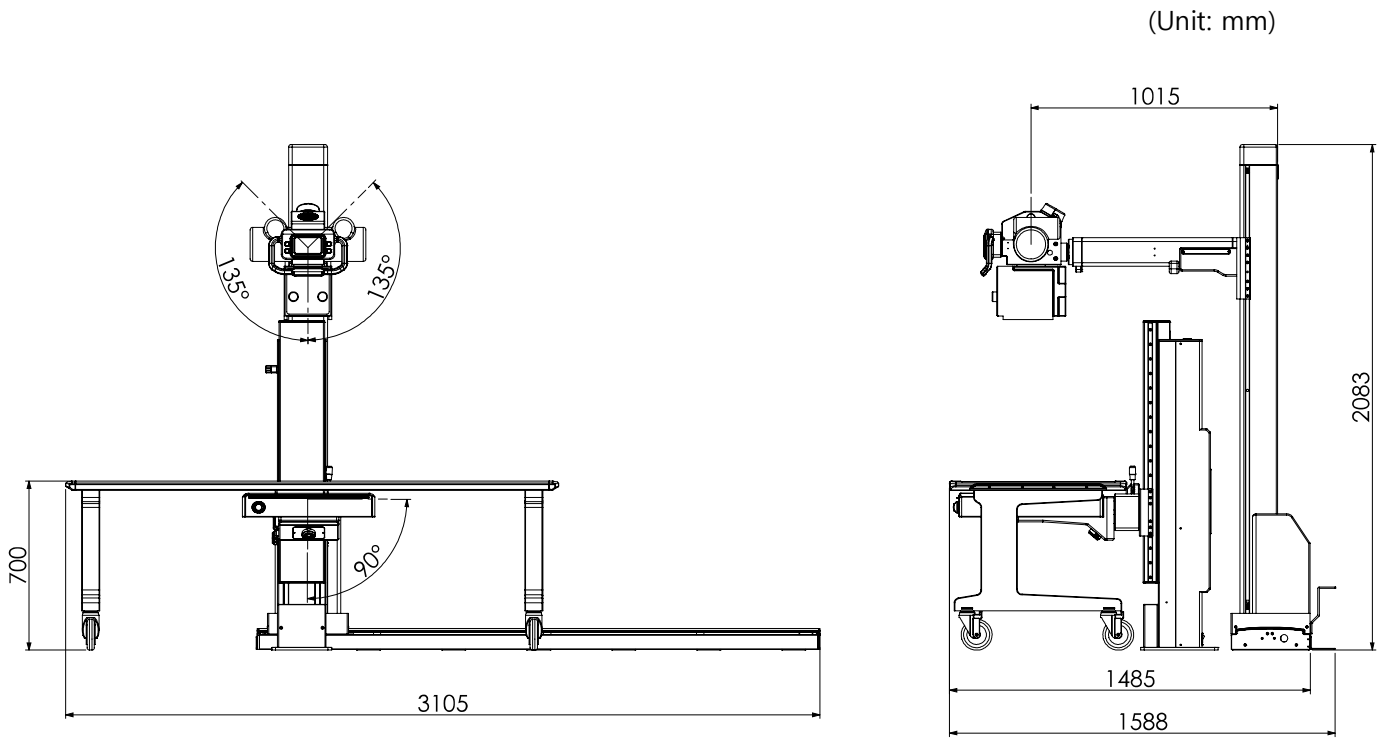

Figure 1-1. System Dimensions

1.4 Specifications

Refer to the following table for the specifications and details of the system.

Floor Mounted Tube Stand (Manual & Motorized)	
Display with 5" screen on the tube housing.	
Workflow is enhanced through direct manipulation of examination parameters listed below.	
<ul style="list-style-type: none"> ● SID (Source-image distance) measurement ● Display angle of tube rotation 	
Movements	Vertical / Longitudinal travel controlled by electric magnet brake
	Tube rotation: $\pm 135^\circ$
Travel Range	Vertical (Tube): 149 cm ± 1 cm
	Longitudinal (Column): 190 cm ± 1 cm
Power Requirement	24 VDC, 3A
Bucky Wall Stand (Motorized)	
The stand can be equipped with cassettes or a mobile flat detector for optimal coverage and high patient throughput.	
Motorized Movement	Vertical travel with electric magnet brake
Vertical Travel Range (central beam - floor)	135 cm
Bucky Rotation Range	$0^\circ \sim 90^\circ$
Power Requirement	24 VDC, 1A
Mobile Patient Table (*Option)	
Mobile: Individual locking casters	
Table Top Dimension	197 x 72.8 x 70 cm
Table Height	70 cm
Max. Patient Load	250 kg

Table 1-1. Specifications

1.5 Abbreviations

%	Percent
AWG	American Wire Gauge
Btu	British Thermal Unit
°C	Degree Celsius
CE	Communautés Européenes
cm	Centimeter
C.R.S	Cold Rolled Steel
°F	Degree Fahrenheit
ga	Gauge
hPa	Hecto Pascal
inHg	Inches Mercury
Kg	Kilogram
kJ	Kilojoule
Lb	Pound
M	Meter
max.	Maximum
min.	Minimum
mm	Millimeter
Sq/Ft	Square Foot
Sq/M	Square Meter
UL	Underwriters Laboratories

1.6 Product Labels

Refer to the follows for the product labels of the system.

1.6.1 Bucky Stand

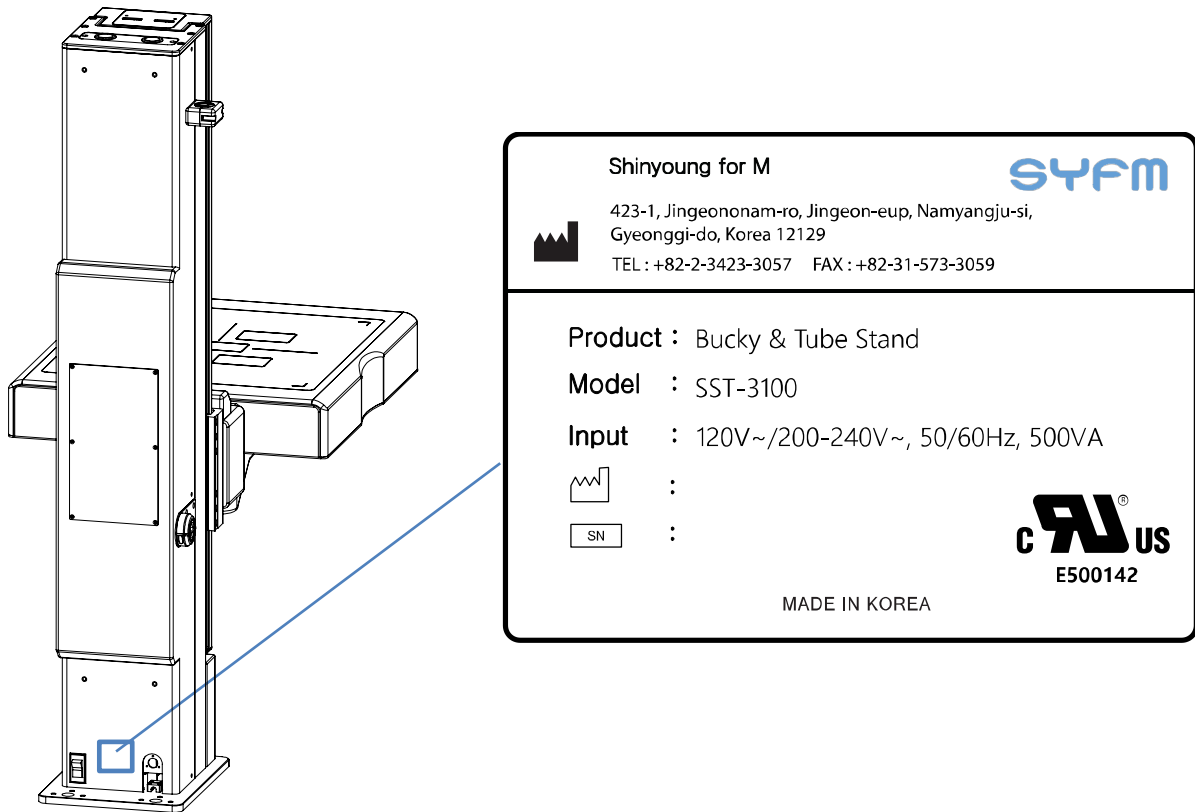
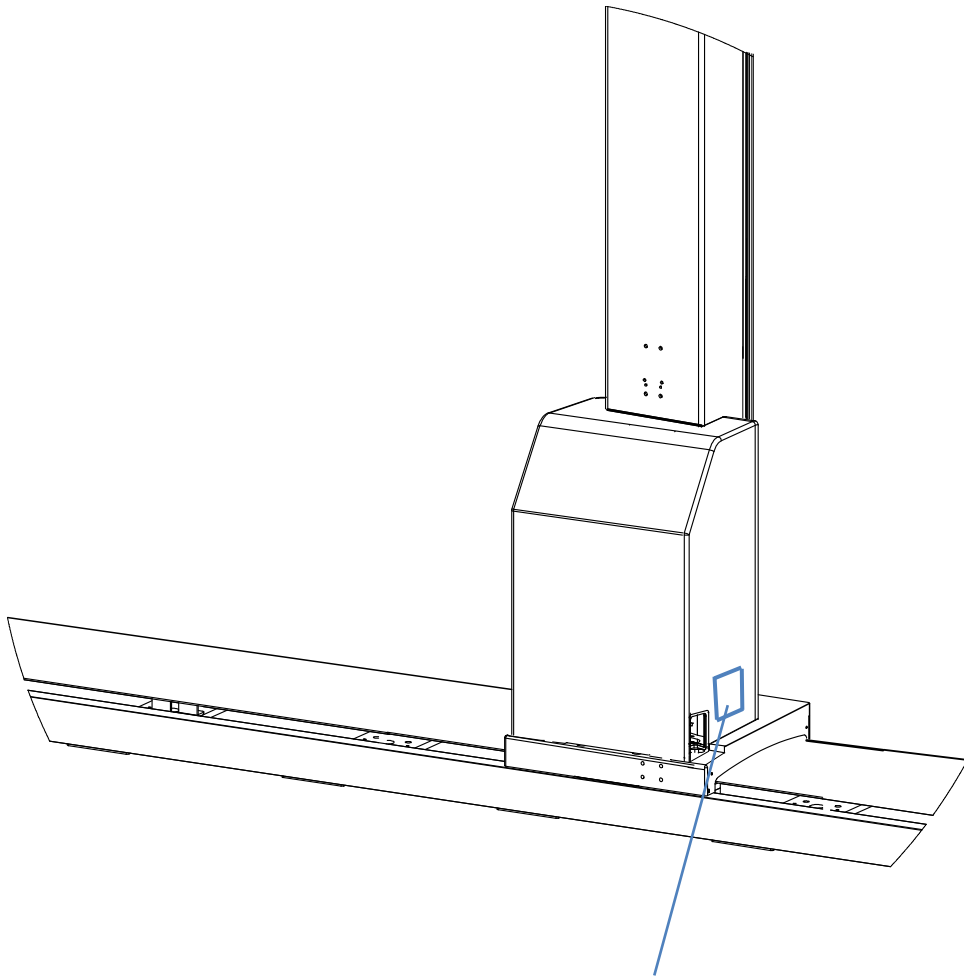

Figure 1-2. Product Label & Location (Bucky Stand)

1.6.2 Tube Stand & Patient Table







Shinyoung for M		SYFM
	423-1, Jingeononam-ro, Jingeon-eup, Namyangju-si, Gyeonggi-do, Korea 12129 TEL : +82-2-3423-3057 FAX : +82-31-573-3059	
Product : Bucky & Tube Stand		
Model : SST-3100		
Input : 120V~/200-240V~, 50/60Hz, 500VA		
	:	
	:	
MADE IN KOREA		 E500142

Figure 1-3. Product Label & Location (Tube Stand)

Installation

2

2.1 Introduction

This chapter includes necessary information and details from unloading and unpacking to the installation of the system. SST-3100 is consisted of a tube stand with a rail, a bucky stand, and a patient table which are packed into wooden crates.

To unpack the wooden crates before installation, use required tools as following:

◆ Required Tools

- Standard Service engineer tool kit
- Electric drill motor and assorted bits



Warning

At least 2 persons are required for removing and lifting heavy components, safe installation.

2.2 Packaging Information

All the items are packed into wooden crates for safe transportation.

It is necessary to learn about the information and details from unloading to unpacking of the system.

2.2.1 Packaging Dimensions & Weight

The overall information of packaging dimensions and weight are as follows.

Packed items	Dimension (cm)	Weight (kg)
Tube Stand + Bucky Stand	265 x 110 x 80 cm	550 kg
Patient Table (*Option)	216 x 90 x 15 cm	90 kg

Table 2-1. Packaging dimensions and weight

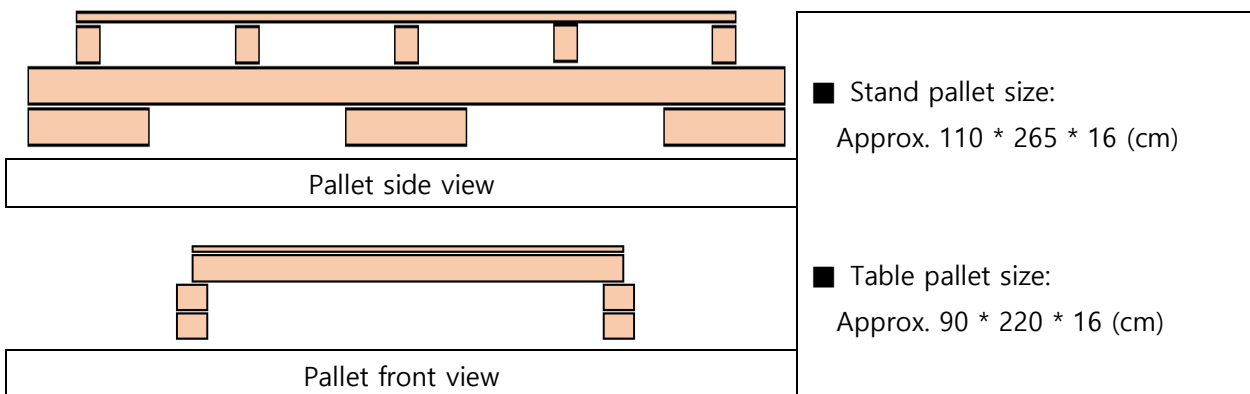

Figure 2-1. Pallet views and dimensions

Note

The packaging method can be changed depending on each terms and conditions.

2.2.2 Unloading Crates

The wooden crates of all products are manufactured in a structure that can be lifted in all directions using a forklift.



Figure 2-2. Lifting Directions

2.2.3 Crate Opening

In order to open up the crates, proceed with the following instruction in order.

- ① The highlighted parts with "BLUE" in the following figures are fixed with M8 x 50 Hexagon head screw + Nut + Washer for conveniency when opening the crates.

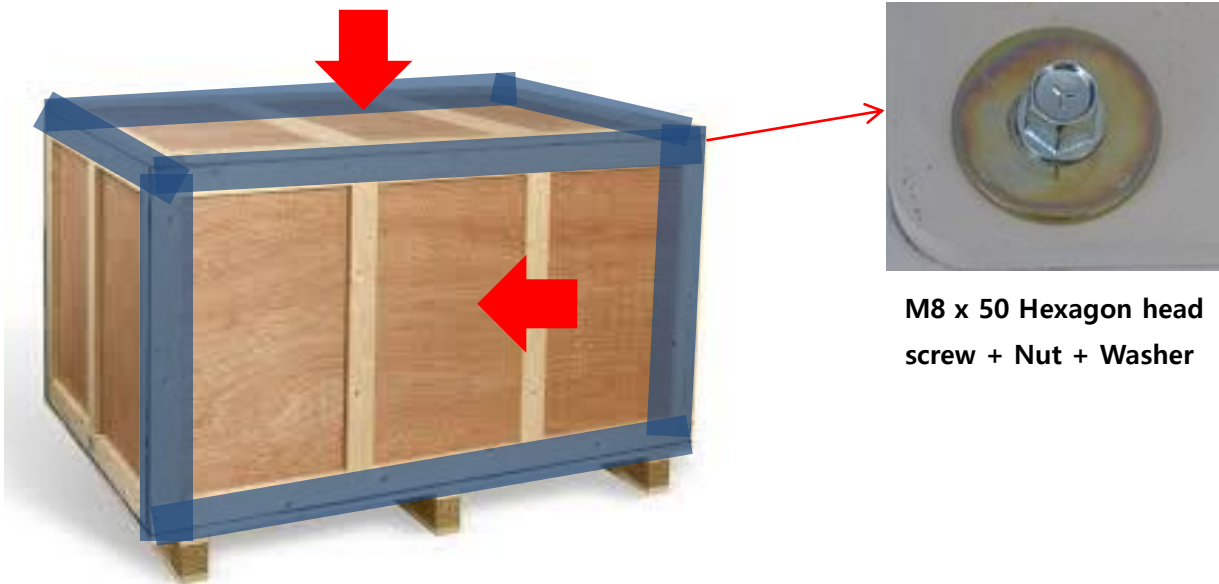

Figure 2-3. M8 x 50 Hexagon head screw + Nut + Washer

Note

Make sure to first find the parts fixed with M8 x 50 Hexagon head screw + Nut + Washer to remove the two wooden panels (pointed by red arrows) as described in the above. The rest parts are fixed with nails.

- ② After opening up the crate, there are products and parts packed with vacuum. Carefully open up the packaging with a cutter knife or a scissor not to damage the products inside.



Figure 2-4. Vacuum packaging

- ③ The following items will be visible after opening up the packaging and the stands are fixed with screws. Regarding the details and information of the screws, refer to "2.2.4 Packaging Layouts & Details".

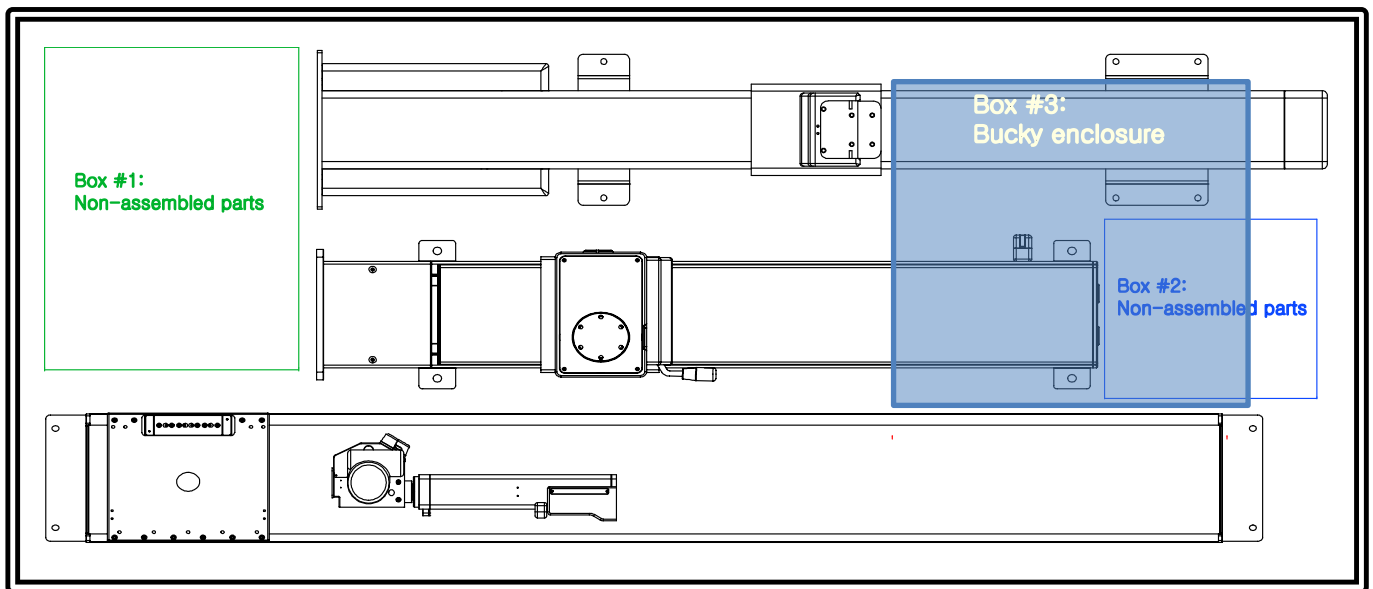

Figure 2-5. Components

2.2.4 Packaging Layouts & Details

The overall information of packaging layouts and details are as follows.

All the screws that are fixing the products inside the crates need to be removed to get the products out from the crates.

2.2.4.1 Tube Stand & Bucky Stand

Refer to the following information for the locations of the screws.

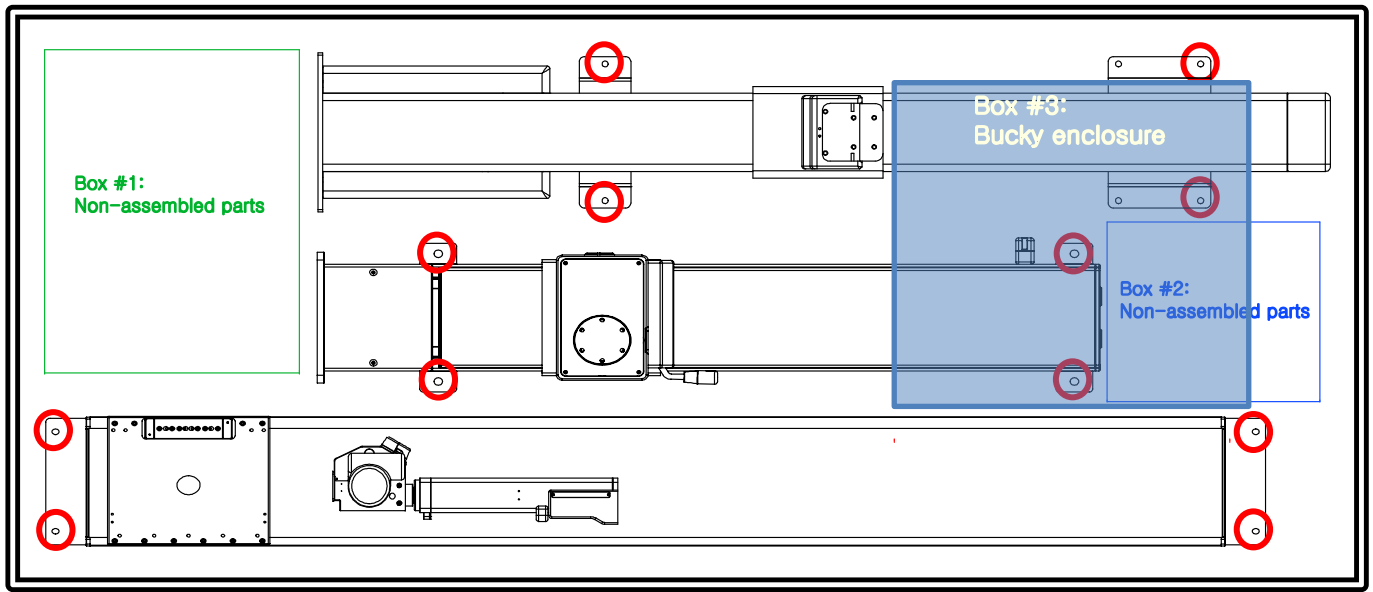

Figure 2-6. Packaging layout

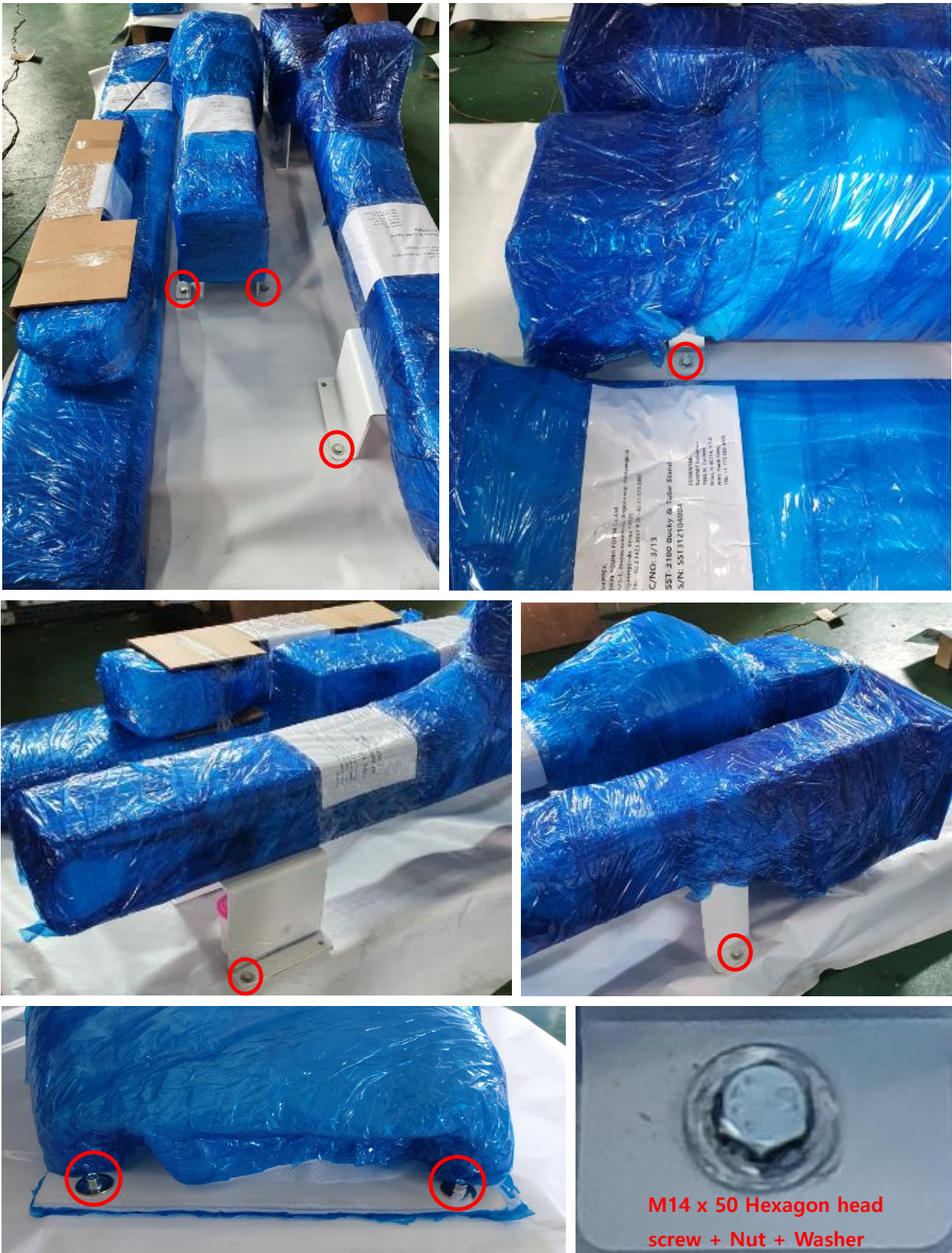

Figure 2-7. M14 x 50 Hexagon head screw + Nut + Washer

2.2.4.2 Patient Table (Option)

The patient table is optional. The patient table is basically packed into a paper box made of thick paper with high strength. Refer to the following pictures for the packaging information of the patient table.



Figure 2-8. Patient Table Packaging

2.2.5 Unpacking Products

It is required to remove the transportation jigs attached to each product after getting the products out from the crates.

2.2.5.1 Removing Transportation Jigs

Refer to the following information for the locations of the transportation jigs and removing the jigs.

- Bucky Stand

Unit: mm

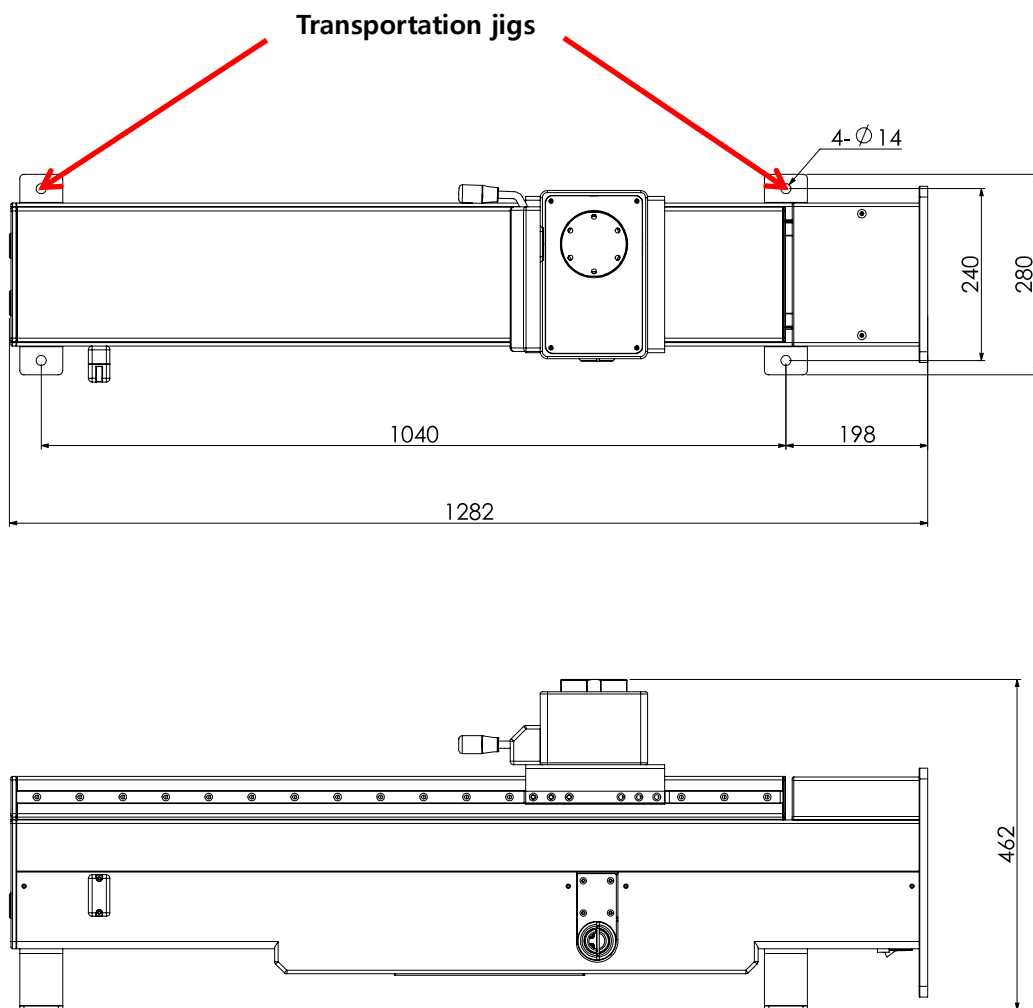

Figure 2-9. Transportation jig locations

Lift the stand with force and make it stand straight as the following figure and remove the jigs.

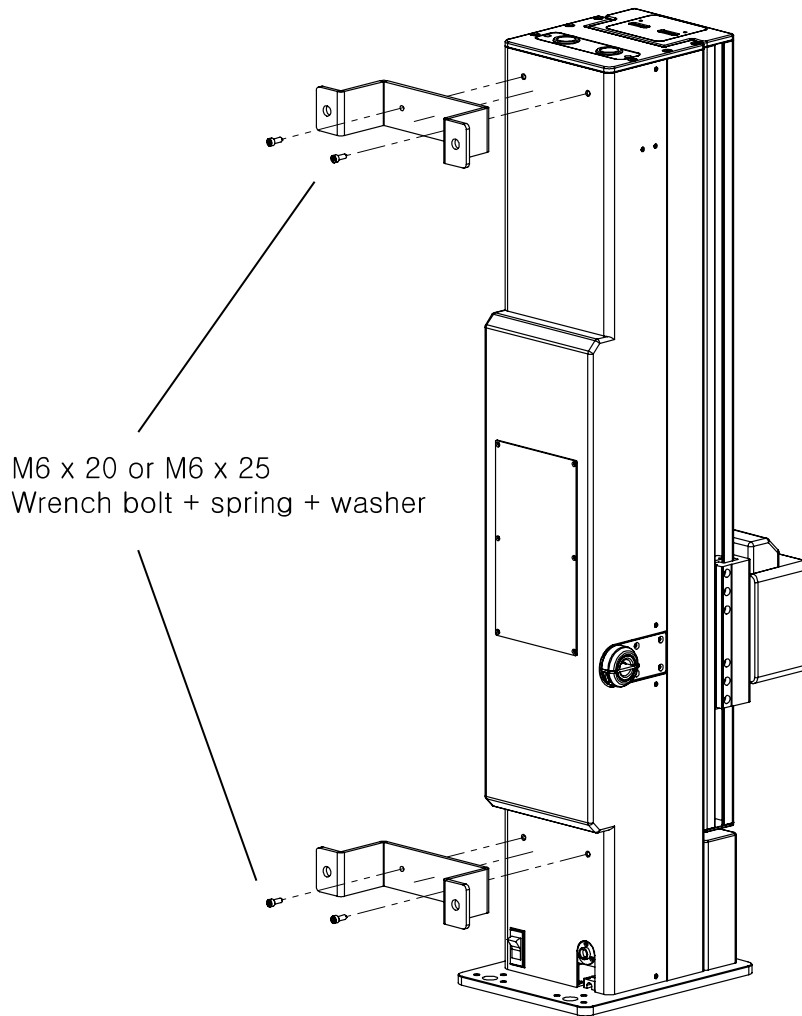

Figure 2-10. Transportation jig exploded view



Warning

At least 2 persons are required for lifting and carrying the stand for safety.

- Tube Stand (Column)

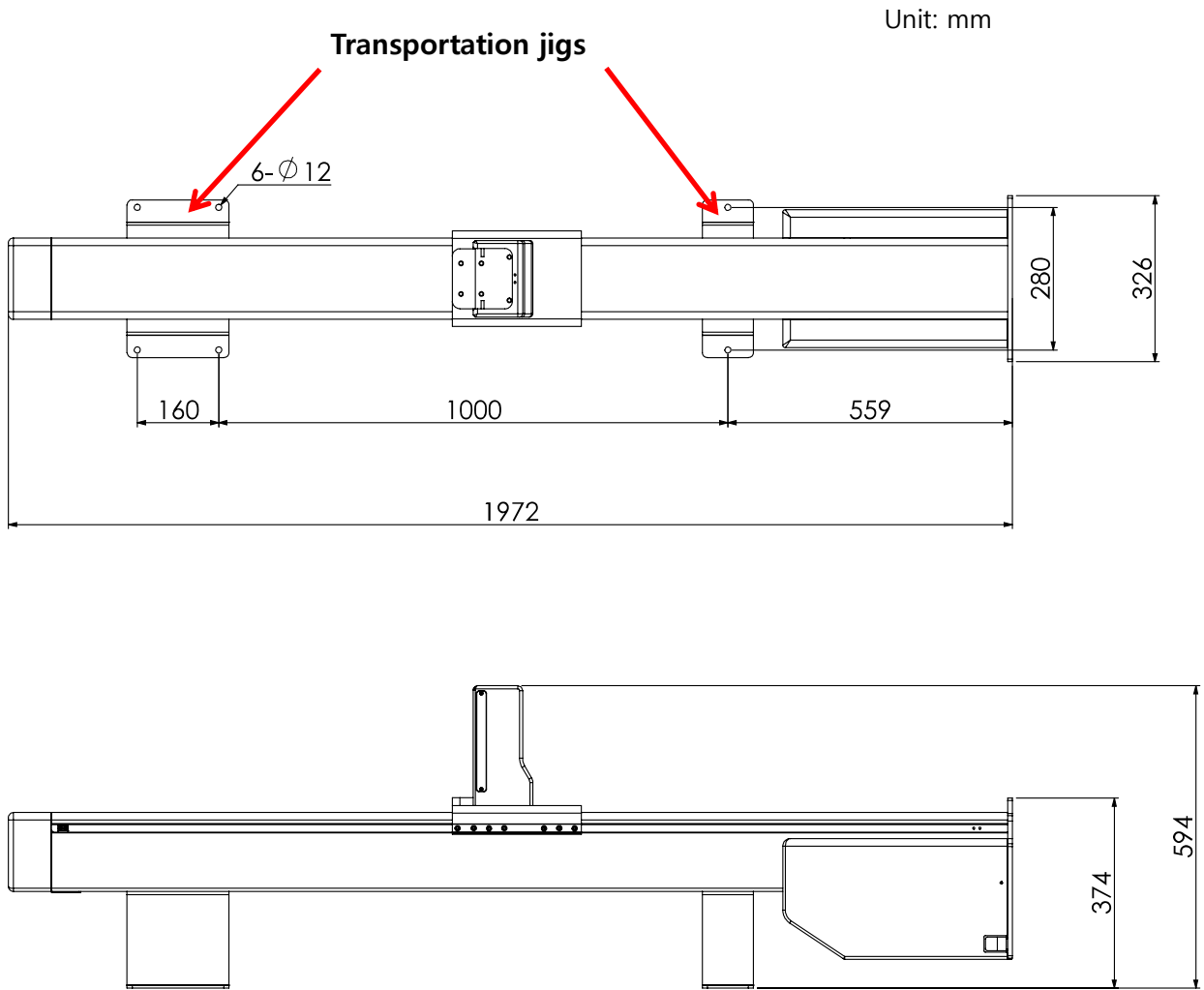

Figure 2-11. Transportation jig locations

Lift the stand with force and make it stand straight as the following figure and remove the jigs.

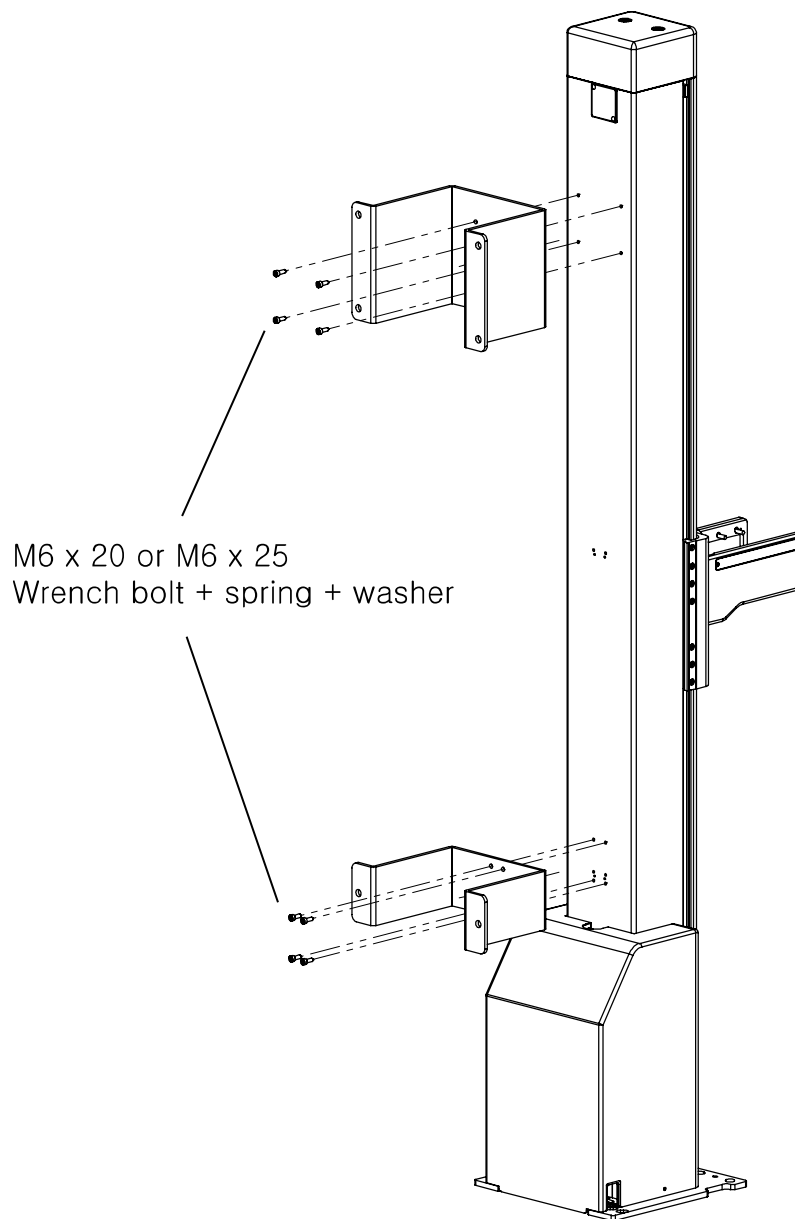

Figure 2-12. Transportation jig exploded view



Warning

At least 2 persons are required for lifting and carrying the stand for safety.

• Tube Stand (Rail)

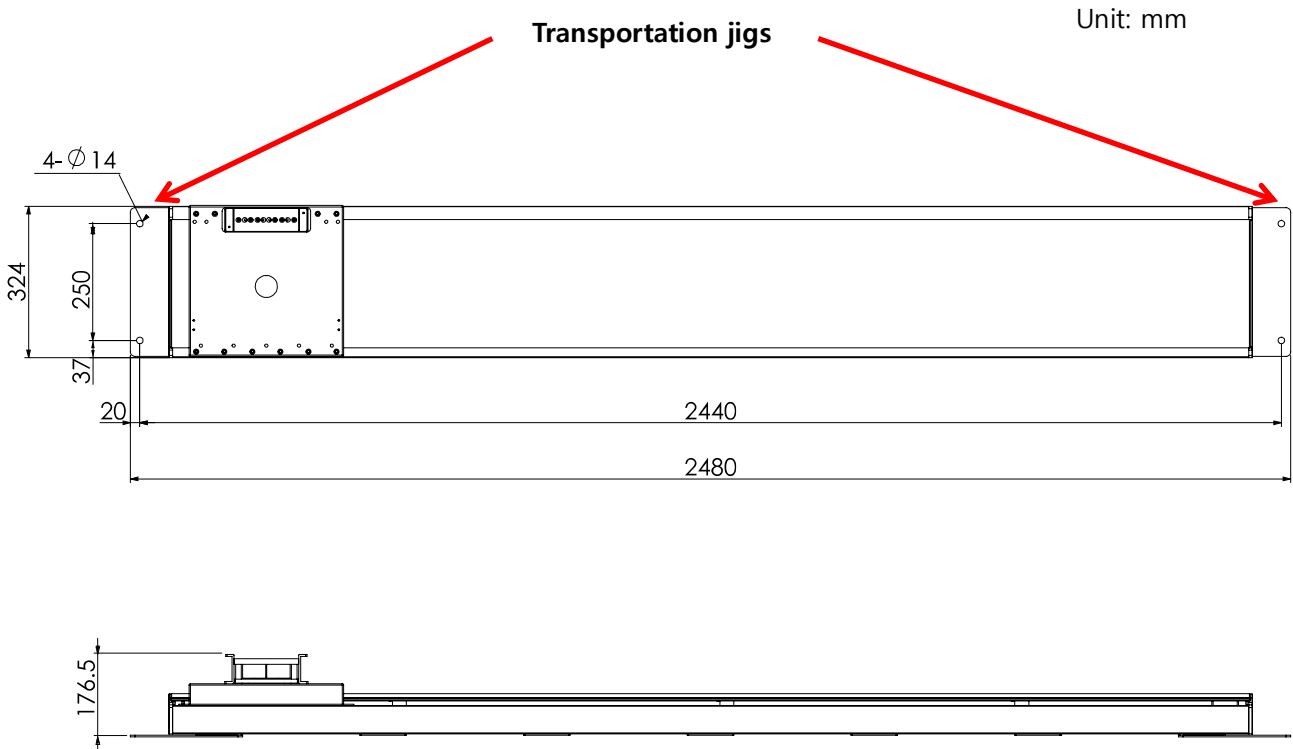

Figure 2-13. Transportation jig locations

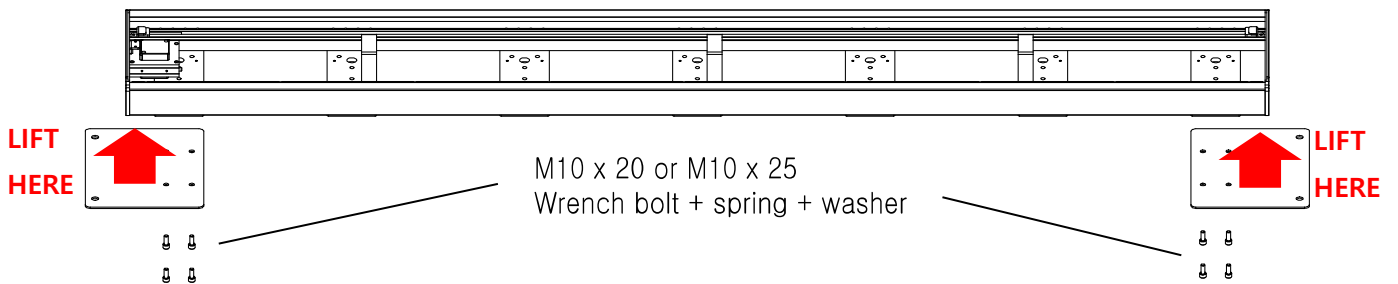

Figure 2-14. Transportation jig exploded view



Warning

At least 2 persons are required for lifting and carrying the rail for safety. While a person is lifting each side of the rail, another person needs to remove the jig.

2.3 Room Layout

Before installation, please measure recommended dimensions of exam room.

The following figure explains about the minimum space required to installed this system.

(unit: mm)

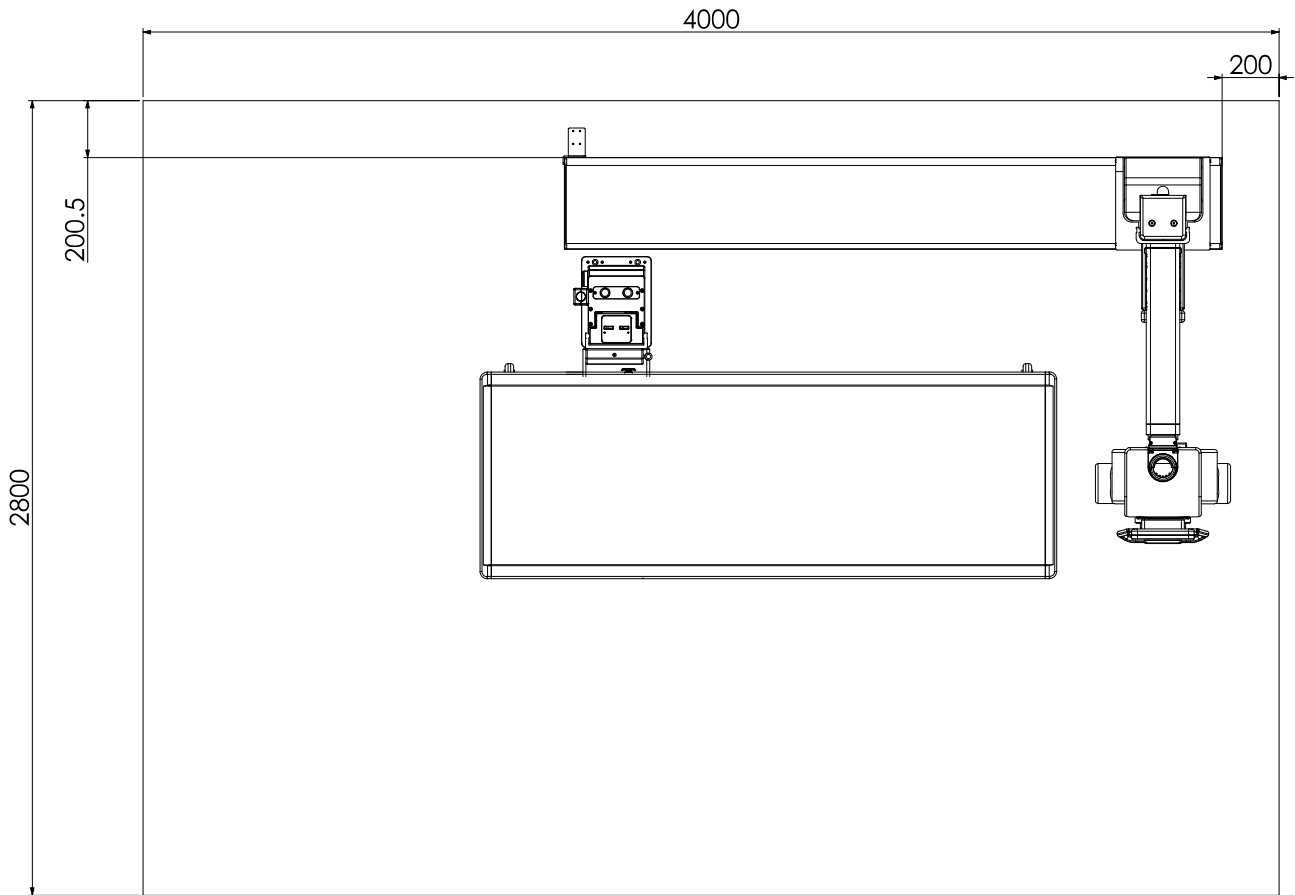

Figure 2-15. Room Layout

2.4 Drill Template (Anchor Bolt Holes)

The following drawing describes the locations of the base holes to fix the system to the floor with the anchor bolts described below.

(unit: mm)

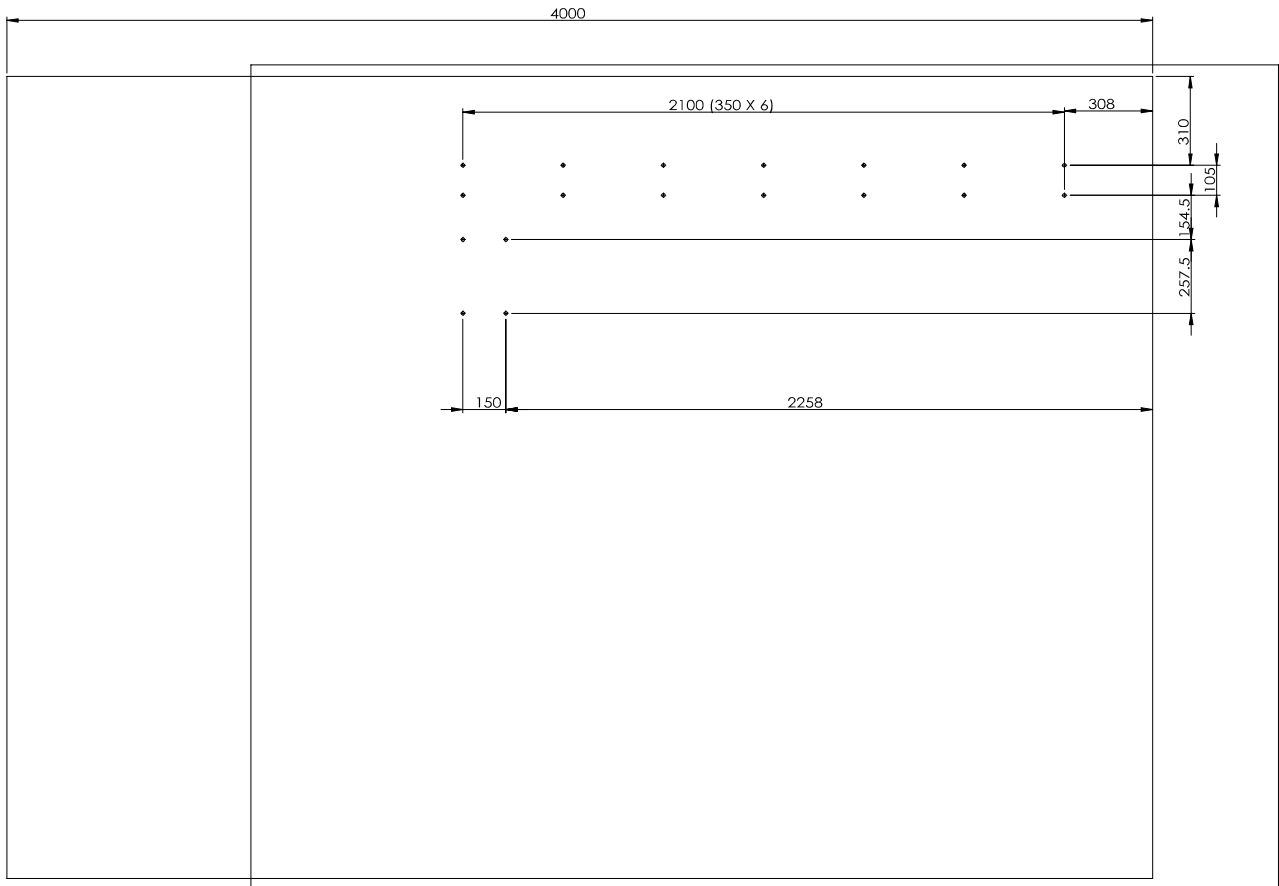

Figure 2-16. Base Anchor Bolt Hole Locations



Caution

It is very important to maintain level horizontally, so if the base floor is not guarantee a perfect horizontal level, then achieve it using some piece of sheet metal. It is very important to place the bucky stand to the location where perfectly aligned with the tube stand for achieving proper images.

2.5 Input Power & Grounding

Refer to the following figure for the input power and grounding of the system.

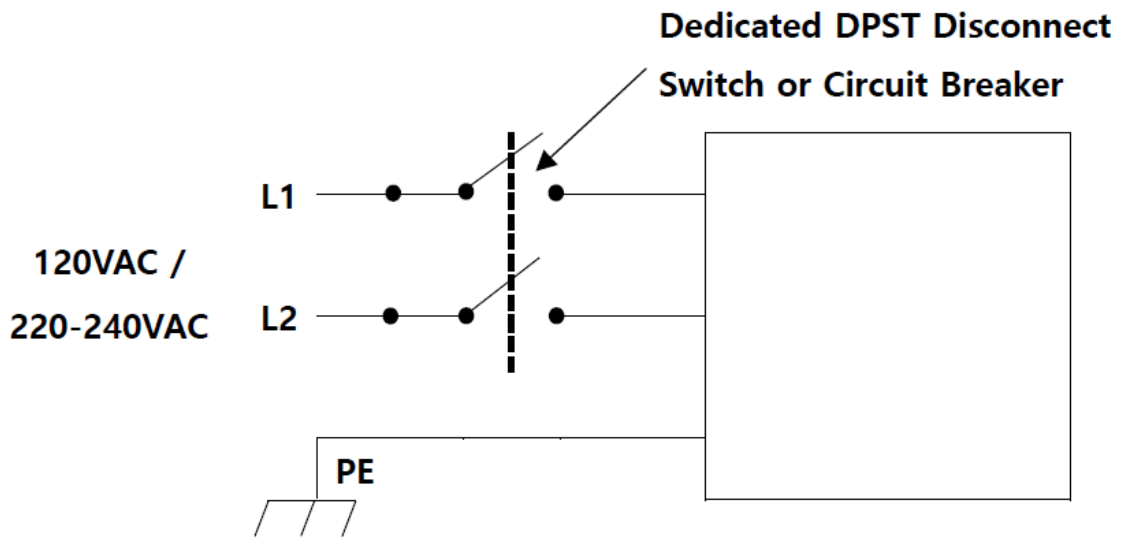

Figure 2-17. Input Power, 120-240V, 50/60Hz, Single phase

2.6 Overview

This topic details the tasks you must do before installation.

The topics covered are:

- Safety equipment needed
- Required Personnel
- Tools and needed equipment
- Room preparation

2.6.1 Equipment Safety

This system is consisted of a patient table, bucky stand, and tube rail stand. While installing this system, you must protect yourself from falling assemblies, tools, and miscellaneous fasteners and components that may cause serious injury to you and /or other installers in the room.

The following safety items must be worn during the installation.

- Safety hat
- Safety glasses
- Back support
- Safety shoes

2.6.2 Required Personnel

Do not attempt to install this equipment with less than two people - three people are preferable. Each person should wear the proper equipment safety attire during the installation.

2.6.3 Tools

Before starting the installation, ensure that you have the proper equipment to do the job.

- Required Tools
- Standard Service engineer tool kit
- Electric drill motor and assorted bits

2.6.4 Room Preparation

The following warnings must be complied with before installation begins.







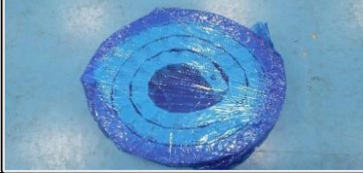
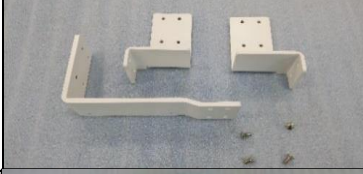

Warning

- Failure to comply with three warnings may cause serious or fatal bodily injury and degrade the unit's safety level.
 - Ensure that the central ground terminal of the room has a resistance in accordance with the regulations in force.
 - Ensure that the room emergency circuit is present and designed in accordance with the regulations in force.
 - A qualified facility official **MUST** approve the room before installation begins.
 - There should be sufficient clearance required between the equipment and the walls and doors, and so on.
-

2.7 Unpacking Non-Assembled Parts

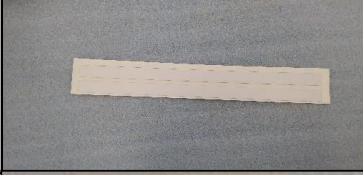
Below is a list of the components belong to this system which will be packed separately into an isolated box besides the machines.

No.	Description		Q'ty
1	Final Inspection Report		1 ea
2	Bucky assembly		1 set
3	Tube Rotor Cable (16# 6C X 12m)		1 ea
4	Cable chain		1 ea
5	Cable chain fixing brackets		1 set
6	Hose_Ø67 x 3m		1 ea
7	Hose Holder For Duct Hose (M5 X 10 Wrench Bolt 2 ea)		2 sets
8	Hose holder_Ø65		3 sets
9	Covering Sticker		2 ea
10	Base cover of Tube stand		1 set











11	<p>Adjusting plate for tube stand (1.2t=3, 2t=2)</p>		5 ea
12	<p>M4 X 10 Trus head cap screw</p>		4 ea
13	<p>M5x10 Hex Sockethead Bolt</p>		6 ea
14	<p>M5 X 12 Plate Screw</p>		8 ea
15	<p>M6x10 Plate Screw</p>		4 ea
16	<p>M6 X 16 Plate Screw</p>		4 ea
17	<p>M10 X 15 Set Screw</p>		8 ea
18	<p>Collimator Power Cable (16# 3C X 12m)</p>		1 ea
19	<p>Foot Switch</p>		1 ea
20	<p>Bucky mounting bracket</p>		1 ea

Table 2-18. Shipping Components

2.8 Tube Stand Installation

It is very important to first place the rail to a proper location considering conditions of each room because this is the beginning of the installation of the system.

2.8.1 Floor Level Adjustment

To adjust floor level, there are set screws fitted into the holes (red circled in below) in the base plate of the floor rail as described in the following figure.

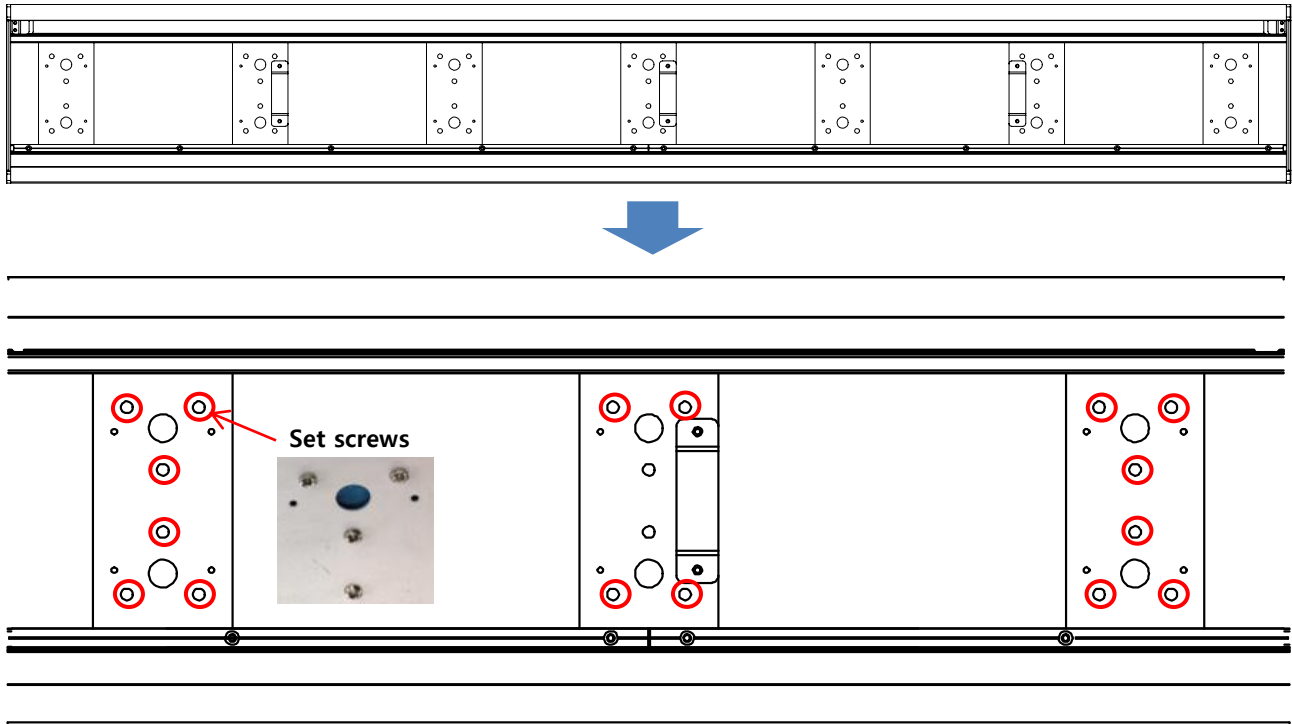

Figure 2-19. Floor Level Adjustment

2.8.2 Rail Top Cover Installation

There is a rail top cover per each rail that needs to be installed.

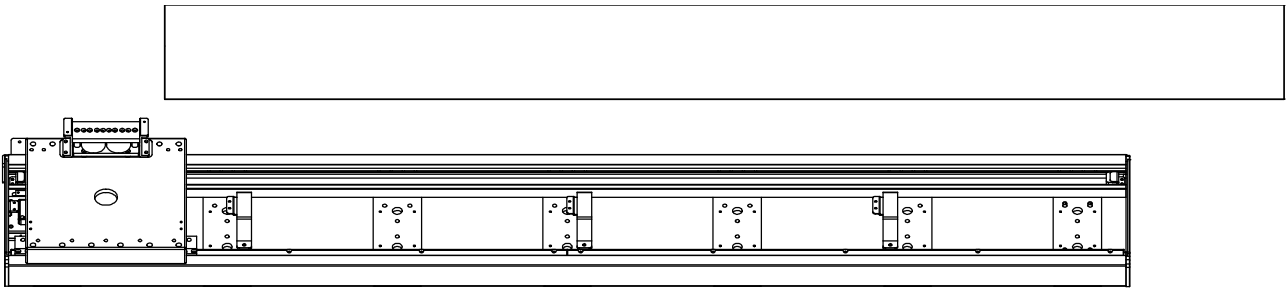

Figure 2-20. Rail top cover exploded view

- ① Move the stand carriage far enough either to left or right to be able to place the rail top cover easier. Then place the rail top cover on to the rail.

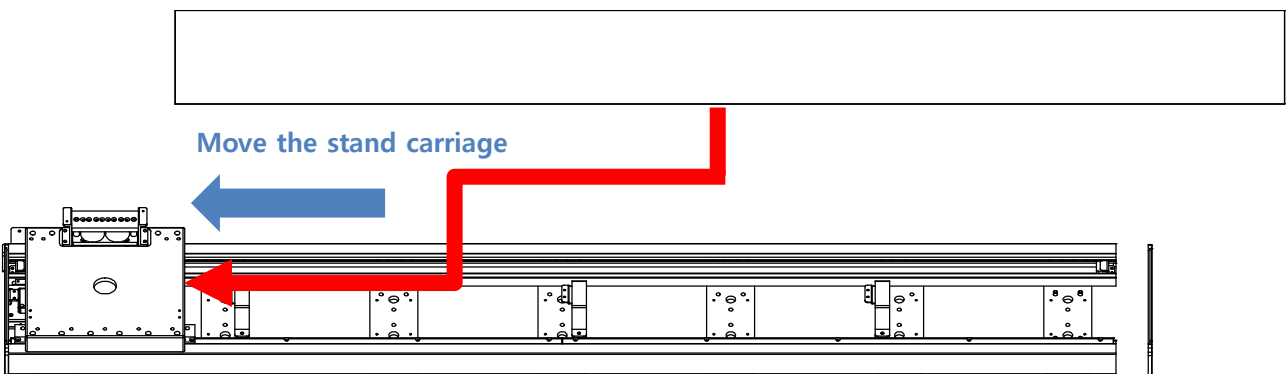

Figure 2-21. Rail top cover placing (1)

- ② After placing the rail top cover, there are two end covers should be installed to finish the rail installation. Refer to "2.8.3 Rail End Cover Installation" for more details.

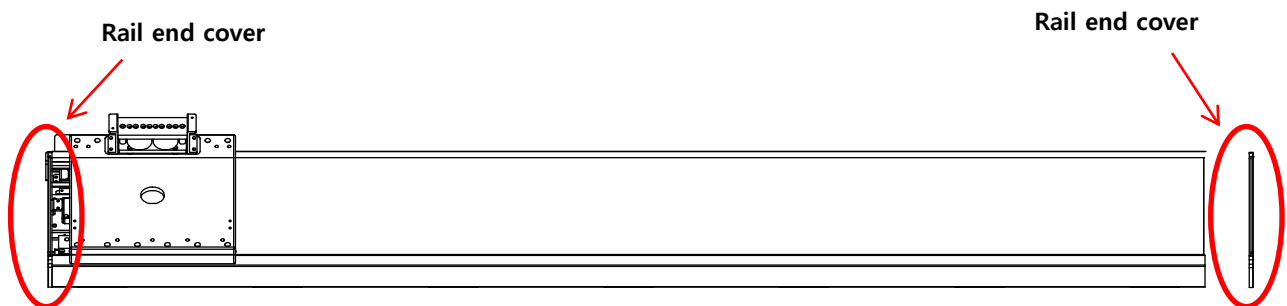
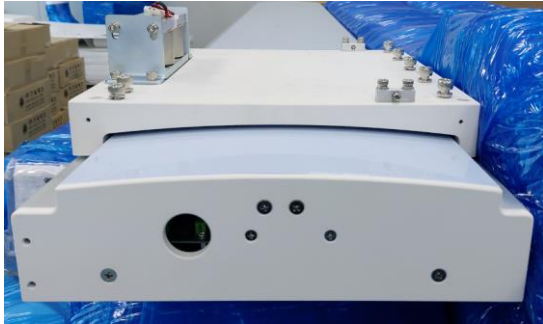

Figure 2-22. Rail top cover placing (2)

2.8.3 Rail End Cover Installation

After the rail top cover has been installed, install the rail end covers as shown on the images below. Each side cover has different shape and size, make sure to install the corresponding covers on each side.



< Left Side >



< Right Side >



Figure 2-23. Rail end cover installation

2.8.4 Assembling Tube Stand & Rail

Place the tube stand column on the rail to connect and assemble them using M8x20 bolts and engage the connectors (for magnet brake) matching the labelling.

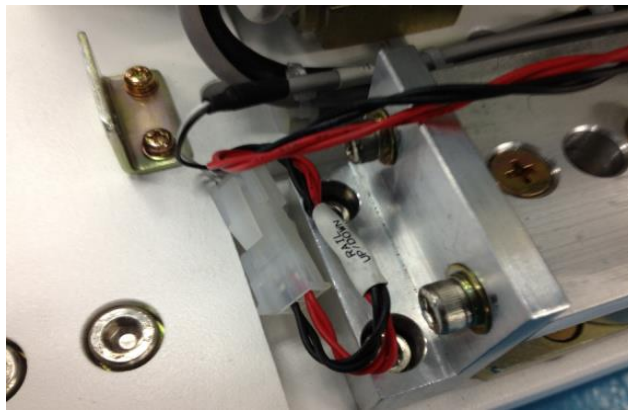
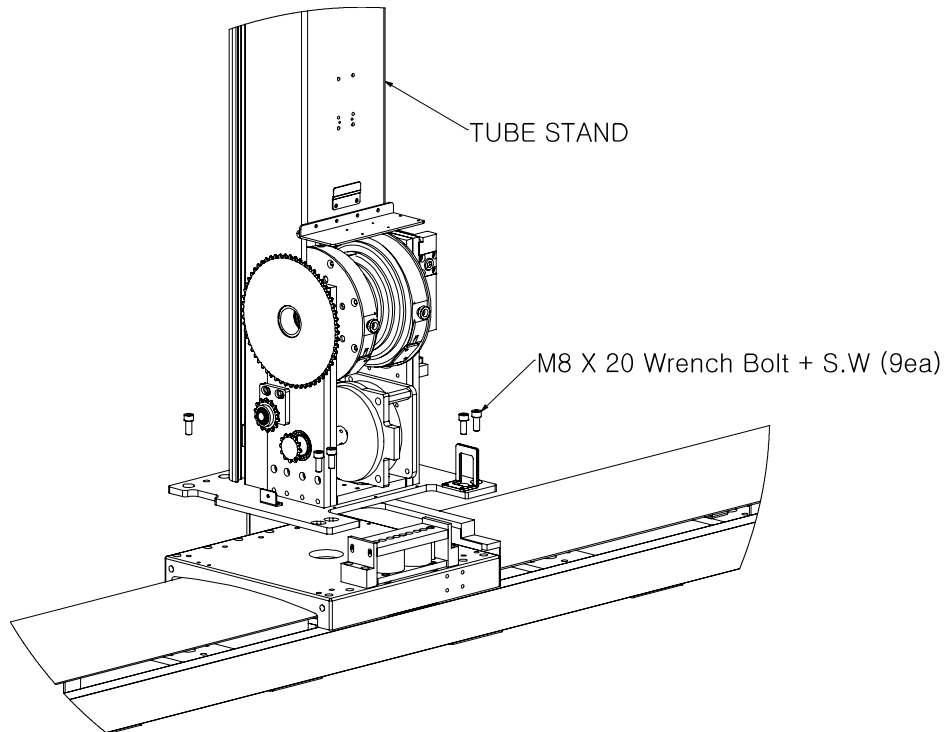

Figure 2-24. Tube stand & rail installation

Caution

Be careful to prevent cable pinching when the tube stand is being seated on the rail.

2.8.5 Tube Rail & Cable Chain Installation

There are two kinds of the fixing bracket required for installing the cable chain. Refer to the following pictures for the figure of the brackets and cable chains.

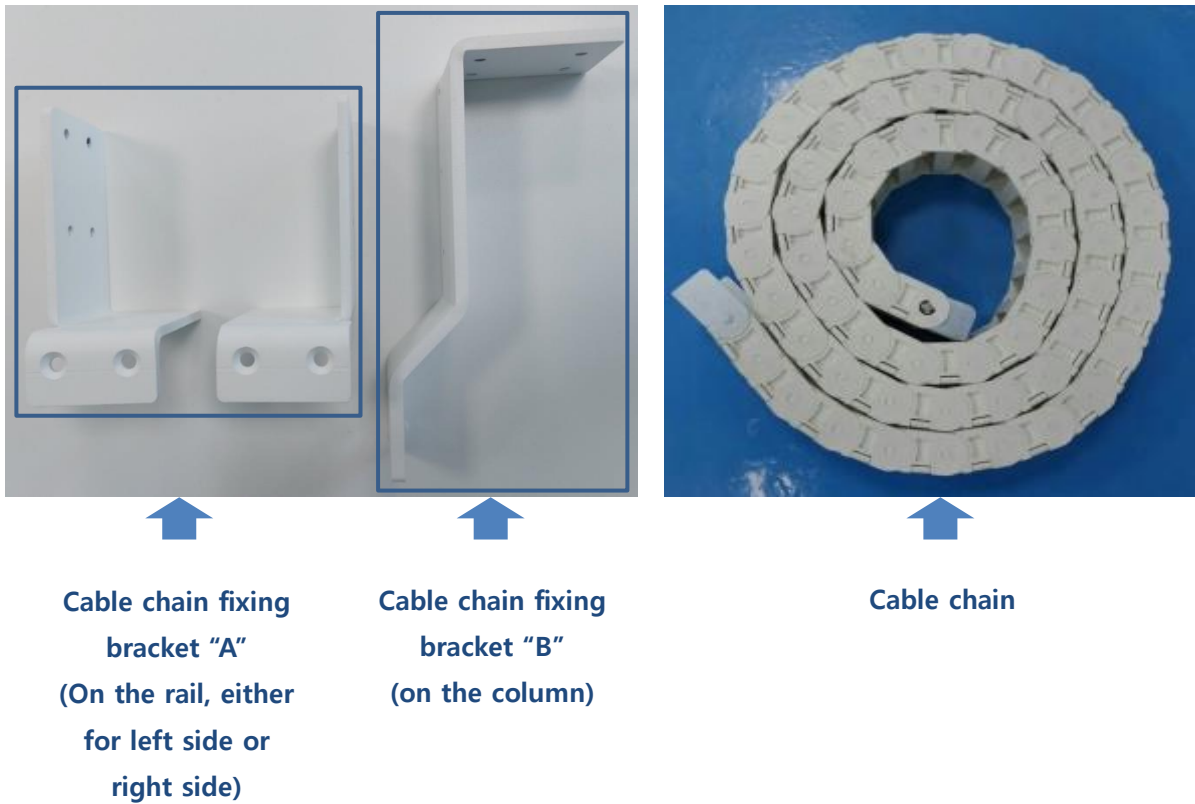

Figure 2-25. Fixing Brackets & Cable chain

- The bracket "A" is to be assembled to either the left end or right end of the rail depending on needs of customers or circumstances of each room.
- The bracket "B" is to be assembled to the tube stand column.
Use the provided flat headed bolts when assembling the brackets.
- After fixation of the brackets, install the cable chain referring the following pictures. Keep in mind that the flexible side end that is capable of moving up and down must be attached to the column.
- Assemble the cable chain to each bracket using the provided round headed bolts.

After the brackets have been put in place, install the cable chain referring the following pictures. Keep in mind that the flexible side end that is capable of moving up and down must be attached to the column.

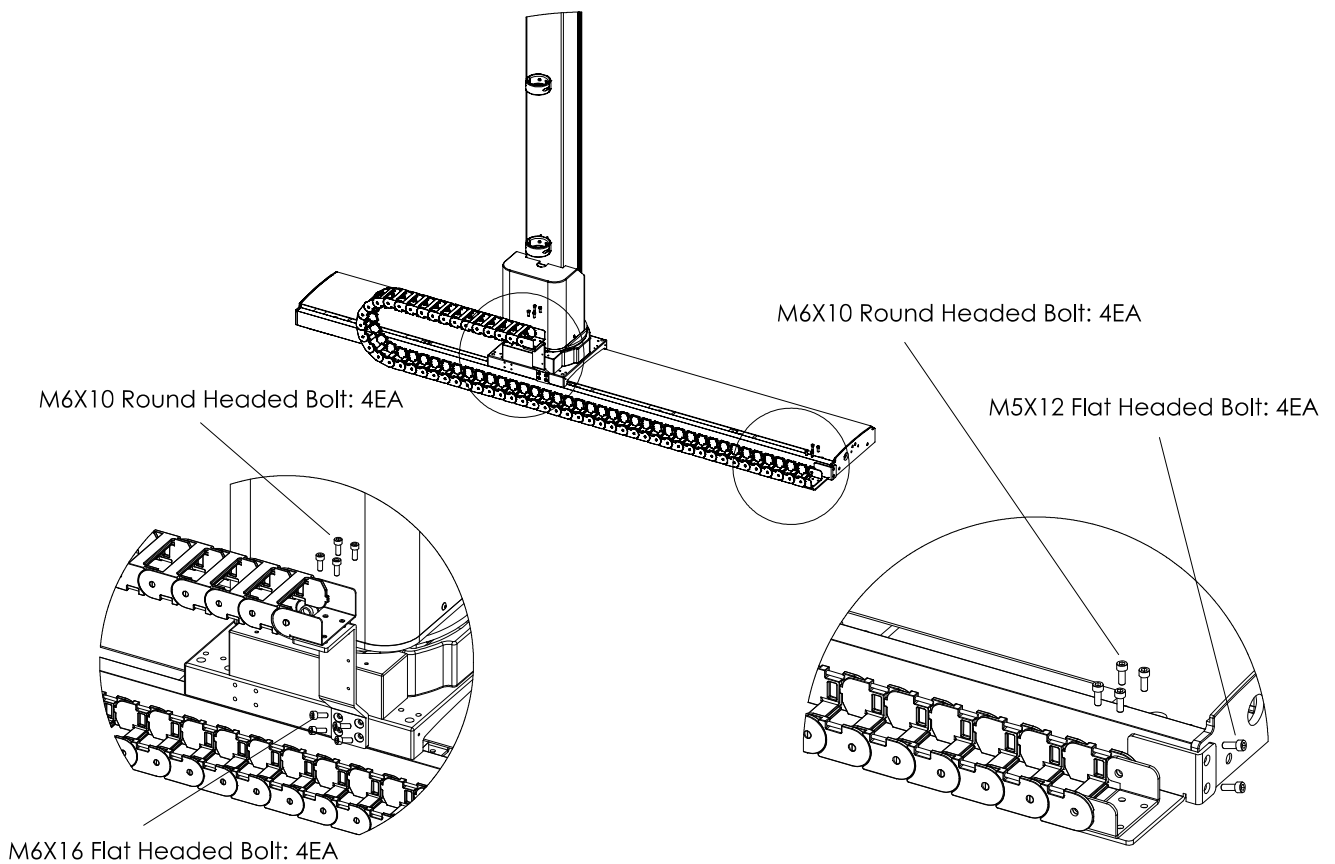

Figure 2-26. Brackets & Cable Chain Installation

Note

- There are two of the bracket "A" provided in the package.:
One is for fixing the bracket on the left end of the rail and another one is for fixing the bracket on the right end of the rail.
 - In case of installing the bucky stand to right side instead of left side, it is required to consider the route of the cables.
-

2.8.6 Tube Arm & Stand Installation

Assemble the tube Arm with the tube stand and after the tube arm is assembled with the tube stand, assemble the thin plate to cover the screws.

For more details, please refer to the following figure.

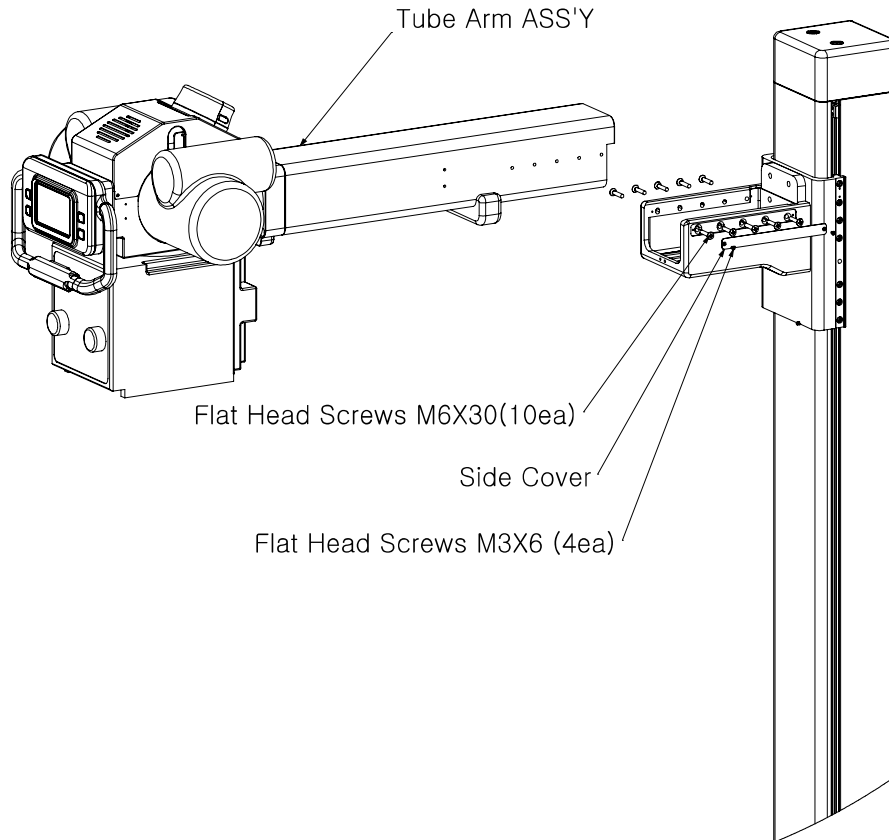

Figure 2-27. Tube Arm Installation to Tube Stand

Note

Be careful to prevent cable pinching when the tube arm is being seated on the tube stand. Verify the cable is properly connected.

2.8.7 X-Ray Tube & Collimator Installation

Assemble X-Ray tube and collimator on tube arm as the following instruction.

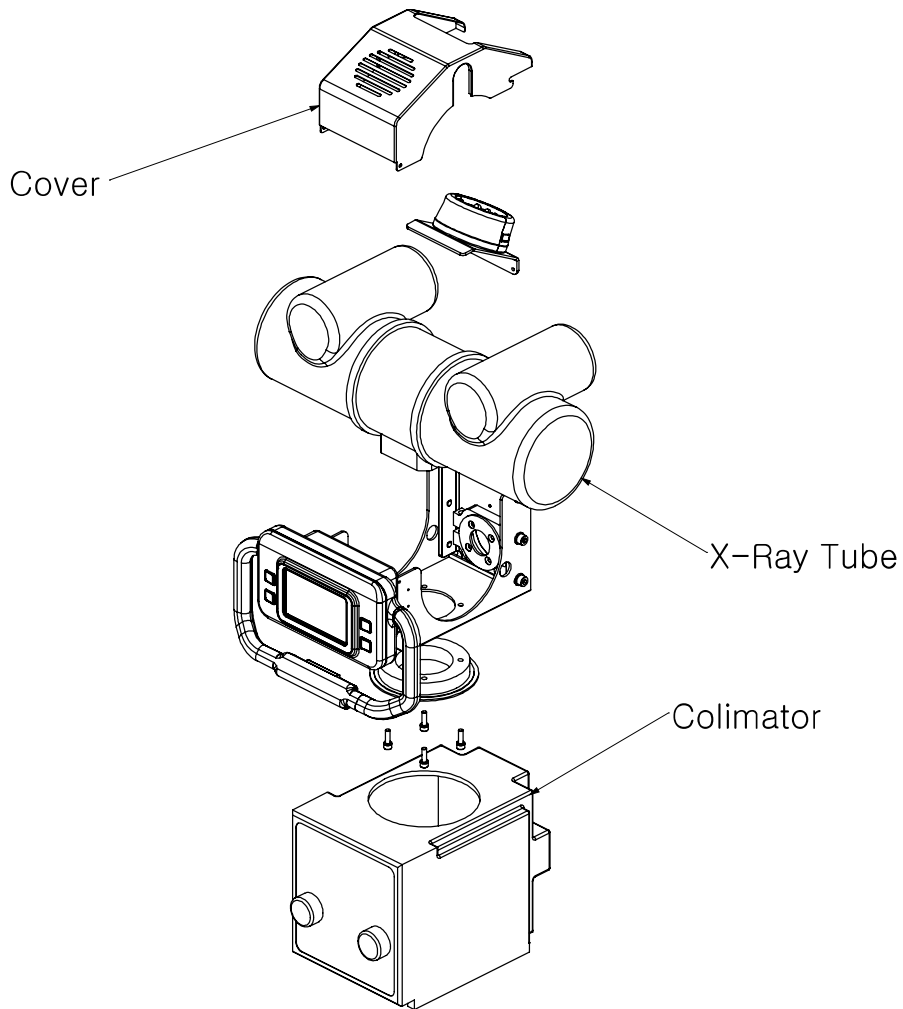

Figure 2-28. X-Ray tube and collimator Installation

Note

The correct number of spacers is required to be used when mounting the collimator on X-Ray tube. Refer to X-Ray tube and collimator instruction.

2.8.8 Spring Balancer Adjustment

The tube stand has a spring balancer each as a mechanism for moving up/down and safety. The spring balancer adjustment is originally made by manufacturer before the system is shipped out. The spring balancer may or may not need to be adjusted during the installation. Follow the procedure below if the spring balancer needs adjustment.

- 1) Open the back cover of the tube stand, to access the spring balancer, reference to the picture below.
 - 2) Adjust the spring balancer as needed, clockwise (CW) or counterclockwise (CCW). Reference to pictures below.
- Turning the spring adjuster clockwise (+) makes the balancer heavier, more tension.
 - Turning the spring adjuster counterclockwise (-) makes the balancer heavier, less tension.

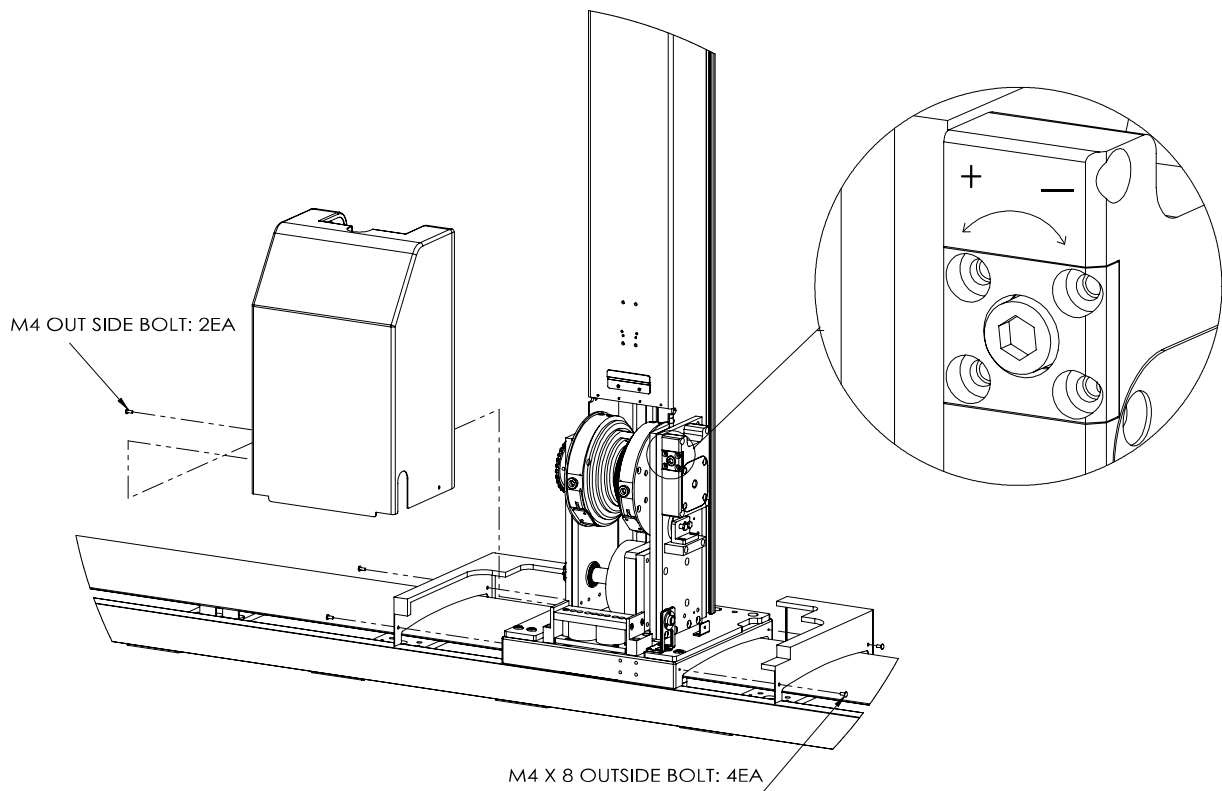

Figure 2-29. Spring balancer adjustment

Note

Make sure to use an electric drill when adjusting the spring balancer.

2.8.9 Tube Stand Level Adjustment

The straightness of the tube arm must be adjusted depending on the condition of the floor level in the room. The tube arm straightness can be adjusted using two points; The first point is underneath the tube arm and the second point on the bottom of the tube stand. These 2 adjustment points are used for straightening the tube arm and the column.

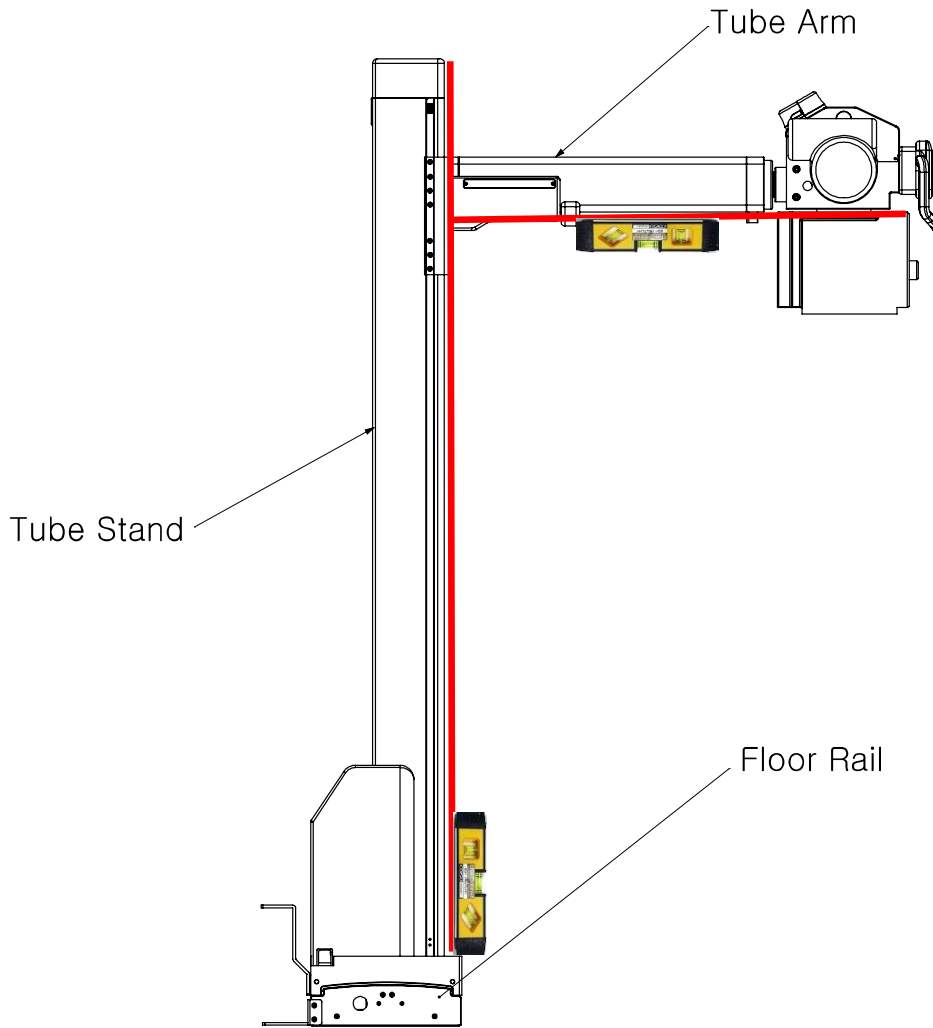

Figure 2-30. Adjust Point for Vertical Angle

Note

Make sure to use a water level for adjusting the level of the stand.

In order to adjust the straightness of the tube arm and the column,

- ① Loosen the screws on both sides and remove the cover plate.
Once the cover has been removed, adjust the leveling screws as needed.
- ② Use a water level as a conference to adjust the straightness of the tube arm.
- ③ Use a water level as a reference to adjust the straightness of the column.

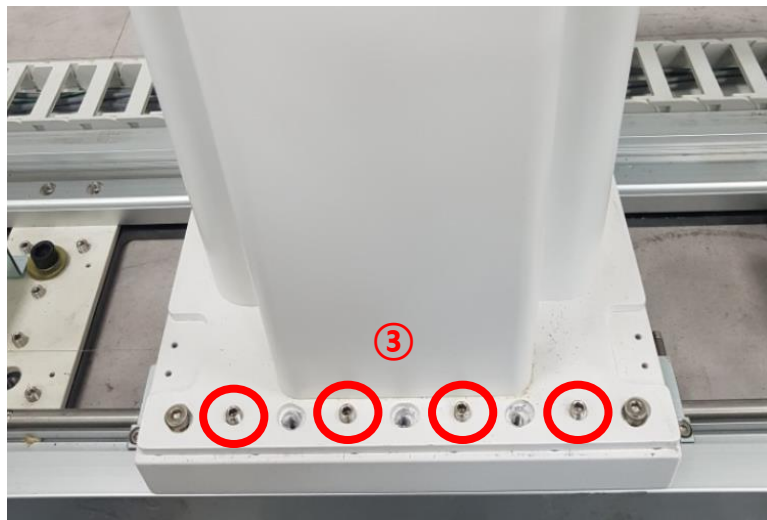
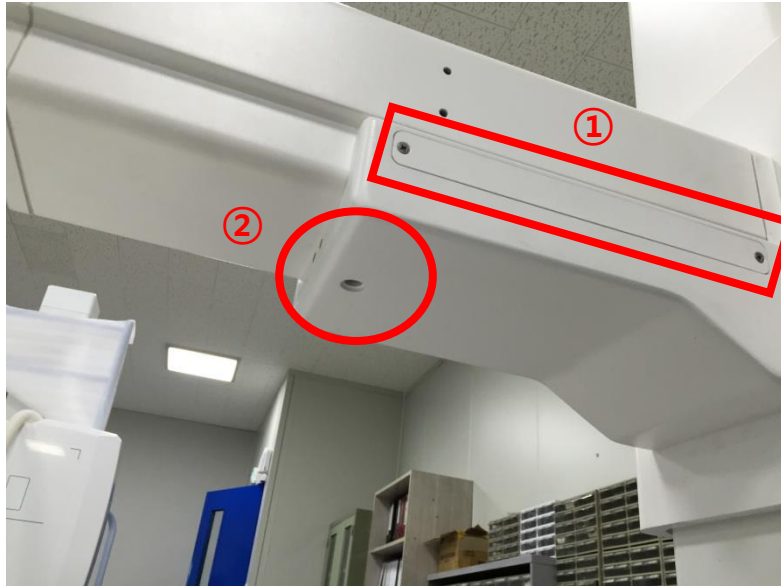

Figure 2-31. Adjust Point for Vertical Angle

2.8.10 Adjusting Tube Alignment

After the tube has been installed, the angle adjustment for the tube must be performed. Refer to the following instruction.

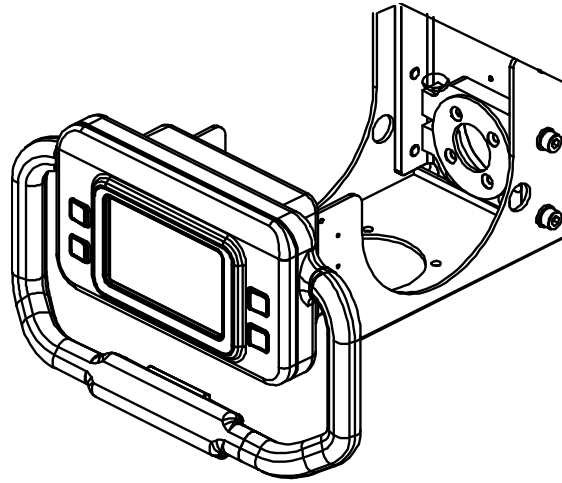

Figure 2-32. Tube Mount

- ① Unfasten the bolt "A" in the figure below and adjust angle using a water level and fasten the bolt "A" back again to fix the desired angle.

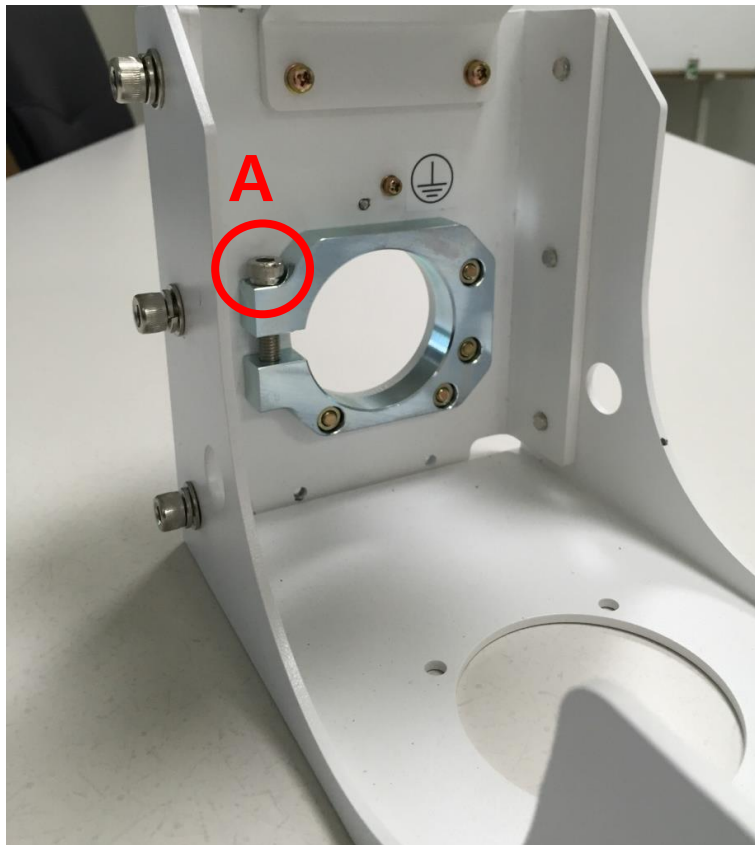

Figure 2-33. Tube Alignment Adjustment Point

- ② Loosen all the screws 1, 2, and 3. Adjust the angle as needed using a water level and fasten the bolts again to fix the desired angle.

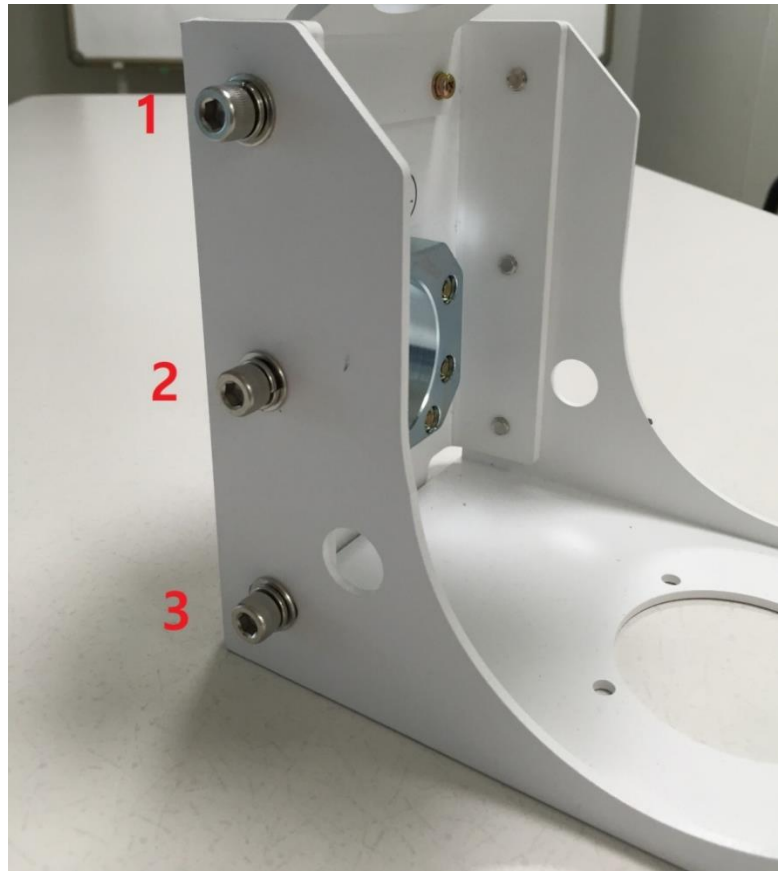

Figure 2-34. Tube Alignment Adjustment Point

2.8.11 Adjusting Control Panel Level

It is available to adjust the level of the control panel by loosening and tightening the four screws for attaching the control panel to the tube hanger.

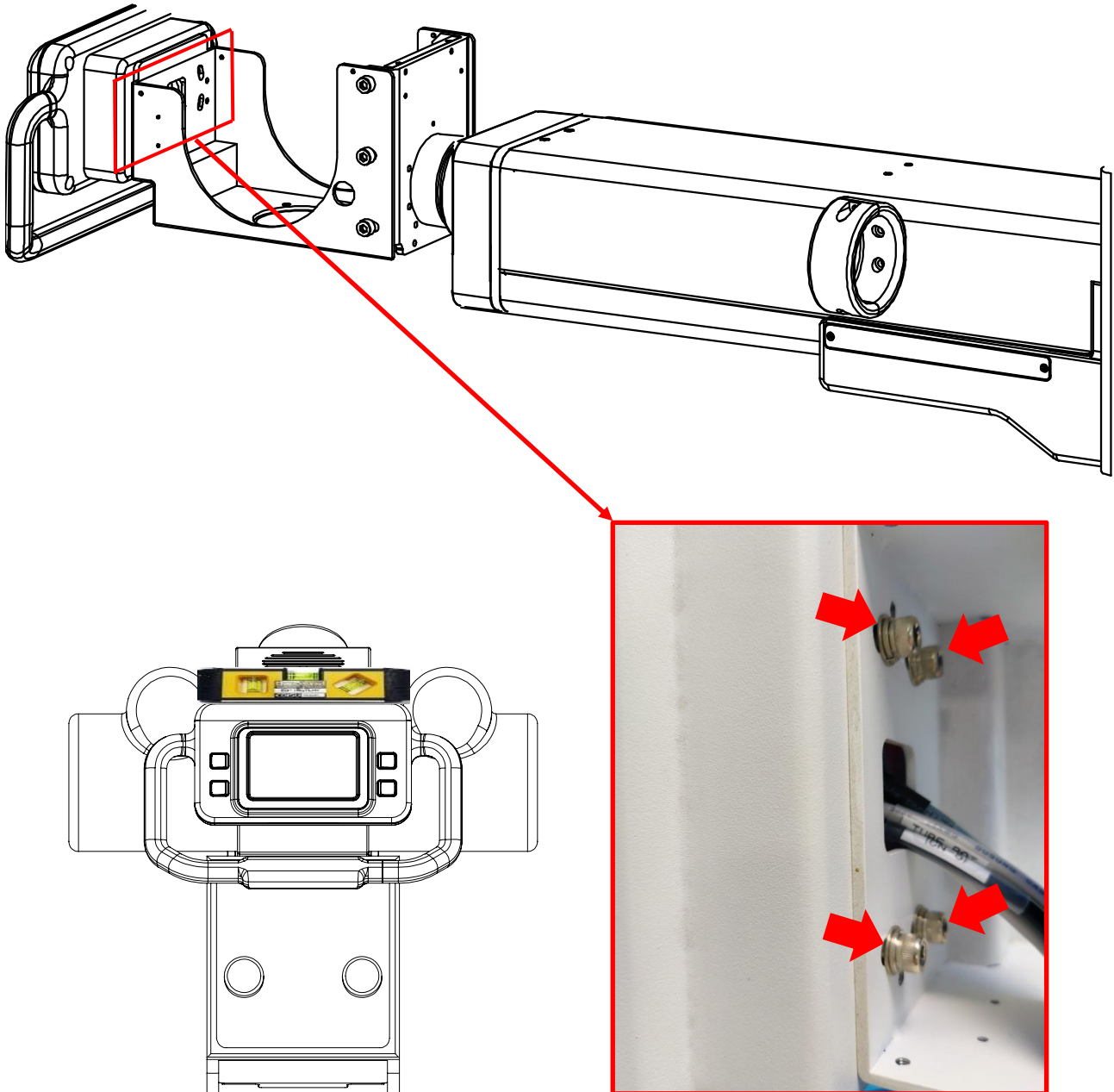

Figure 2-35. Control Panel Level Adjustment

⚠ Caution

Make sure to use a water level and fully tighten the screws so that the control panel doesn't get loosened when using the control panel for manual movements.

2.8.12 Adjusting Tube Stand Magnet Brake

There should be 0.5mm of gap between the magnet brake and block, and when the magnet brake is attached, then tighten the screws.

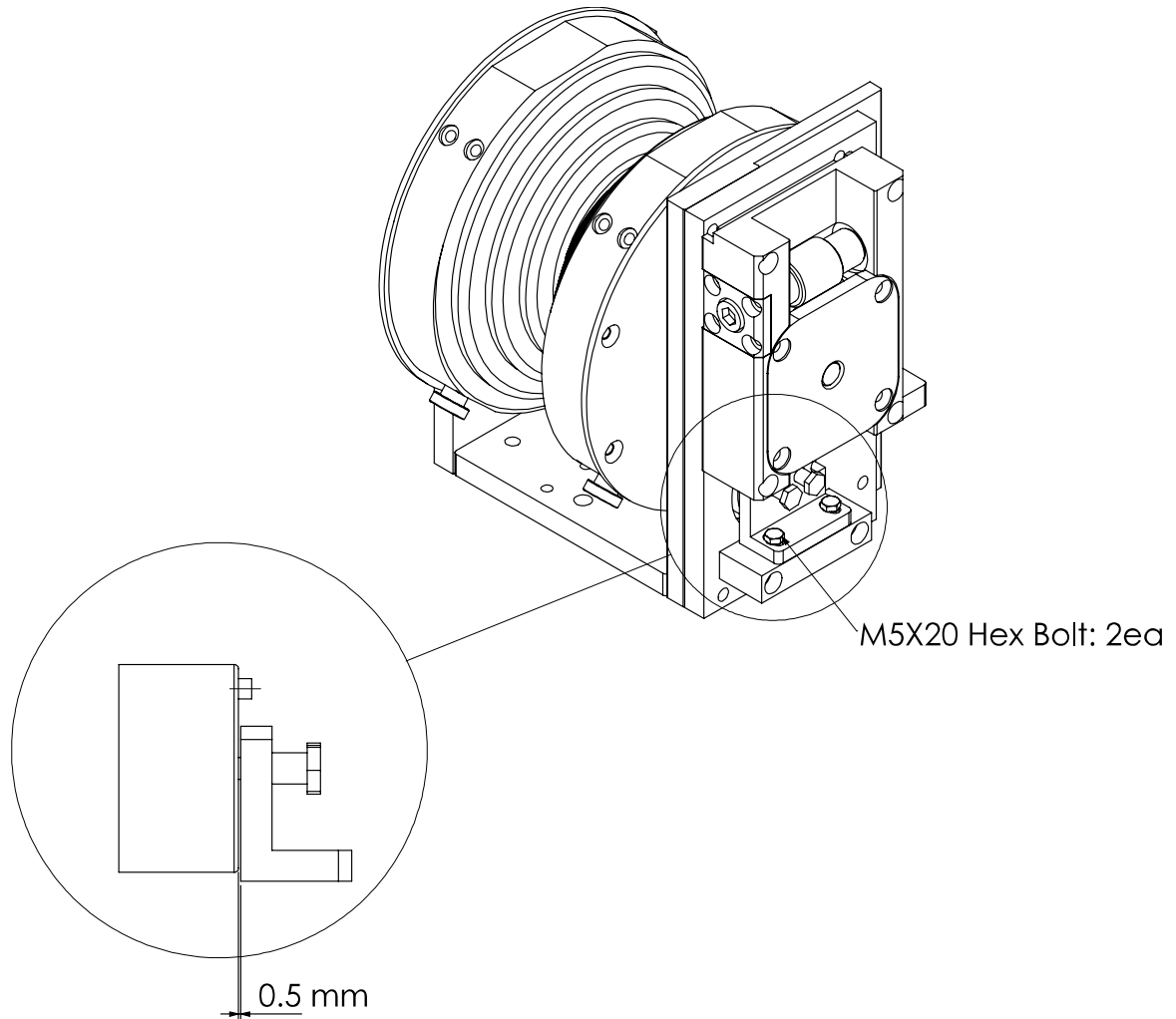

Figure 2-36. Magnet brake adjustment

2.9 Bucky Stand Installation

The bucky stand should be located at a proper location to be perfectly aligned with the tube stand laterally. Once the location is set, fix the stand with anchor bolts. There are four holes on the base plate to fix the stand with anchor bolts as described in the following figure.

It is required to open the front cover of the bucky stand to find two anchor bolts in the frontside.

Lastly, level the stand with the six set screws referring to the following figure for the hole locations.

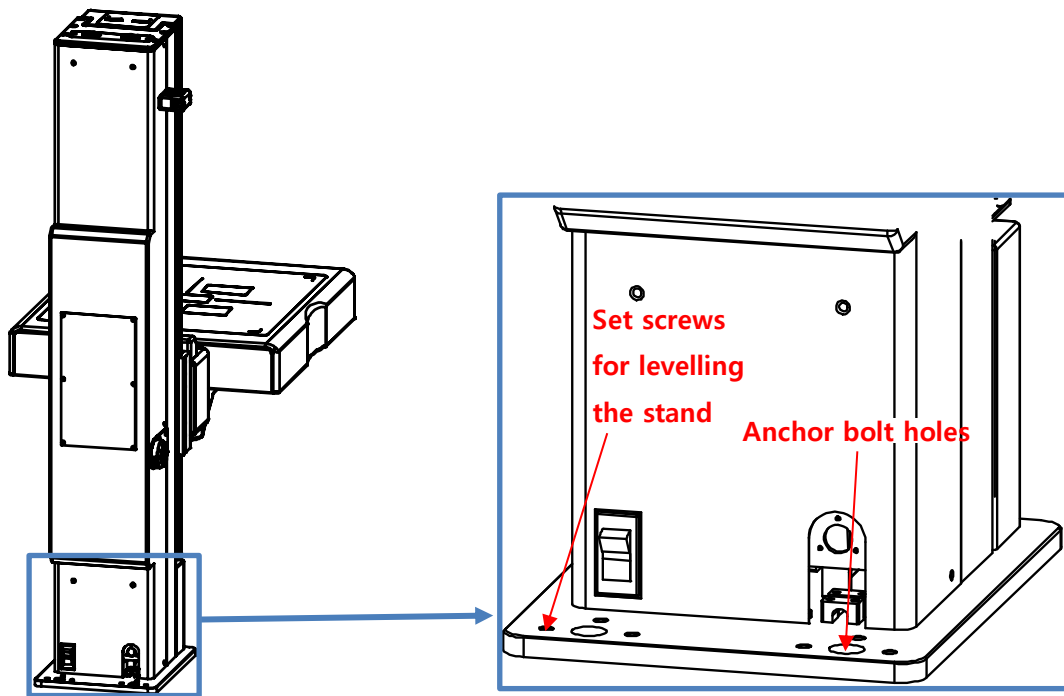

Figure 2-37. Anchor Bolt Hole Locations (Backside)

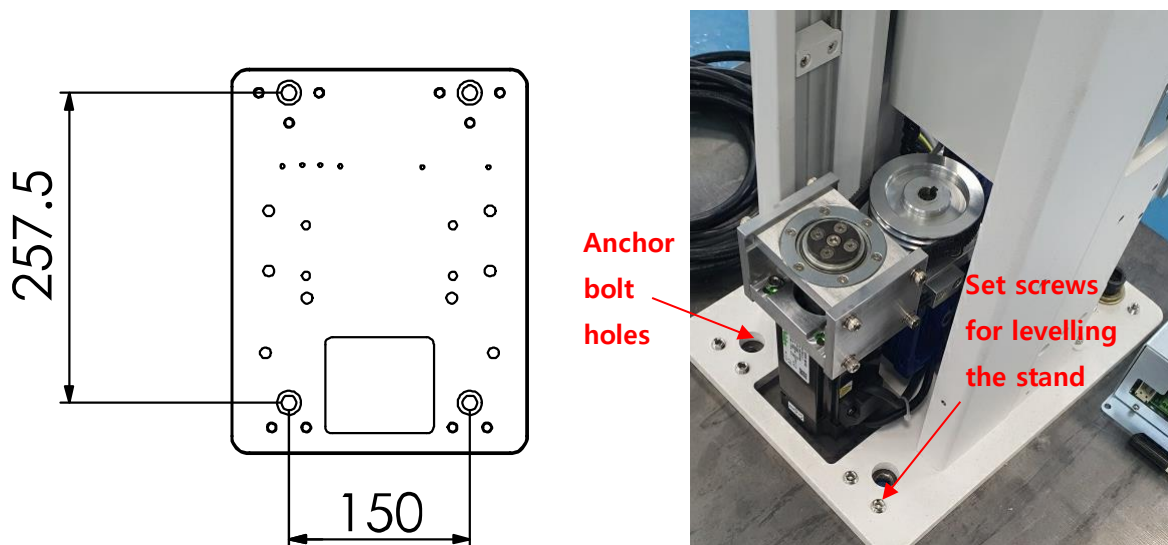

Figure 2-38. Drill Template & Anchor Bolt Hole Locations Frontside

2.9.1 Converting to Right-Hand Load

The bucky stand provided is basically to be placed in the left side. In order to convert the bucky stand be place in the right side, refer to the following steps in order.

- 1) Remove the front cover from the bucky rotation assembly.

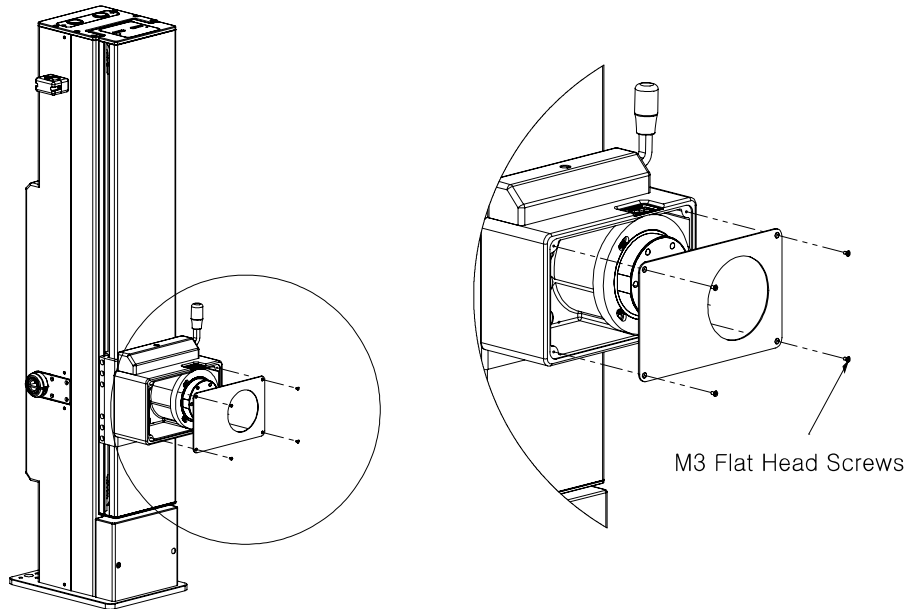

Figure 2-39. Removing front cover

- 2) Unscrew the three M4 wrench screws in the following figure and remove the goniometer.

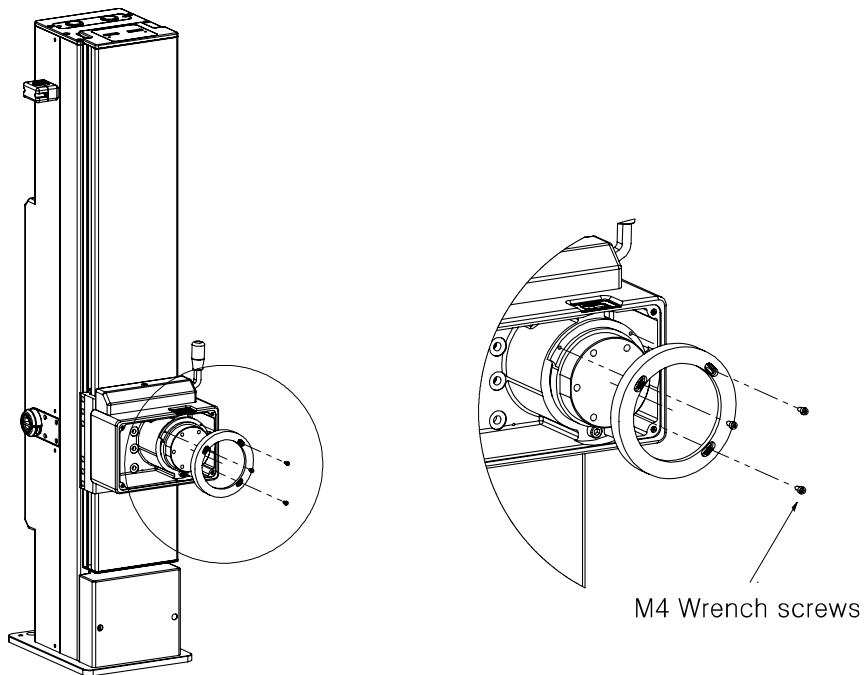

Figure 2-40. Removing goniometer

3) Remove the M8 wrench bolt which is the angle limit of the bucky rotation assembly.

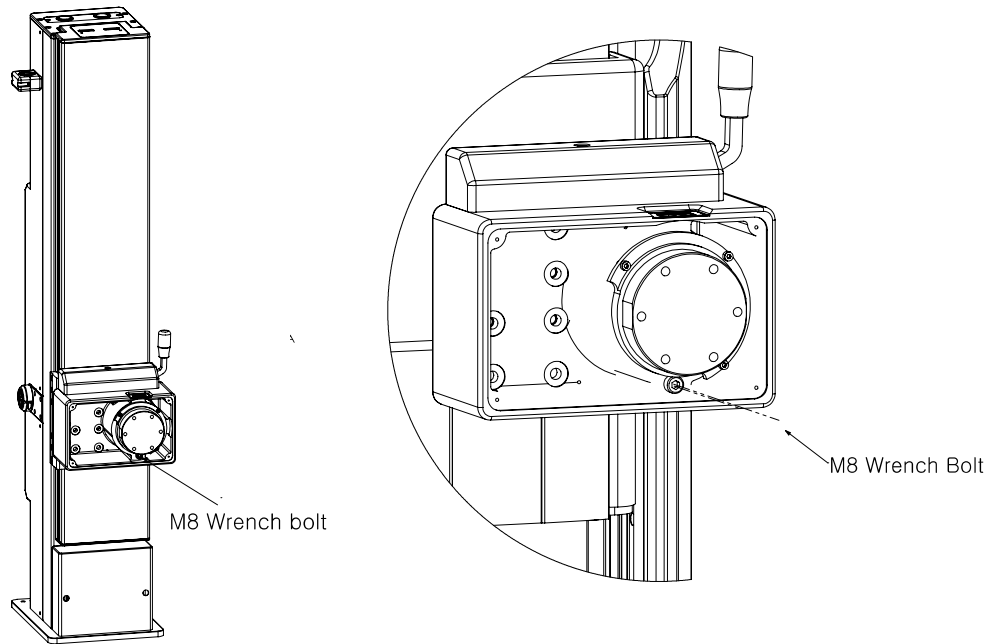

Figure 2-41. Removing M8 wrench bolt

4) The figure below shows where the hole location of the M8 wrench bolt should be when using the right-hand load. Move the hole location of the M8 wrench bolt and fasten it.

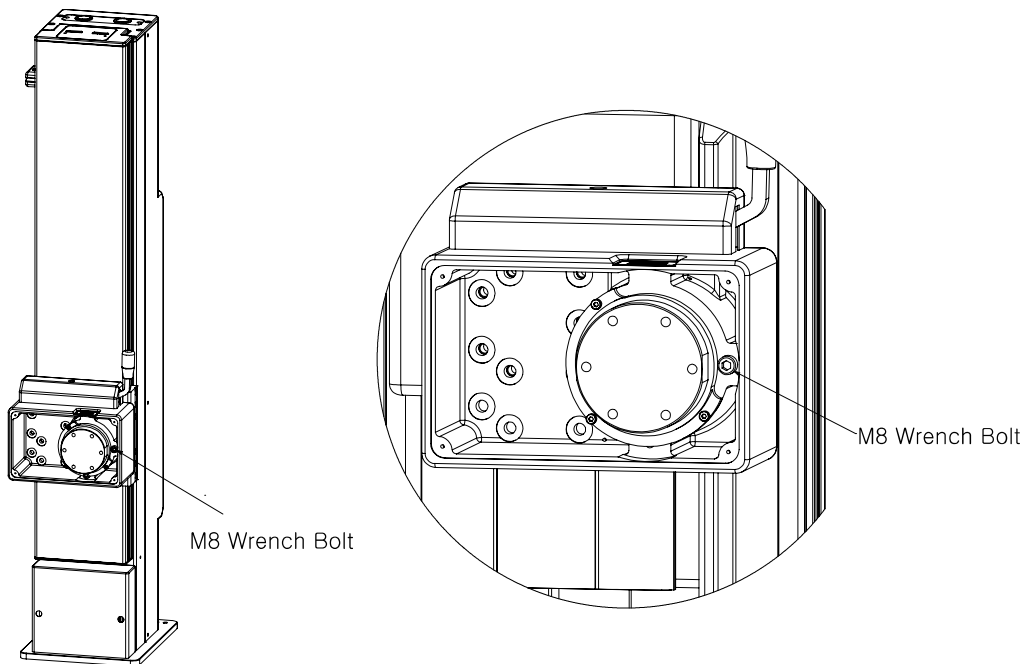

Figure 2-42. Moving hole location

5) Reassemble the goniometer and front cover.

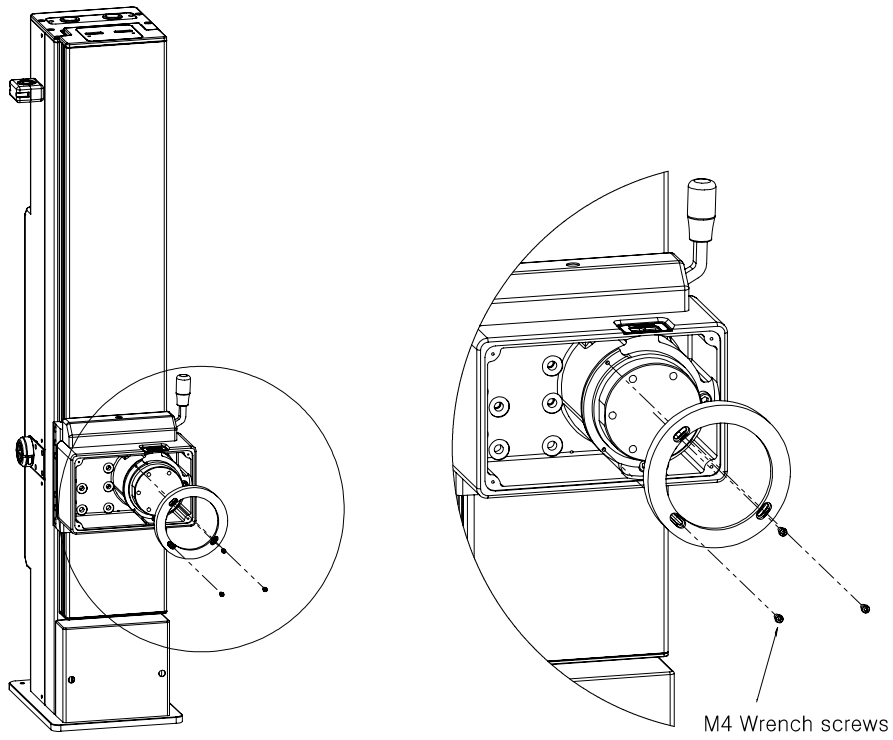

Figure 2-43. Reassembling goniometer & front cover

6) Prepare a right-hand load bucky.

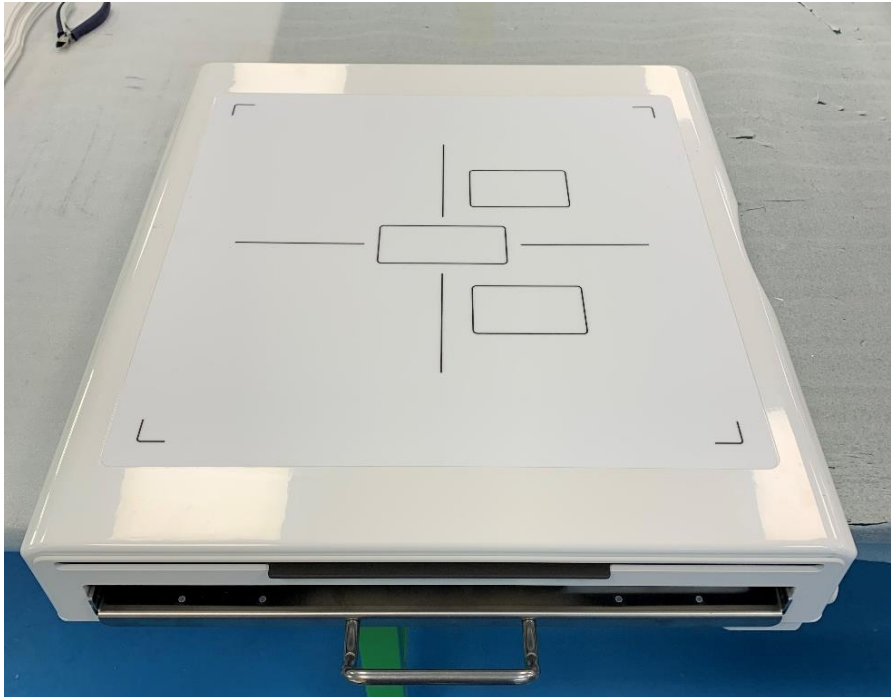

Figure 2-44. Right-hand load bucky

- 7) The grid frame should be removed to open the bucky front cover. Push and up the grid frame as shown below.

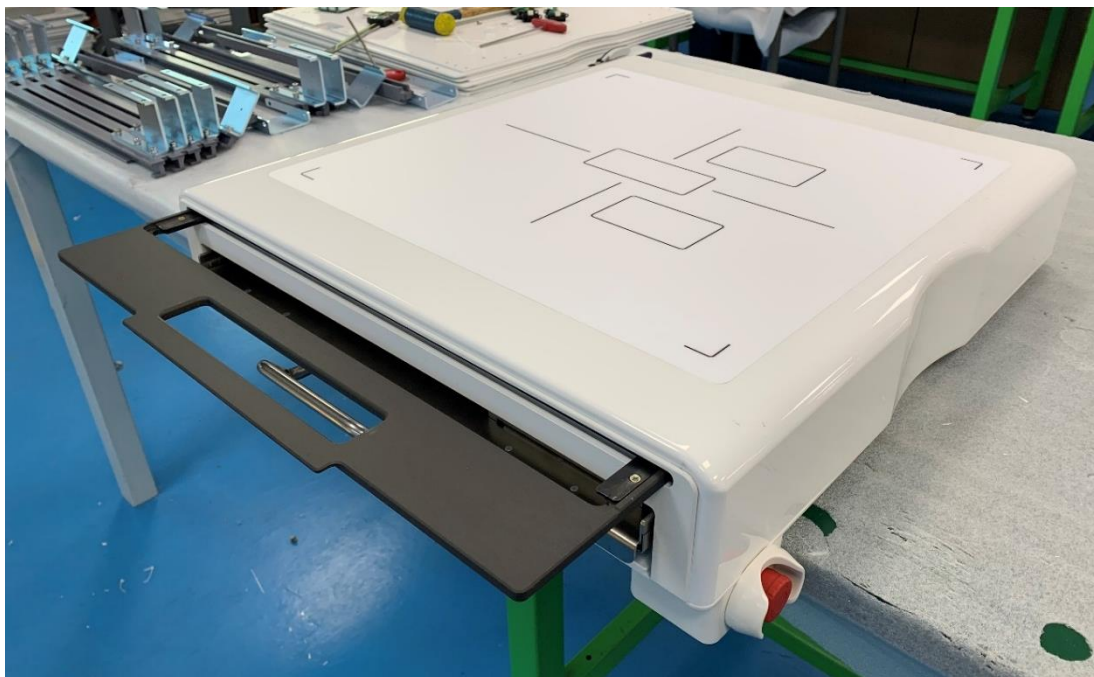

Figure 2-45. Removing grid frame

8) Loosen and remove all screws in the picture to open the bucky front cover.

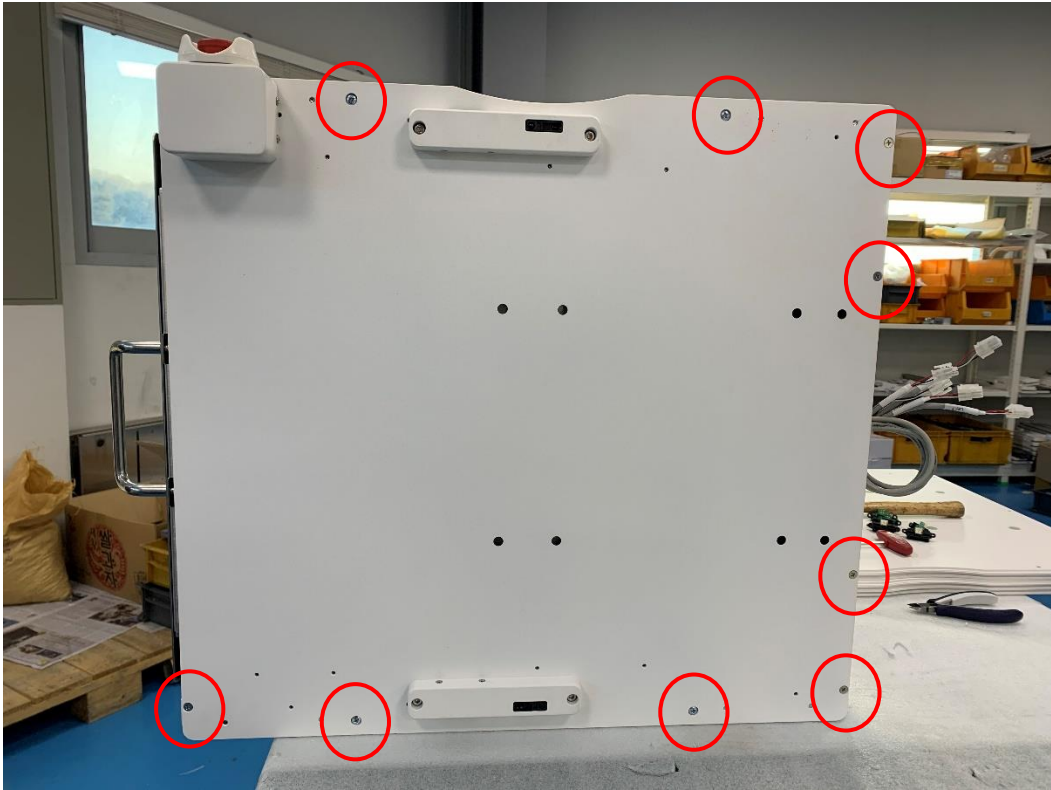

Figure 2-46. Removing screws

9) Pull out the cassette tray a little as shown in the picture.



Figure 2-47. Pulling out cassette tray

10) Remove the bucky front cover.



Figure 2-48. Removing bucky front cover

11) Assemble the bucky enclosure to the bucky bracket with the holes on the bucky base as follows and put all the parts back on.

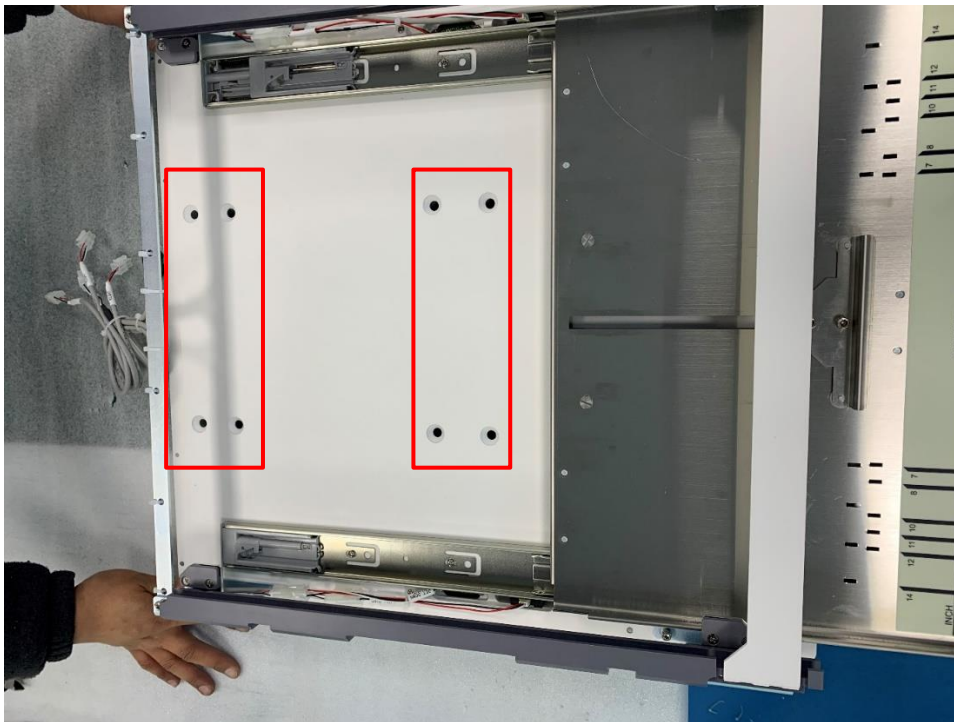

Figure 2-49. Bucky mounting holes

2.10 Bucky Enclosure

There are two types of the bucky enclosure, DR and Cassette Tray, and the components of each bucky enclosure are explained in the following figures.

2.10.1 Bucky Structure (DR Panel Type)

Mount the bucky base on the bucky stand first and then assemble the parts in the bucky referring to the following figure.

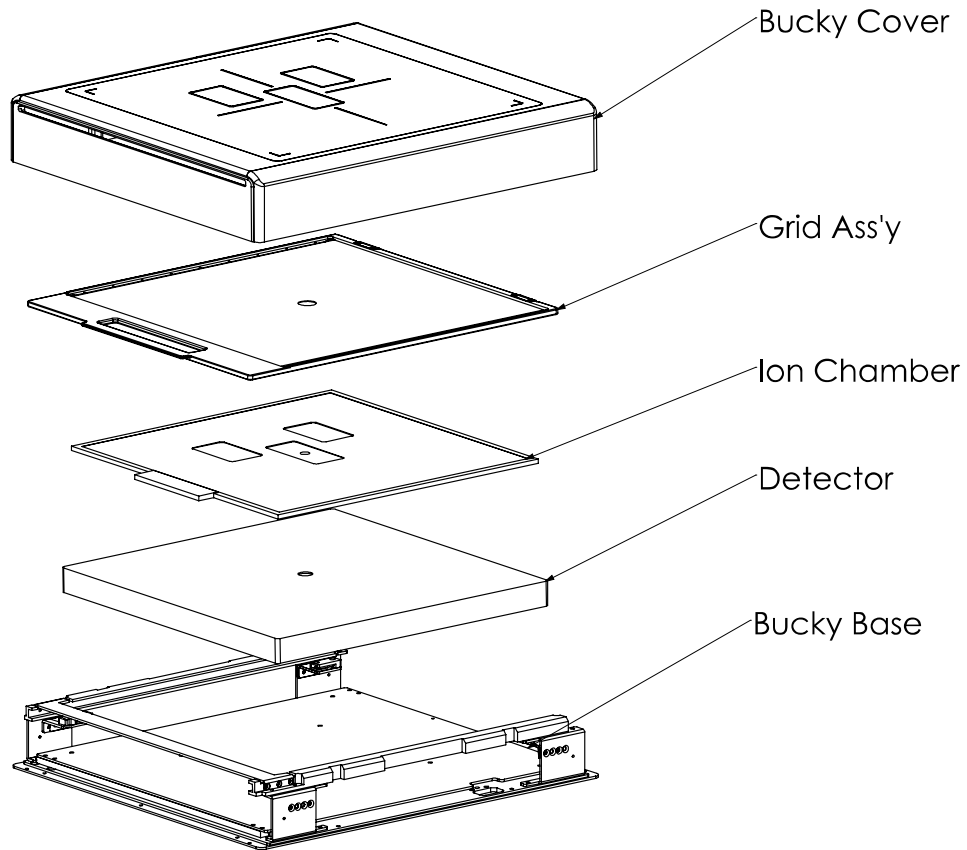

Figure 2-50. Bucky for DR Panel

2.10.2 Bucky Structure (Cassette Type)

Mount the bucky base on the bucky stand first and then assemble the parts in the bucky referring to the following figure.

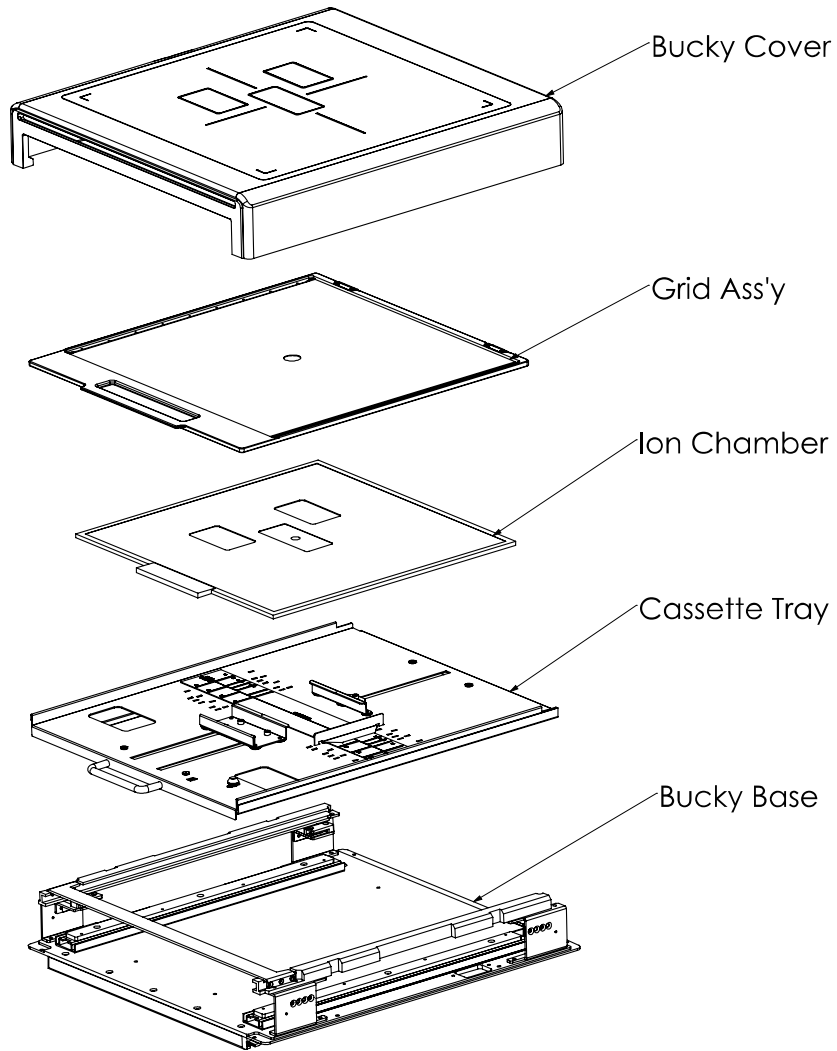

Figure 2-51. Cassette Bucky

2.11 Connecting Cables

The cable connections need to be done properly to ensure the system to work correctly. Refer to the following information for correct connection.

2.11.1 Tube Arm & Tube Stand Cable Connections

Connect the cables from the tube arm and control panel of the tube stand.

When connecting the cables, the labelling of the cables must be matched each other.

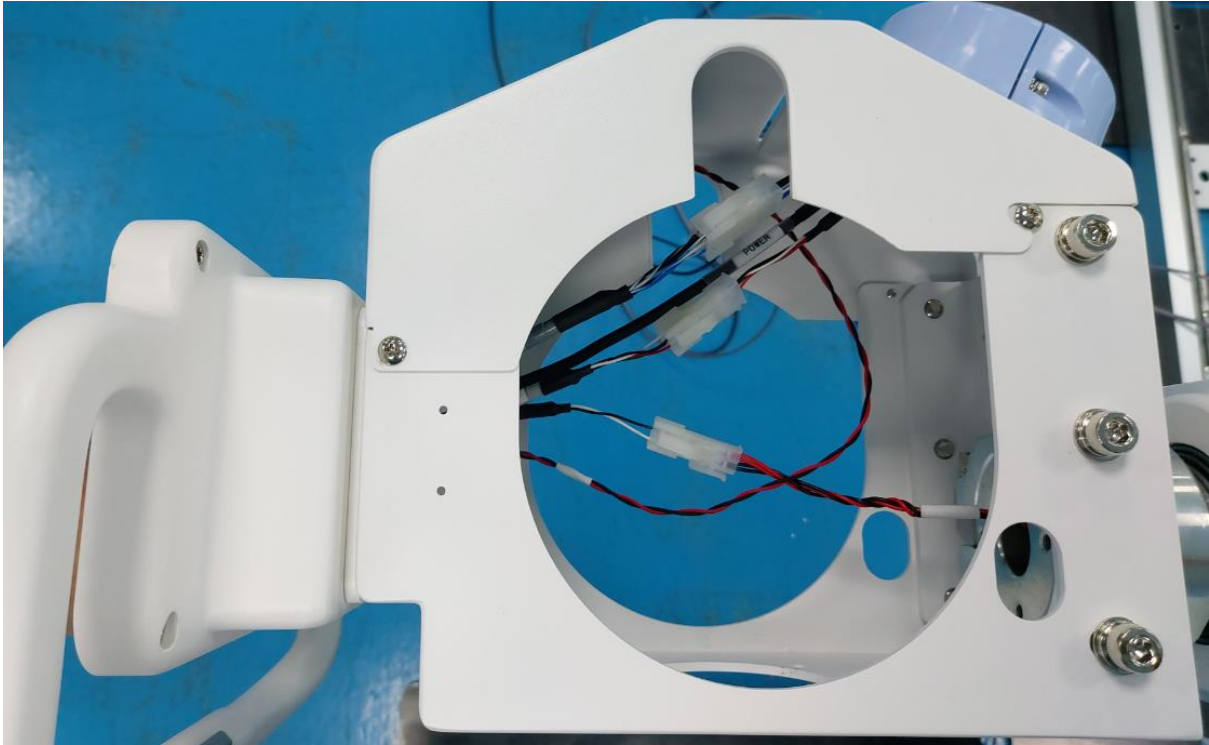

Figure 2-52. Tube Arm & Tube Stand Connections

- OP CAN: The CAN connection of the control panel and the tube stand.
- POWER: The connection for the Input power
- U/D PMB: The magnet brake for the vertical movement of the tube arm.
- L/R EMB: The magnet brake for the longitudinal movement of the tube stand.
- TUBE ROT: The magnet brake for the tube arm rotation.

2.11.2 Tube Stand & Rail Cable Connections

When connecting the cables, the labelling of the cables must be matched each other.

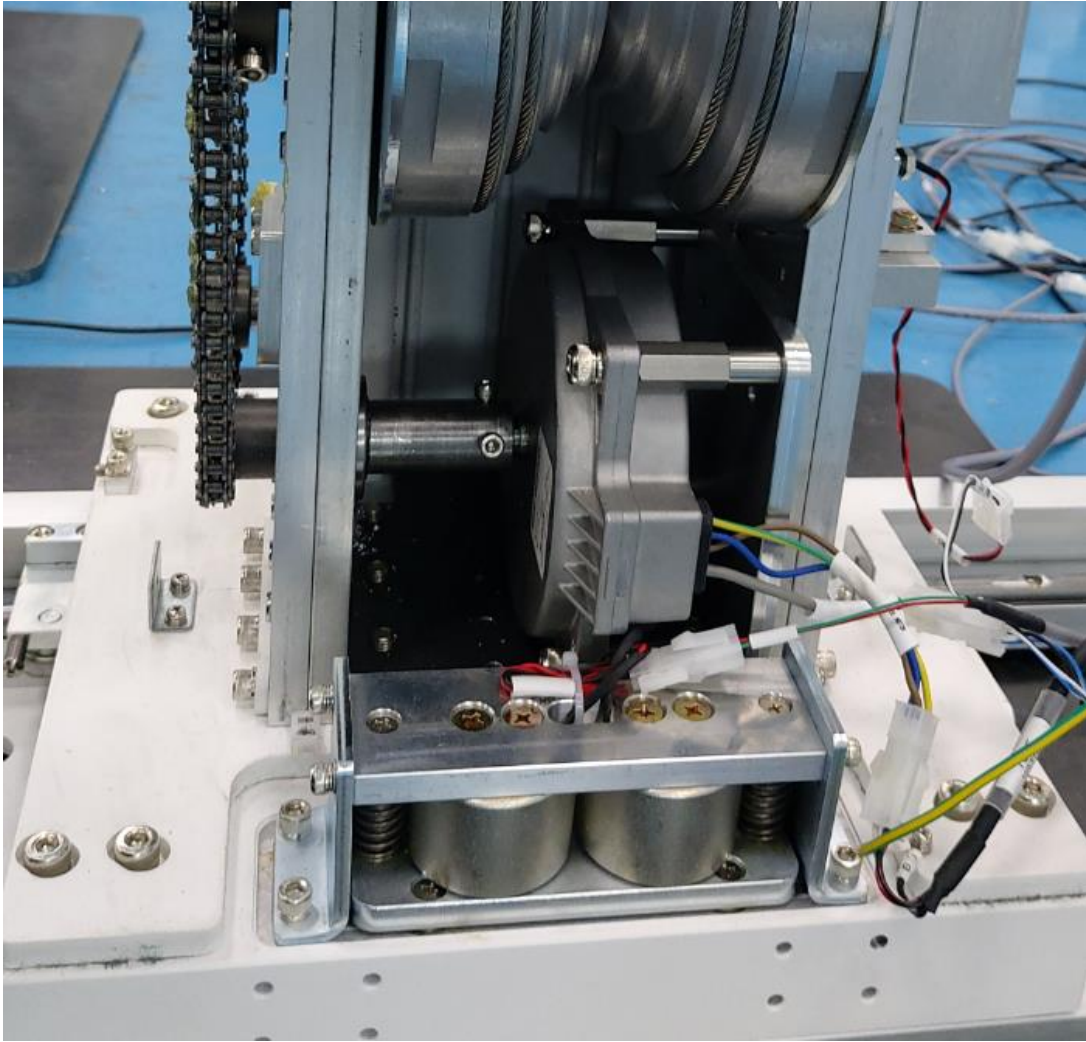

Figure 2-53. Tube Stand & Rail Connections

- Tube Motor: The connection for the Input power of the tube stand motor.
- Tube Encoder: The connection for tube stand encoder.
- L/R EMB: The magnet brake for the longitudinal movement of the tube stand.
- U/D PMB: The magnet brake for the vertical movement of the tube arm.

2.11.3 Connecting Foot Switch, CAN, and Power Cables

Connect the cables referring to the following figure.

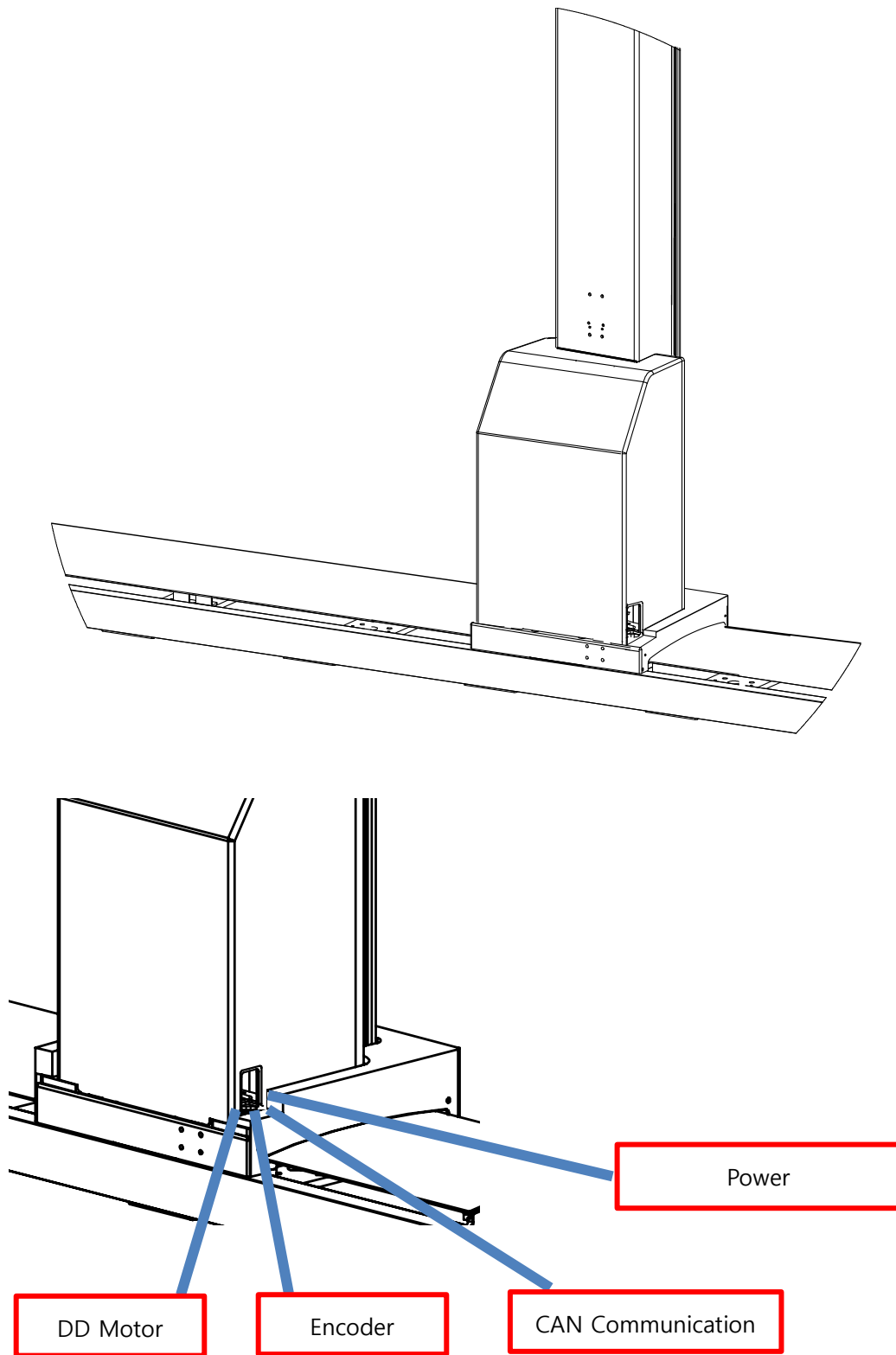

Figure 2-54. Tube Stand Connections

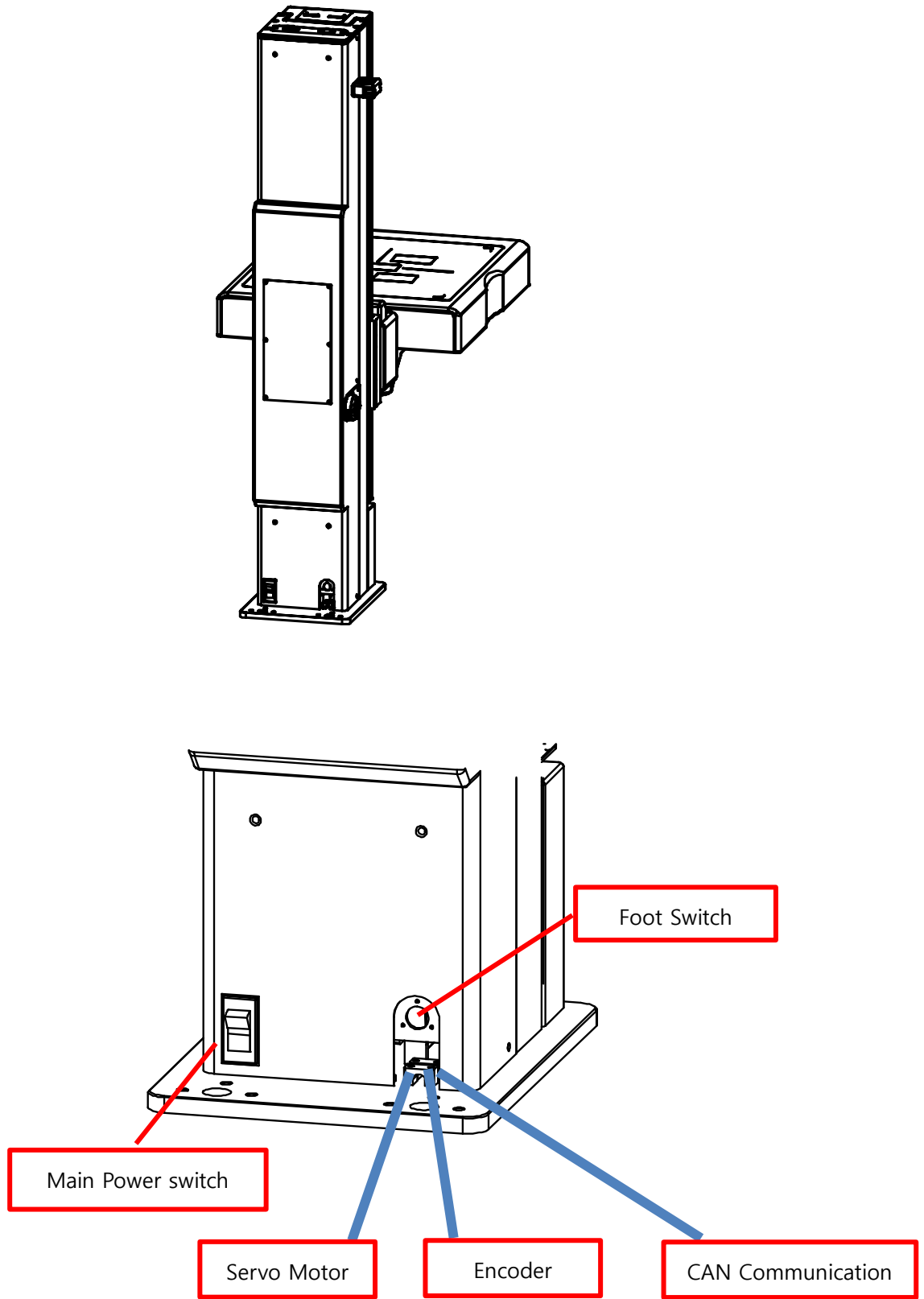

Figure 2-55. Bucky Stand Connections

2.11.4 CAN Connections

The CAN communication is used as a method for the communication in the system. Please refer the following information for the connection of the stands.

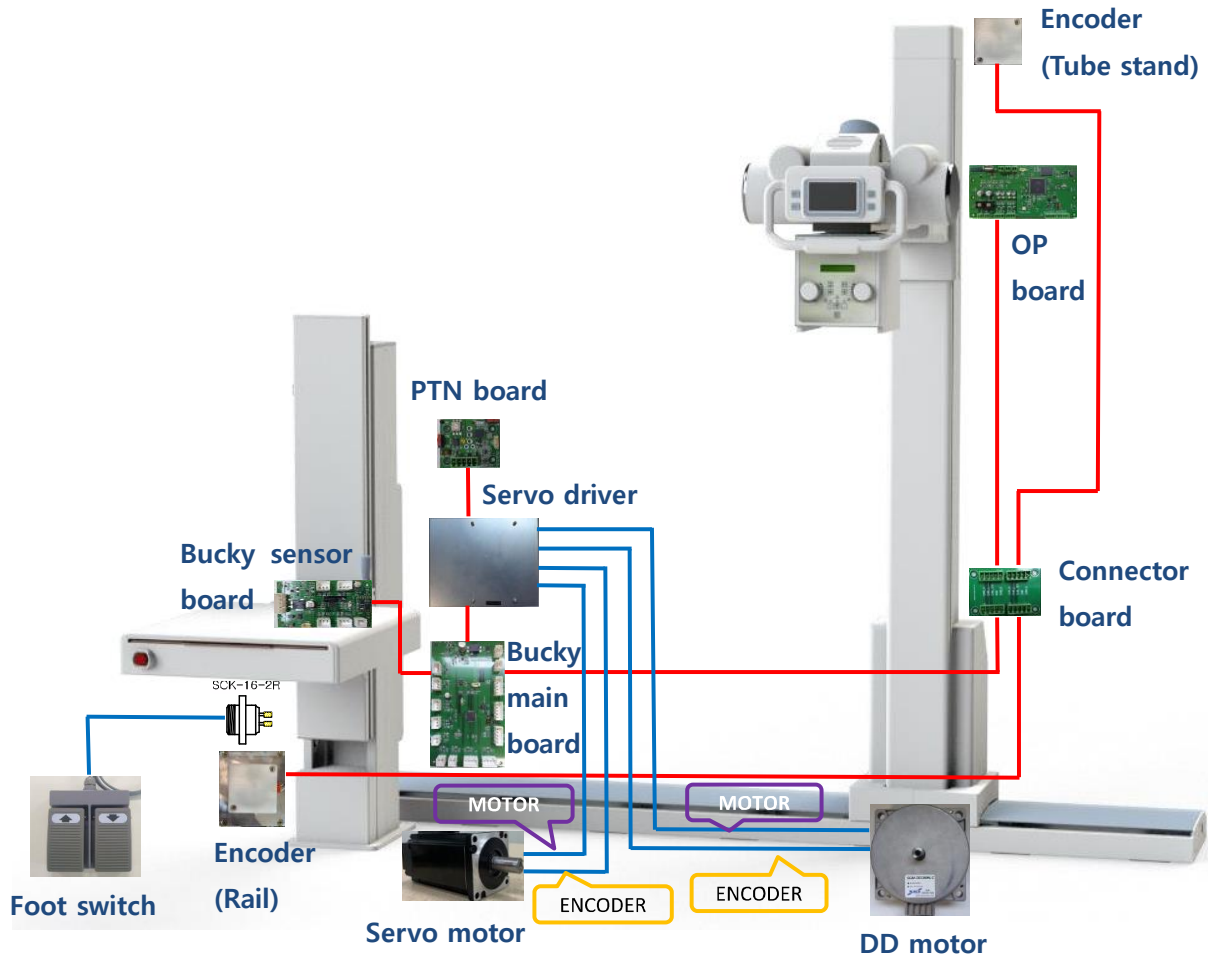
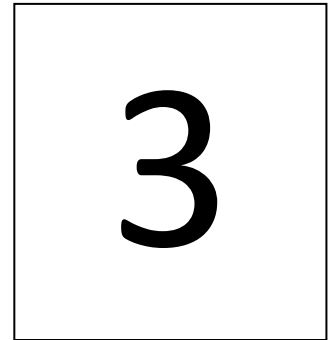

Figure 2-56. CAN Connections

Operation



3.1 Introduction

This chapter is about the operation of SST-3100. It is required to learn about the travel range of all the movements of the entire system before operating the system.

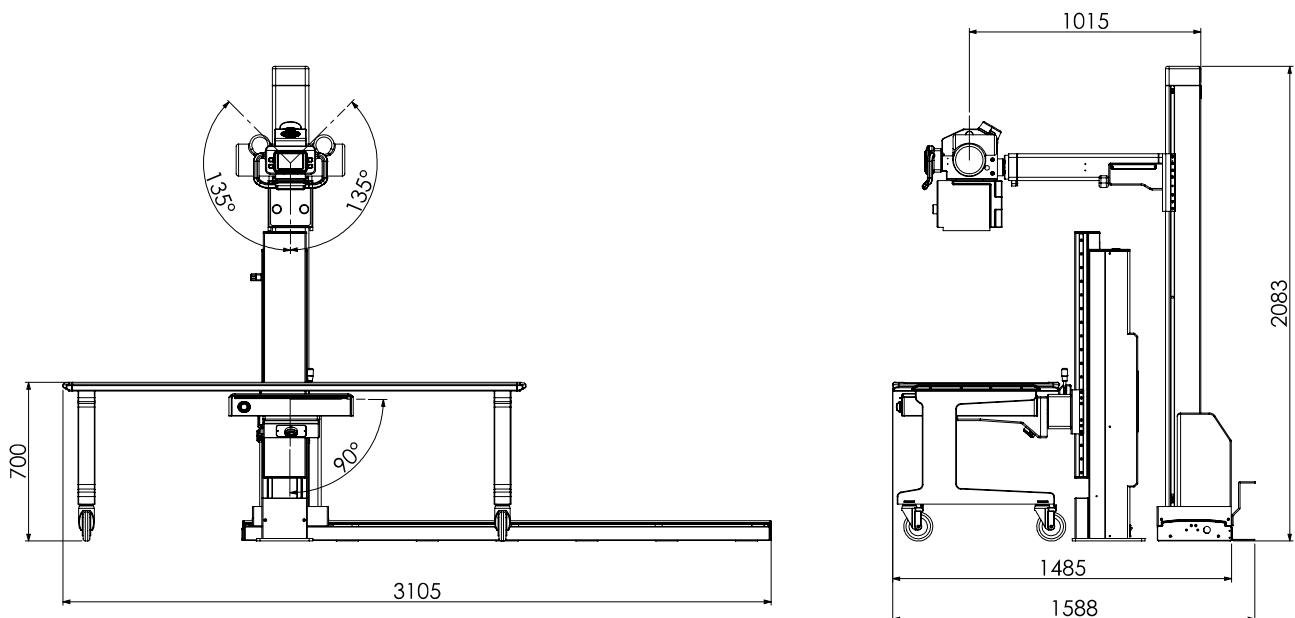

Figure 3-1. System Operating Range

3.2 Power On / Off

To supply the power to the system, turn the power ON by pressing the power switch located on the table. (Refer to "2.13.3 Connecting Power IN/OUT")

Check all cable connection between the stands and table before turning ON the power.

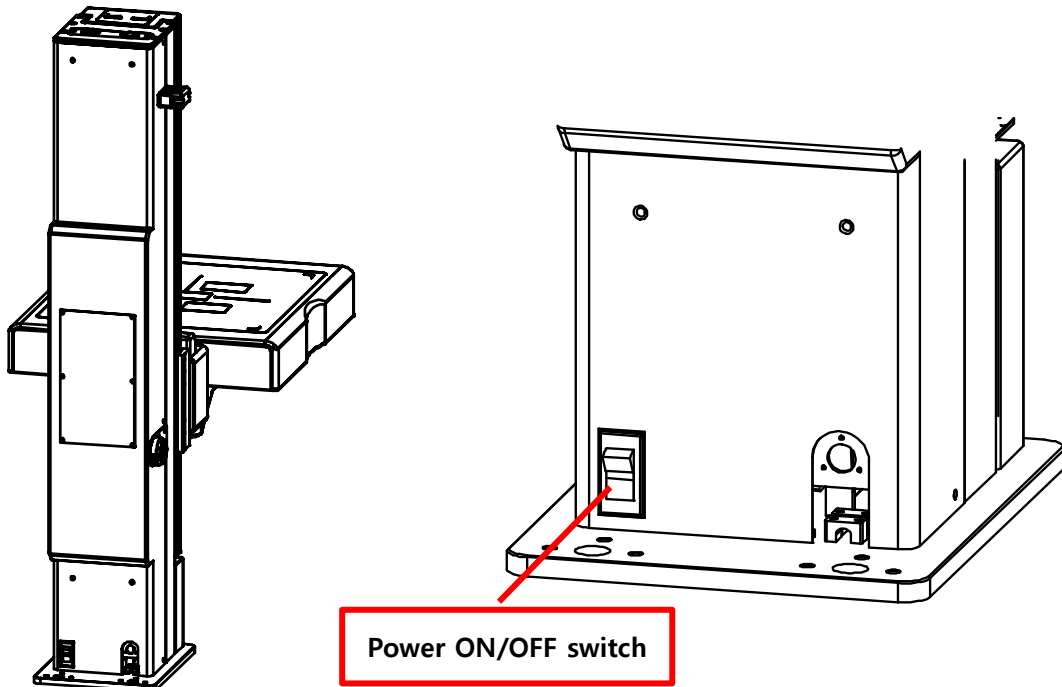

Figure 3-2. Power ON/OFF Switch



Caution

Before powering on the system, please check that there is nothing on the detector surface or on the tube stand rail cover.

3.3 System Operation

It is important to learn how to operate each component of the system.

There are anti-collision sensors to prevent collisions between the stands and user during operation.

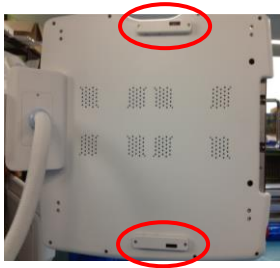

1. Bucky sensor:

This sensor is to avoid any collision between the tube stand and the bucky stand when they move up/down.



2. Top column sensor:

This sensor is to avoid any collision between the tube stand and the bucky stand when they move up/down.

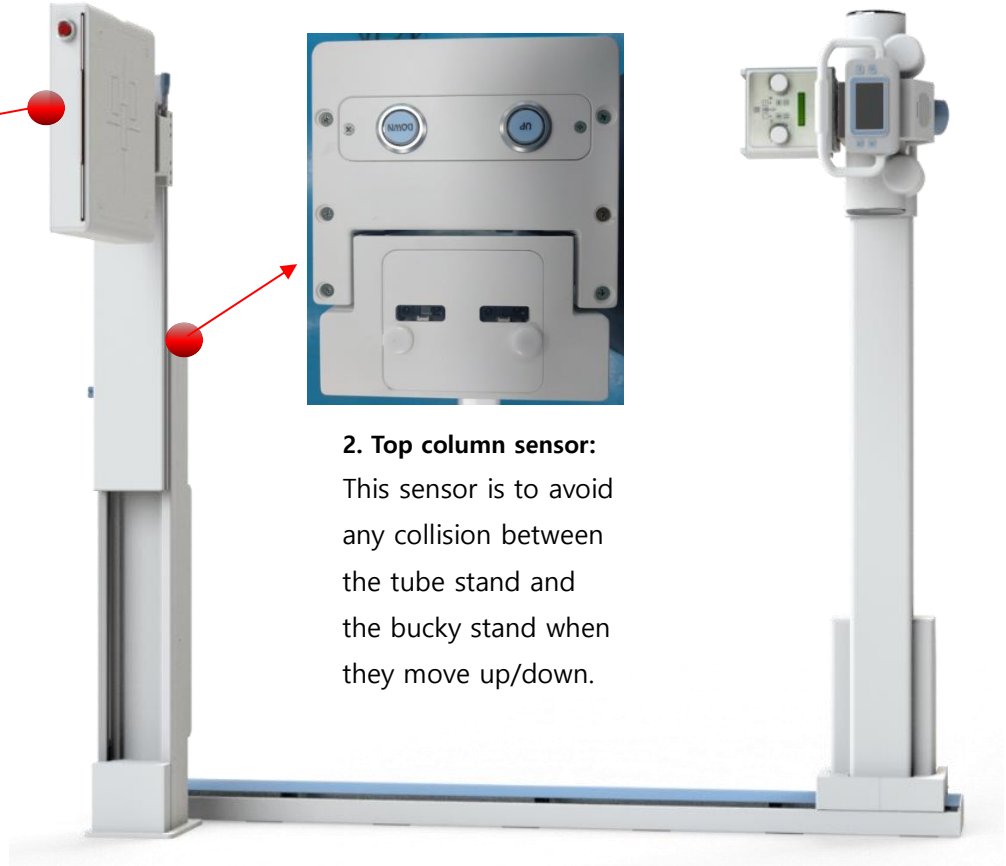

Figure 3-3. Anti-collision sensors

3.3.1 Operating Bucky Stand

It is available to move the bucky up or down either by the up/down switch located on back side of the column or connecting the foot switch to the bucky stand.



Figure 3-4. Up/Down Switch

To rotate detector, press the lever and rotate the detector at your desired position manually.

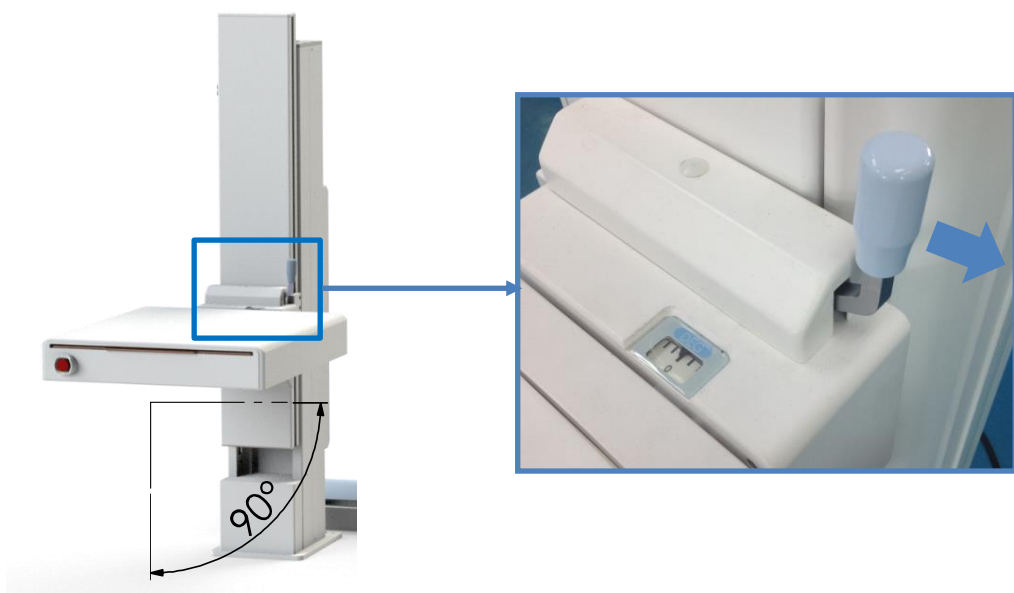

Figure 3-5. Detector Rotation

3.3.1.1 Bucky Stand Movements

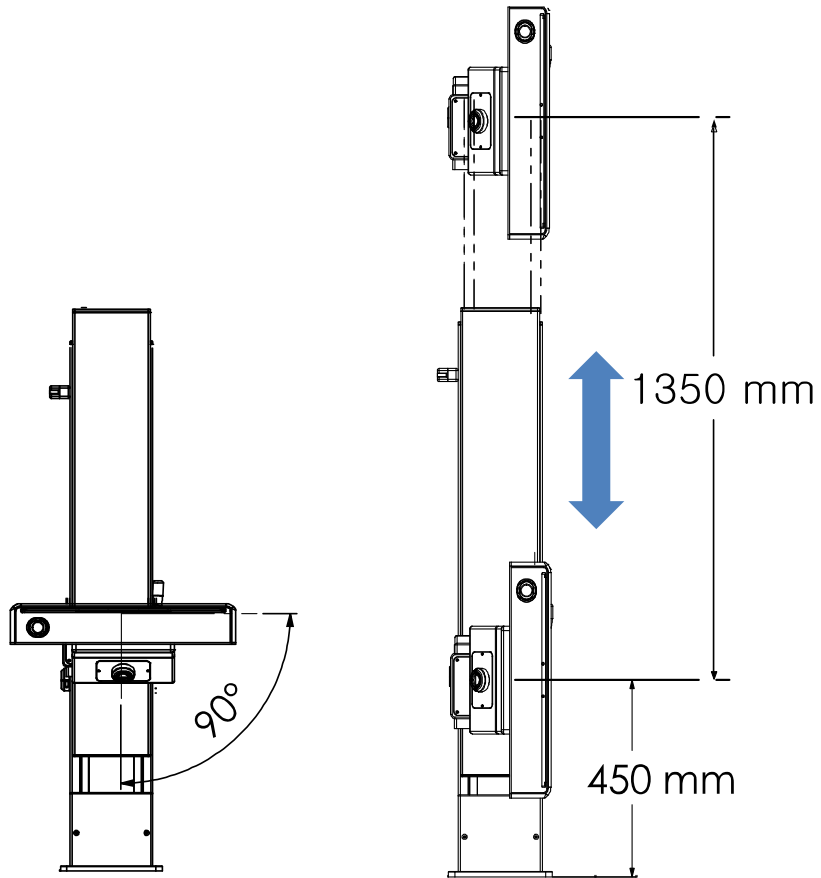

Figure 3-6. Bucky Stand Movements

3.3.2 Operating Tube Stand

The following figure explains about the major components for operating the tube stand.

Control Panel:

5" LCD display to control the movements of the tube stand.





Figure 3-7. Operation of Tube stand

3.3.2.1 Control Panel

It is mandatory to learn how to use the control panel properly with different buttons. The control panel comprises the control buttons with their corresponding symbols.



Figure 3-8. Control Panel

Control Component	Graphic	Description
UP/DOWN		Allows to manually move the tube head up/down manually while holding this button.
Rail Slide		Allows to manually move the tube stand to left or right while holding this button.
Tube Rotation		Allows to manually rotate the tube head to CW or CCW direction while holding this button.
All-Free button	N/A	Pressing and holding the button on the handle bar with a hand allows to move the tube up/down and left/right.

3.3.2.2 Tube Stand Movements

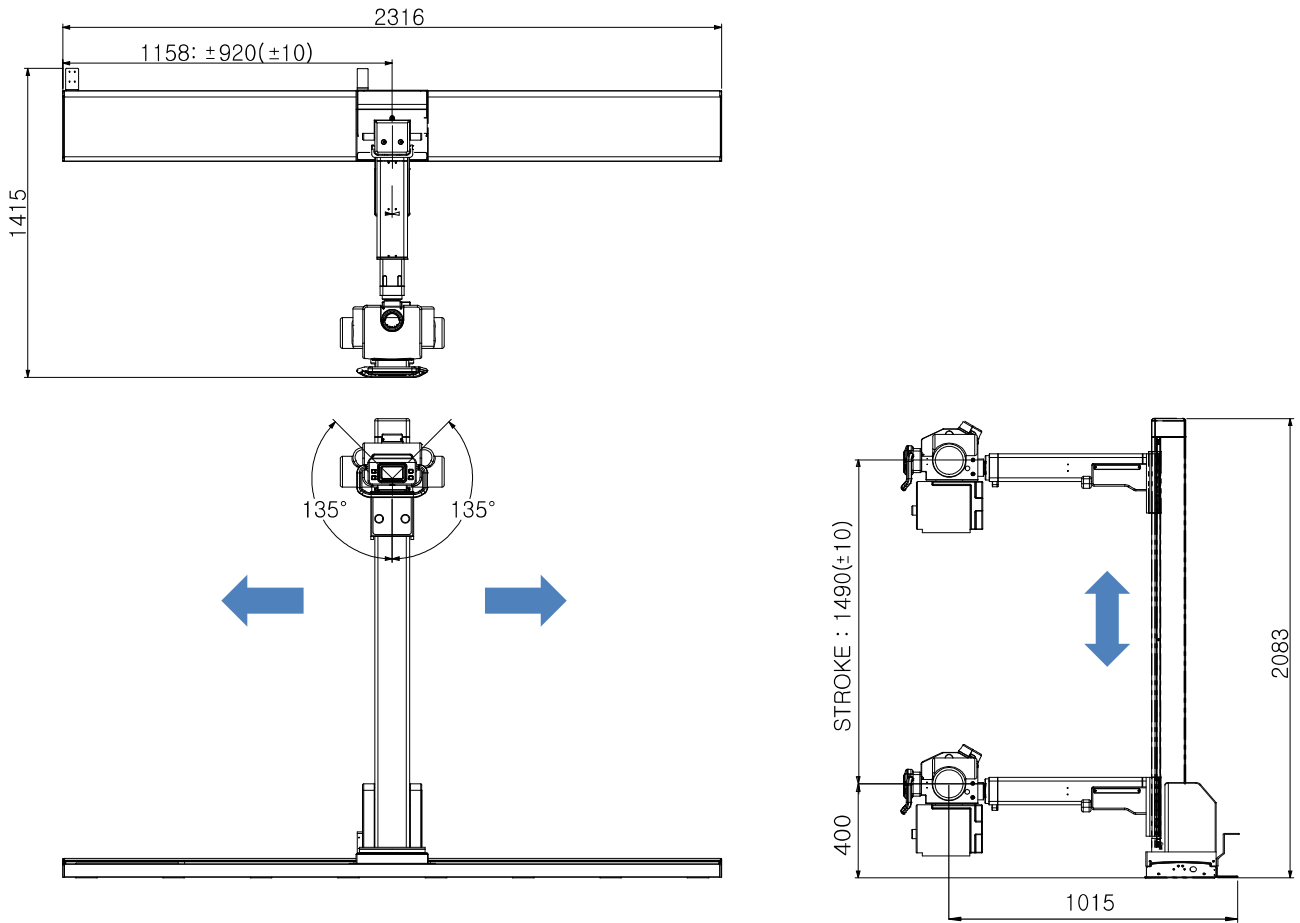

Figure 3-9. Tube stand movements



Warning

For patient's safety, be cautious to prevent collision when the patient is on the table and moving the tube down manually.

3.3.2.3 Information of Display

When turning the power on, the screen in the following figure will be shown. The screen basically shows two kinds of information which are "SID" and "DEG". The "SID" shows the SID between the tube and the bucky. The "DEG" shows the current angle of the tube. Whenever the tube is tilted, the screen changes to a landscape screen or a portrait screen for convenience.

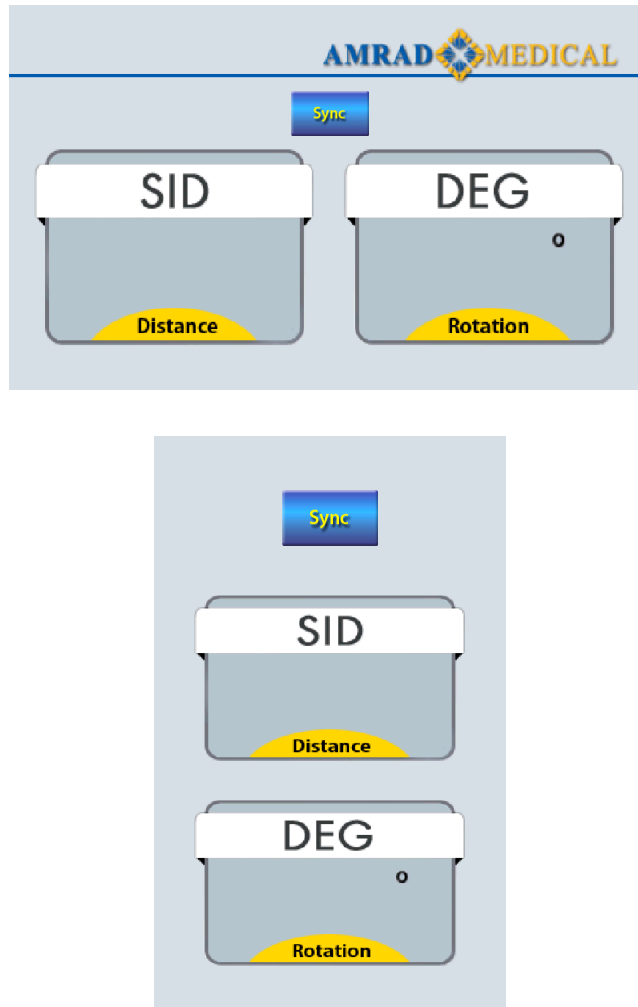



Figure 3-10. OP Display

Graphic	Description
	<p>This button activates the auto-tracking function between the <u>bucky stand</u> and the <u>tube stand</u> by rotating the tube head to face toward the bucky stand and touching the button on the screen once. Then the tube head will move up or down to align the center of the bucky.</p> <p>After that, when the bucky moves up or down, the tube head will automatically track along the bucky. Pressing this button again will deactivate the function.</p>

3.3.3 Auto-Tracking Feature (Chest Position)

When the SST-3100 system is in the chest position as shown below,  button is activated. By pressing the activated  button, the bucky stand and the tube stand will be synchronized.

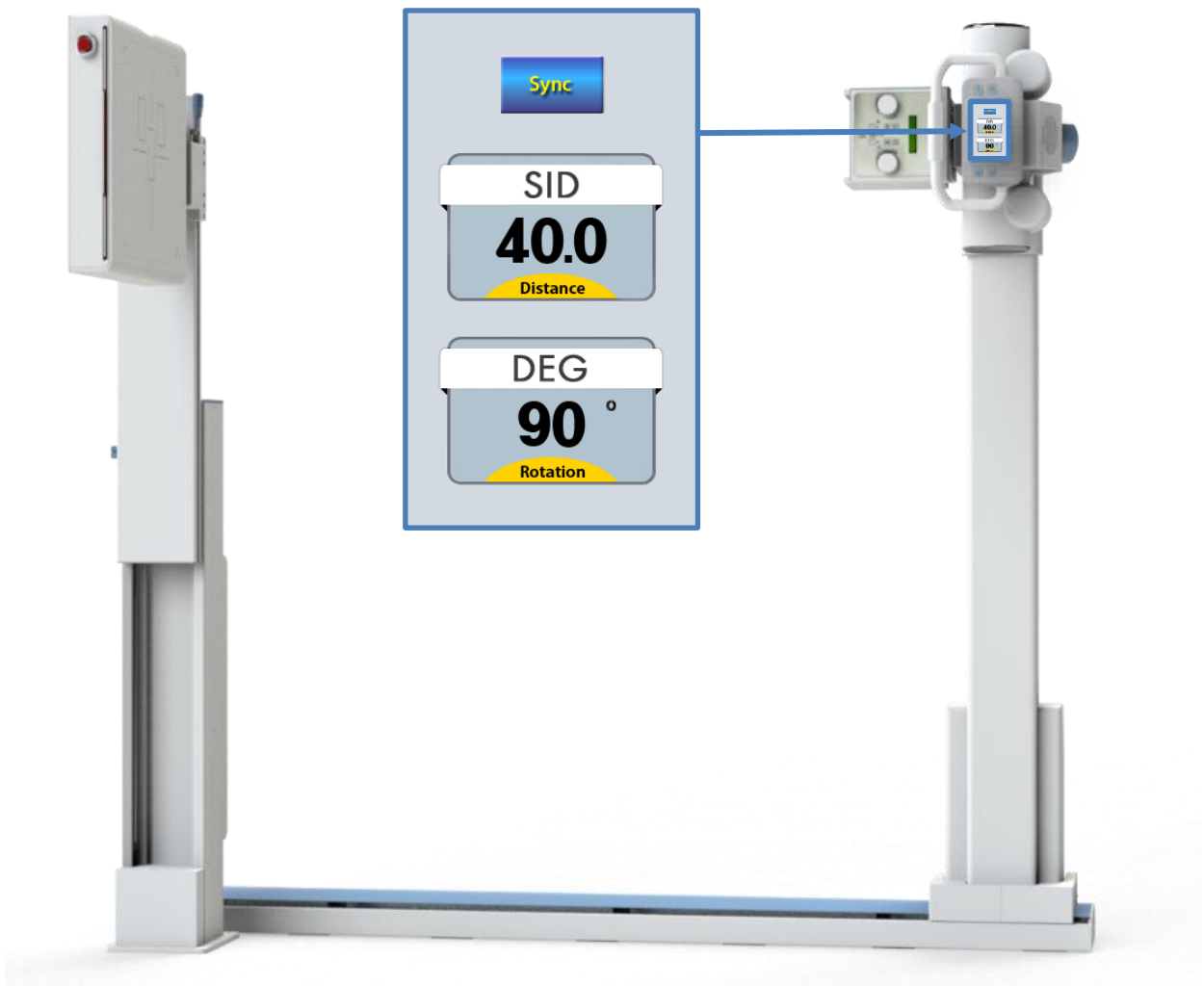
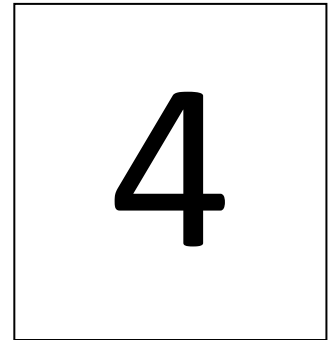

Figure 3-11. Auto-tracking feature

Calibration



4.1 Introduction

This chapter describes the calibration procedures and details for SST-3100.

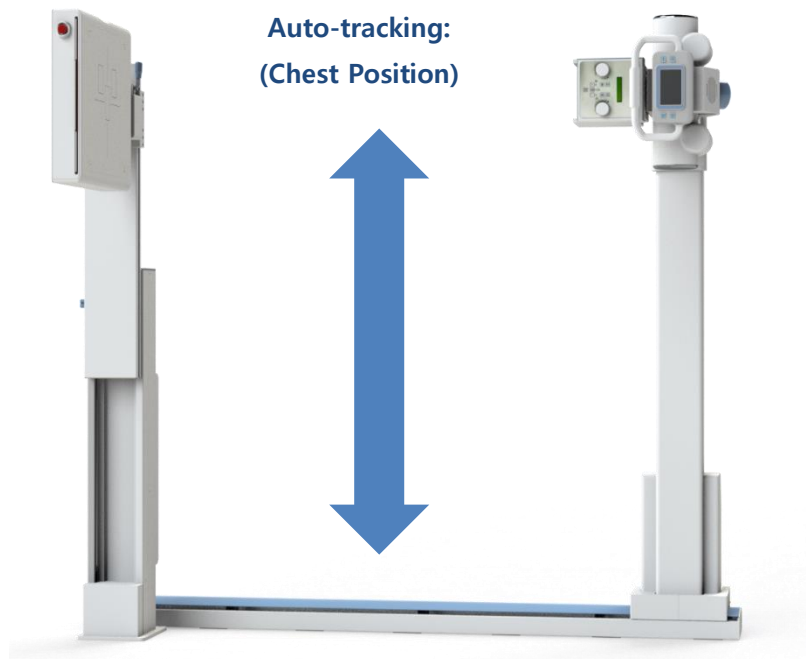

Figure 4-1. Auto-Tracking

4.2 Calibration Procedure

It is necessary to learn about the entire calibration procedure of the SST-3100 system. Perform the calibration referring to the information in this chapter.

4.2.1 Entering Calibration Mode

The system calibration shall proceed with the operation console of the tube stand. Turn the power ON and touch "SID" and "DEG" icons alternately twice in the order of "SID => DEG => SID => DEG" on the main screen.



Figure 4-2. Operation Console

The figure below shows the display of the calibration mode.

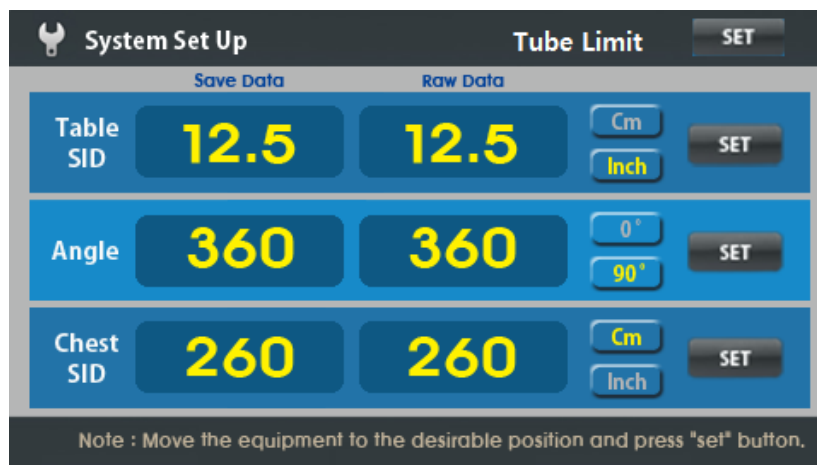

Figure 4-3. Calibration Mode

4.2.2 Procedure & Description

For the setting of the entire system and the auto-tracking between the bucky stand and the tube stand, proceed in the following order.

- 1) On the calibration screen, press the "SET" button shown in the figure below to initialize.

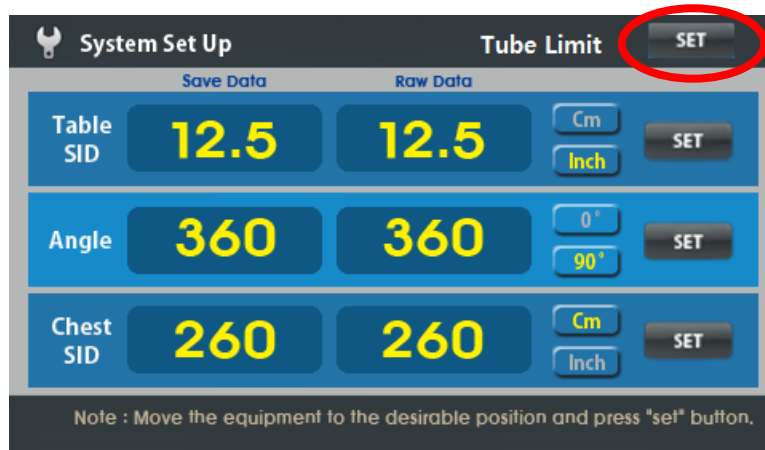

Figure 4-4. "SET" button in Calibration screen

- 2) Make the horizontal angle of the tube head at 0° using a water level.

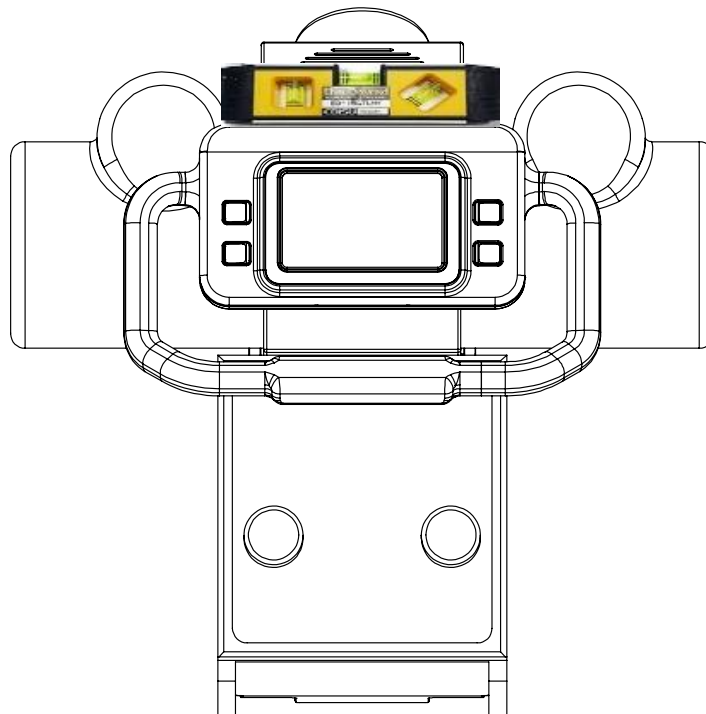

Figure 4-5. Tube head angle adjustment

- 3) Press the "SET" button of angle menu on the calibration screen.
 The position of the tube angle 0° will be saved as the "Save Data" changes to 0.
 As saving the position of the tube angle 0°, the position of 90° will be automatically saved.

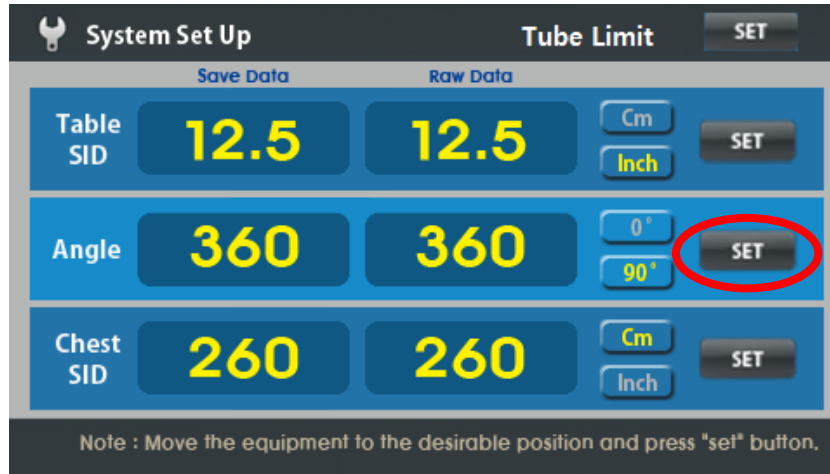

Figure 4-6. Angle set in Calibration screen

- 4) Referring to the following figure, adjust the SID to 40 inches and the height of the bucky to 450 mm from the floor to the center of the bucky.

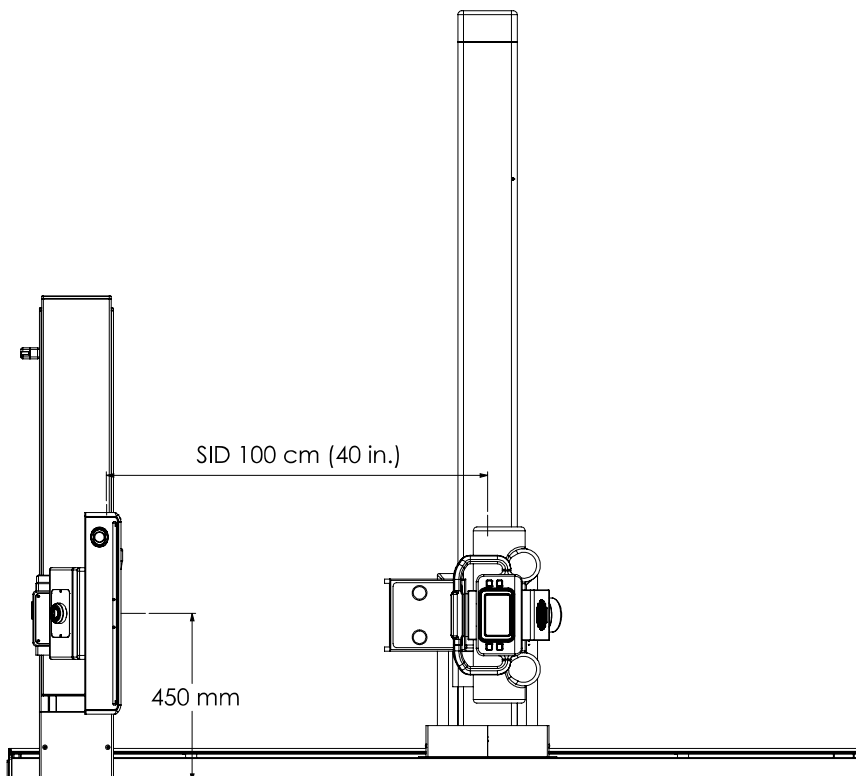

Figure 4-7. Adjusting chest position SID 100cm (40 in.)

- 5) On the calibration screen, press the "Inch" button on the "Chest SID" and then press the "SET" button as the following figure.

As the "Save Data" becomes 40.0 inches, the SID position for 40 inches between the bucky stand and the tube stand will be saved. The position of the highest S/W limit and lowest S/W limit of the bucky stand will be saved as well.

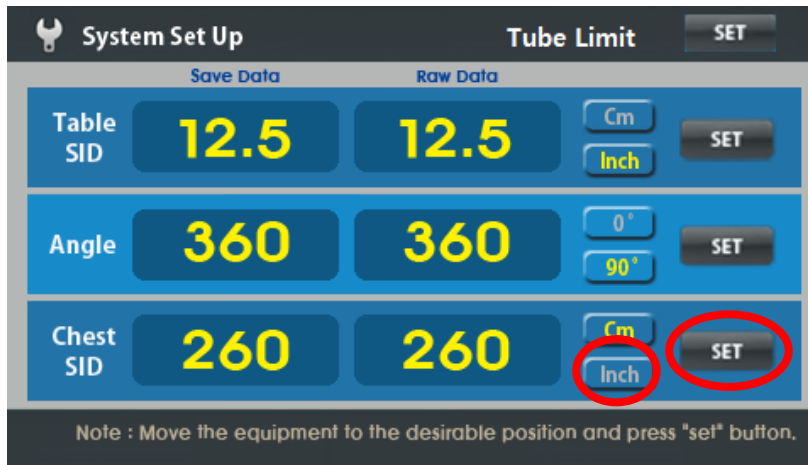

Figure 4-8. Chest SID set in Calibration screen

- 6) After saving the S/W limits, move on to the "Table SID".

When the bucky stand is in the table position as shown below, the bucky can only move up to the position, 630 mm from the floor to the bucky surface.

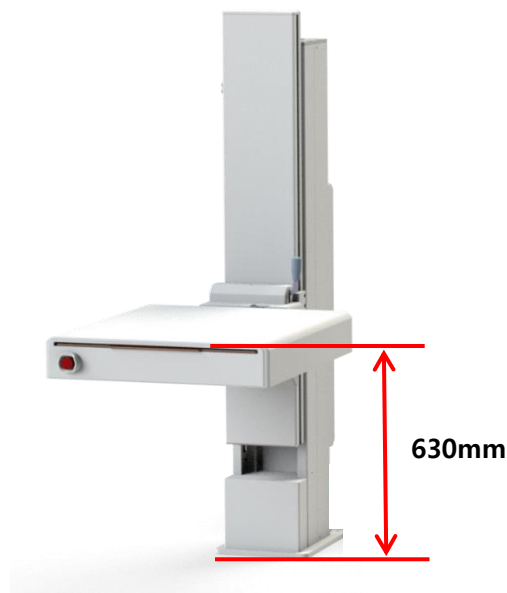

Figure 4-9. Table SID set in Calibration screen

- 7) Referring the following figure, make the SID 40 inches in the table position.

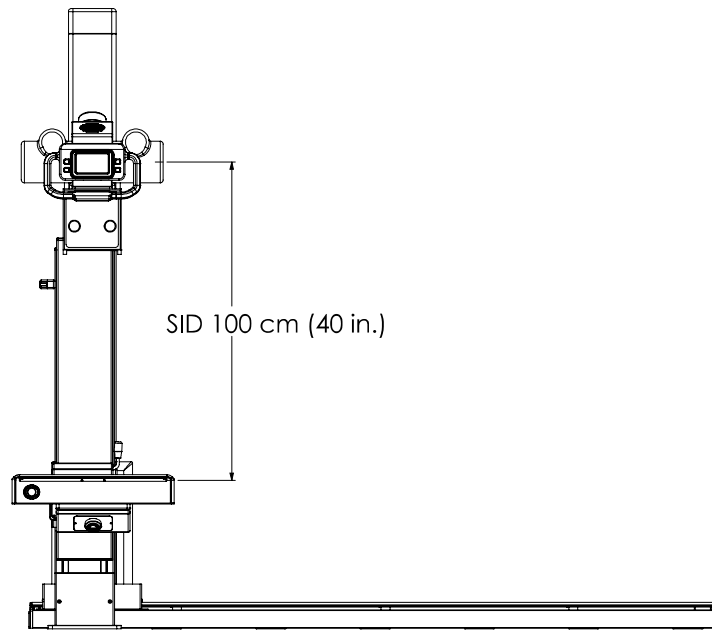

Figure 4-10. Adjusting table position SID 100 cm (40 in.)

- 8) On the calibration screen, press the "Inch" button on the "Table SID" and then press the "SET" button as the following figure. As the "Save Data" becomes 40.0 inches, the SID position for 40 inches between the bucky stand and the tube stand is saved.

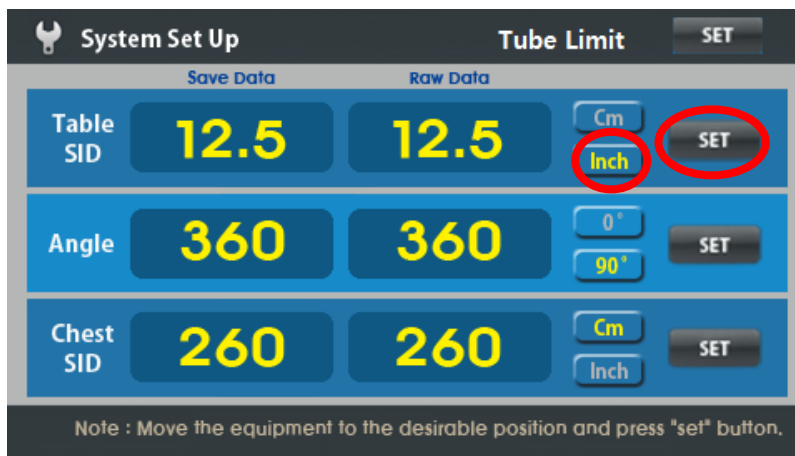

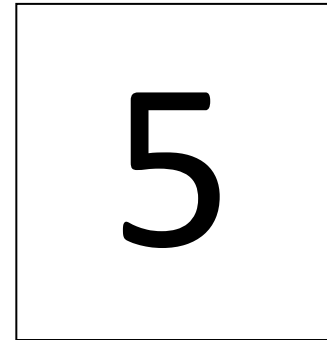

Figure 4-11. Table SID set in Calibration screen



Press the  button to save the calibration data and exit to the user mode. If the power is turned off without exiting the calibration mode, the data won't be saved.

Periodic Maintenance



5.1 Introduction

In order to ensure continued safe performance of the equipment, a periodic maintenance program must be established. It is owner's responsibility to supply or arrange for this service.

5.2 Maintenance Schedule

What to do	When to do it
Operator tasks	Every week or as needed
Service tasks	Refer to "5.2.2 Service Tasks"

Table 5-1. Maintenance schedule

Note

Due to varying operating conditions, the procedures listed below may have to be performed at greater or lesser intervals. You may have to adjust intervals according to your unit's performance.

5.2.1 Operator Tasks

Tools Required:

- Cleaning wipes
- Non-abrasive, hospital-grade cleaner



Warning

Turn off all electrical power to the unit and all its peripheral equipment (generator, wall stand, etc.) at power sources before service. Also, make sure that power sources are locked out and tagged "Equipment Being Serviced" before service. Some components inside of the equipment have power sources other than that of the unit itself. That's why all peripheral equipment must be turned off. You could get seriously injured if you do not.



Warning

This equipment is not classified as anesthetic-proof and may ignite inflammable anesthetics. Flammable agents used for skin cleaning or disinfecting may also produce an explosion hazard.

- Ensure the power has been disconnected and that the emergency switches have been activated, before starting any cleaning operation.
- Ensure no liquid gets into the unit.
- Do not immerse the equipment, including any components or accessories, in liquid.
- Do not autoclave the equipment, including any component or accessories.
- Do not use water. Water can short-circuit the electrical installation and cause corrosion to mechanical parts.
- Do not use acid or abrasive products.
- Use only a dry cloth to clean chrome-plated parts.
- For safety reasons, do not spray disinfectants.
- Do not spray cleaning or disinfection solution directly on the equipment.
- When disinfecting the examination room, ensure the unit is covered with plastic sheets.

5.2.2 Service Tasks

Only service personnel specially trained for medical X-Ray equipment should handle the service or maintenance tasks of the equipment.

What to do	When to do it
Bucky stand: Check Up/Down Chain locking bolt/nut	1 year
Bucky stand: Check the steel wires of the column	1 year
Bucky stand: Check the Up/Down motor	1 year
Tube stand: Check the Up/Down motor	1 year
Tube stand: Check the steel wires of the column	1 year
Bucky stand & Tube stand: Check the anchor bolts on floor	1 year
Bucky stand: Check if there is an oil leakage on the motor part	6 months
Bucky stand: Check condition of the detector bracket bolts	6 months
Tube stand: Check the tube locking bolt	6 months

Table 5-2. Service Tasks

Illustrated Parts List

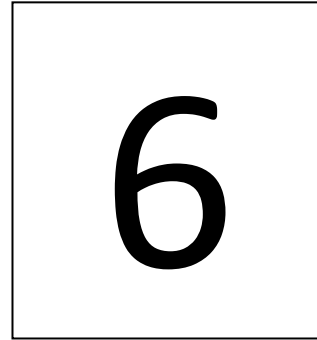

6.1 Introduction

This chapter describes about the parts and assemblies require for reference in case of ordering spare parts or service parts of SST-3100.

6.2 Electronic Parts

Refer to the following description for the major electronic parts needed for the SST-3100 system.

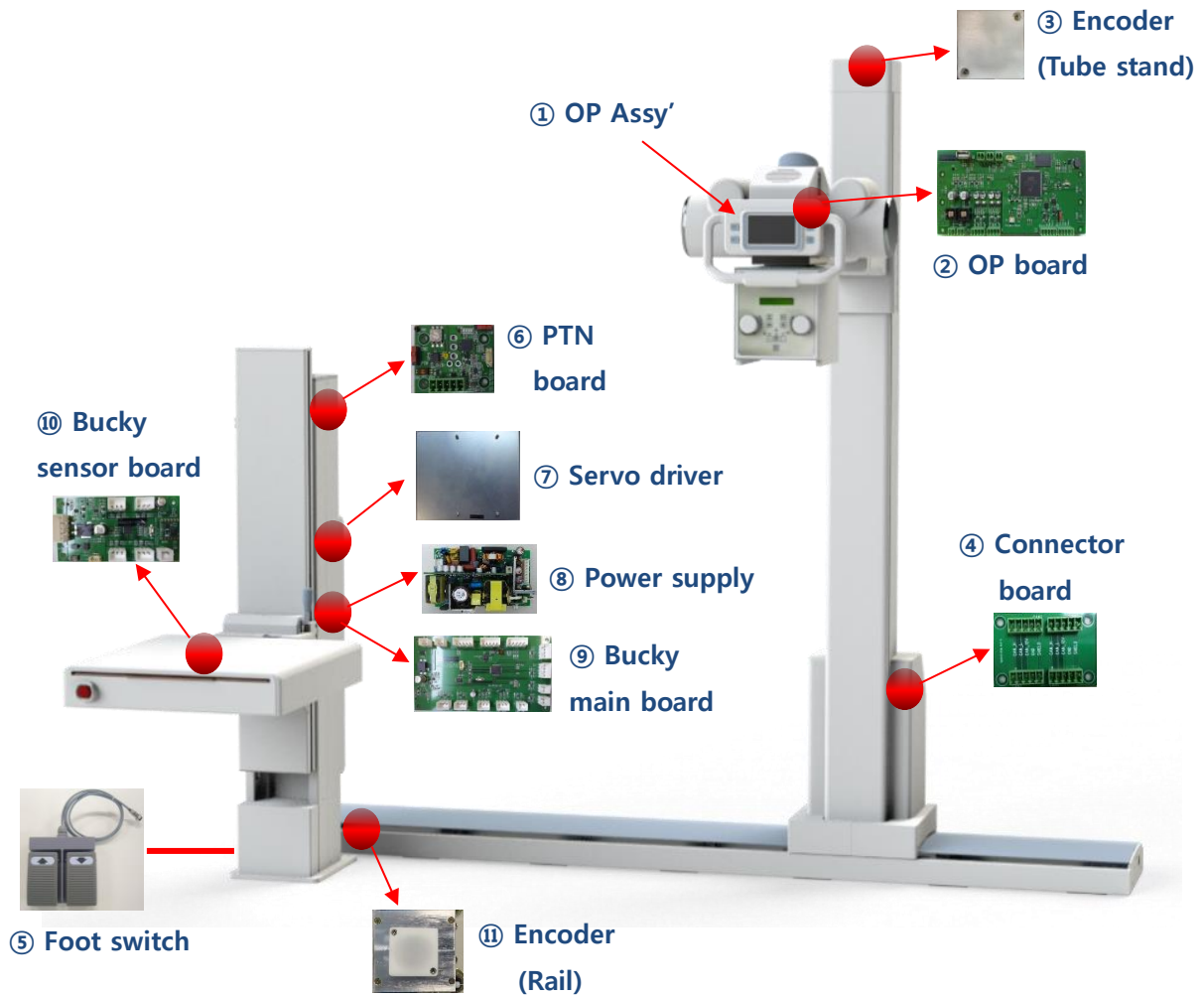



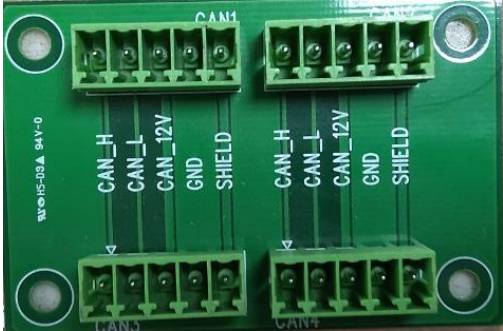

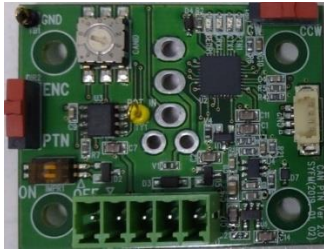





Figure 6-1. Electronic Parts Diagram

No.	Item No.	Description
1	LSS2-OP_V1	<p>5" Control panel assy'</p> 
2	SST31-OPbd	<p>OP board for the tube stand</p> 
3	SST31-ST-EN	<p>Encoder for the tube stand</p> 
4	SST31-CNbd	<p>Connector board for the tube stand</p> 

5	SST31-Footswitch	<p>Foot switch for the bucky stand</p> 
6	SST31-PTNbd	<p>PTN (Potentiometer) board for the bucky stand</p> 
7	SST31-SERVO-DRV	<p>Servo driver for the bucky stand</p> 
8	SYFM-SMPS-01	<p>Power supply for the bucky stand</p> 
9	SST31-Mainbd-BKY	<p>Main board for the bucky stand</p> 

<p>10</p>	<p>SST31-sensorbd-BKY</p>	<p>Sensor board for the bucky enclosure</p> 
<p>11</p>	<p>SST31-Rail-EN</p>	<p>Encoder for the tube rail</p> 

Table 6-1. Electronic Parts Description

6.2.1 References

Refer to the following pictures for the locations of the electronic parts.

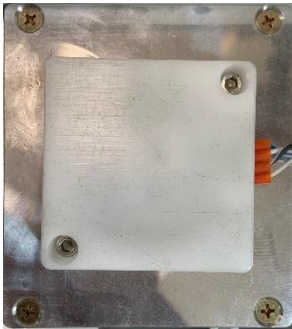
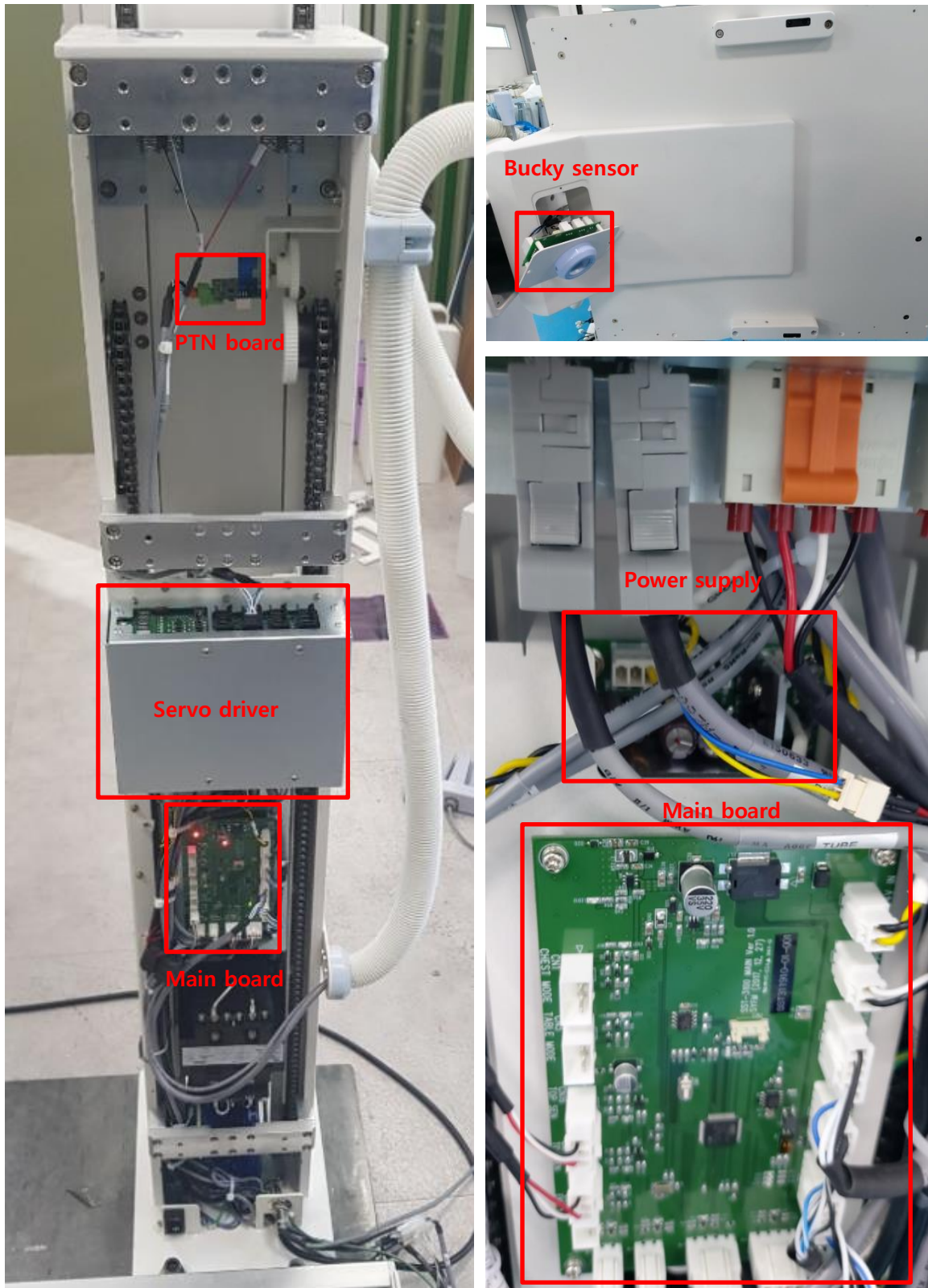

Figure 6-2. Electronic Part Locations (Bucky Stand)

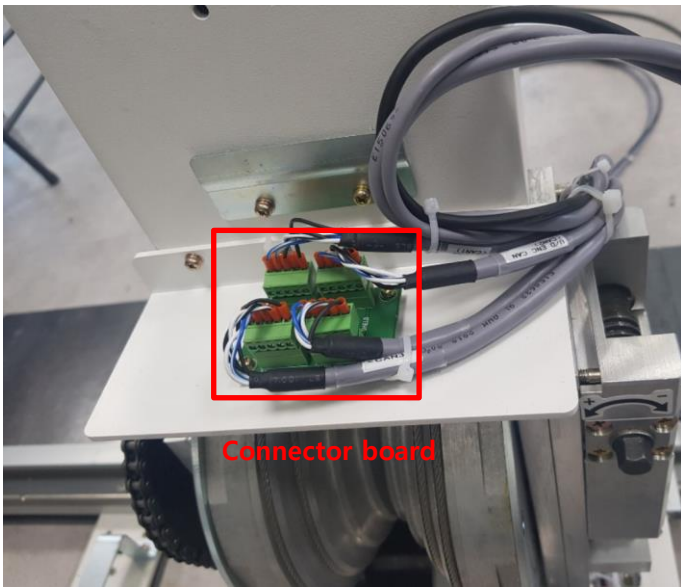
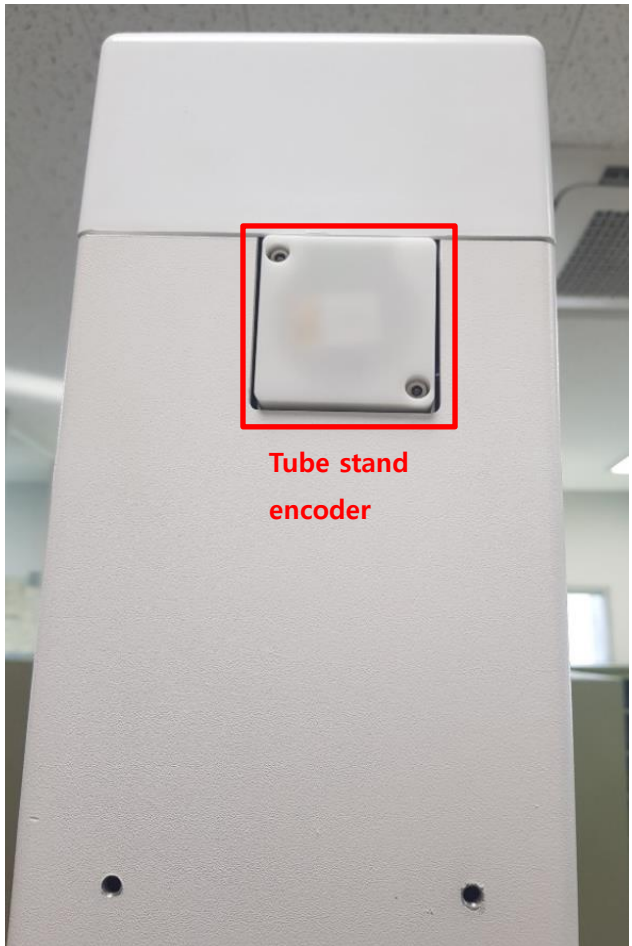
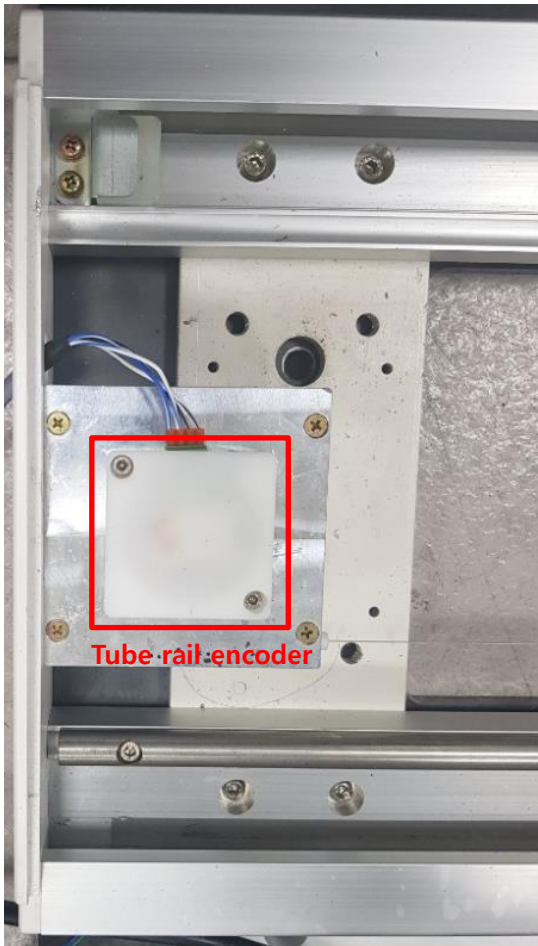

Figure 6-3. Electronic Part Locations (Tube Stand)

6.3 Mechanical Parts

The stands and table are divided into assembly units and described with exploded view as follows.

6.3.1 Bucky Stand

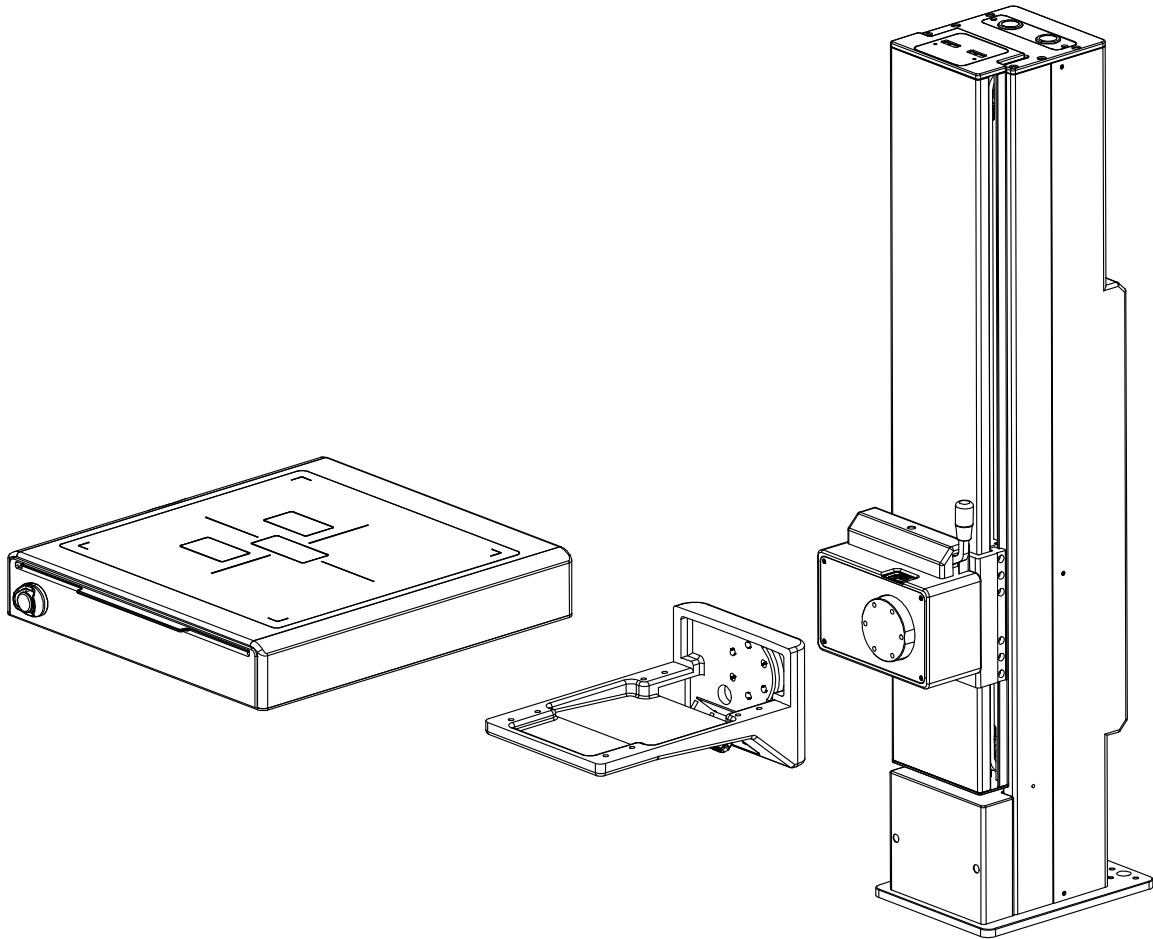

Figure 6-4. Bucky Stand

6.3.2 Tube Stand

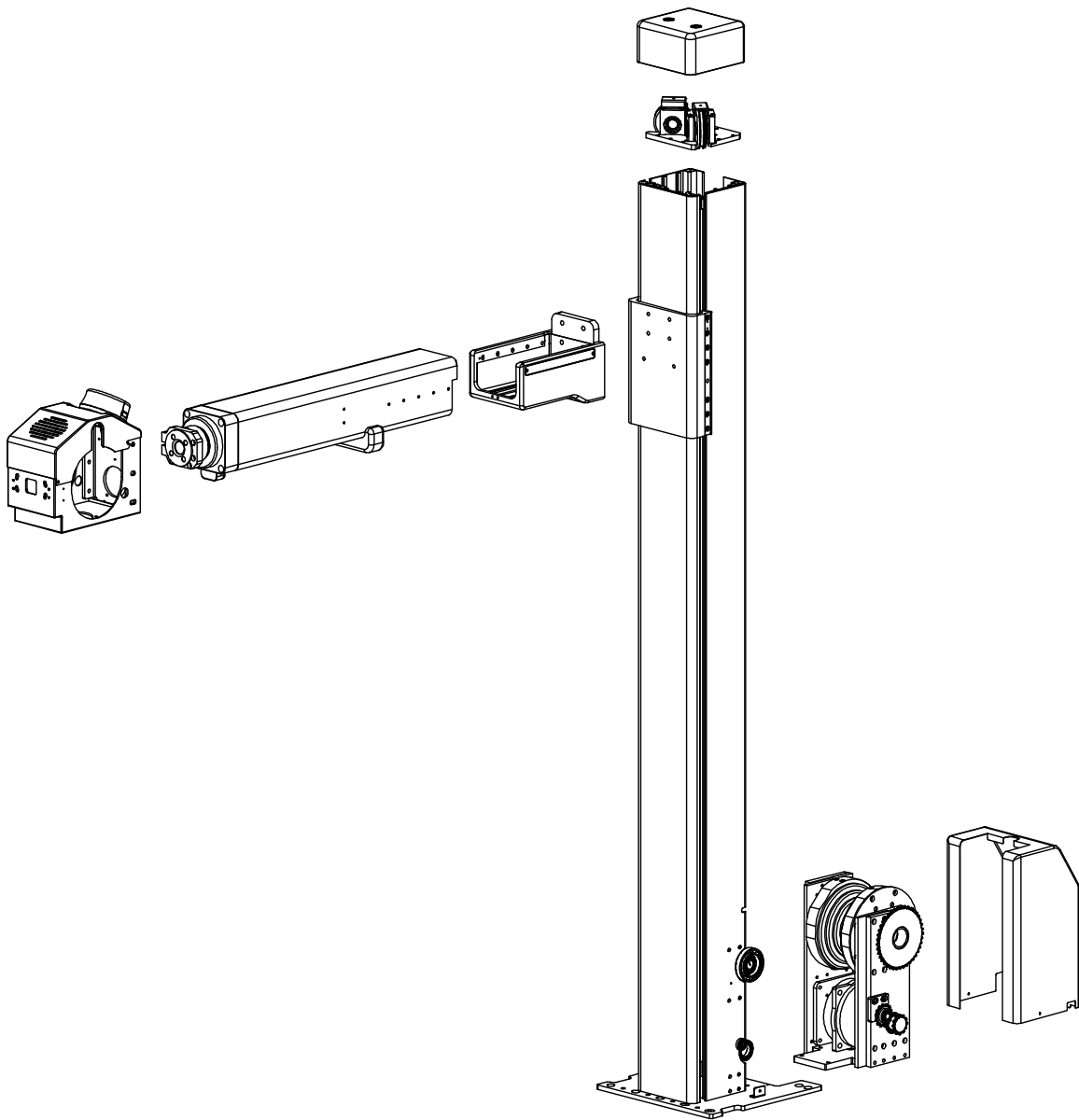

Figure 6-5. Tube Stand

6.3.3 Tube Stand Rail

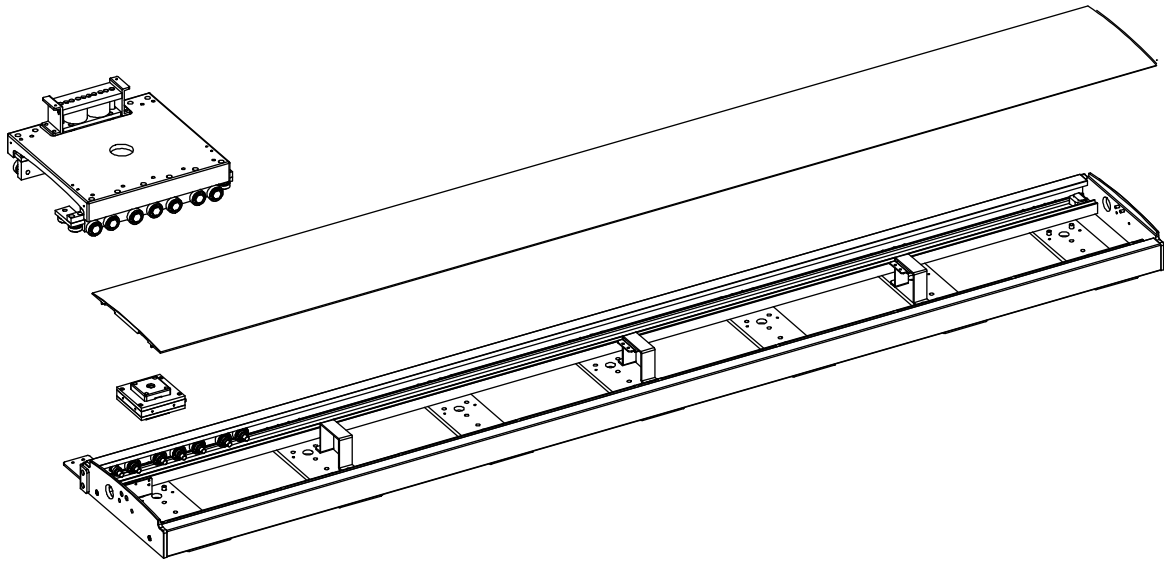

Figure 6-6 Tube Stand Rail

6.3.4 Patient Table (Option)

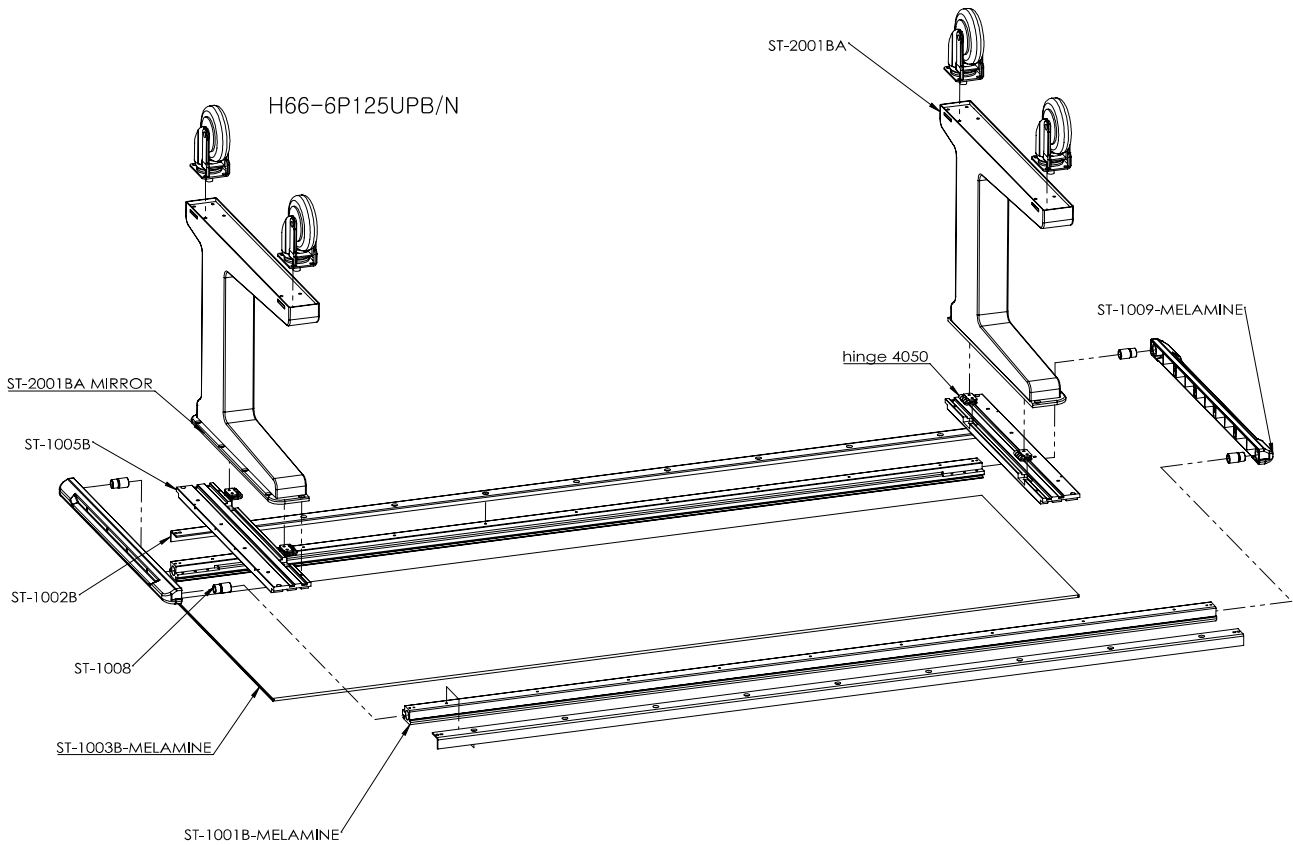
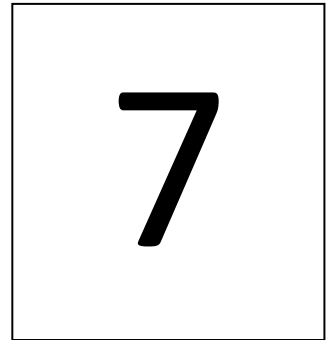

Figure 6-7. Tube Stand Rail

Electrical Schematics



7.1 Introduction

This chapter provides all electrical schematics including block diagrams.

Drawing Description	#Sheets	Current Revision
Block Diagram	1	V1.1
OP board	13	V2.1
Main board	9	V1.0
Sensor board	6	V1.0
Encoder	5	V2.2
PTN board	1	V2.0
Connector board	1	V1.0

Table 7-1. Drawing Information

7.2 Block Diagram

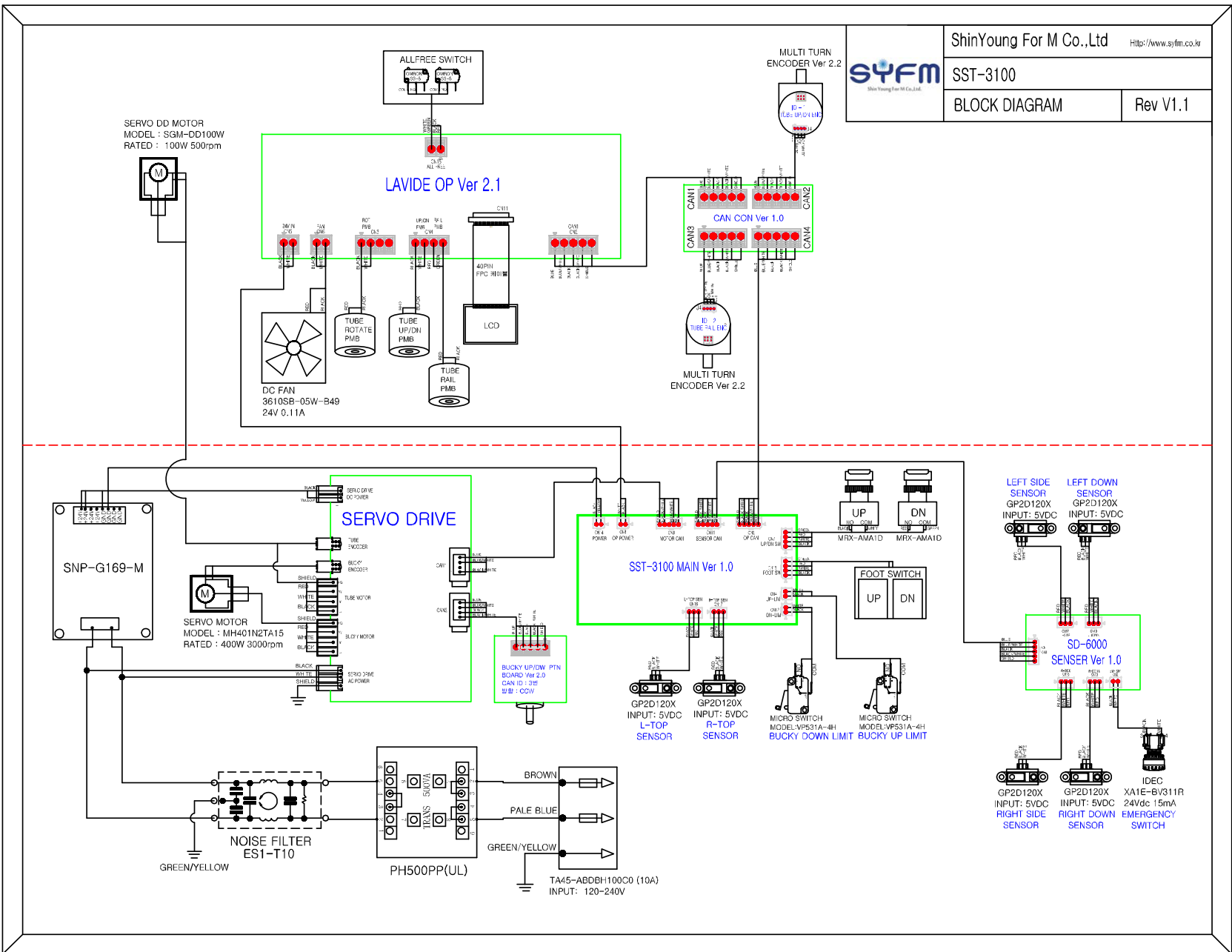

7.3 Schematics

7.3.1 OP Board

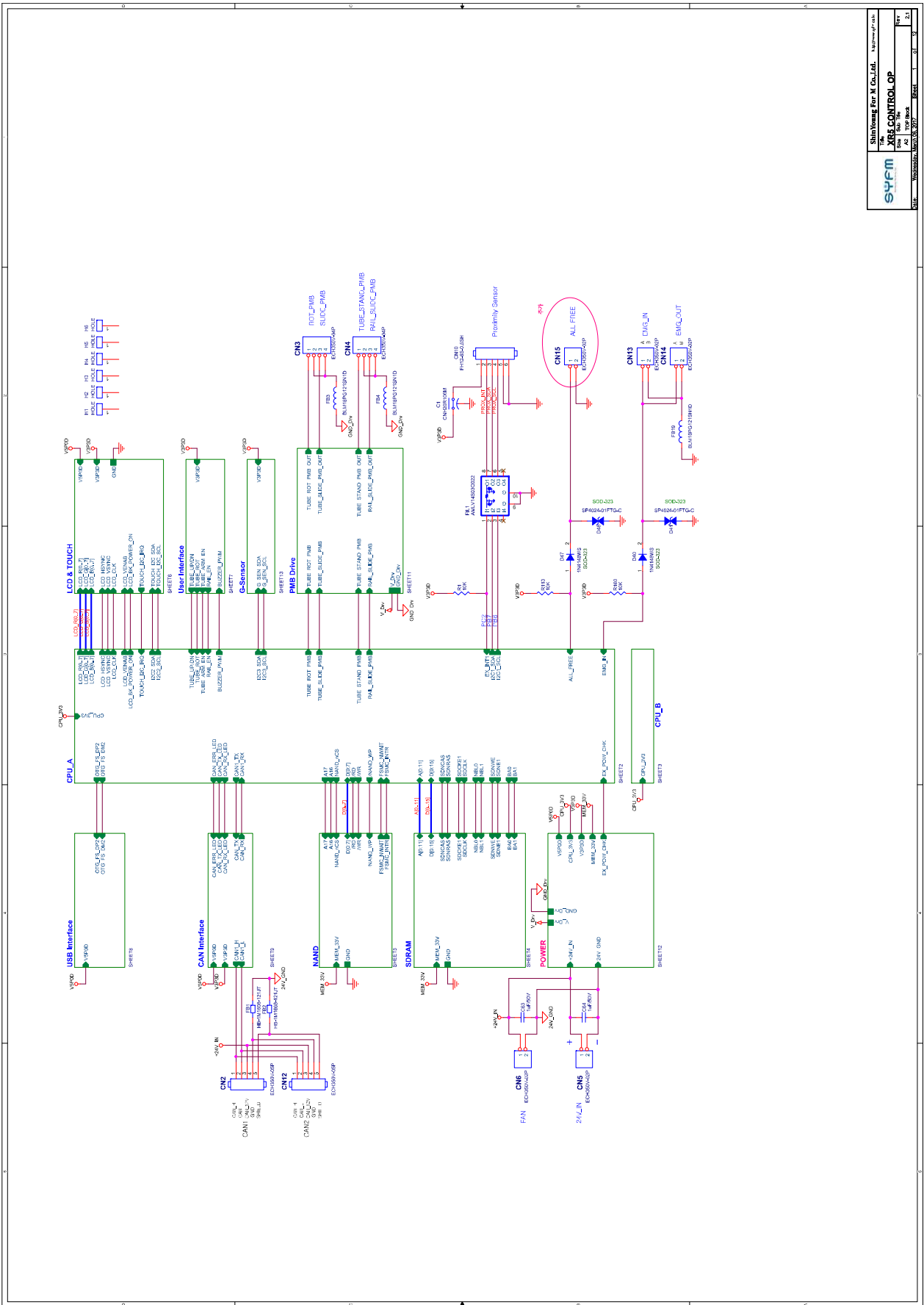

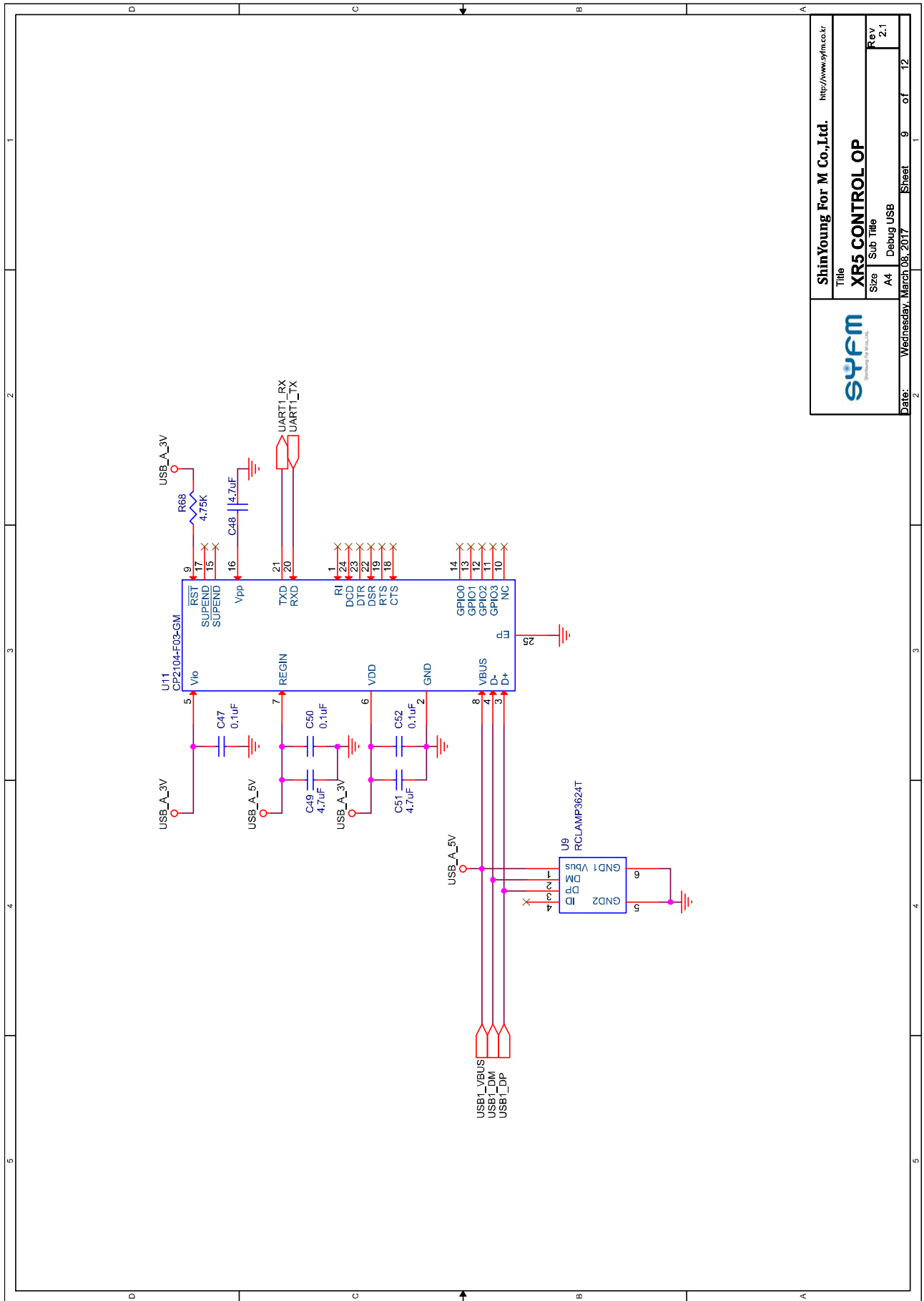

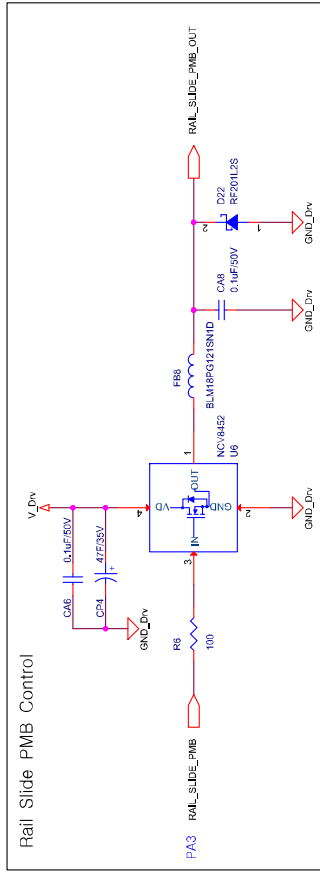
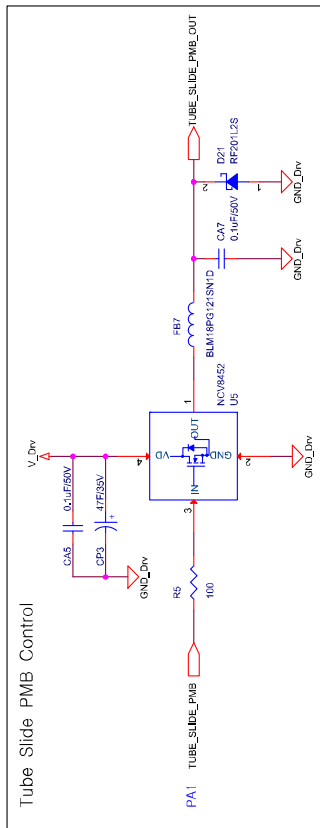
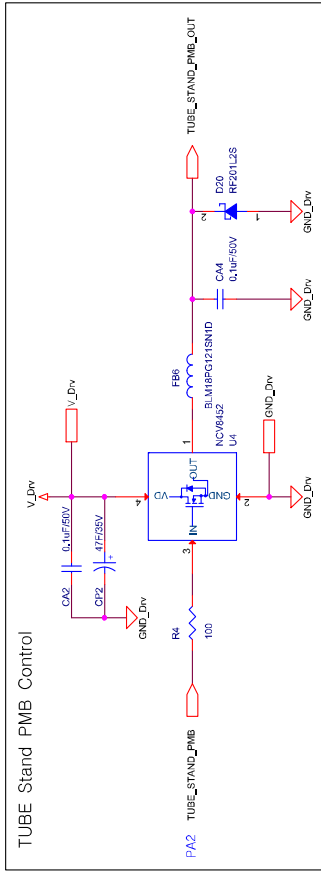
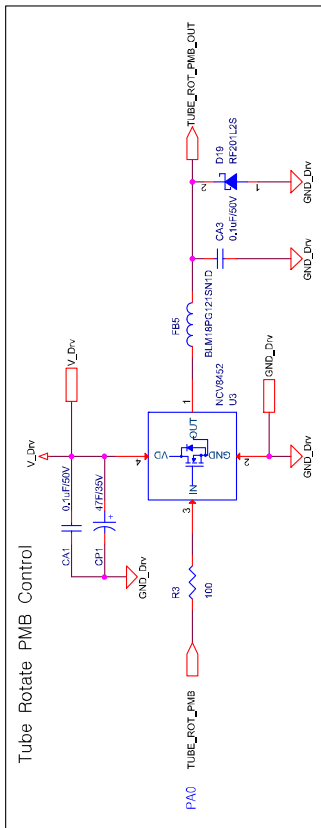

		Date: Wednesday, March 08, 2017	
		Sheet 9	of 12
Title XR5 CONTROL OP		http://www.syfm.co.kr	
Size	A4	Sub Title	Debug USB
Rev	2.1		

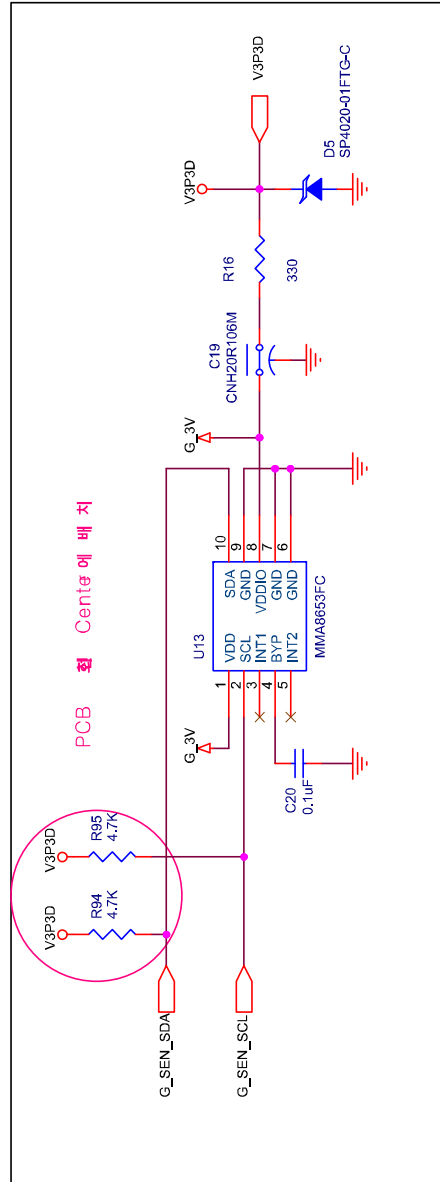

		Shin Young For M Co., Ltd. http://www.syfm.co.kr	
Title	XR5 CONTROL OP		
Size	Sub Title	PMB Drive	Rev. 2.1
Date:	Wednesday, March 08, 2017	Sheet: 2	of 12

G-SENSOR



		ShinYoung For M Co.,Ltd. http://www.syfm.co.kr	
Title XR5 CONTROL OP		Date: Wednesday, March 08, 2017	
Size A4	Sub Title G-Sensor	Sheet 4	of 12
Rev 2.1		2	

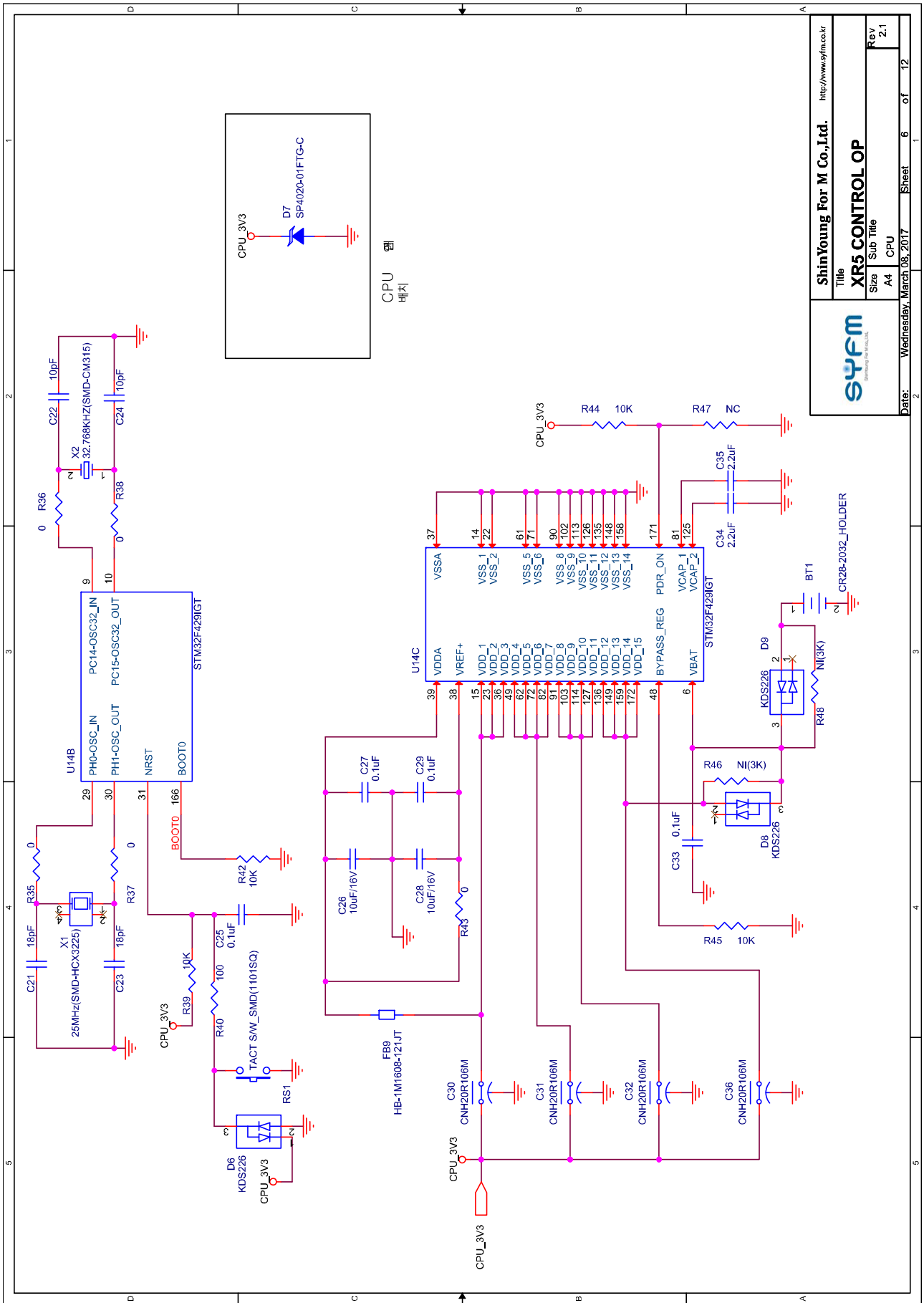

SYFM
ShinYoung For M Co.,Ltd. <http://www.syfm.co.kr>

Title	XR5 CONTROL OP
Size	A4
Sub Title	CPU
Rev	2.1

Date: Wednesday, March 08, 2017 Sheet 6 of 12

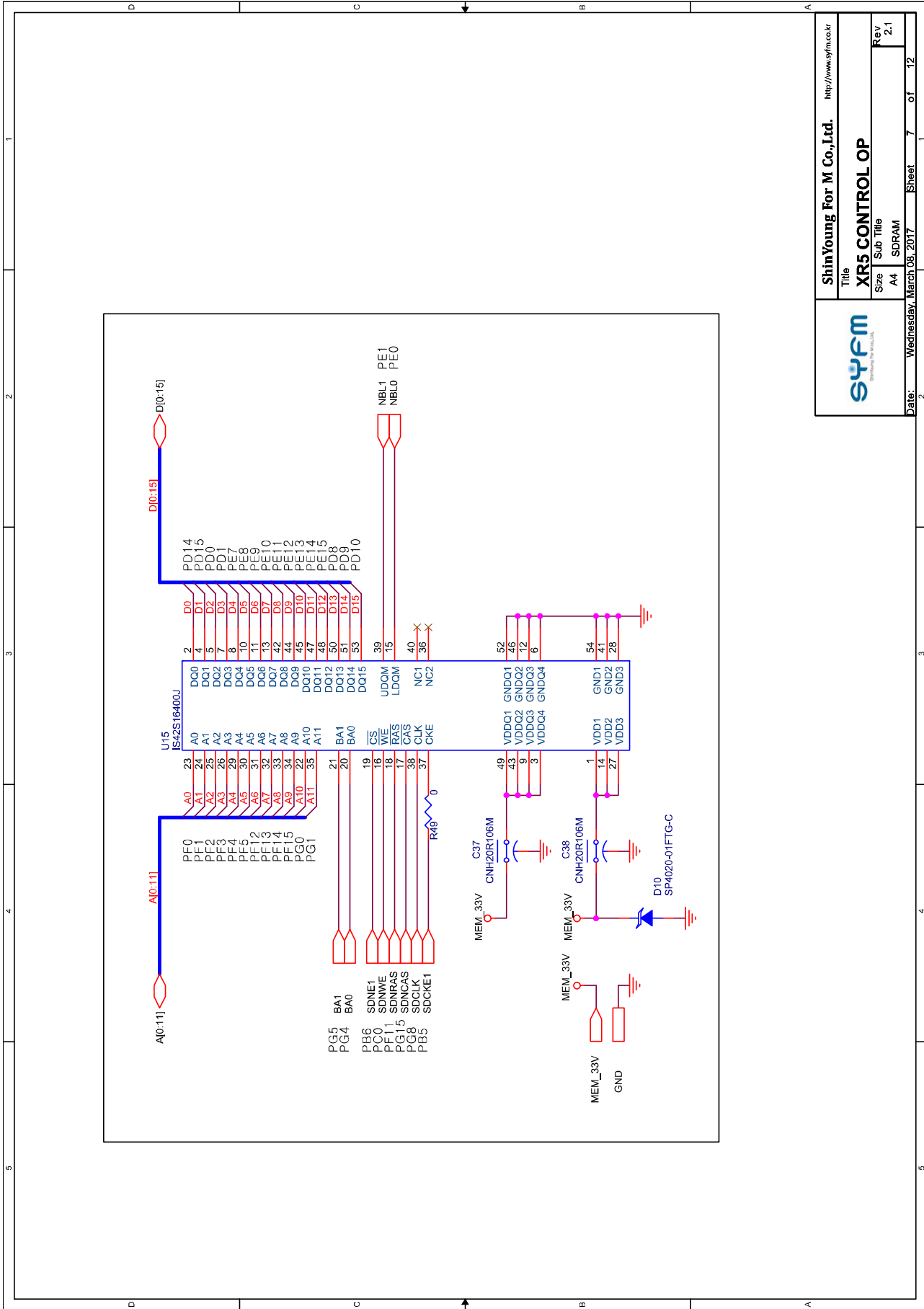

		ShinYoung For M Co.,Ltd. http://www.syfm.co.kr	
Title XR5 CONTROL OP		Sheet 7 of 12	
Size A4	Sub Title SDRAM	Date: Wednesday, March 08, 2017	
Rev 2.1		Rev 2.1	

NAND FLASH_1Gb(128MB)

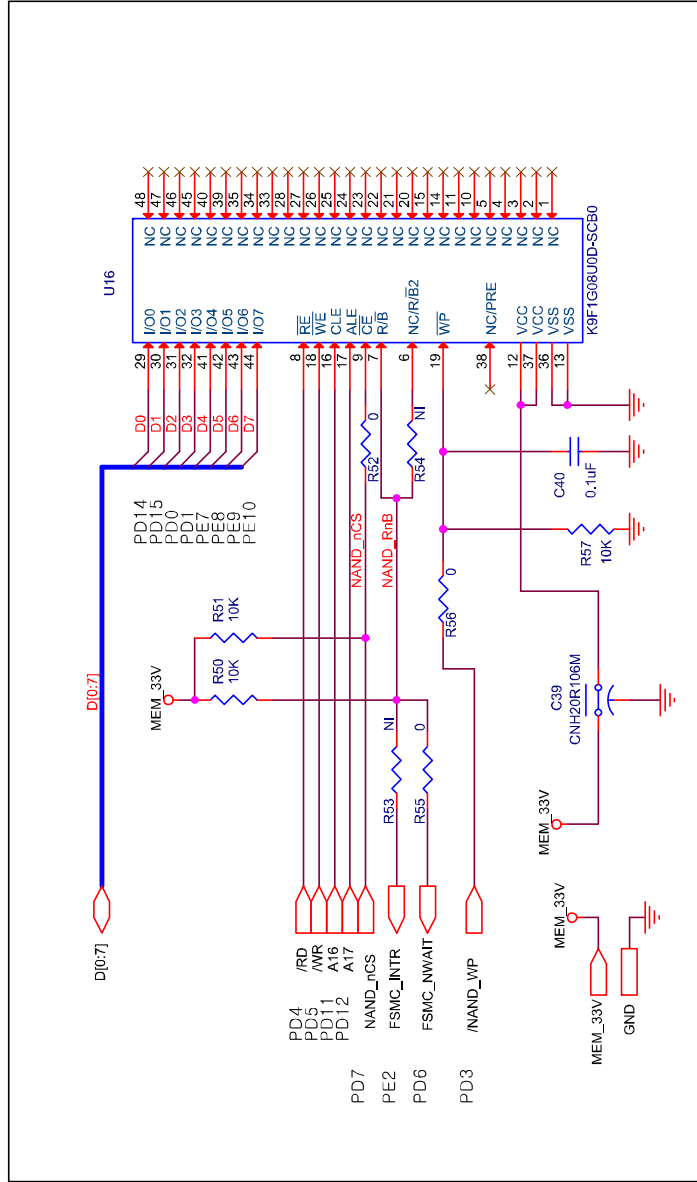

		ShinYoung For M Co.,Ltd. http://www.syfm.co.kr	
Title XR5 CONTROL OP		Rev 2.1	
Size A4		Sub Title NAND Flash Memory	
Date: Wednesday, March 08, 2017		Sheet 8 of 12	

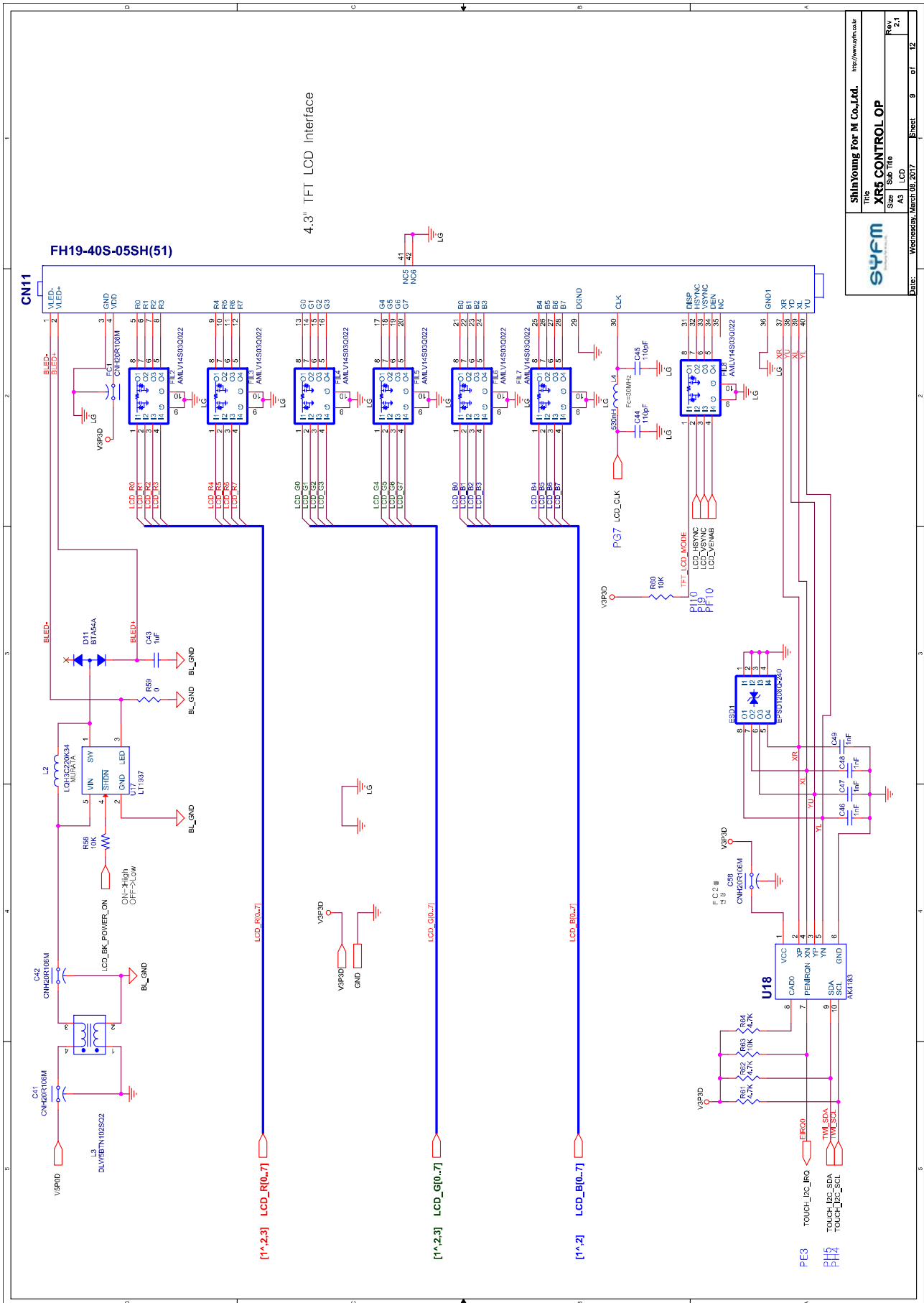

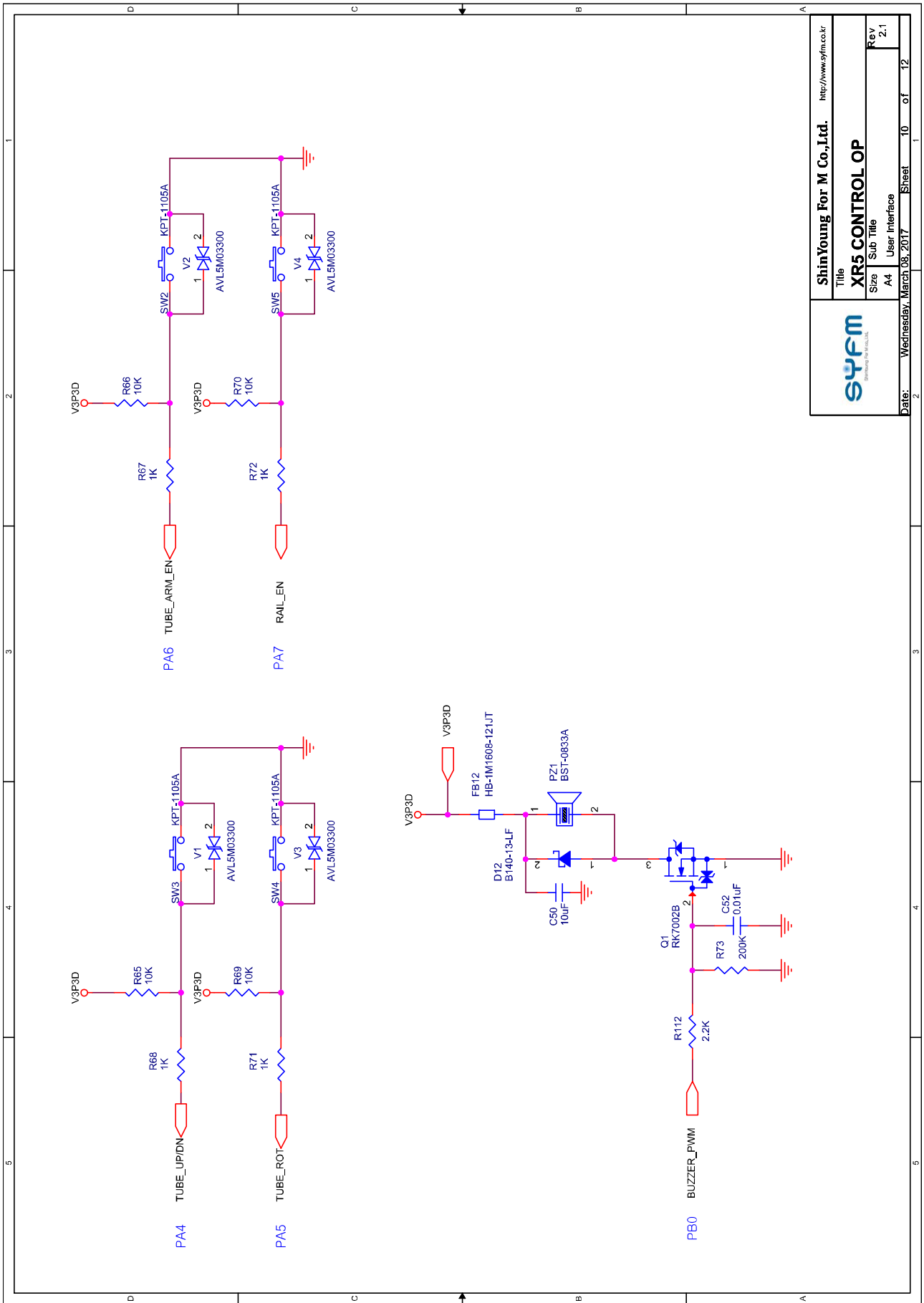

		Date: Wednesday, March 08, 2017	
		Sheet 10 of 12	Rev 2.1
Title XR5 CONTROL OP		http://www.syfm.co.kr	
Size A4	Sub Title User Interface		

7.3.2 Main Board

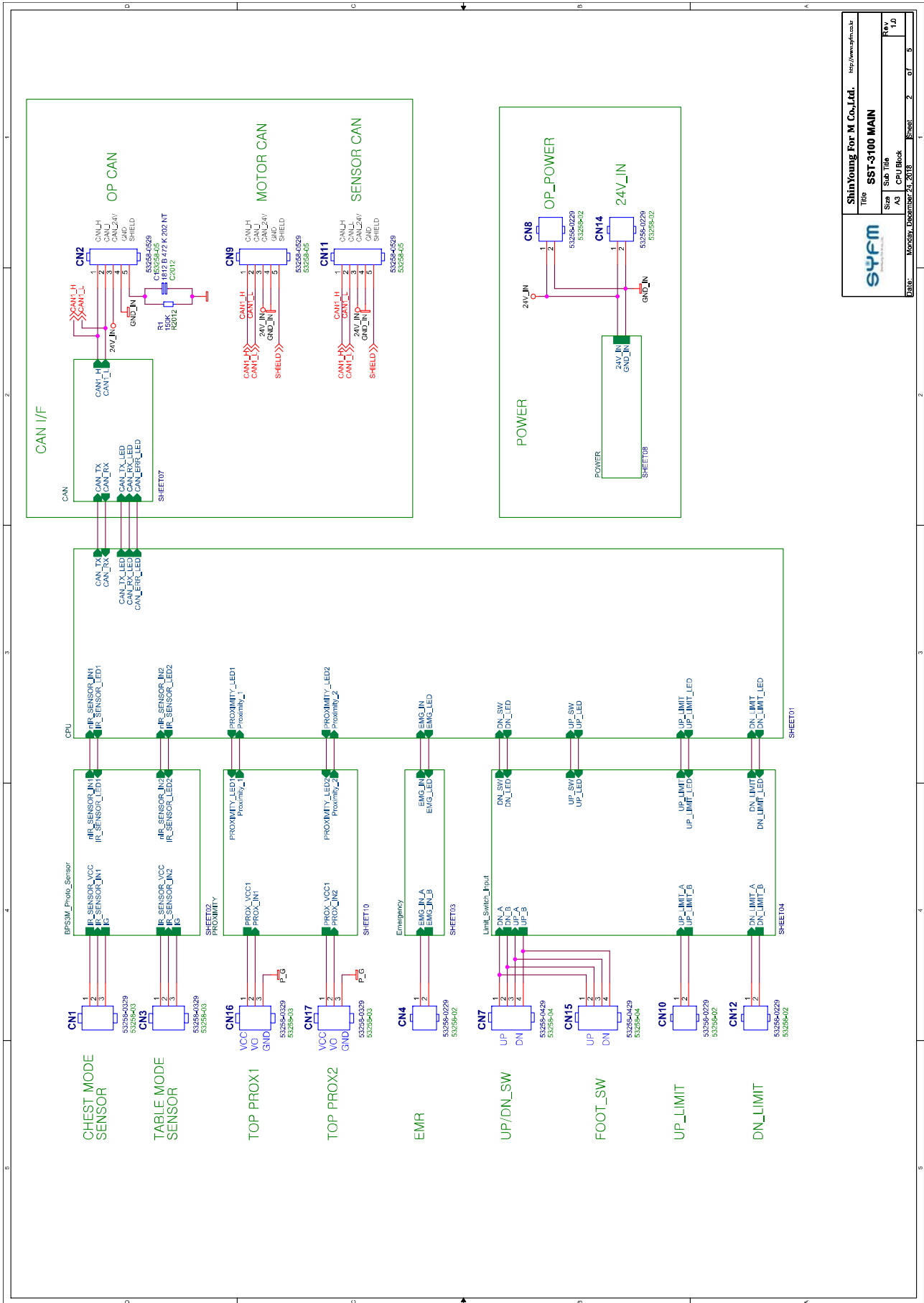

ShinYoung For M Co., Ltd. http://www.syfm.co.kr	
Title	SST-3100 MAIN
Scale	AS
Sheet	43
Sub Title	CPU Back
Date	2018.09.25
Sheet	2
Page	5

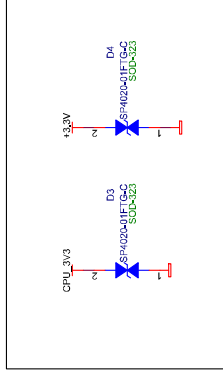
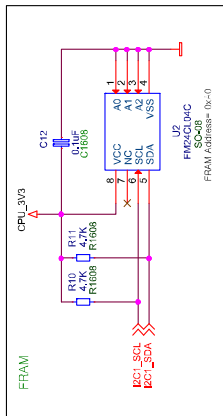
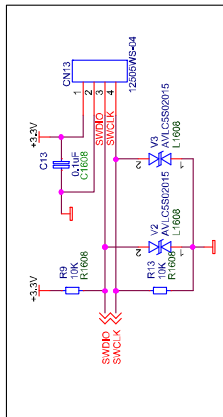
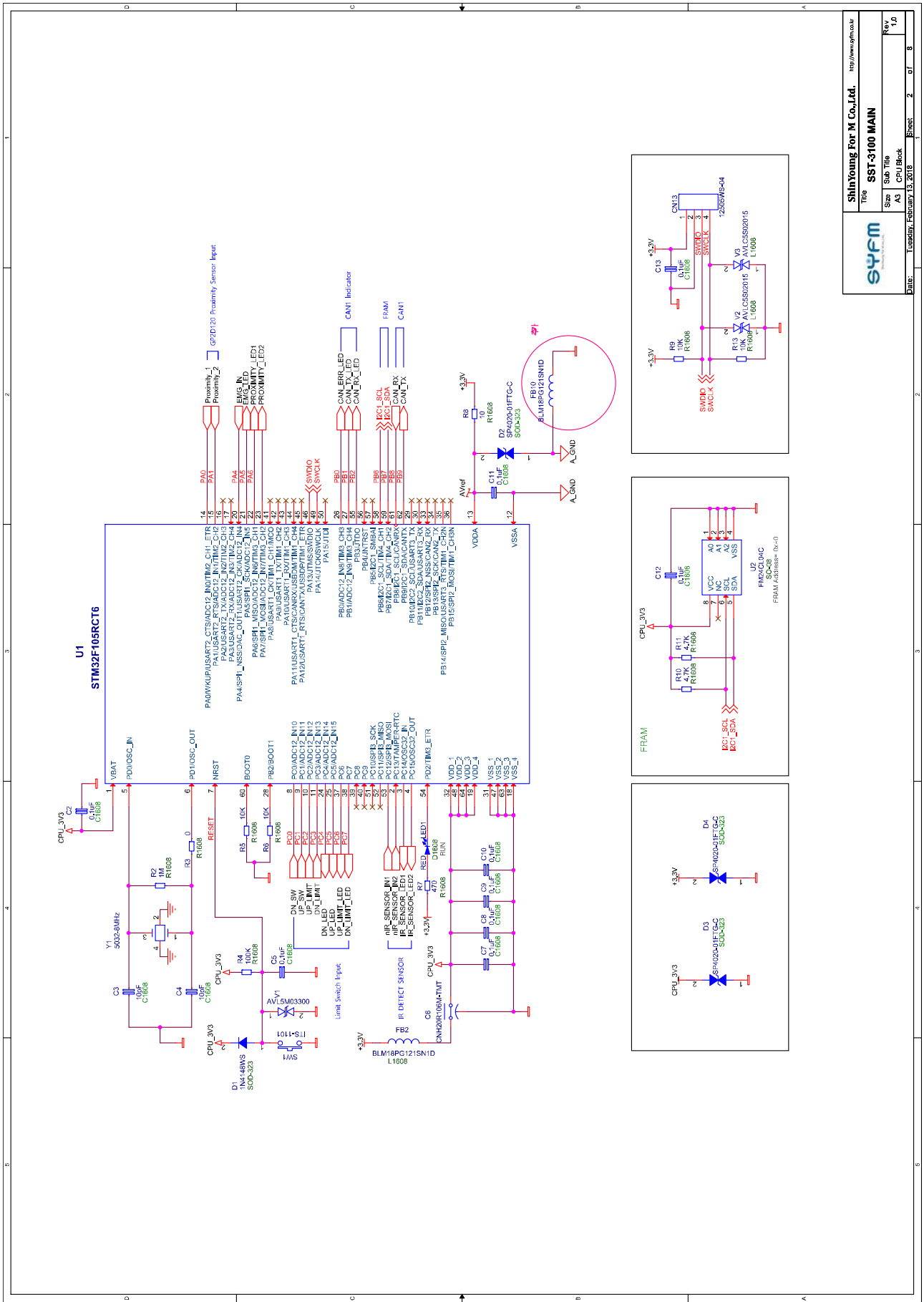

ShinYoung For 'M Co., Ltd.		http://www.sym.co.kr	
Title SST-3100 MAIN			
Size	Sub Title	Rev	
A3	CPU Block	1.0	
Date:	Tuesday, February 13, 2018	Sheet:	2 of 8

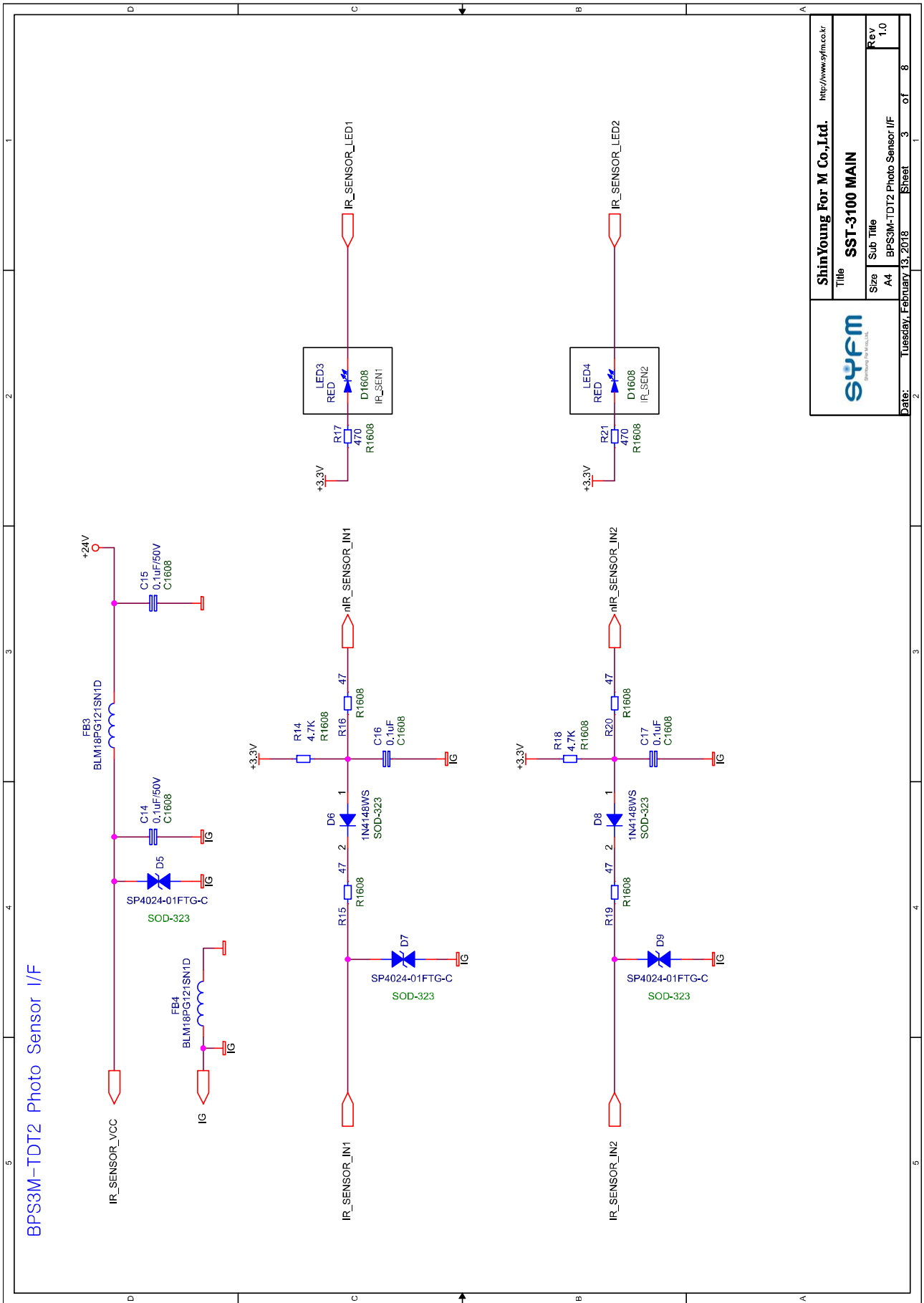

		Title SST-3100 MAIN	
		Size A4	Rev 1.0
Date: Tuesday, February 13, 2018		Sheet 3	of 8

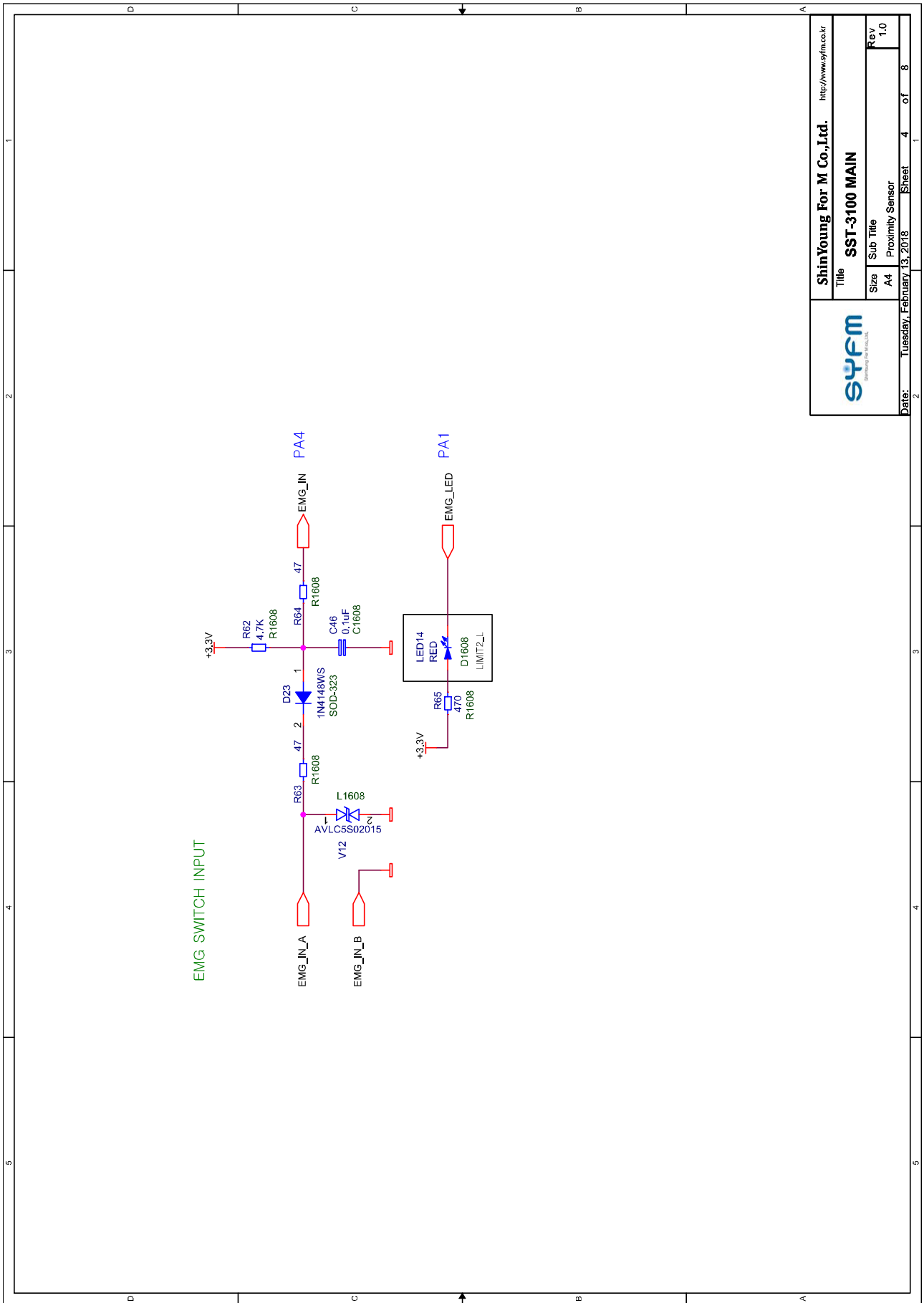

		Title SST-3100 MAIN	
		Sub Title Proximity Sensor	Rev 1.0
Date: Tuesday, February 13, 2018		Sheet 4 of 8	Page 1 of 8

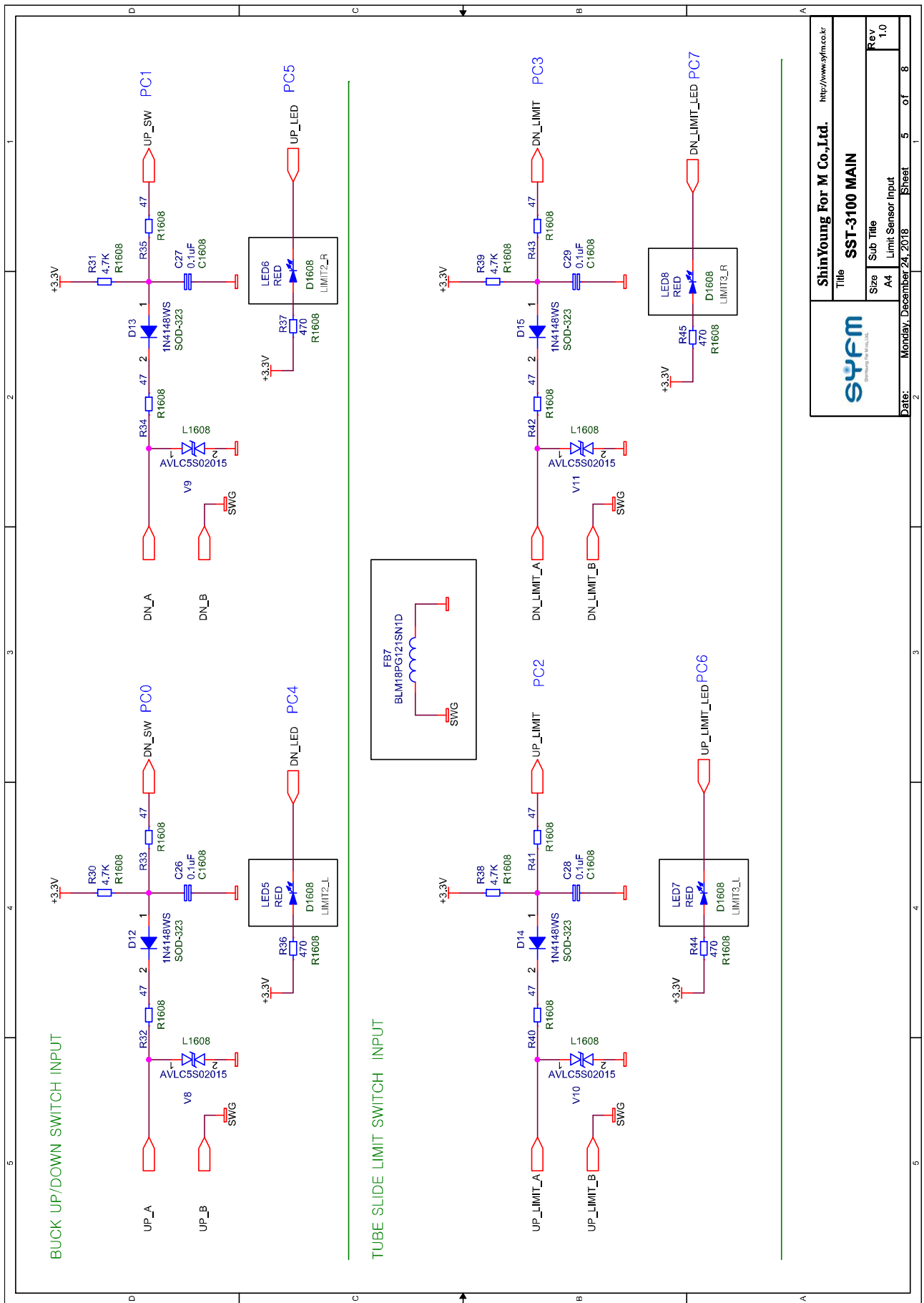

	ShinYoung For M Co.,Ltd. http://www.syfm.co.kr	
	Title SST-3100 MAIN	
Size A4	Sub Title Limit Sensor Input	Rev 1.0
Date: Monday, December 24, 2018		Sheet 5 of 8

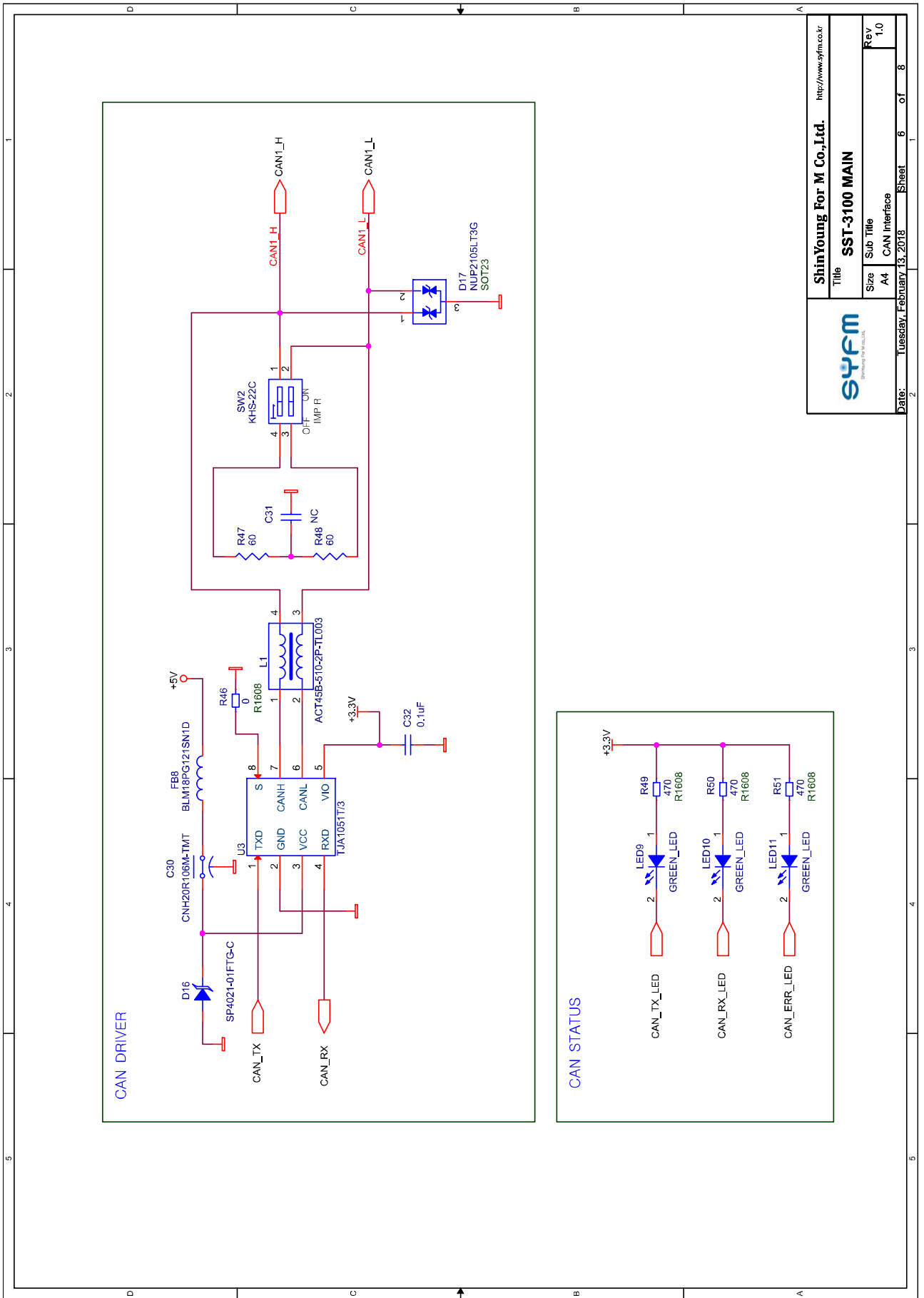

		ShinYoung For M Co.,Ltd. http://www.syfm.co.kr	
		Title SST-3100 MAIN	
Size A4	Sub Title CAN Interface	Sheet 6 of 8	Rev 1.0
Date: Tuesday, February 13, 2018		Sheet 6 of 8	

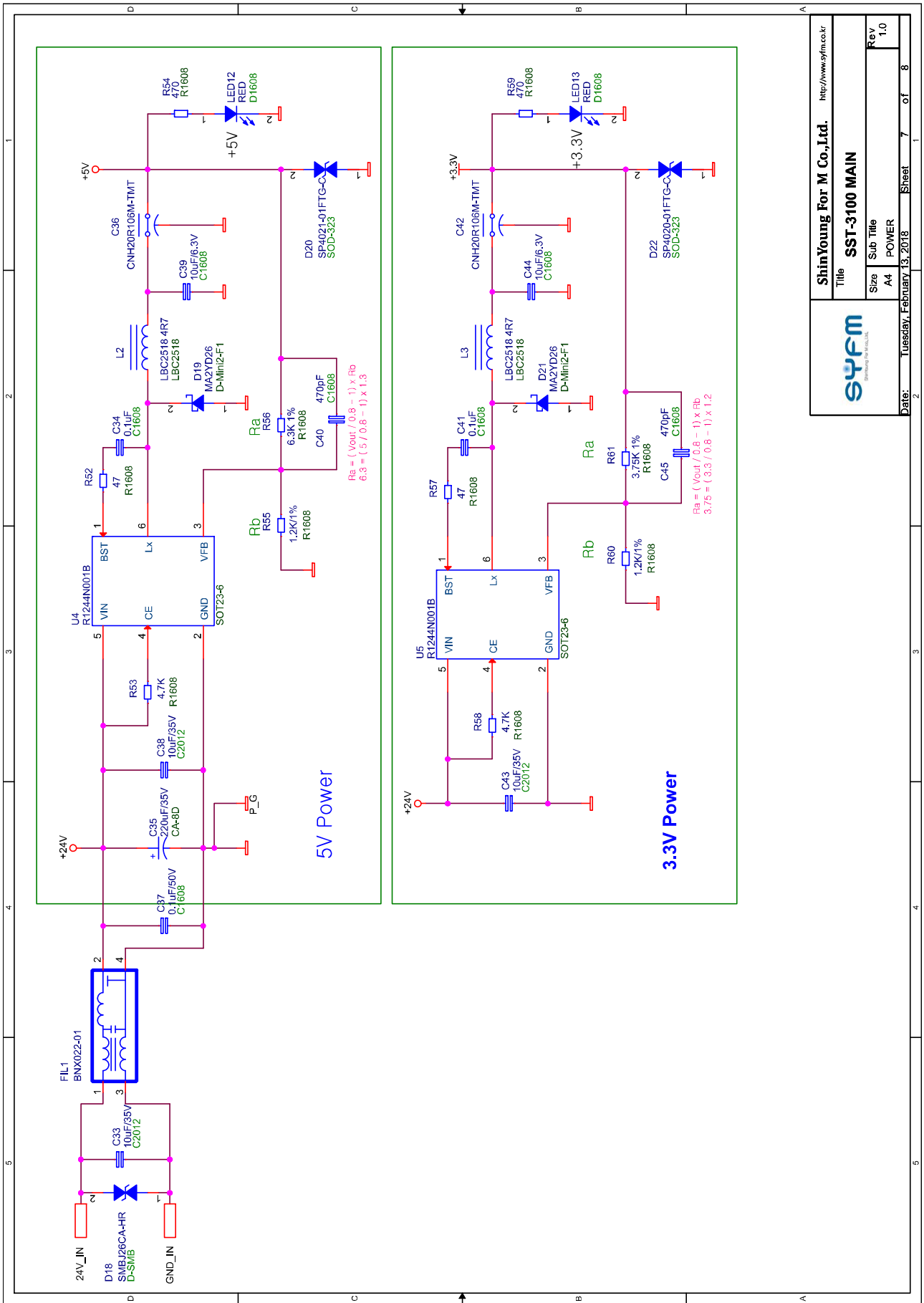

		Title SST-3100 MAIN	
		Size A4	Sub Title POWER
Date: Tuesday, February 13, 2018	Sheet 7 of 8	Rev 1.0	

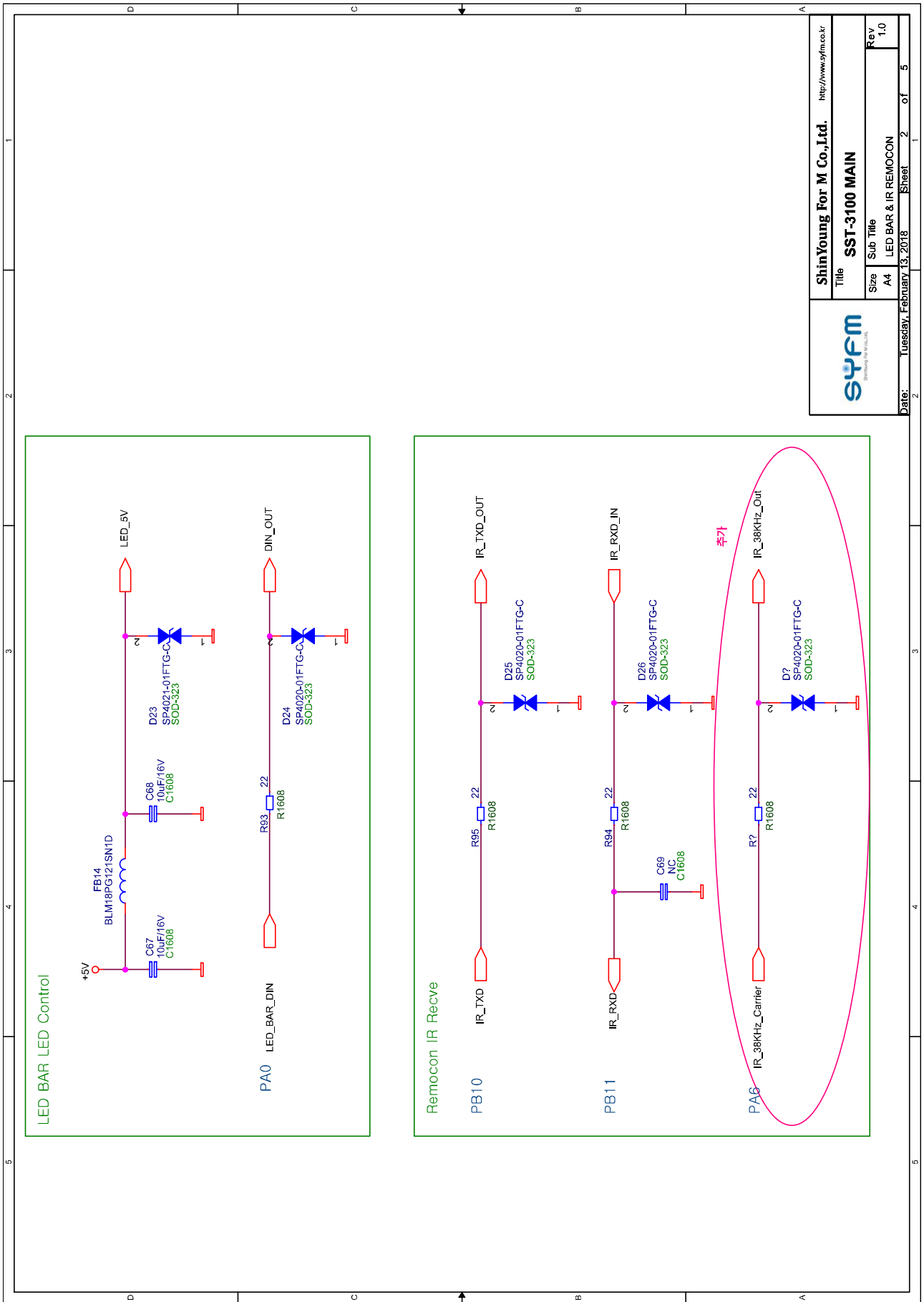

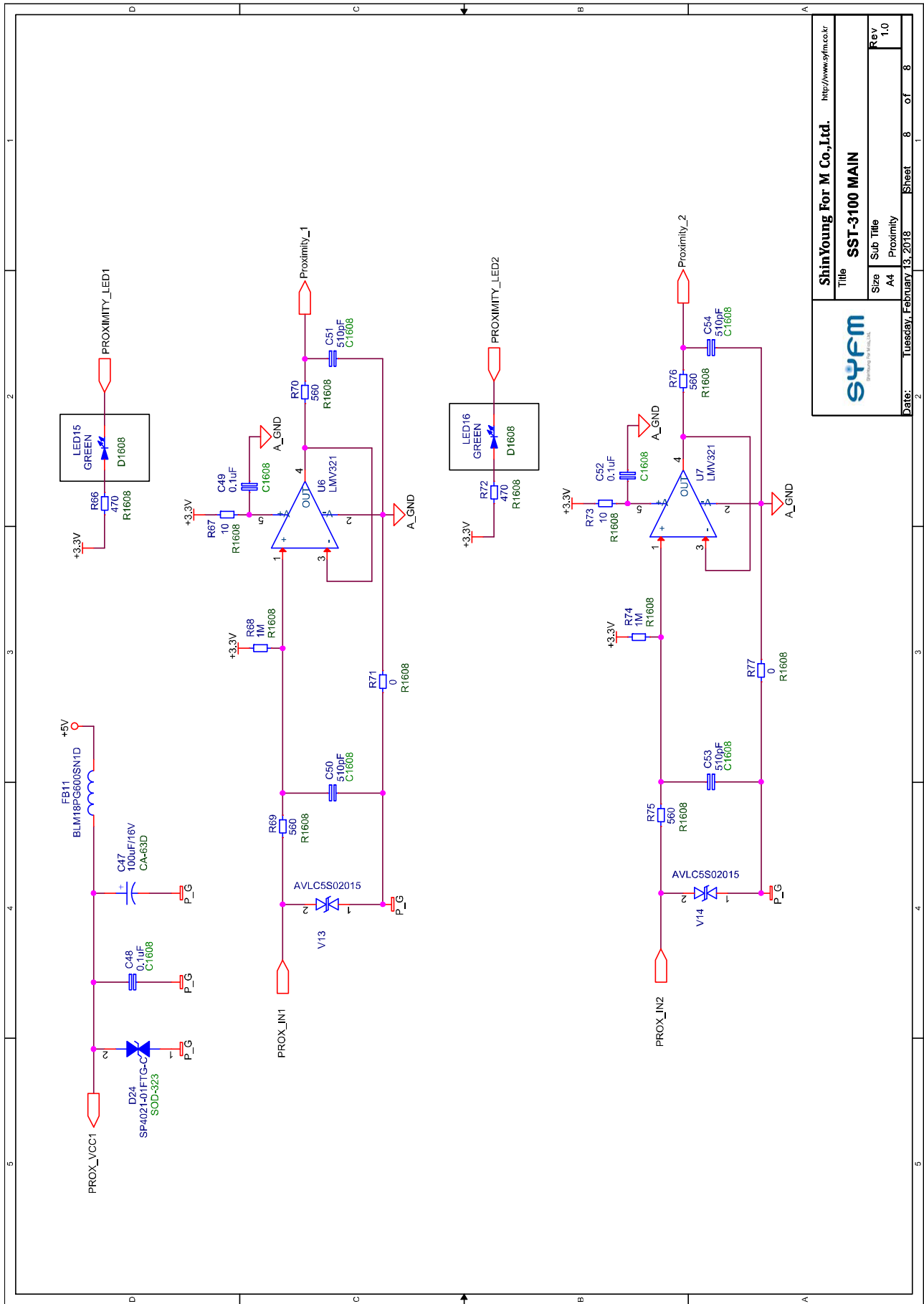

		ShinYoung For M Co.,Ltd. http://www.syfm.co.kr	
		Title SST-3100 MAIN	
Size A4	Sub Title LED BAR & IR REMOCON	Sheet 2	of 5
Date: Tuesday, February 13, 2018		Rev 1.0	

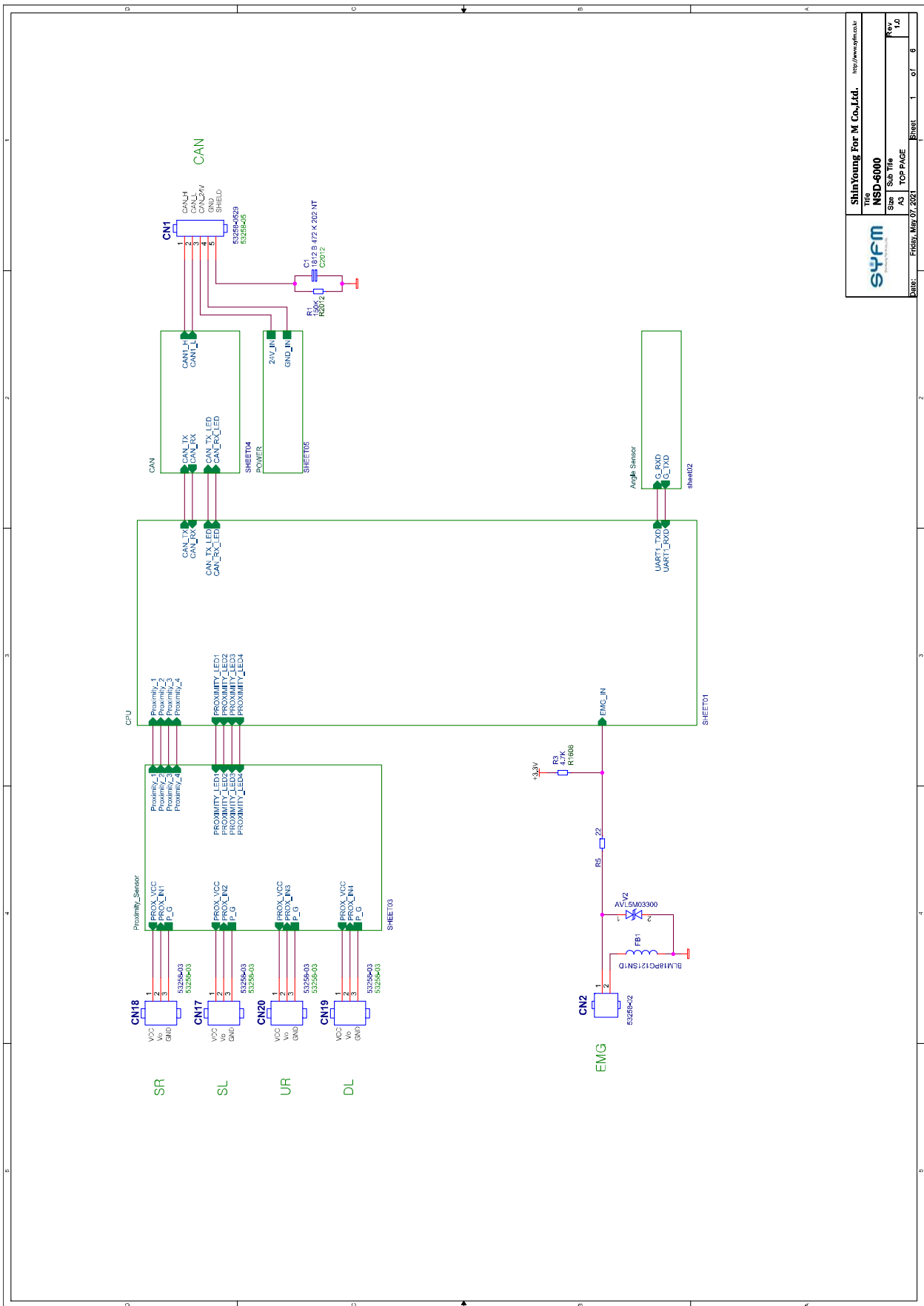

		Title SST-3100 MAIN	
		Sub Title Proximity	
Date: Tuesday, February 13, 2018		Sheet 8	of 8
Size A4	Rev 1.0		

7.3.3 Sensor Board



		ShinYoung For M Co.,Ltd. http://www.syfm.co.kr The NSD-6000 Size: 300x150mm Date: 2021.07.20 TOP PAGE
FIGURE:	FIGURE: 7.3.3	Sheet: 1 of 6

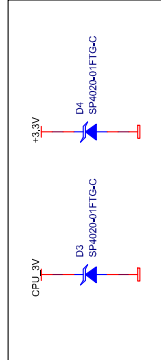
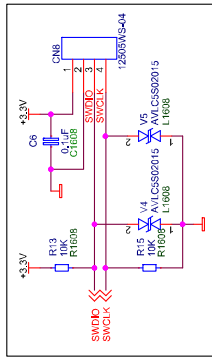
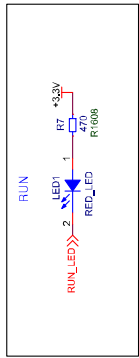
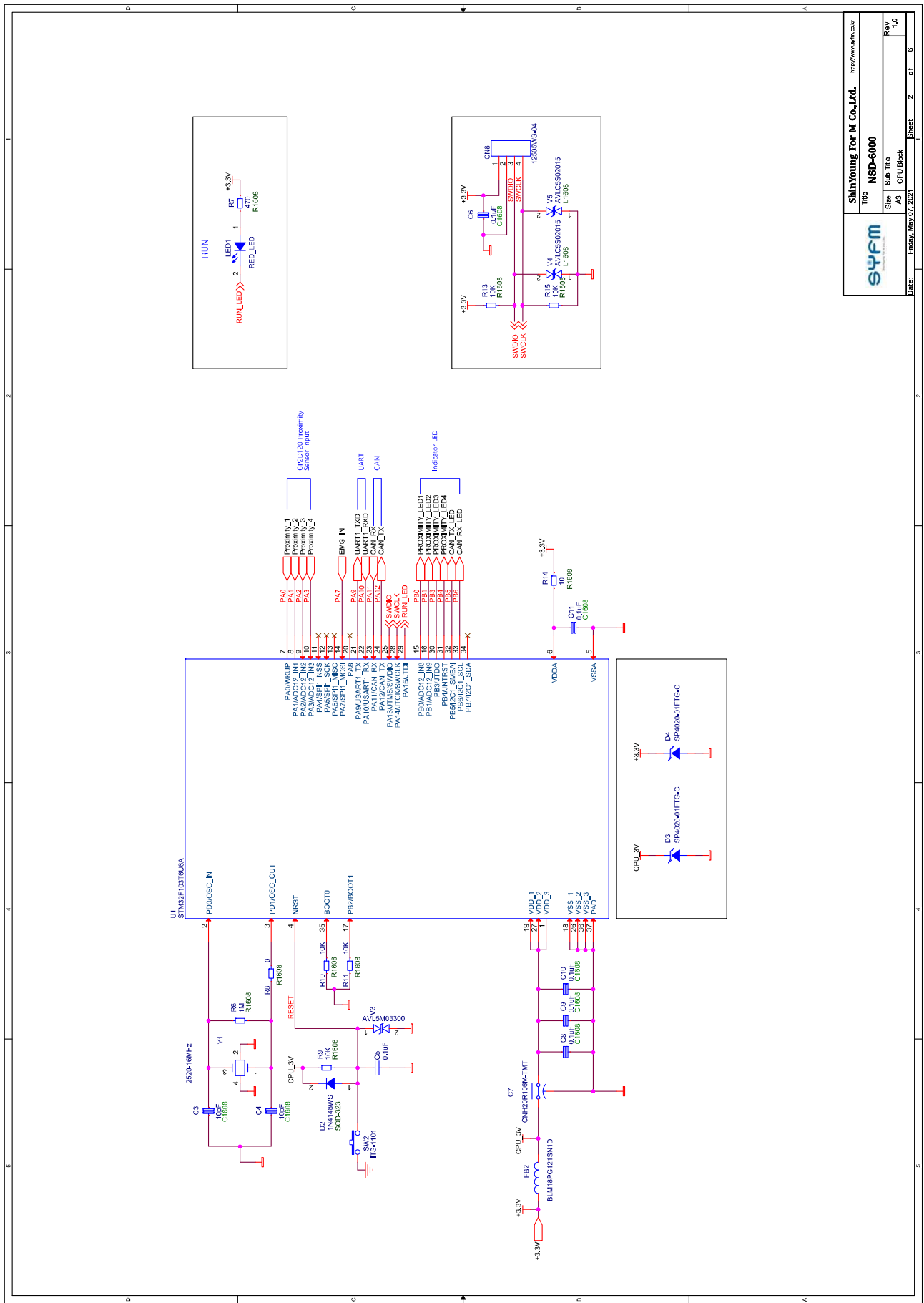

ShinYoung For M Co., Ltd.		http://www.syf.com	
Title		NSD-6000	
Size	Sub Title	CPU Block	Rev. 1.0
Date:	Friday, May 07, 2021	Sheet:	2 of 6

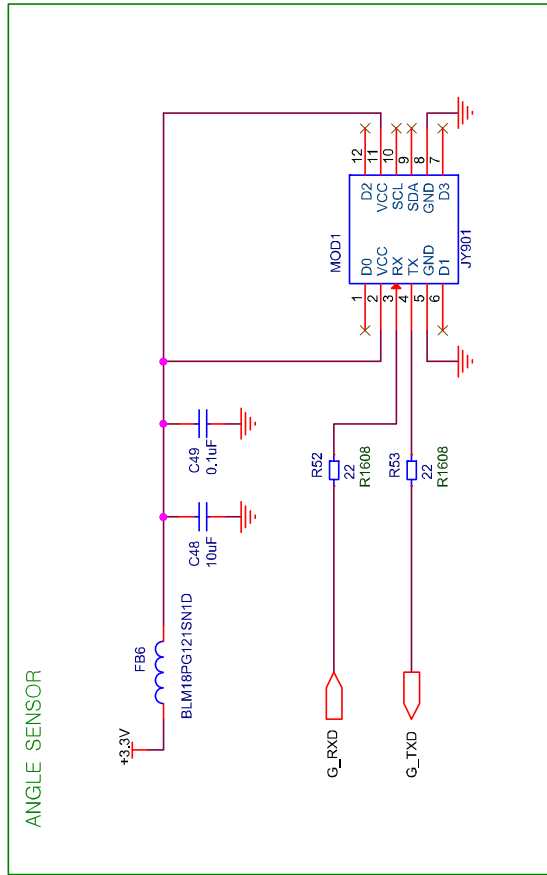

		ShinYoung For M Co.,Ltd. http://www.syfm.co.kr	
		Title NSD-6000	Sheet 3 of 6
Date: Friday, May 07, 2021	Size A4	Sub Title Angle Sensor	Rev 1.0

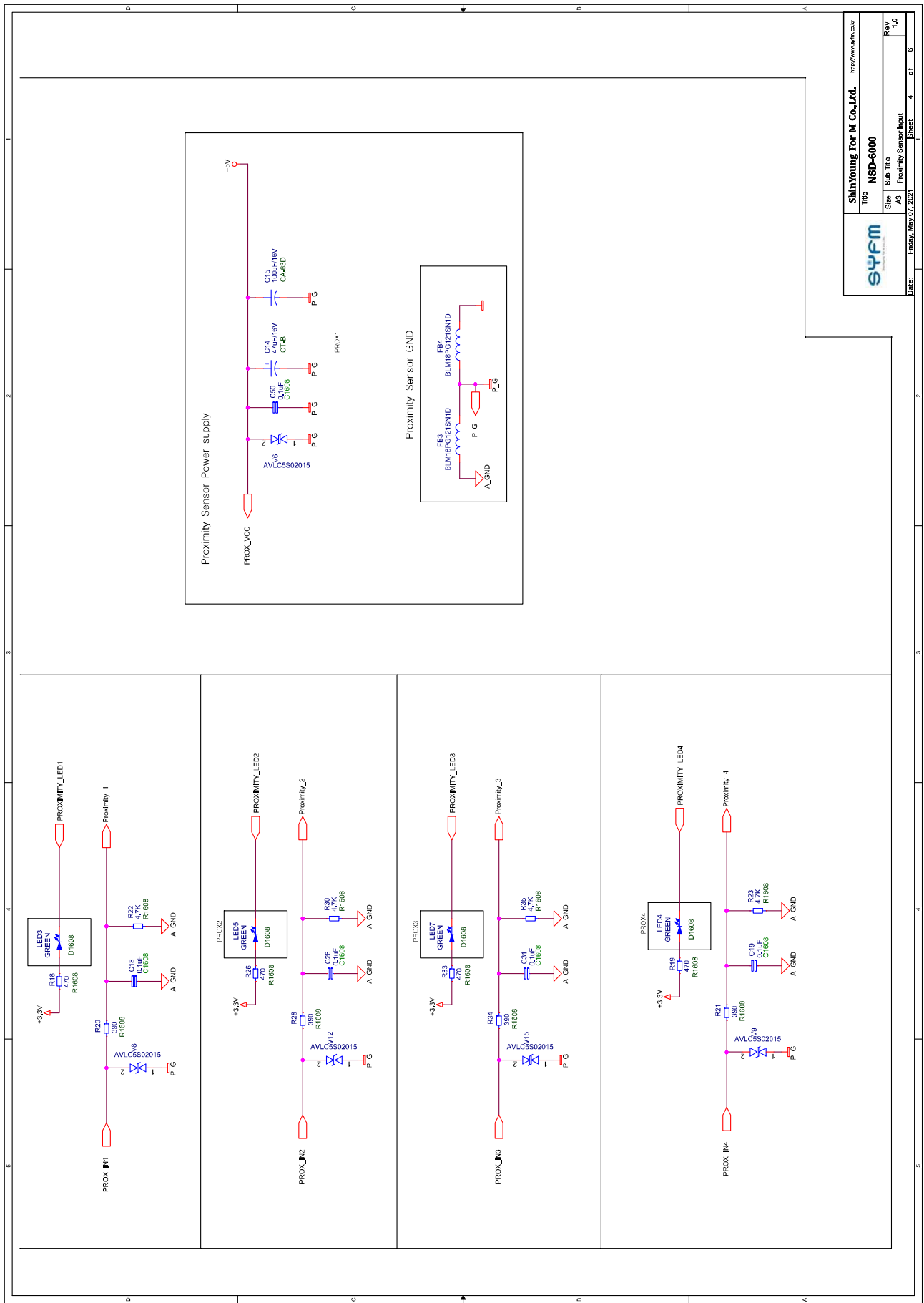

SYFM
SIN YOUNG FOR M CO., LTD.

NSD-6000

Title: NSD-6000
Size: A3
Sub Title: Proximity Sensor Input

Date: Friday, May 07, 2021

Page: 4 of 6

Rev: 1.10

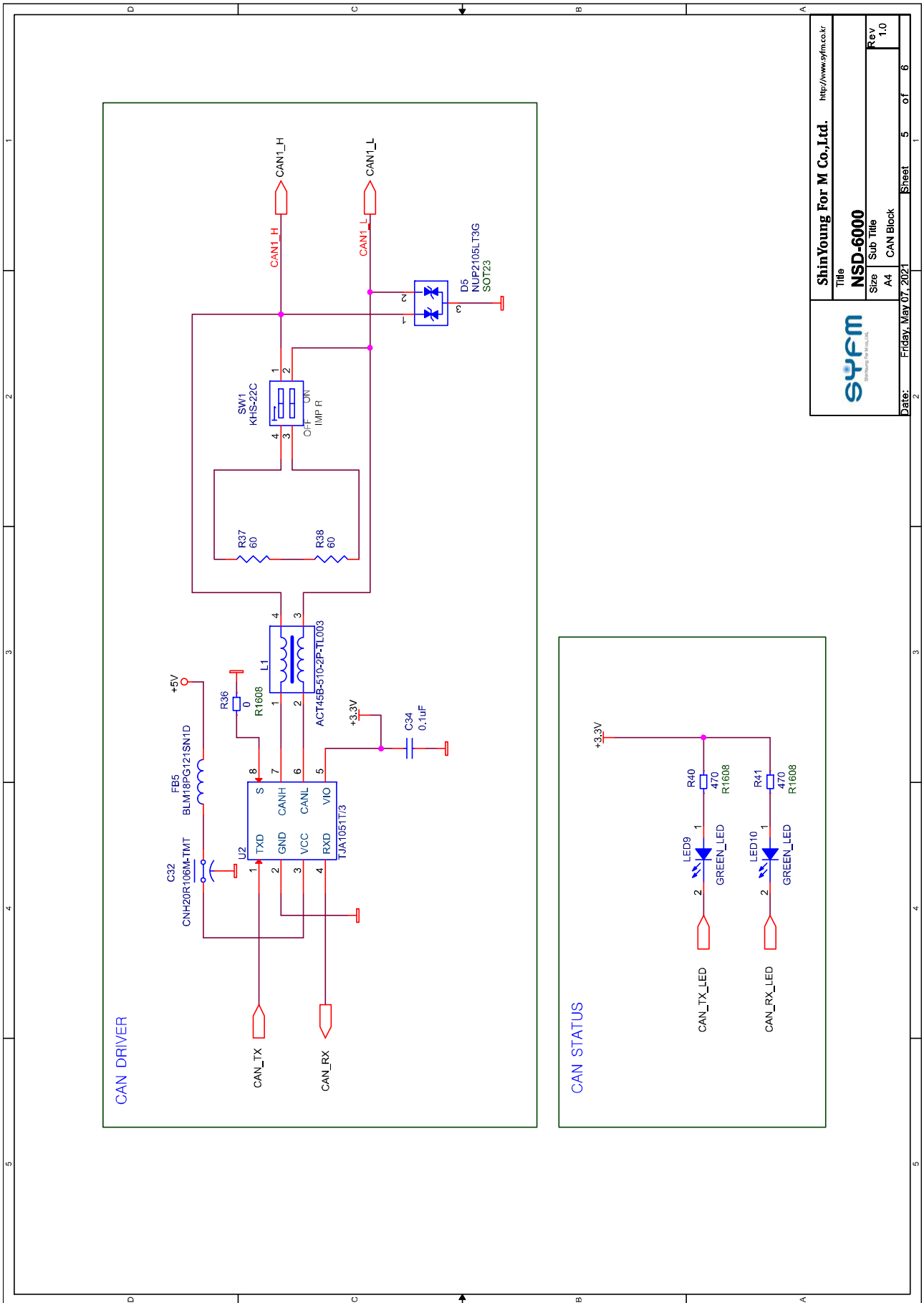

SYFM ShinYoung For M Co., Ltd.		http://www.syfm.co.kr	
Title NSD-6000			
Sub Title			
Size	A4	CAN Block	Rev 1.0
Date:	Friday, May 07, 2021	Sheet	5 of 6

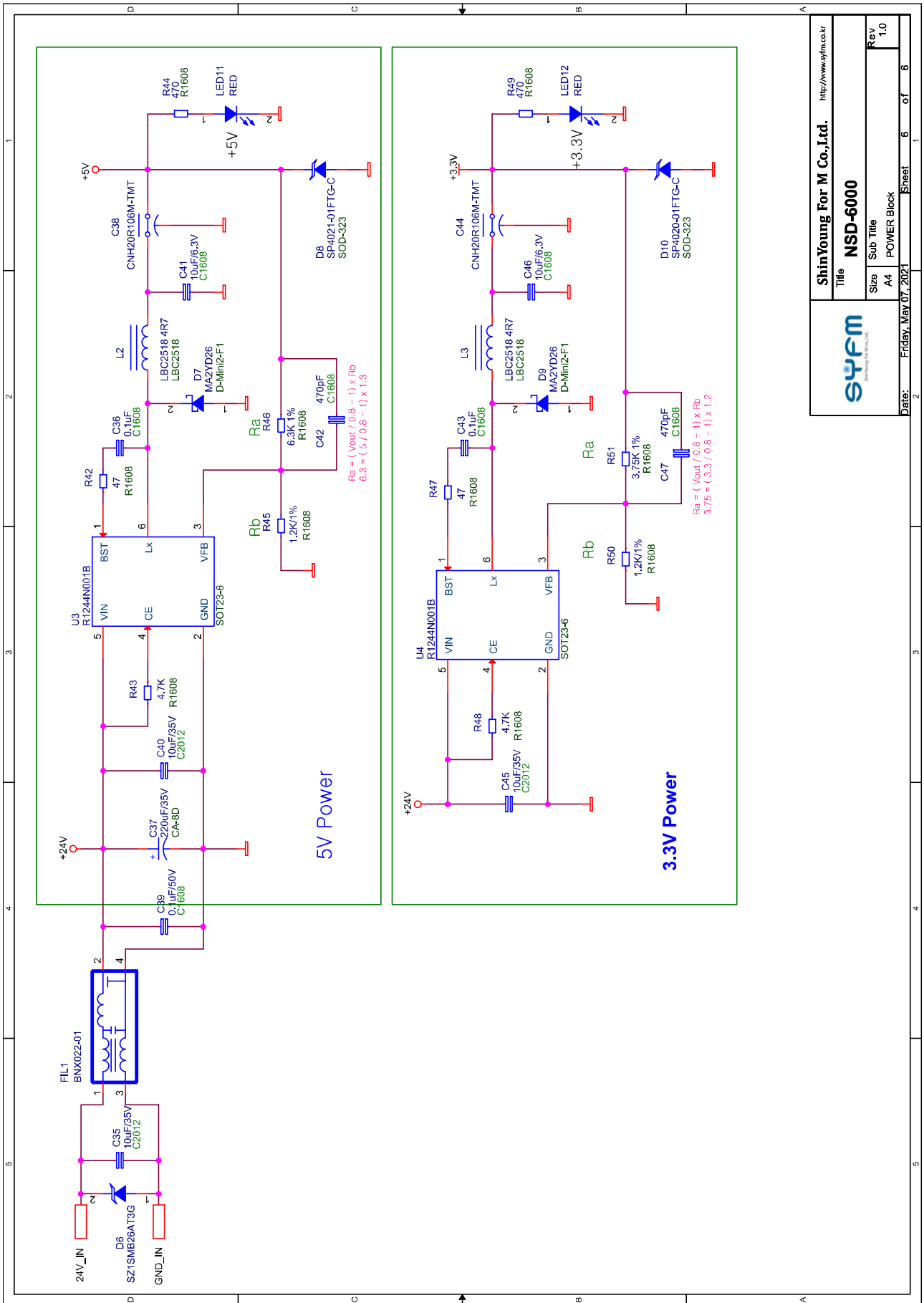

		Title NSD-6000	
		Size A4	Sub Title POWER Block
Date: Friday, May 07, 2021	Sheet 6 of 6	Rev 1.0	

7.3.4 Encoder

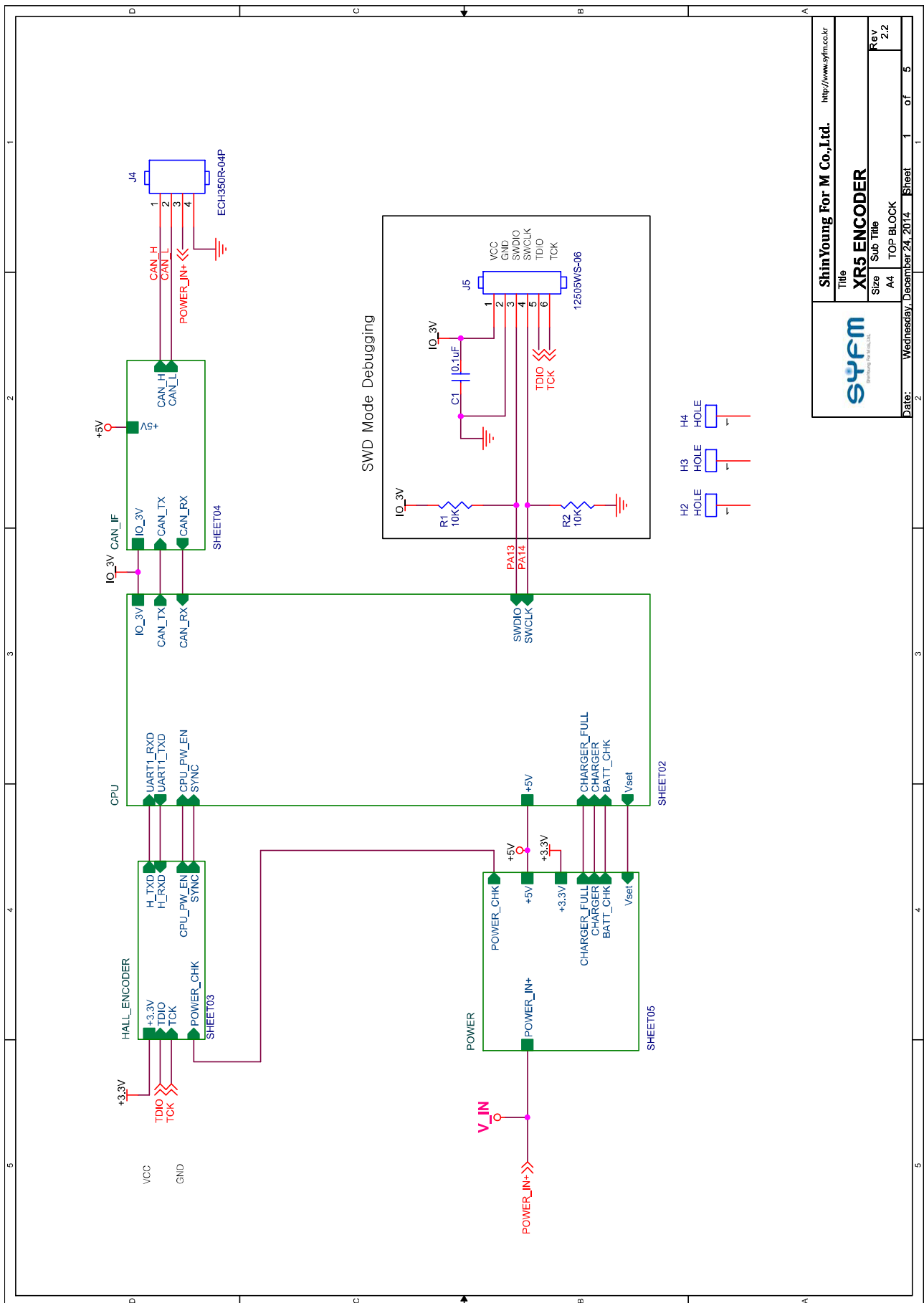

ShinYoung For M Co.,Ltd. http://www.syfm.co.kr	
Title	XRS5 ENCODER
Size	A4
Sub Title	TOP-BLOCK
Rev	2.2
Date:	Wednesday, December 24, 2014
Sheet	1 of 5

http://www.alldatasheet.co.kr/datasheet1~pdf/pdf_kor/617660/111/MSP430FR5722.html

HALL Encoder Chip

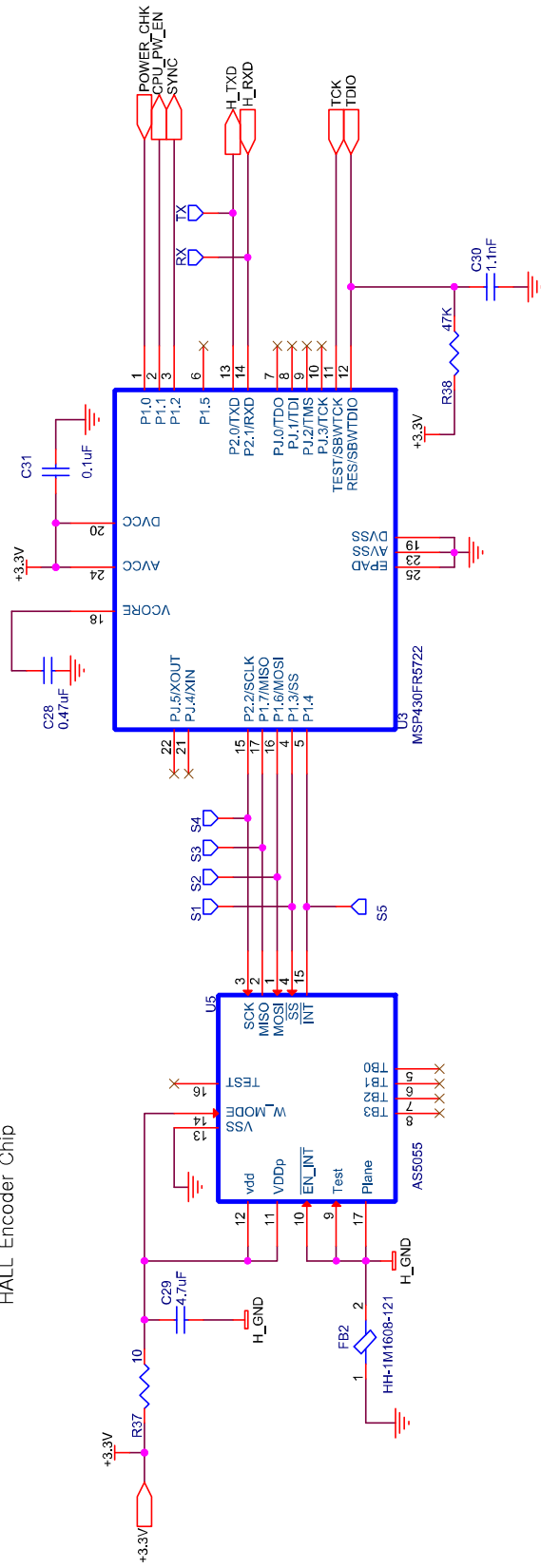

		Title XR5 ENCODER	
		Sub Title HALL ENCODER	
Date: Wednesday, December 24, 2014		Sheet 3	of 5
http://www.syfm.co.kr		Rev 2.2	

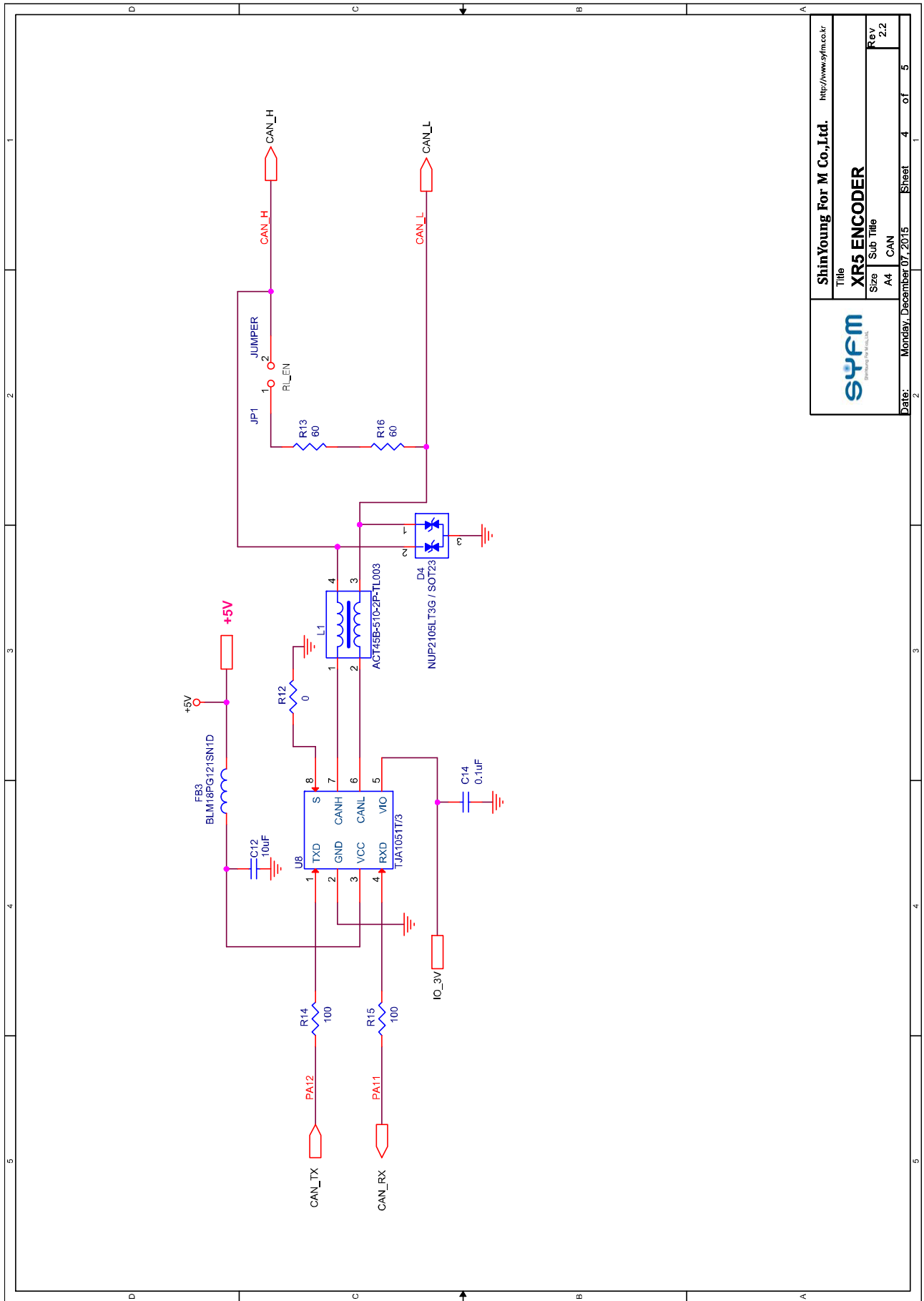

		Title XR5 ENCODER		http://www.syfm.co.kr	
		Size A4	Sub Title CAN	Rev 2.2	Date Monday, December 07, 2015

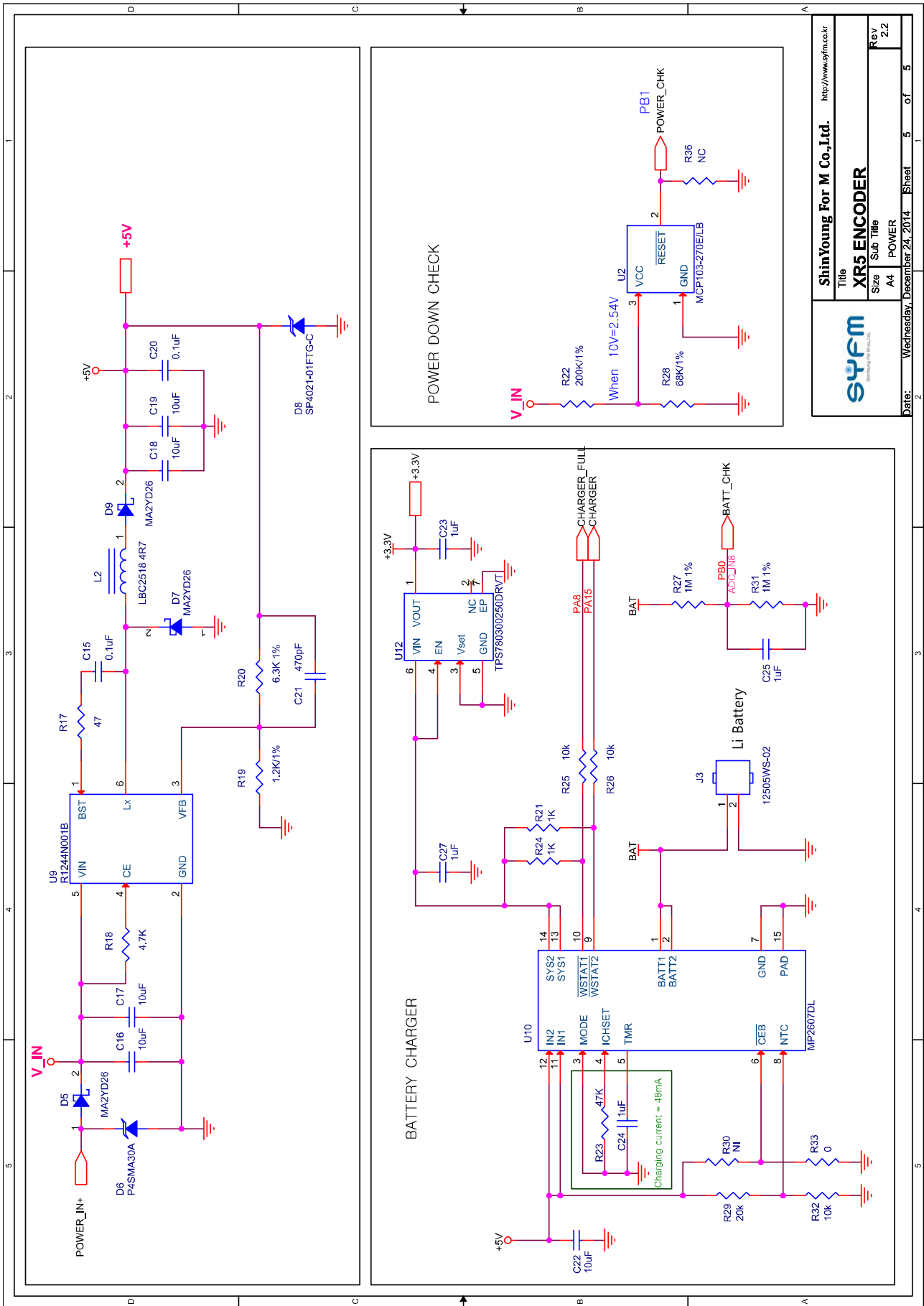



ShinYoung For M Co.,Ltd. <http://www.syfm.co.kr>

SYFM
ShinYoung For M Co., Ltd.

Title	XR5 ENCODER
Sub Title	POWER
Size	A4
Date	Wednesday, December 24, 2014
Sheet	5 of 5
Rev	2.2

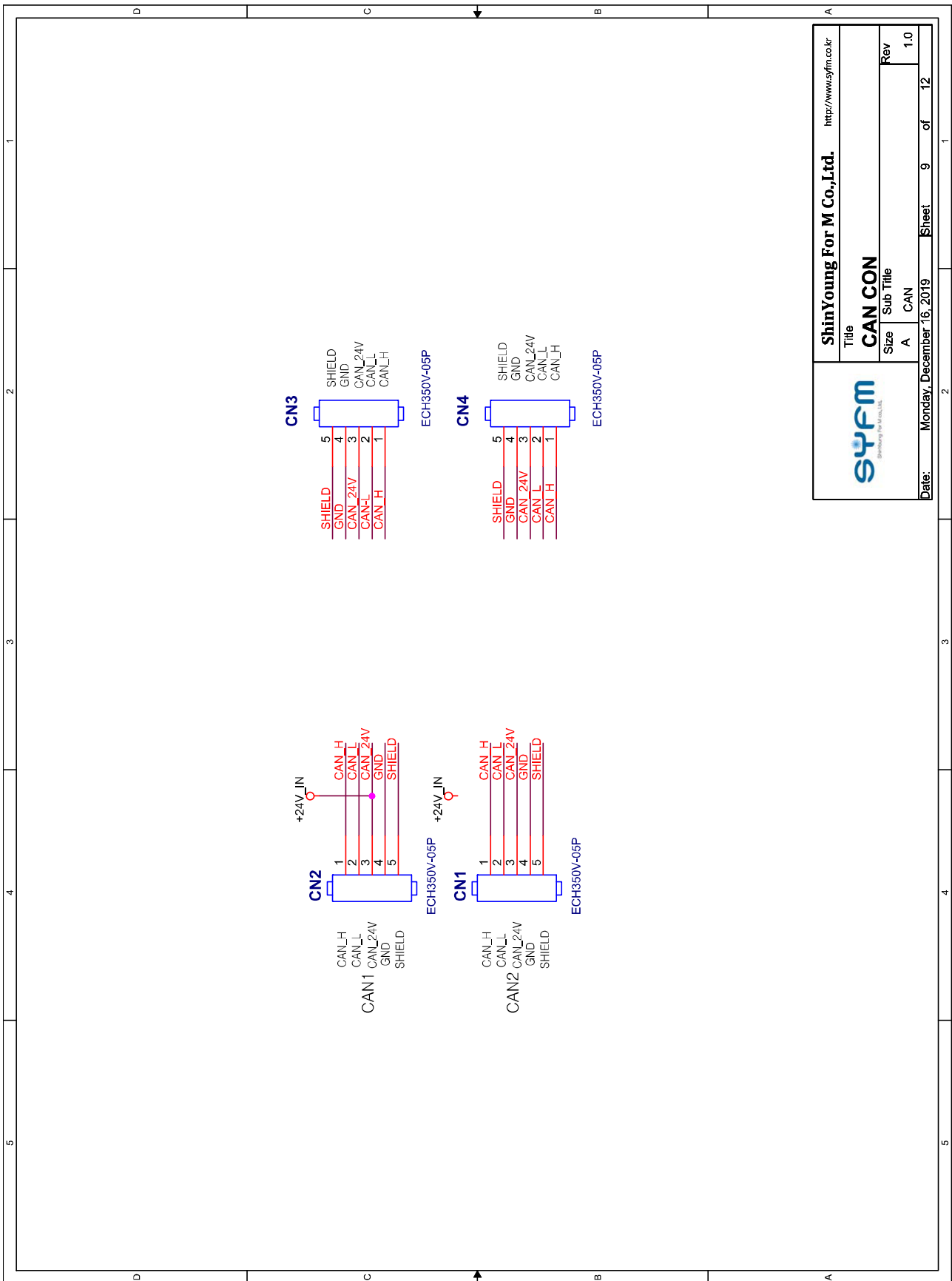
7.3.6 Connector Board



		ShinYoung For M Co.,Ltd. http://www.syfm.co.kr	
		Title: CAN CON	
Sub Title: CAN		Rev: 1.0	
Size: A		Date: Monday, December 16, 2019	
Sheet: 9		of 12	

SHINYOUNG FOR M Co., Ltd.

www.syfm.co.kr

423-1, Jingeononam-ro, Jingeon-eup, Namyangju-si,
Gyeonggi-do, 12129, Korea

TEL: +82-2-3423-3057 FAX: +82-31-573-3059

