

# Quick Start Guide

## M200

### Standard

### Ceiling Suspension

### 08729-001 Rev. A



This quick start guide is not intended as a replacement for the service manual

It is the installer's responsibility to review the service manual **PRIOR** to using this quick start guide

## 1.2 CEILING SUSPENSION AXES AND TRAVELS

Illustration 1-1  
Ceiling Suspension Axes and Travels

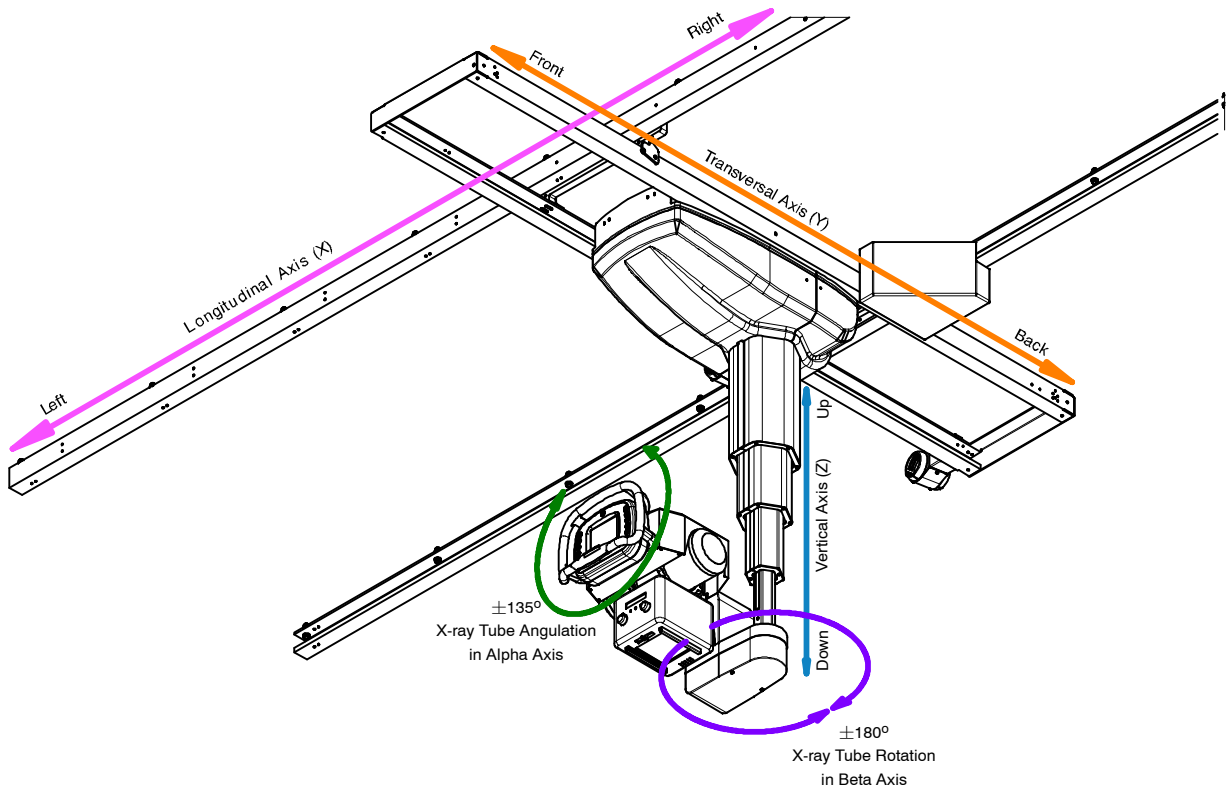

The Ceiling Suspension can be moved manually in the Longitudinal (referred as X), Transverse (Y) and Vertical (Z) axes. But there are another two movements called BETA or X-ray tube rotation and ALPHA or X-ray tube angulation. So it can cover almost all volume of the room where it is installed and operate with horizontal and vertical receptors.

It is a Ceiling Suspension with almost complete manual operation in Longitudinal and Transverse axes. But vertical movement is motorized and Servo-controlled. It operates with a motor that expands or contracts the Telescopic Column and carries out blocking functions.

**Note** 

*Motorized movement means that the vertical movement is helped by motor as soon as the user initiates the motion after releasing the Brake and moves up and down the Tube and Collimator Assembly. The speed is calibrated during the installation procedure.*

# SECTION 2      INSTALLATION

## 2.1      SUSPENSION INSTALLATION PROCEDURE

Mechanical Installation tasks are designed to be performed in sequence.

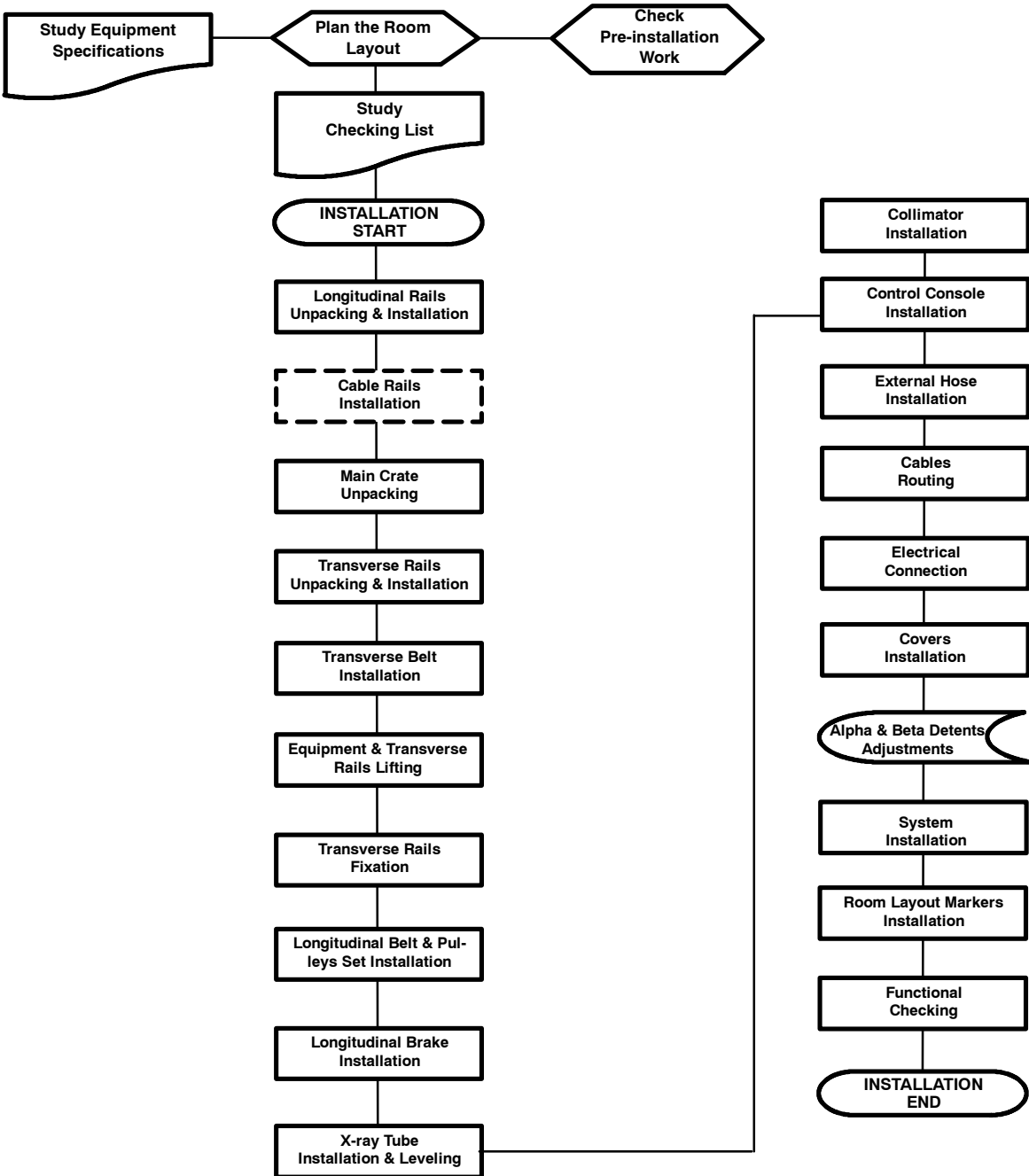

## 2.2 LONGITUDINAL RAILS UNPACKING AND INSTALLATION

### REQUIRED ELEMENTS

BOX	P/N	DESCRIPTION	QTY.
N/A	Variable depending on the length	Longitudinal rail with Brake plate	1
	Variable depending on the length	Longitudinal rail	1
	00574P01	Bumper * (For rail end stops)	2
	S0017044	Bumper Support * (For rail end stops)	1
	S0017043	Bumper Support * (For rail end stops)	1
	S0004605	Slotted Cheese Head Screw M5x20 * (For rail end stops)	4
1	07696P01	Leveling Shim 1 mm.	30
	07696P02	Leveling Shim 2 mm.	25
	07696P03	Leveling Shim 3 mm.	20
	51202P33	Screw M12x50 AOCL 8.8	24
	51380P31	Washer M12	48
	51350P15	Nut EX M12	24

**Note** 

*Rail End stop bumpers are shipped already assembled and mounted on rails.*

**Illustration 2-1**  
**Longitudinal Rails required Elements**

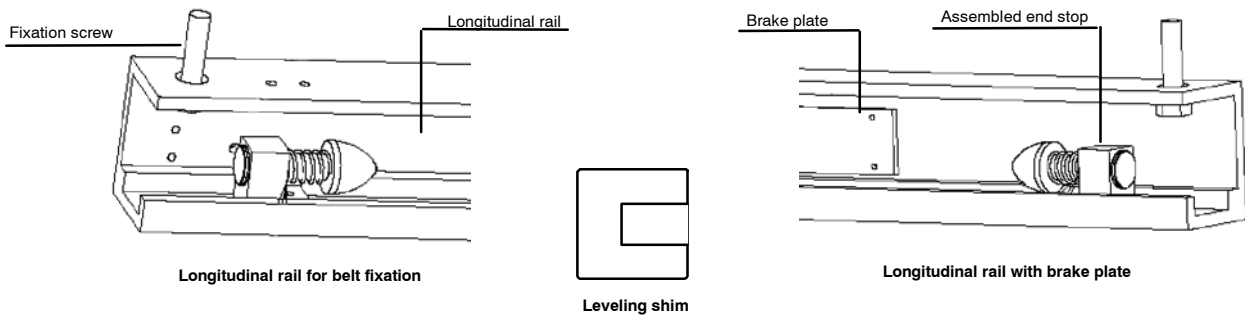

## PROCEDURE

1. Move the rails shipping container to the installation area and leave it in horizontal position just down where the rails are to be installed definitely.
2. Open the crate, loosen all the screws of the top cover.
3. Move away all shipping material, but do not remove the plastic bag or any other shipping material until checking completely the equipment proper status and that all elements have been received.
4. Locate the frontal and back Longitudinal rails in their correct position.
  - The front rail has the brake plate assembled, to work with the brake.
  - The back one does not have any brake installed. There will be installed the Longitudinal belt.

**Illustration 2-2**  
**Fix Longitudinal Rails to Ceiling**



5. Install first the front rail by tightening totally the fixing screws, the frontal rails goes always nearest to the operator position. It is recommended to tighten first both extreme screws, and then all intermediate screws.

**Note** 

*It is recommendable to use the in optional Installation Kit, P/N A11160-01. In case of use any other tool, it must comply with all the ceiling, installation and safety requirements.*

6. Use to fix all the Longitudinal Rails, all of them are in Packing Box 1.
  - 51202P33 SCREW M12 X 50 AOCL 8.8
  - 51380P31 WASHERS
  - 51350P15 NUTS

7. **Make sure that the rail is properly level.** Use the digital Level. The maximum tolerance must be  $0.1^\circ$ . If rails are not properly level, check that all screws are tightened totally; but it may be also because the Ceiling is not level. Use a Laser Alignment Tool or Digital Level to check the Rails leveling.

**Illustration 2-3**  
**Check Rails Leveling**

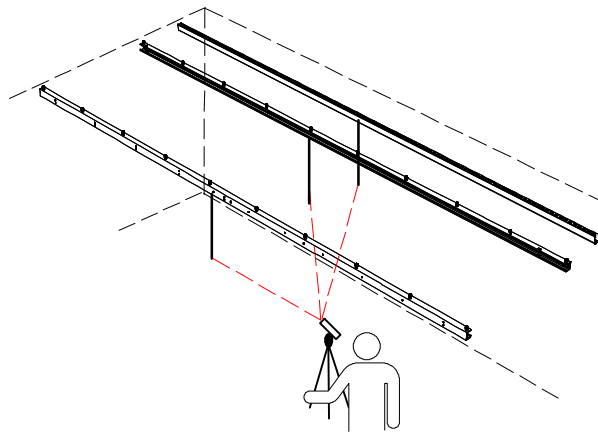

8. Use the leveling shims to get the proper balance and horizontality. Mount the shims between Longitudinal rails and ceiling or alphen rail, if used, and fixed by the rail fixing screws.

**Illustration 2-4**  
**Use the Leveling Shims to get Rails level**

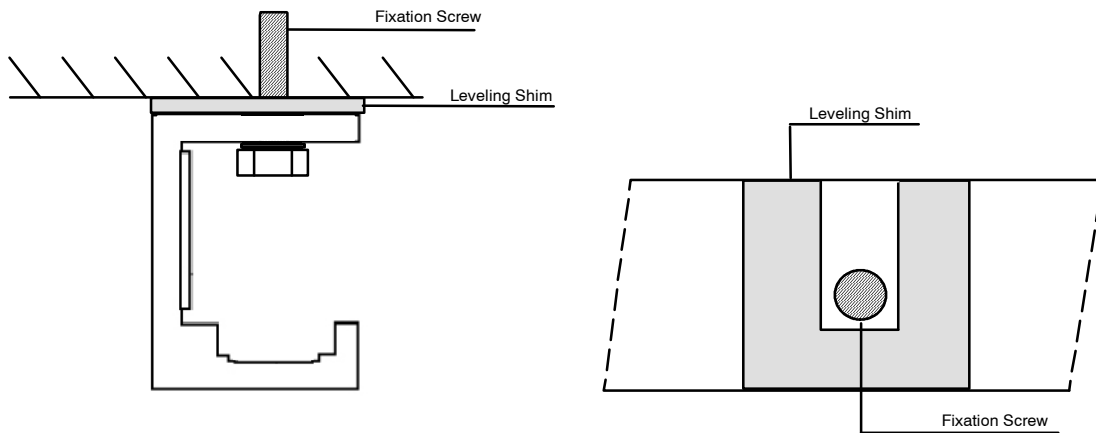

9. Install the back Rail. Make sure that the distance between both rails external sides is 1495 mm  $\pm$  15 mm in all points. Check in different points (between holes center), if the distance is always the same one.



**MAKE SURE THAT ALL FIXATION SCREWS ARE WELL TIGHTENED AND FIXED, AND THAT RAILS ARE LEVEL AND PARALLEL. IN CASE THAT THE RAILS ARE NOT PROPERLY INSTALLED AND LEVEL THE EQUIPMENT WILL NOT OPERATE PROPERLY.**

**Illustration 2-5**  
**Recommended Distance between both Longitudinal Rails**

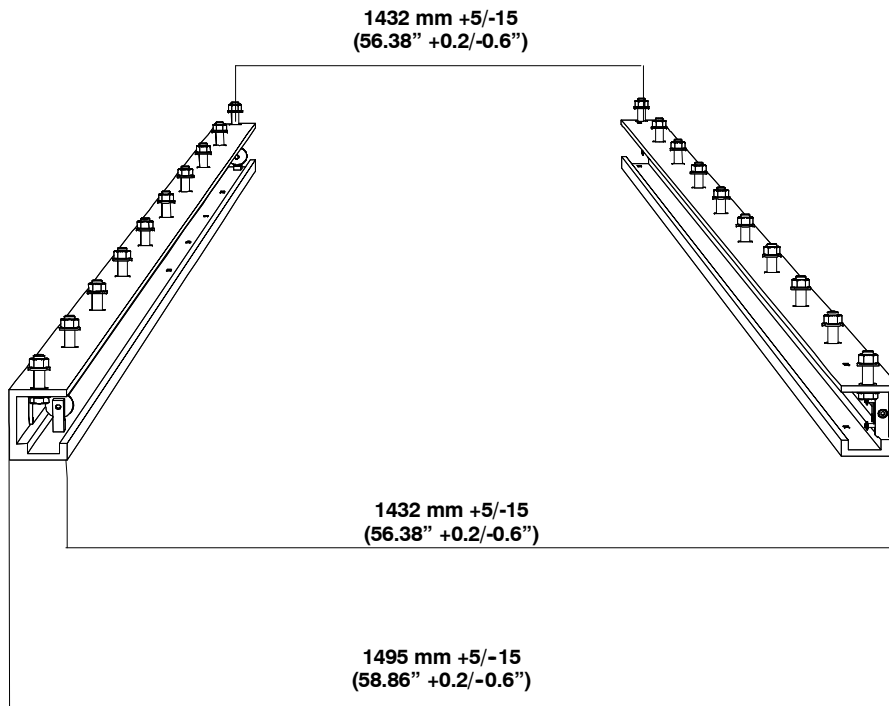

## 2.3 LONGITUDINAL TRAVEL MODIFICATION (OPTIONAL)

Proceed to complete this optional procedure when desired to increase the Longitudinal displacement of the Suspension, specially when working in Single Panel Systems. With this change the Longitudinal displacement can be 300 mm (11.81") longer.

To increase the Longitudinal travel, proceed to change the position of the End Stop located at the right of the front Longitudinal Rail.

**Illustration 2-6**  
**Auto-tracking Ceiling Suspension Longitudinal and Transverse Movement**

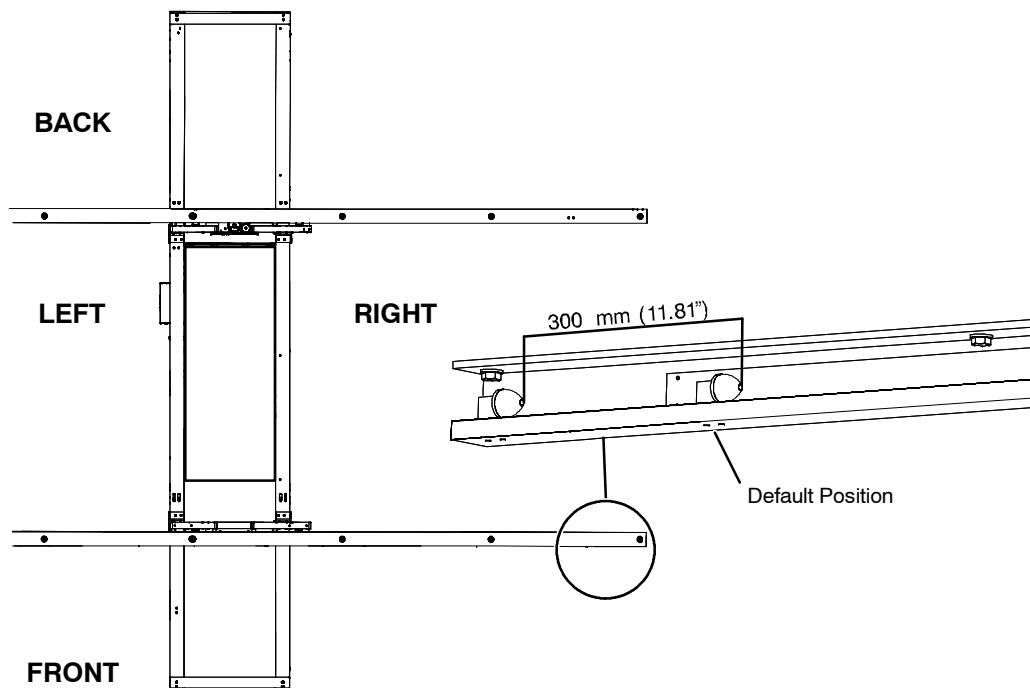

Loosen both fixation screws of the End Stop and install the End Stop in the position at the end of the rail, use the drill holes located at 45 and 25 mm (1.77" and 0.98") from the end of the Rail.

## 2.4 CABLES RAIL INSTALLATION

**Note** 

*Cables rails are optional. In case of use any different Cable Rail, it is absolutely mandatory that it complies with all the ceiling, installation and safety requirements. Refer to the Pre-installation Manual for further details.*

### REQUIRED ELEMENTS

BOX	P/N	DESCRIPTION	QTY.
n/a	51202P33	Screw M12 x 50 AOCL 8,8	10
	51380P31	Washer M12	20
	51350P15	Nut Ex M12	10
n/a	S0022010	Cable Rail Tube Hose	1
	S0019737	Cable Rail Velcro Hose	1
	S0019739	Unistrut Carriage	1
	S0019740	Brace/Case/Washer	1
	S0019741	Threaded Hook	1
n/a	S0019972	Spring Nut M6	2
	S0020454	Nut Fixation	2
	51212P67	Socket Cap Screw Din912 M6 X 20	2
	51390P12	Aet Washer 6	2

**Note** 

*There are two different Cable rails depending on the type of hose, if it is Velcro covered or tubular, they are provided with different Hose sliding fixation kit. Installation procedure is the same for both Cable Rails.*

#### Illustration 2-7 Cable rail and fixation screws



**Hose Fixation Kit**

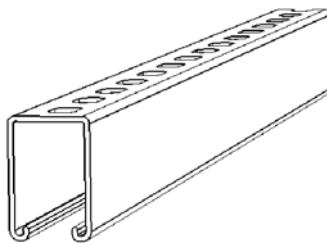

**Cable Rail**



**Rail Fixation Screws**

## PROCEDURE

1. Install the Cable Rail at the back of the room. It is recommended to begin tightening the rails end screws, and then all intermediate screws.
2. Open Packing Box 2 of the Rails Crate.
3. Fix the Cable Rail, use:
  - 51202P33 SCREWS M12X50 AOCL 8,8
  - 51350P15 NUTS EX M12
  - 51380P31 FLAT WASHER B13 A0

**Illustration 2-8**  
**Cable Rail Fixation**



4. Install the three Hose Fixation Kits.
  - S0019737 HOSE SLIDING FIXATION for Velcro Hose or  
S0022010 Longitudinal SLIDING FIXATION for Tubular
  - S0019739 UNISTRUT CARRIAGE
  - S0019740 BRACE/CASE/WASHER
  - S0019741 THREADED HOOK

**Illustration 2-9**  
**Hose Fixation Kits**



5. Install the Spring Nut Assembly, P/N S0019972, at the ends of the Cable Rails.
  - S0019972 SPRING NUT M6
  - S0020454 NUT FIXATION
  - 51212P67 SOCKET CAP SCREW DIN912 M6 X 20
  - 51390P12 AET WASHER 6

**Illustration 2-10**  
**Spring Nut Assembly**



6. Check that all screws are properly fixed.
7. Check that the distance of the Cable rail to the rear wall is the minimum required or higher. Refer to *Section 1.5 Pre-installation Checks & Equipment Specifications*.

**Illustration 2-11**  
**Minimum Distance Cable Rail to Wall**

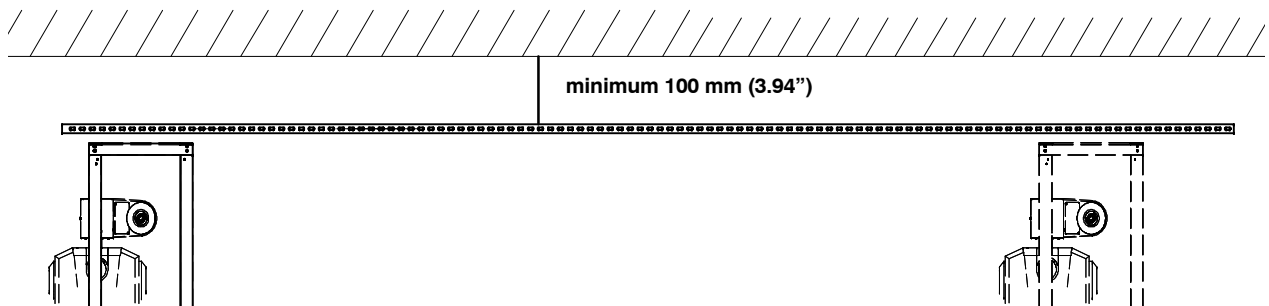

## 2.5 TRANSVERSE RAILS AND MAIN ASSEMBLY INSTALLATION

### REQUIRED ELEMENTS

BOX	P/N	DESCRIPTION	QTY.
N/A	Variable depending on the length	Transverse Rail with Brake Plate	1
	Variable depending on the length	Transverse Rail	1
	00574P01	Bumper * (For Rail End stops)	2
	S0006442	Bumper Support * (For rail end stops)	2
	S0004599	Slotted Cheese Head Screw M5x20 * (For rail end stops)	4
	S0021351	End Covers Transverse Rail	2
	--	Telescopic Column	1
3	S0004605	Screw M5x20 ISO7380	6
	51383P30	Big Washer M5	6
	51361P03	Lock Nut M5	6
	53054P01	Tie Wrap UNEX1201	6
	51212P25	Socket Cap Screw DIN912 M4x12	6
	51380P26	Washer DIN125 M4	6
	51390P10	AET Washer M4	6

**Note** 

*Rail End stop bumpers are shipped already assembled and mounted on rails.*

**Illustration 2-12**  
**Required Elements**

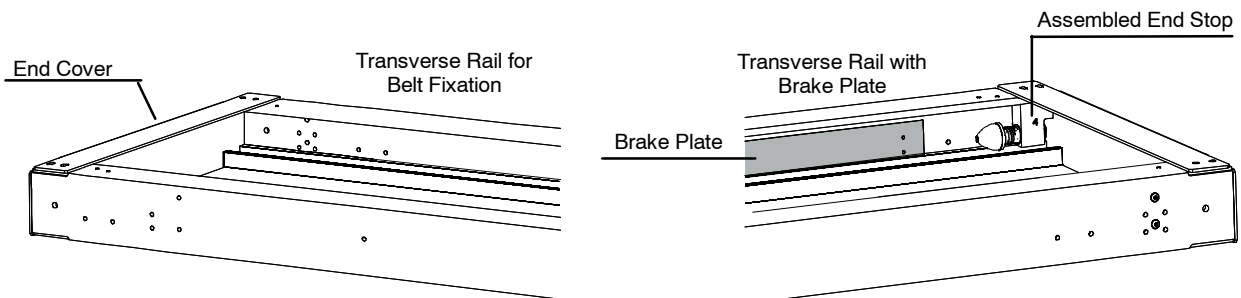

## MAIN CRATE UNPACKING

1. Place the Main Assembly at the center of the already installed longitudinal rails to make easier the lifting procedure. It must be lifted to the ceiling and fixed to the longitudinal rails together with the Main Assembly Support.
2. Remove the upper and all lateral covers of the crate.
3. The Main Assembly is hanged on the Mounting Brackets and Mounting Bridge, and on the Main Assembly Support.
4. Remove all shipping materials and all Suspension elements as hoses, bearings, etc. Keep on the pallet just the Main Assembly Support with the Main Assembly and Mounting Brackets and Bridge.

**Illustration 2-13**  
**Main Assembly without Shipping Bags and Boxes**

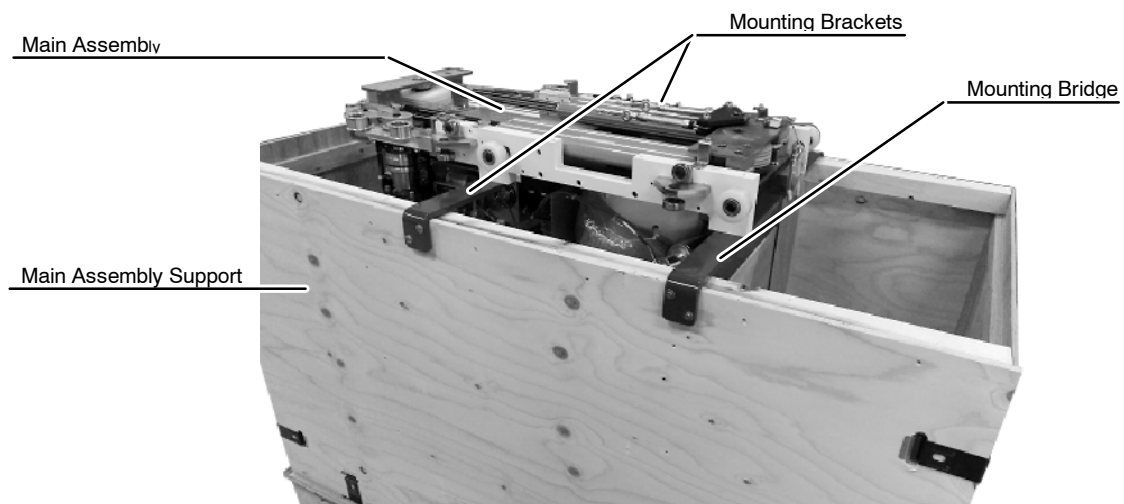

**DO NOT LOOSEN THE MOUNTING BRACKETS AND THE MOUNTING BRIDGE YET. IT IS MANDATORY TO KEEP THE CEILING SUSPENSION FIXED TO THE MAIN ASSEMBLY SUPPORT UNTIL IT IS INSTALLED AND FIXED TO THE LONGITUDINAL RAILS.**

## INSTALLATION PROCEDURE



**WARNING**

PROCEED TO THE INSTALLATION OF THE TRANSVERSE RAILS AS CAREFULLY AS POSSIBLE. MAKE SURE THAT NO ELEMENT OF THE CARRIAGE OF THE SUSPENSION OR THE COLUMN HAS BEEN DAMAGED DURING THIS PROCEDURE.



**WARNING**

MAKE SURE THAT THE CEILING SUSPENSION AND TRANSVERSE RAILS ARE MOUNTED TOTALLY PERPENDICULAR TO THE LONGITUDINAL RAILS.



**WARNING**

MODIFYING BRIDGE LENGTH IS NOT RECOMMENDED. IF MODIFICATION OF THE BRIDGE IS REQUIRED, YOU MUST CHECK WITH YOUR INSTALLATION SPECIALIST. CONFIRM THAT THE LENGTH YOU DESIRE WILL NOT LIMIT YOUR ABILITY TO PURCHASE FUTURE PRODUCT OPTIONS OR UPGRADES (I.E. VOLUME RAD).

### Illustration 2-14

Proceed to mount the Transverse Rails in the next Order

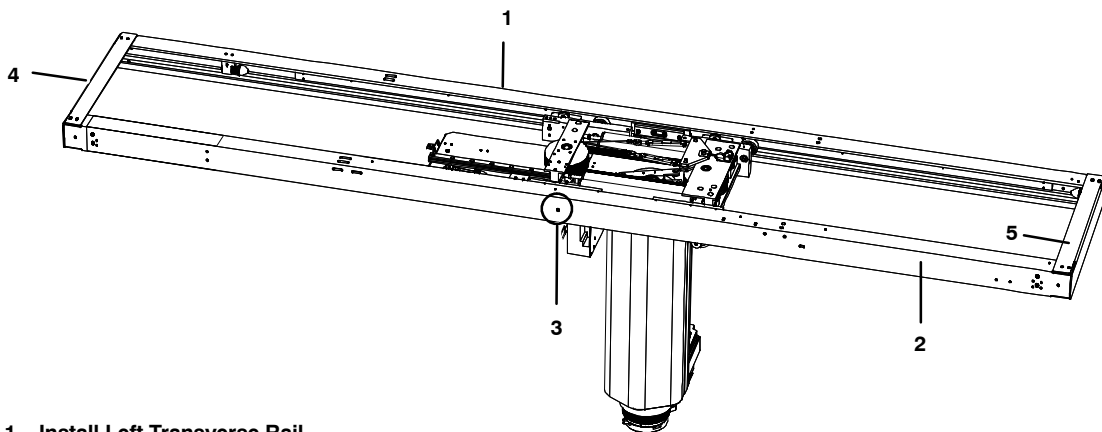

1. Install Left Transverse Rail
2. Install Right Transverse Rail
3. Fix the Rail to the Carriage
4. Install Front End-cover
5. Install Back End-cover

1. Mount the Carriage wheels on the Left Transverse Rail (Brake Plate rail). The wheels must run without obstacles. Just fit the carriage wheels into the Transverse Rail end and roll until locating the Column in the center of the rail.

**Illustration 2-15**

**Mount the Rails on the Bearings Wheels and slide carefully**

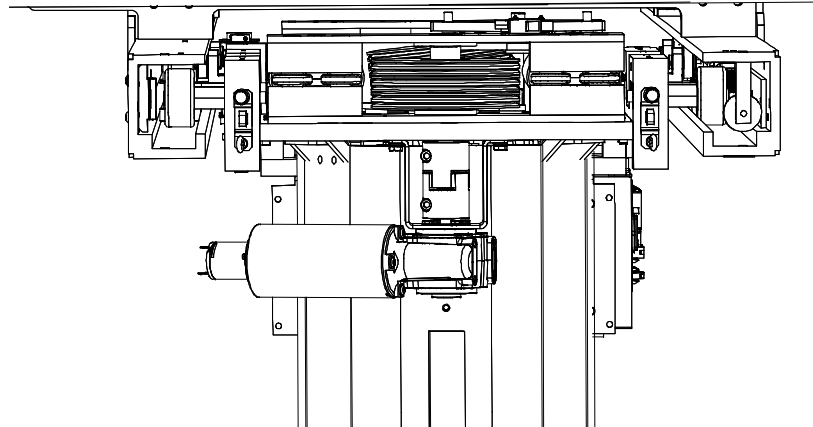

2. Mount the Right Transverse Rail (The one without metal Brake Plate).
3. Fix the rails position with the Fixing Screw. This is highly important to avoid unexpected movements of the Main Assembly along Transverse rails. Insert the Fixing Pin provided with the Suspension, or any other bar, in the lateral hole of the Right Transverse Rail.

**Illustration 2-16**

**Use the pin to fix the Ceiling Suspension**

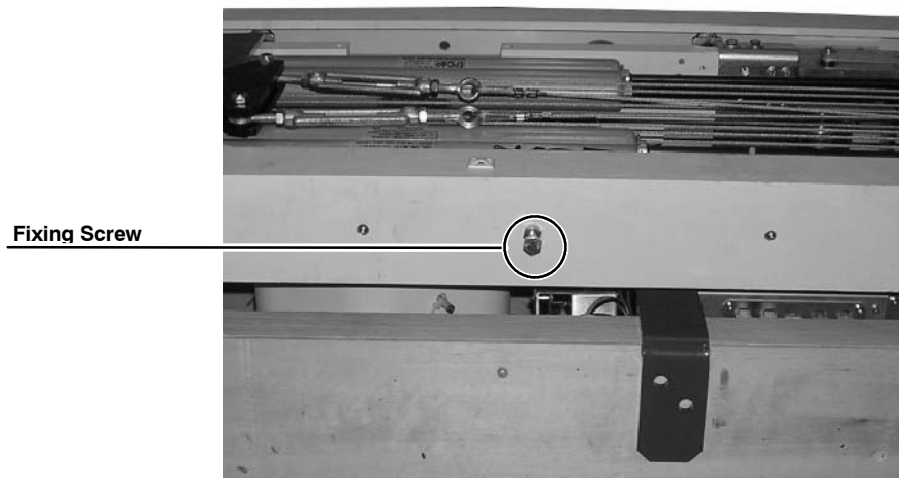

4. Place the End Cover at each Rails end.
5. Open Packing Box 3. Each End Cover is tighten to the rails in two points.

**Illustration 2-17**  
**Transverse Rails End Covers Fixation**

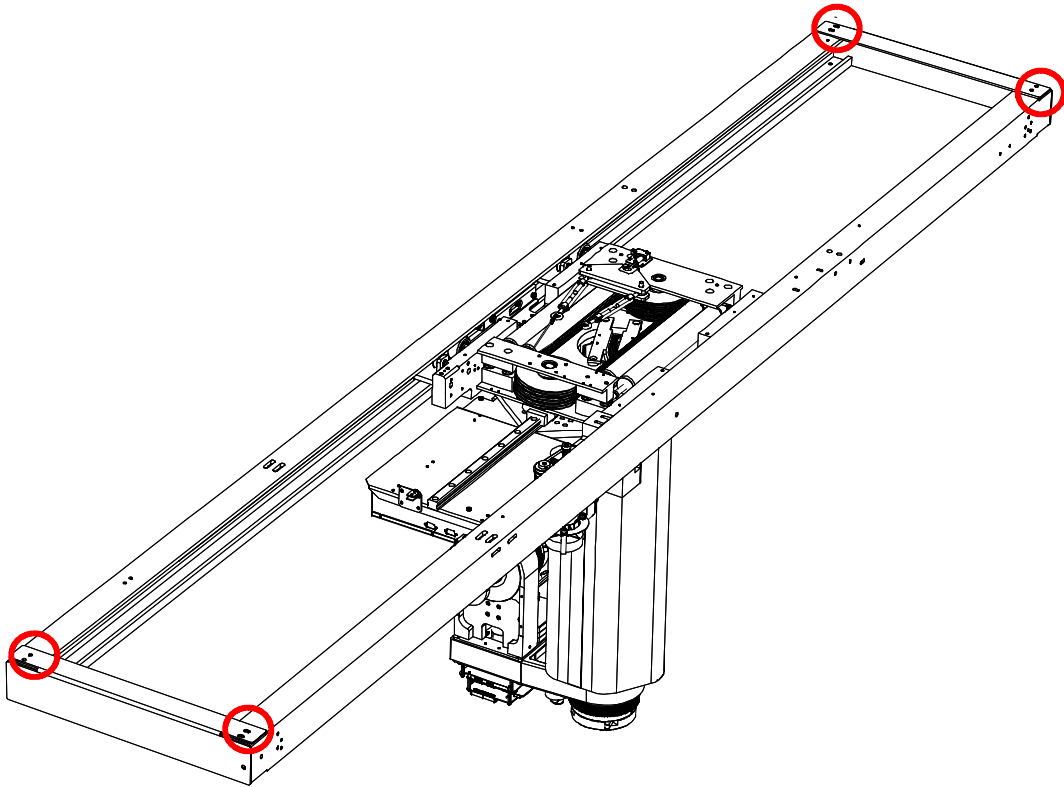

6. Use to fix both End Covers:
  - S0004605 SCREW M5 x 20 ISO 7380
  - 51383P30 BIG WASHER M5
  - 51361P03 LOCK NUT M5

7. Mount the Washer and Lock Nut under the Cover and the Screw on top of the Cover.

**Illustration 2-18**  
**Transverse Rails End Cover**



8. **Check if Transverse Rails are properly level and parallel:**
  - The distance between both rails must be the same in every point, with a tolerance of  $\pm 1$  mm (0.039"). Recommended checking points are located at a distance of 5 cm to 10 cm (1.97" to 3.94") from the end of every rail. Measure the distance from the external part of one rail to the external part of the other one.
  - All angles must be of  $90^\circ$ .

**Illustration 2-19**  
**Check all angles and distances (Bottom View)**

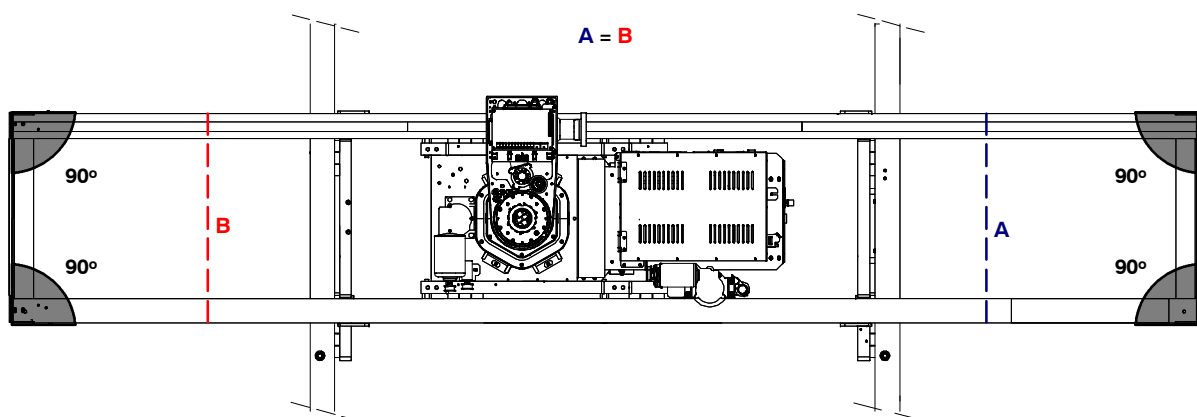

**PARALLELISM MUST BE CHECKED BEFORE LIFTING THE CEILING SUSPENSION TO FIX IT TO THE LONGITUDINAL RAILS, AND CHECKED AGAIN AFTER COMPLETING THE FIXATION PROCEDURE.**

Several parts of the Ceiling Suspension are fixed in Transverse Rails. Refer to illustration below for information about parts of the equipment fixed and their fixation points.

**Illustration 2-20**  
**Transverse Rails Fixations**

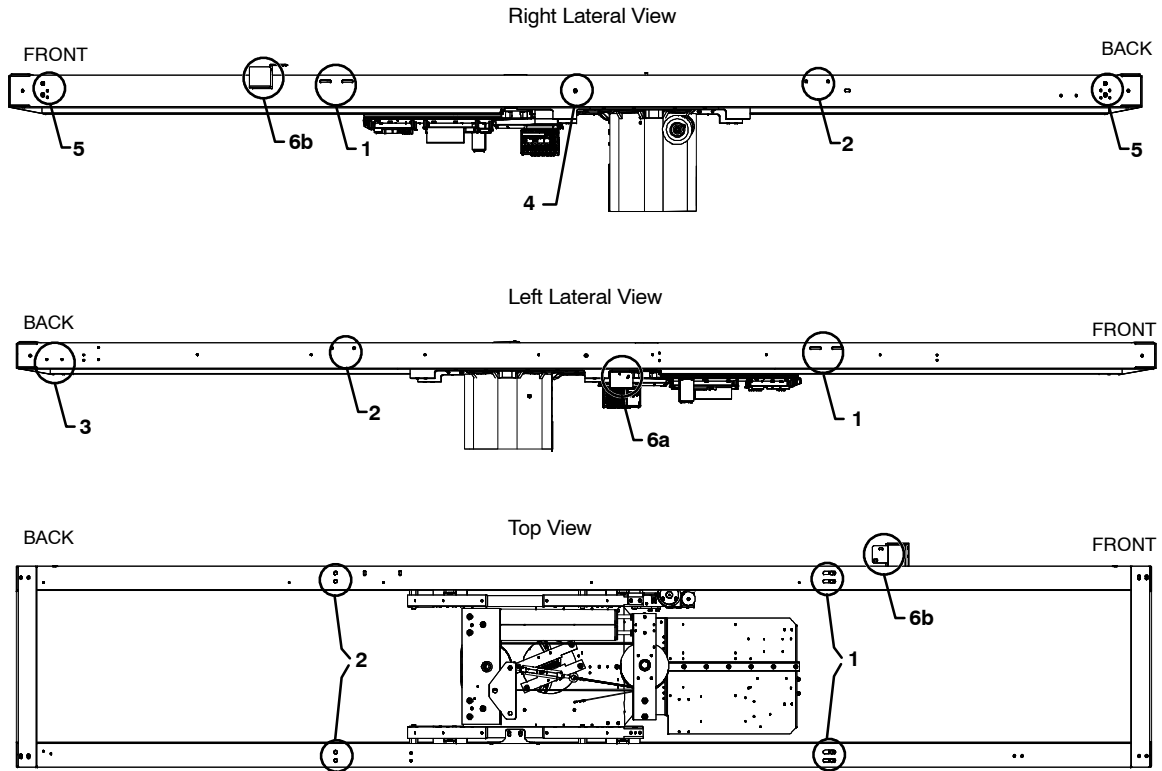

1. Front Transverse Rails Fixation
2. Back Transverse Rails Fixation
3. Bracket-Cable Mounting to the Transverse Rails
4. Mains Assembly Fixing Screw
5. Transverse Belt Fixation
6. Automatic Collimation Kit. Positions a & b

## 2.7 LIFTING & LOWERING

Note 

*In case of using another lifting tool, remember that it must comply with all the ceiling installation and safety requirements.*



**TO LIFT THE CEILING SUSPENSION NEITHER REMOVE ANY COVER OF THE MAIN ASSEMBLY SUPPORT, NOR MOUNTING BRACKETS, NOR MOUNTING BRIDGE.**



The Lifting Tool provided by the manufacturer is an optional tool, P/N S0006600. It can be used another tractel or lifting equipment, as long as it is capable to lift the main crate and the Transverse rails, refer to the *Section 1.5 Pre-installation Checks* for information about the equipment and crate weight.

It is required to use two Lifting Tools, install one at each Lateral of the crate.

**Illustration 2-30**  
**Lifting Tool and Rings Installation**

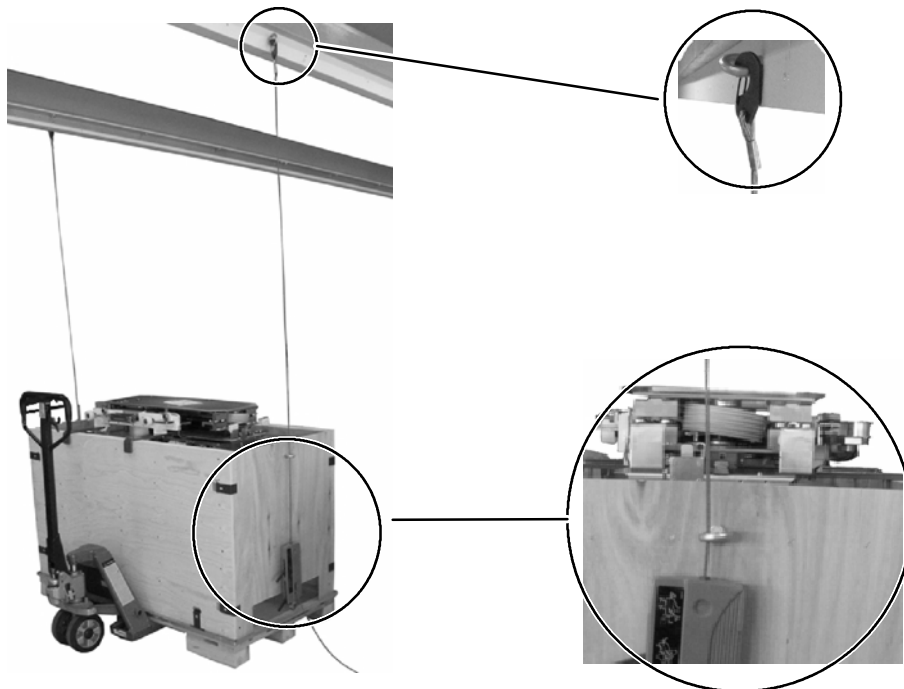

### 2.7.1 LIFTING TOOL INSTALLATION

1. Mount the rings required to the Lifting Tool installation. Two at the Longitudinal Rail, one at each rail. Other Two at the top of the Ceiling Suspension Crate, one at the front and at the back of the Crate (refer to *Illustration 2-30*).
2. Pass the Lifting Tool cables through the Crate rings.

**Illustration 2-31**  
**Crate Ring with Cable installed**



3. Pass the other lifting Cables through the gaps of the skids under the Crate to avoid unexpected overturns of the Crate during the lifting procedure.

**Illustration 2-32**  
**Drive the Cable through the Crate Skids**

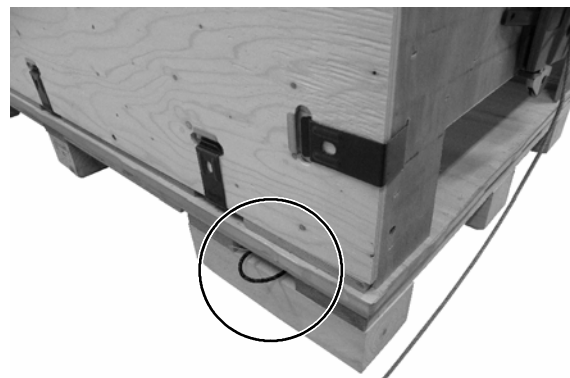
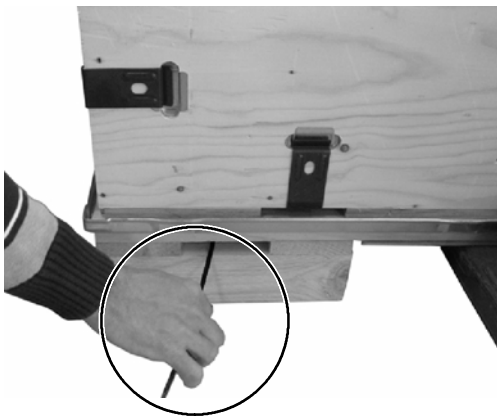

4. Hook the cables with the bottom hook of the Lifting Tool.

**Illustration 2-33**  
**Hook the Cables**

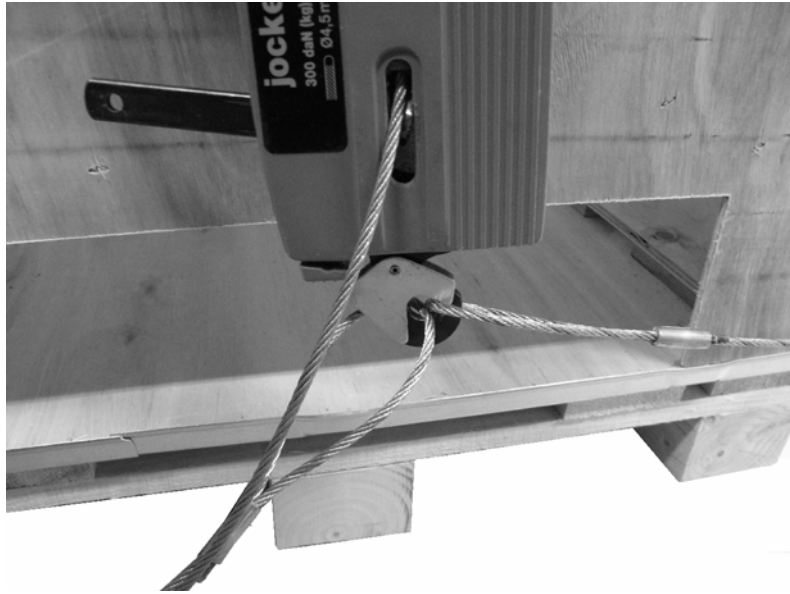

5. Adjust the steel cables just lifting a little bit the Crate. Make sure that there are not knots, cables are tightened and that Ceiling Suspension can be lift safely.

**Illustration 2-34**  
**Make sure that Lifting Tool is properly installed**



## 2.7.2 LIFTING & LOWERING

1. Place the bar as shown in Illustration 2-34, move up and down bar **A** at the same time in both tractels to lift the Main Crate.
2. Lift the Main Crate with Ceiling Suspension main assembly until the Transverse Rails are at 1 cm (0.39").

**Illustration 2-35**  
**Ceiling Suspension Lifting procedure**

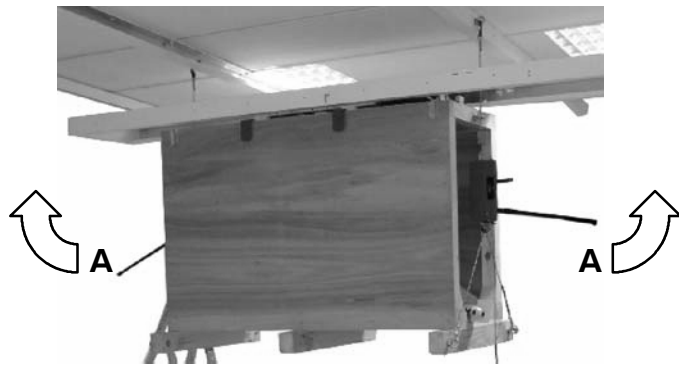

**PROCEED TO LOWER THE MAIN CRATE ONCE THE TRANSVERSE RAILS HAVE BEEN FIXED COMPLETELY TO THE LONGITUDINAL RAILS.**

3. Once the Transverse Rails and Ceiling Suspension are fixed to the Longitudinal Rails (*refer to Section 2.8*), unscrew the Mounting Brackets and Mounting Bridge from the Main Crate.
4. To lower the Main Crate, move up and down the bar **B** at the same time in both tractels.

**Illustration 2-36**  
**Ceiling Suspension Lowering procedure**

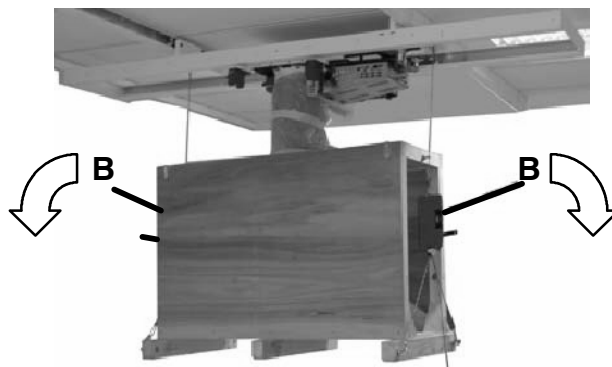

## 2.8 TRANSVERSE RAILS FIXATION

This procedure's target is to provide information about the fixation of the Transverse Rails Fixation Bearings or Rolling Supports that allow the movement of the Ceiling Suspension and the Transverse Rails along the Longitudinal Rails. There are two Fixation Bearings to be installed, Front and Back Bearings. **Remember that they are not interchangeable.**

Note 

*It is highly recommended to get the Ceiling Suspension and Transverse Rails mounted and lifted together to install the Fixation Bearings.*

**Illustration 2-37**  
**Fixation Bearings location**

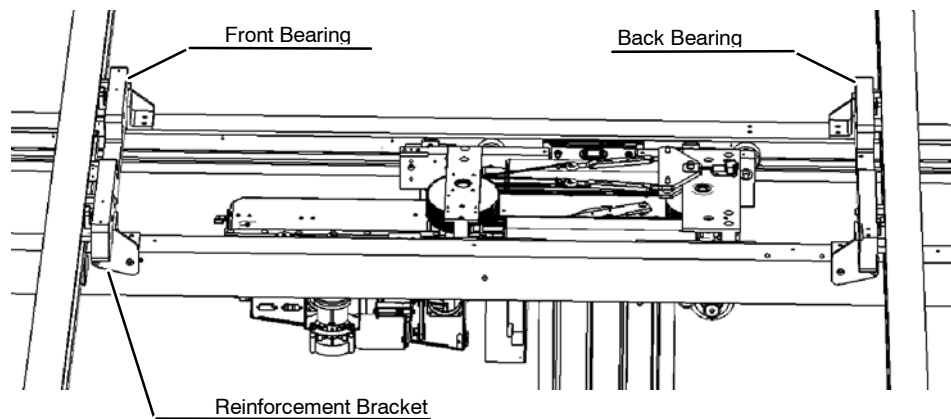

**FRONT AND BACK FIXATION BEARINGS ARE DIFFERENT AND NOT INTERCHANGEABLE. MAKE SURE THAT EACH ONE IS INSTALLED IN ITS CORRECT POSITION. IT IS MANDATORY TO INSTALL FIRST THE BACK BEARING AND THEN THE FRONT ONE.**

## REQUIRED ELEMENTS

BOX	P/N	DESCRIPTION	QTY.
N/A	S0009430	Conductive Rolling Support (Back Fixation Bearing)	1
	S0009433	Brake Side Rolling Support (Front Fixation Bearing)	1
A	S0009340	Reinforcement Bracket for Rolling (Right Side)	2
	S0009341	Reinforcement Bracket for Rolling (Left Side)	2
	51212P71	Screw DIN 912 M6x40	8
	51221P68	Allen Screw M6x25 DIN7991	8
	51361P04	Nut EX with nylon Lock M6	16
	51380P28	Plate Washer B 6.4	16
2	S0006260	Bracket Plate Fixation Rails (Small)	4
	51390P13	Washer AET M8	8
	51201P48	Screw EX M8x25	8
	51380P29	Washer B 8.4 AO	8

**Illustration 2-38**  
**Rails Fixation and Bearing Assemblies**

**Front Fixation Bearing**

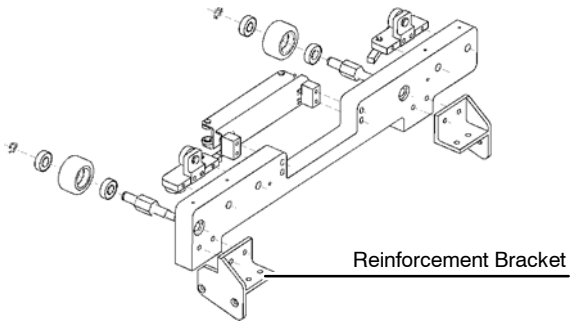

**Back Fixation Bearing**

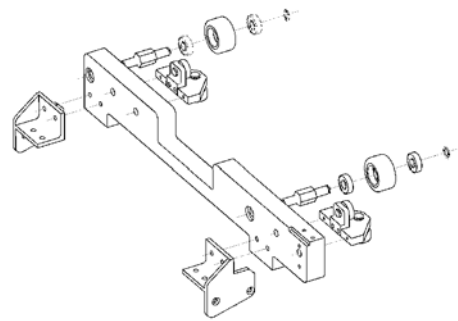

## 2.8.1 BACK BEARING INSTALLATION



**THE CEILING SUSPENSION AND TRANSVERSE RAILS MUST BE ALREADY SUPPORTED BY THE MAIN CRATE AND THE LIFTING TOOL. DO NOT REMOVE ANY UNTIL PROPERLY FIXING THE TRANSVERSE RAILS.**

1. Open Packing Box A.
2. Place the Fixation Bearing in the left lateral of the Transverse Rails. Insert the Bearing into the back Longitudinal Rail.

**Illustration 2-39**  
**Roll the Back Bearing to install it**

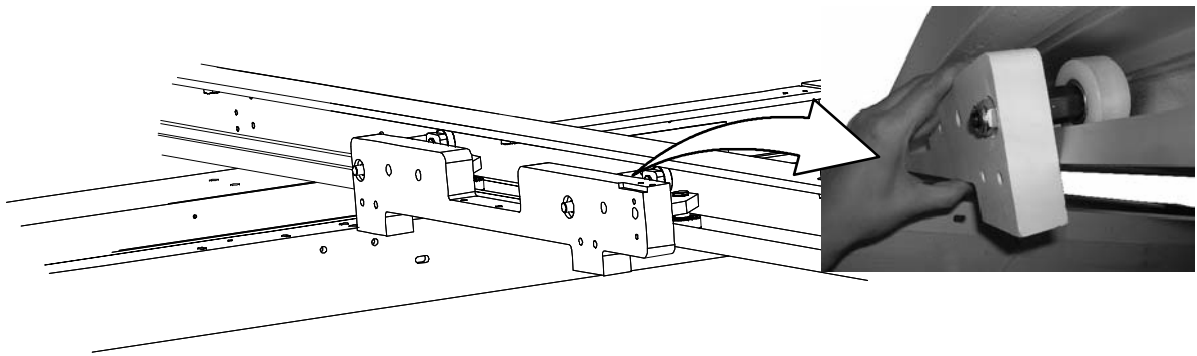

3. Roll the Bearing to its final position, it must match the Transverse Rails bores for Bearing fixation.

**Illustration 2-40**  
**Place the Fixation Bearing in the correct position**



4. Each Fixation Bearing is fixed directly to the Transverse Rail with all the screws and items shipped in packing Box 2. Open it.
  - S0006260 Bracket Plate Fixation Rails
  - 51390P13 Washer AET M8
  - 51201P48 Screw EX M8x25
  - 51380P29 Washer B8.4 AO

**Illustration 2-41**  
**Bearings fixation screws**



5. Turn just twice, for the moment do not fix it definitely, the distance of the Fixations Bearings to the Longitudinal rails must be adjusted before definitive fixation.

**Note** 

*Do not fix completely all screws until adjusting the distance of both Fixation Bearings to the Longitudinal Rails.*

## 2.8.2 FRONT BEARING INSTALLATION

Proceed to install the front Bearings completing the same steps as for the back bearings installation.

1. Transverse Rails slotted bores allow the correct adjustment of the Bearing distance to the front Longitudinal Rails.

**Illustration 2-42**  
**Front Bearing Fixation Screws**



2. Adjust the distance from both bearings to the Longitudinal rails at  $13 \pm 1 \text{ mm}$  ( $0.51 \pm 0.04''$ ). Make sure the distance is the same in all points.

**Illustration 2-43**  
**Check the Distance (Bottom View)**

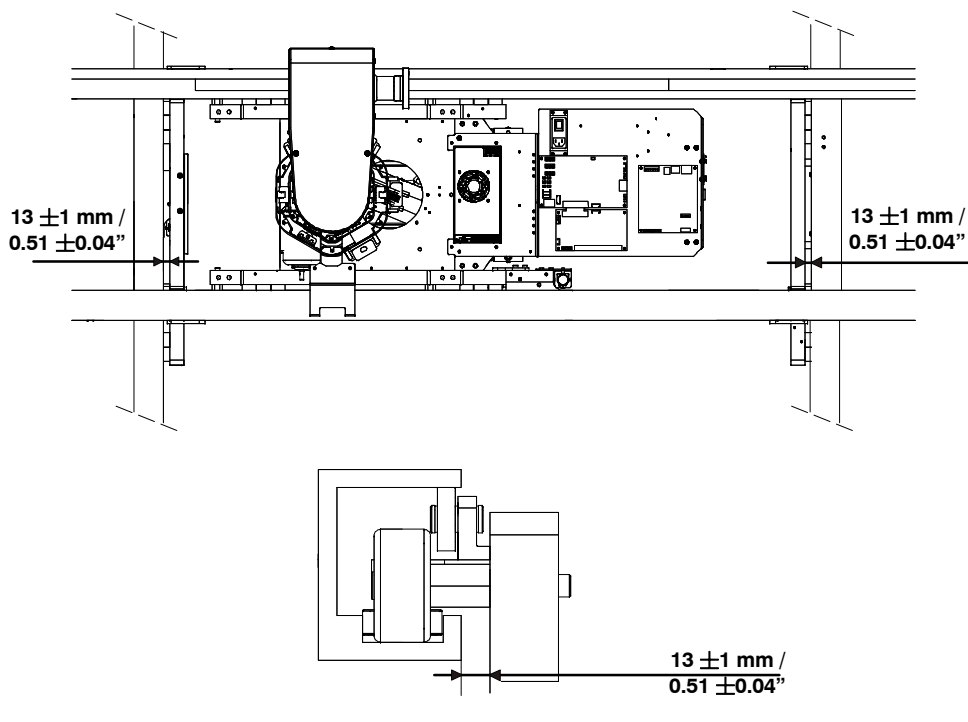

3. Tighten all Bearings fixation screws definitively making sure that the distances between the Bearings and the Longitudinal rails are correct.
4. In case the distances are not correct, proceed to check the installation of the Bearings and use the slotted holes to adjust them.
5. Lower the Main Crate (*refer to Section 2.7.2*).
6. Unscrew and remove the Mounting Brackets and the Mounting Bridge from the Ceiling Suspension Main Assembly and remove any shipping element from the Ceiling Suspension.

**Illustration 2-44**  
**Mounting Brackets removal**

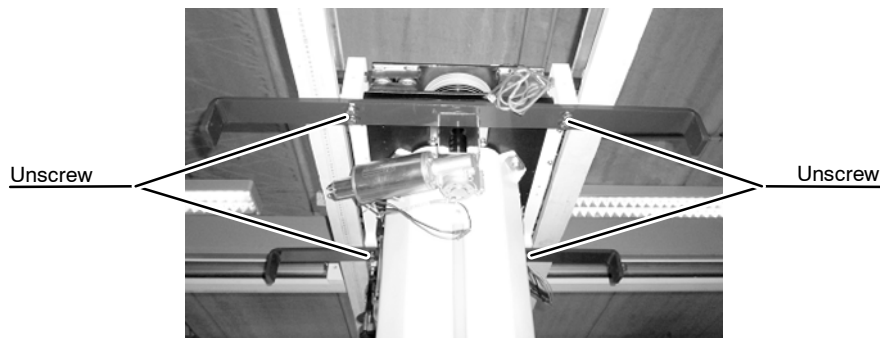

7. Check the Transverse Rails Leveling.

**Illustration 2-45**  
**Check Leveling**

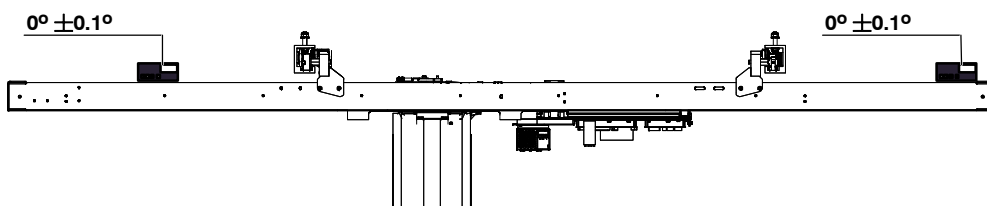

### 2.8.3 REINFORCEMENT BRACKETS INSTALLATION

1. Install the Reinforcement Brackets, there are two different pairs:
  - **S0009340** Reinforcement Bracket for both right Sides.
  - **S0009341** Reinforcement Bracket for both left sides.

**Illustration 2-46**  
**Reinforcement Brackets installation**

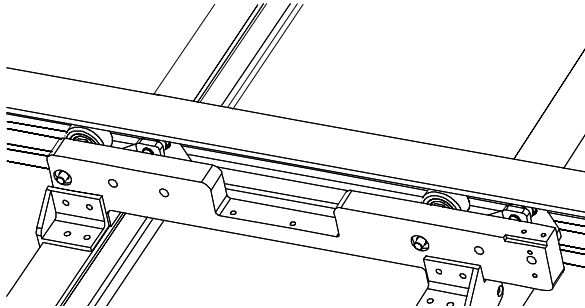

2. Use to fix the Brackets to Bearings:
  - Allen Screw M6x25 DIN7991
  - Plate Washer B 6.4

**Illustration 2-47**  
**Reinforcement Brackets Fixation to Bearings**



3. Use to fix the Brackets to the Transverse Rails:
  - 51212P71 Screw DIN 912 M6x40
  - 51361P04 Nut EX with Nylon Lock M6

**Illustration 2-48**  
**Fix the Brackets to the Transverse Rail**



## 2.9 LONGITUDINAL POTENTIOMETER & BELT INSTALLATION

Remember that:

- Longitudinal Belt, P/N S0020135, is installed on the back Longitudinal Rail.
- Longitudinal Potentiometer, P/N S0023450, is installed on the back Fixation Bearings.



*As just one Belt is shipped for both axis, make sure that the required length is used to the installation in the axis. For the Longitudinal Belt it is required almost 6200 mm (244”).*

**Illustration 2-49**  
**Longitudinal Potentiometer and Belt**

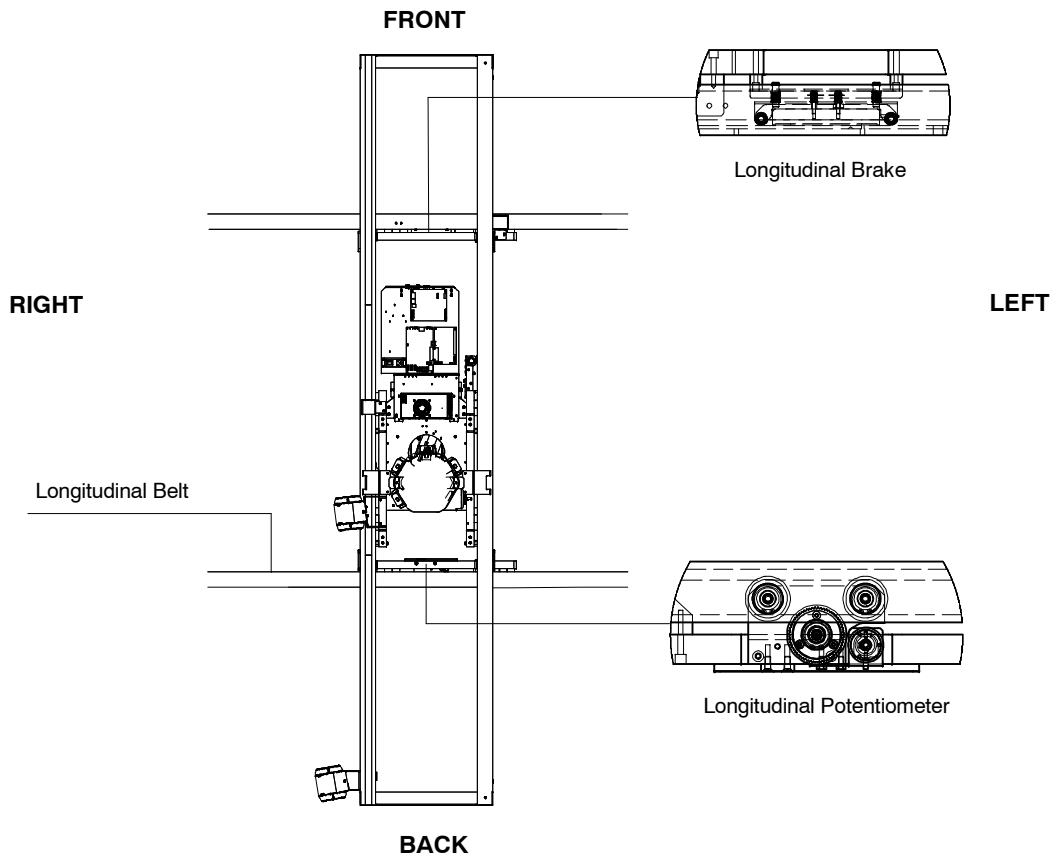

**Illustration 2-50**

**Install the Pulleys and Belt in the same axis where the WS will be installed**

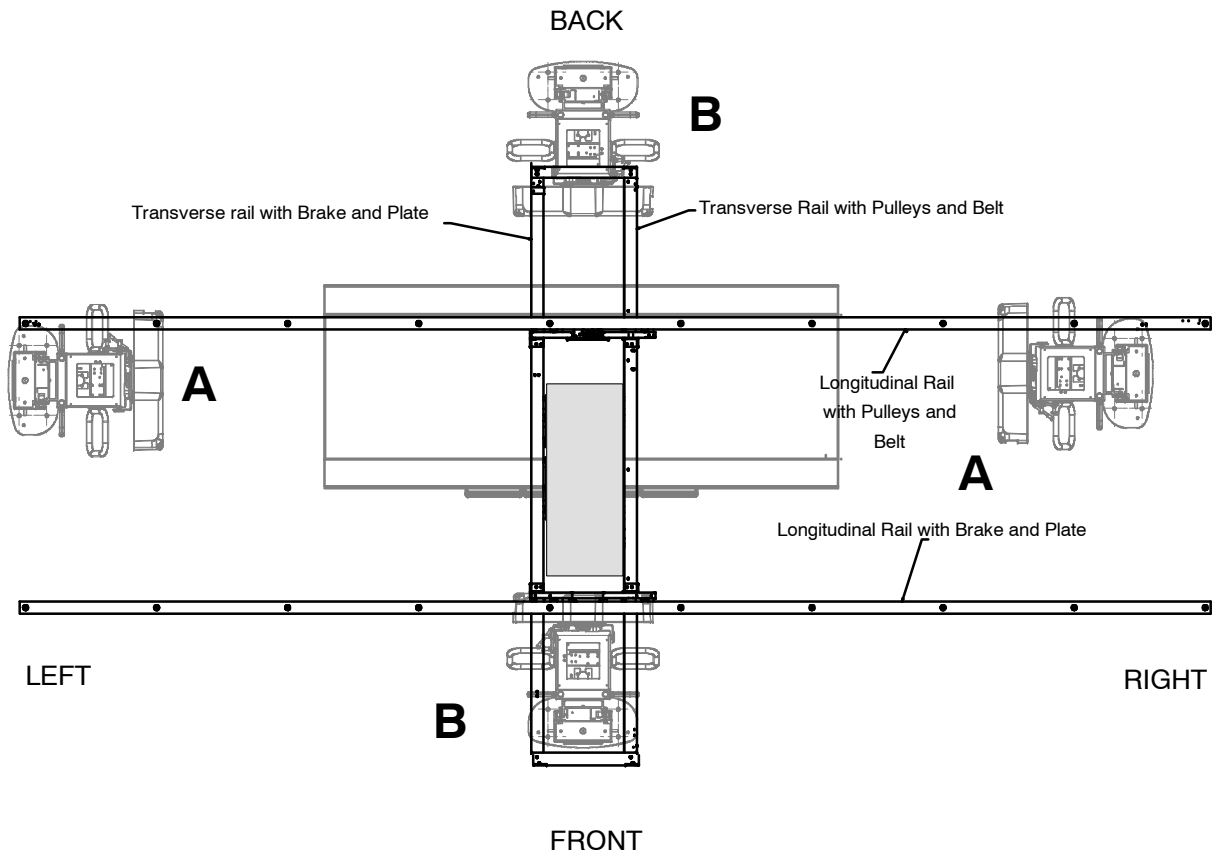

- A** Wall Stand on Ceiling Suspension Longitudinal Axis, Pulleys and Belt installed only on the Longitudinal Axis.
- B** Wall Stand on Ceiling Suspension Transverse Axis, Pulleys and Belt installed only on the Transverse Axis.

## REQUIRED ELEMENTS

BOX	P/N	DESCRIPTION	QTY.
B	S0020135	Belt Assembly	6.2 m (244")
	S0023450	Longitudinal Potentiometer Assembly (Pulleys Set)	1

**Illustration 2-51  
Longitudinal Belt and Potentiometer**

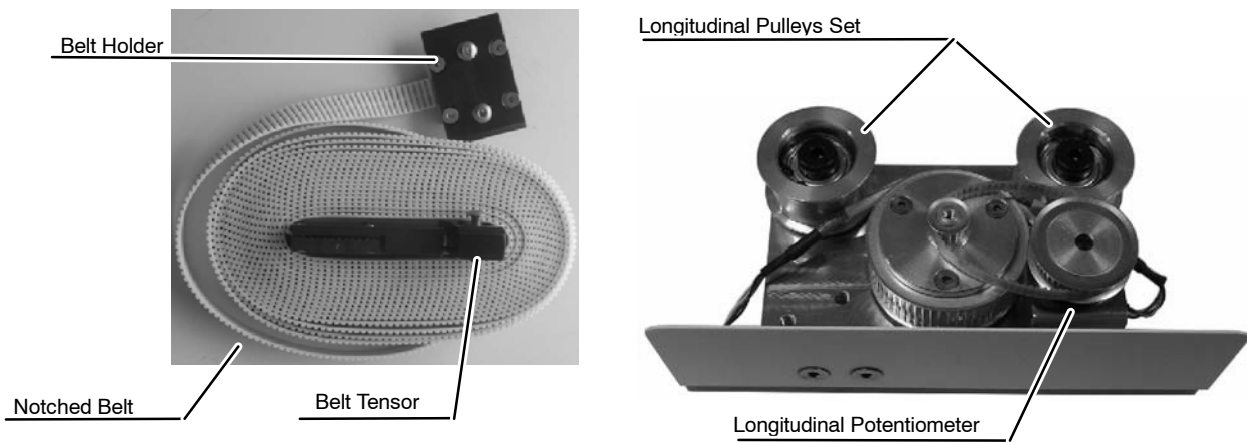

***For Standard Ceiling Suspensions both Belts, Transverse and longitudinal, are packed in the same shipping box, B, in the Main Crate. Please make sure that the required Belt for each rail is used. The use of the wrong Belt will result in the impossibility to continue with the whole installation procedure.***

***Check the lengths of both Belts. Longitudinal Belt is the longest one (6200 mm, 244”).***



***For Auto-tracking Ceiling Suspensions it is not necessary to install both Belts. Depending on the Room configuration, it will be necessary to install the Belt and Pulley Set in the Transverse Axis or in the Longitudinal one. So, just one Belt is shipped for both axis, make sure that the required length is used to the installation in the axis. For the Longitudinal Belt it is required almost 6200 mm (244”). Install the Pulleys Set and Belt in the same axis where the Wall Stand will be installed.***

## INSTALLATION PROCEDURE

1. Open Packing Box P and use the Longitudinal Belt packed in Packing Box B.
2. Get the Belts along the back Longitudinal Rail (without metallic Brake Plate). The notched Belt must run with all notches facing inwards or to the rail.

**Illustration 2-52**  
**Get the Longitudinal Belt Tightened**

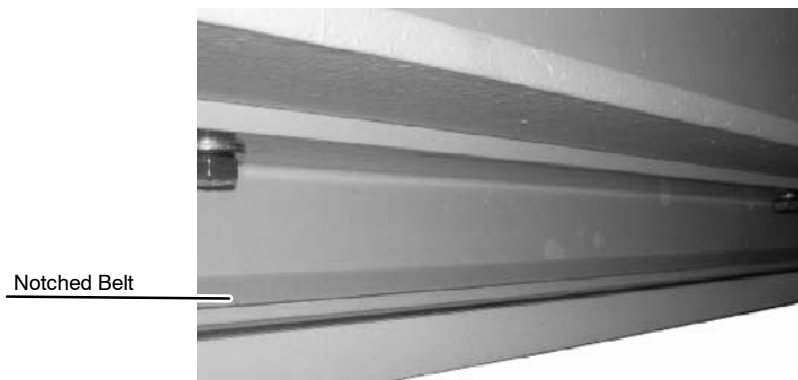

3. Loosen the Jam Nut of the Belt Tensor, it must be a little bit loose.

**Illustration 2-53**  
**Loosen the Belt Tensor Jam Nut**

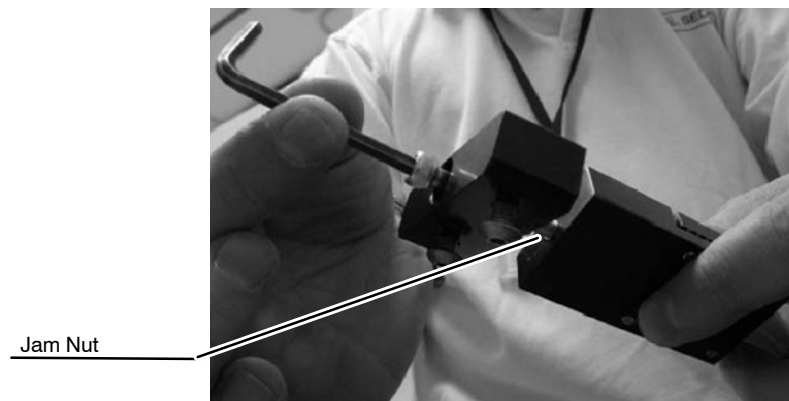

4. Fix the Belt Tensor tightening the two fixing screws in the outer side of the rails.

**Illustration 2-54**  
**Fix the Belt Tensor**



5. Loop the Belt into the Longitudinal Motor Pulleys set as shown in Illustration 2-55.

**Illustration 2-55**  
**Loop the Longitudinal Belt into the Pulleys**

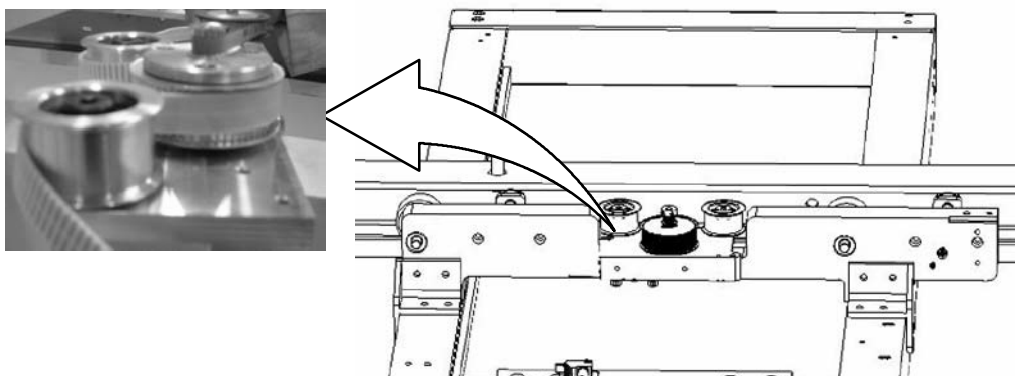

6. Open the Belt Holder to fix the Belt and fit both notches.

**Illustration 2-56**  
**Belt Holder**

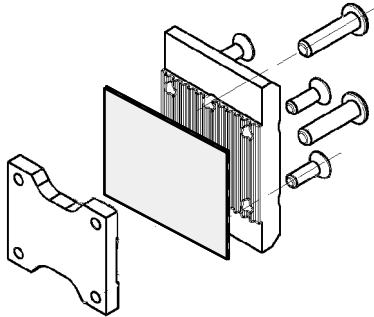

7. Mount again the Belt Holder to fix the Belt and fix it completely to the Rails.

**Illustration 2-57**  
**Fix the Belt Holder**



8. If wanted, cut the remaining tooth Belt as it is not necessary.
9. Finally get the Belt tightened. Turn the Tensioning Screw to get the Belt tightened.

**Illustration 2-58**  
**Adjust the Belt Tensioner**

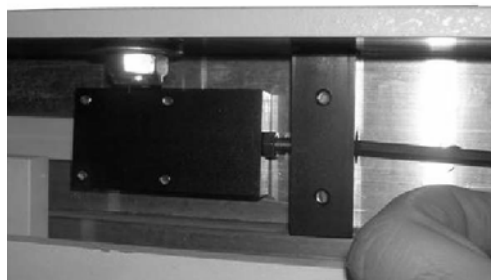

10. Fix the holder to the Longitudinal Rail.

11. Center the suspension in the room and adjust the Longitudinal Potentiometer at its center too. Give 5 turns, as it is a 10 turns one.

**Illustration 2-59**  
**Longitudinal Potentiometer**

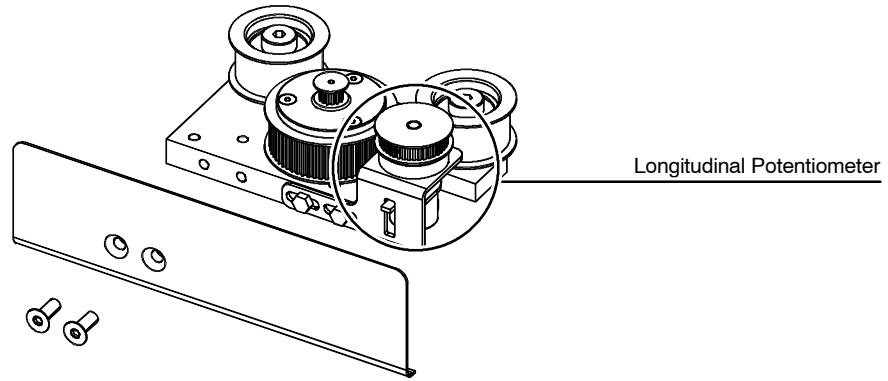

12. Connect the Longitudinal Potentiometer Cable.
13. Fix the Longitudinal Potentiometer Cover.
14. Fix the Cable to the Transverse Rails.

There are six different cables fixation points on Transverse Rails.

**Illustration 2-60**  
**Cables fixation points on Transverse Rails marked in red**

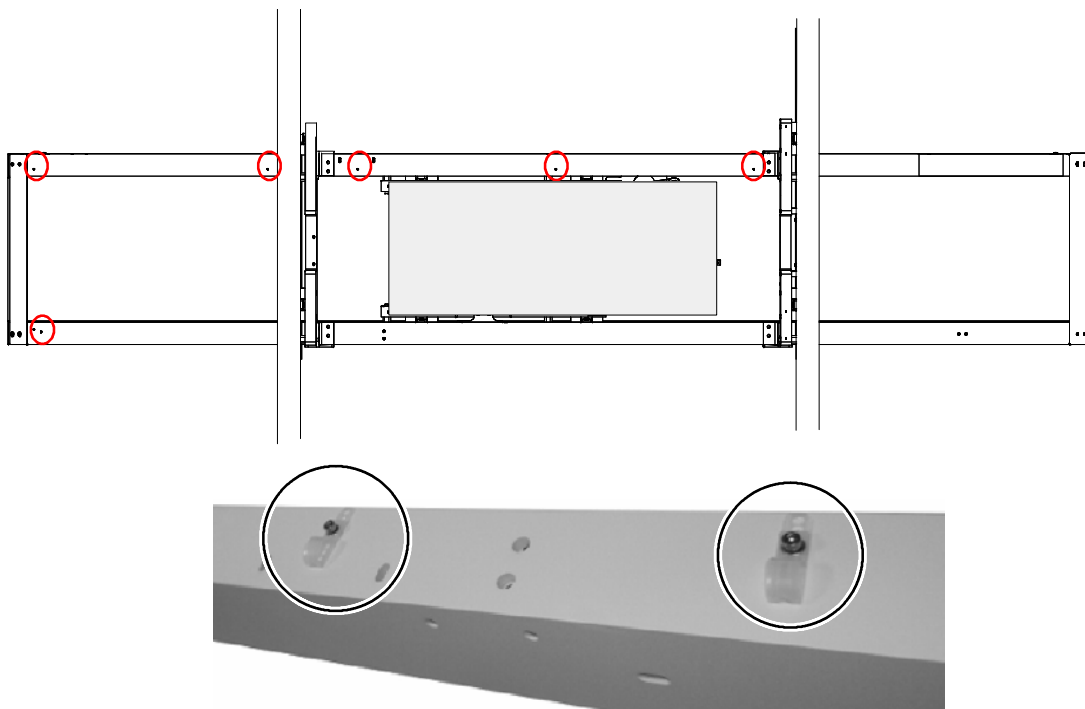

## 2.10 LONGITUDINAL BRAKE INSTALLATION

### REQUIRED ELEMENTS

BOX	P/N	DESCRIPTION	QTY.
C	S0016937	Longitudinal Brake	1
	51212P72	Screw M6x45	4
	51390P12	Washer AET M6	4
3	53054P01	Tie Wrap UNEX1201	6
	51212P25	Screw DIN912 M4x12	6
	51380P26	Washer DIN125 M4	6
	51390P10	AET Washer M4	6

**Illustration 2-61**  
**Longitudinal Brake**

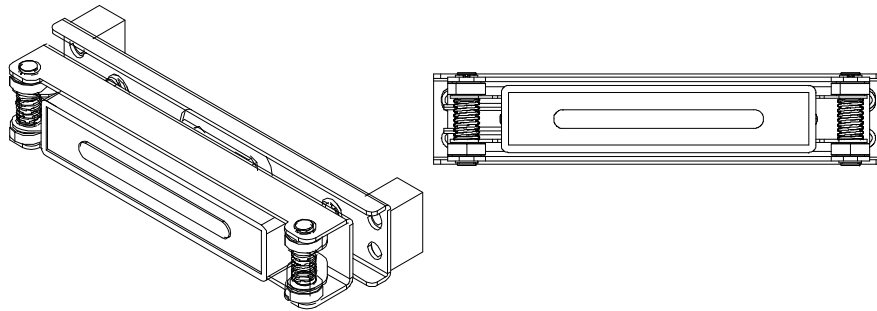

### INSTALLATION PROCEDURE

1. Insert the Longitudinal Brake between the Front Fixation Bearing and the Front Longitudinal Rail.

**Illustration 2-62**  
**Longitudinal Brake Location**

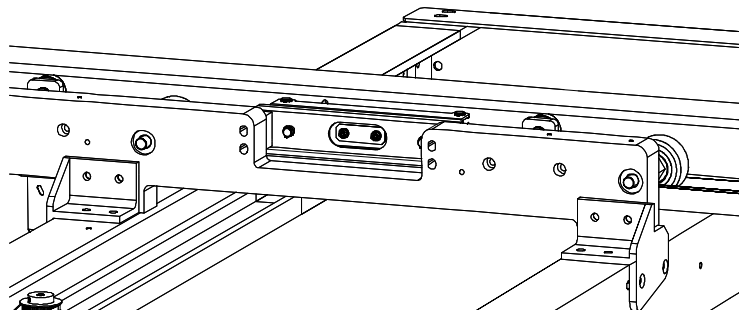

2. Tighten the four fixation screws to fix it to the Bearing.
  - 51212P72, Screw M6x45
  - 51390P12, Washer AET M6

**Illustration 2-63**  
**Longitudinal Brake Fixation and Connection**



3. Connect the Brake Cable to the Cable, P/N S0005069, which is connected to the Control Board, P/N S0019874. Refer to the General Connections Schematics:
  - S0024598SCH for the Standard Ceiling Suspension
  - S0024170SCH for the Auto-tracking Ceiling Suspension
4. Fix the Longitudinal Brake Cable to the Transverse Rails, use:
  - 51212P25, Screw DIN912 M4x12
  - 51380P26, Washer DIN125 M4
  - 51390P10, AET Washer M4

## 2.11 TUBE SUPPORT & X-RAY TUBE INSTALLATION

### 2.11.1 TUBE SUPPORT ADAPTATIONS

Tube adaptation kits will be supplied to allow the correct assembly and fixation of the X-ray tubes to the ceiling suspension and provide compatibility. Each of these adaptation kits is composed of fixation rings, console fixture and suspension fixture. All components are designed for the specific characteristics of the X-ray tubes (type, dimensions, weight...).

*Note* 

*Only tubes with a horn angle between 90° and 180° can be mounted on the Ceiling Suspension.*

**Illustration 2-64**  
**Allowed orientations for Tubes**

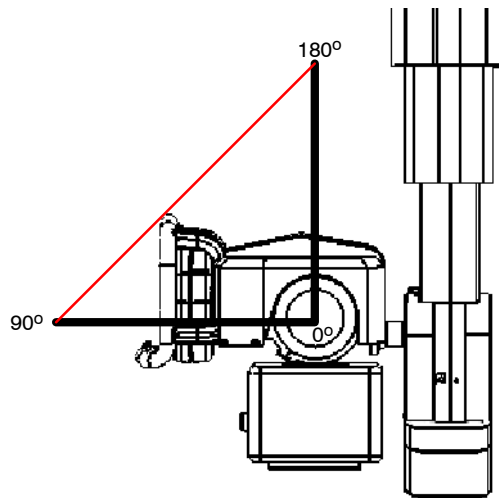

*Note* 

*For further information about X-ray Tubes installation, please refer to their own technical documentation, which is provided together with the Suspension and the X-ray Tube.*



**WARNING**

**DUE TO THE HEAVY WEIGHT OF OPTIONAL X-RAY TUBES, PROCEED ALWAYS ACCORDING TO THE LOCAL ERGONOMICS AND WORKING CONDITIONS NORMATIVE.**

There are different X-ray Tube Supports Adaptations depending on the tube:

TUBE SUPPORT ADAPTATION	HOUSING	INSERT	FOCAL SPOT	TARGET ANGLE	ANODE HEAT CAPACITY (KHU)	SPEED
<b>A11108-01</b> (Toshiba E7252 Tube Adaptation)	Toshiba E7239X & FX	N/A	1.0 - 2.0	16°	140	Low
	Toshiba E7240X & FX	N/A	0.6 - 1.2	12°	140	Low
	Toshiba E7242X & FX	N/A	0.6 - 1.5	14°	200	Low
	Toshiba E7252X & FX	N/A	0.6 - 1.2	12°	300	High/Low
	Toshiba E7299X	N/A	0.3 - 1	12°	140	Low
	Toshiba E7843X	N/A	0.6 - 1.2	12°	150	Low
	Toshiba E7865X	N/A	0.3 - 1	12°	140	Low
	Toshiba E7876X	N/A	0.6 - 1.2	12°	230	Low
	Toshiba E7884X	N/A	0.6 - 1.2	12°	300	Low
	Varian Diamond	Any one of 71 mm (2,8")	Variable depending on the insert			High/Low
<b>A11109-01</b> (Toshiba E7254 Tube Adaptation)	Toshiba E7254X & FX	N/A	0.6 - 1.2	12°	400	High/Low
	Varian Sapphire	Any one of 100 mm (4")	Variable depending on the insert			High/Low
<b>A11110-01</b> (Toshiba E7869 Tube Adaptation)	Toshiba E7100X	N/A	0.6 - 1.2	12°	300	High/Low
	Toshiba E7869XX	N/A	0.6 - 1.2	12°	600	High/Low
<b>A11113-01</b> (Universal Adaptation)	Varian B130_90°	Any one of 102 mm (4")	Variable depending on the insert			High/Low
	Universal Tube Adaptation	Tube Support Adaptation compatible with non standard tubes: Comet DO-7/DO9/DO-10 Maxiray MX75-09R				
<b>A11113-02</b> (Universal - Varian Adaptation)	Varian B199_90° (SG-292, SG-296, SG-1096) Siemens 100L	Any one of 102 mm (4") and 120 mm 4.75")	Variable depending on the insert			High/Low

**Note** 

*In case of non Standard X-ray Tubes contact with Technical Service for detailed information.*

## STANDARD TUBE SUPPORT ADAPTATIONS

The components of the A11108-01, A11109-01 and A11110-01 Tube Support Adaptations are the same but with different measures depending on the Tube size and diameter.

POS.	DESCRIPTION	QTY.	REMARKS
1	Tube Support	1	
2	Symmetric Tube Holder	2	
3	Tube Holder	2	
4	Console Support Adapter	1	
5	Console Support	1	
6	Hose Support	1	
7	Tube Top Cover	1	
8	Tube Bottom Cover	1	

**Illustration 2-65**  
**Standard Tubes Adaptations**

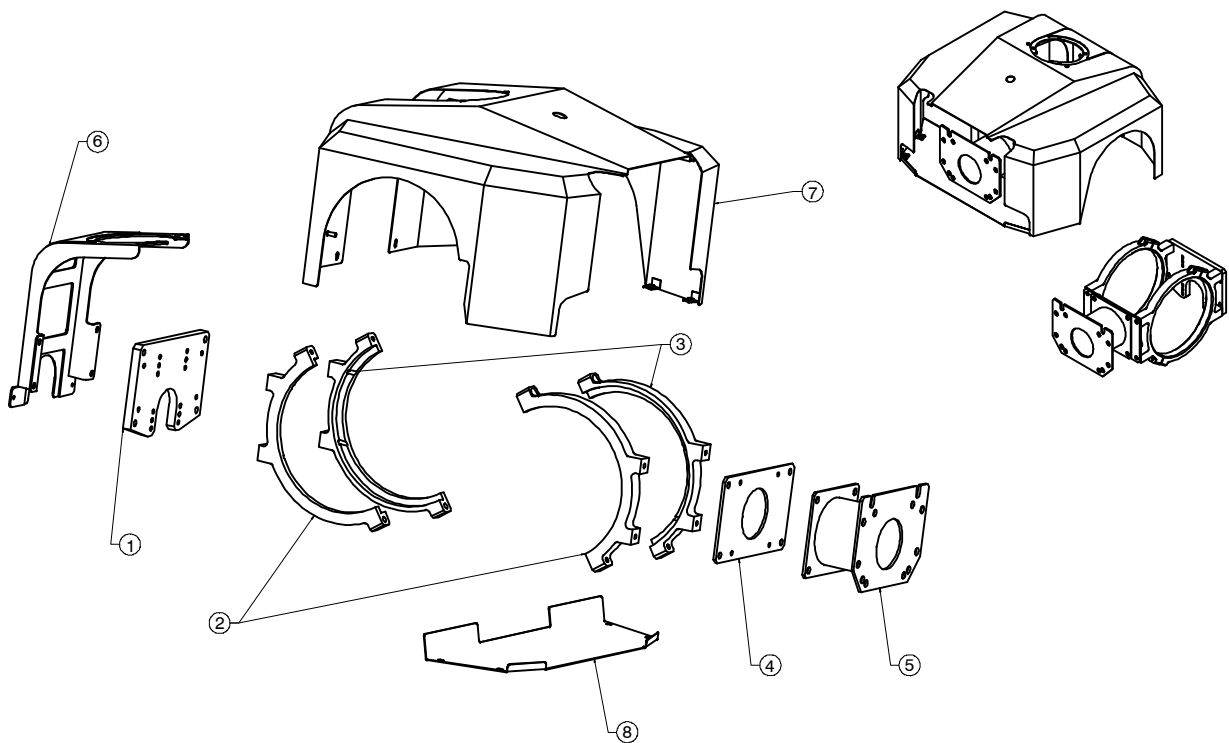

## 2.11.2 BETA AND ALPHA COVERS REMOVAL

To install the X-ray Tube and External hose it will be required to remove both Alpha and Beta Covers.

1. **Beta Cover.** Remove both bottom screws.

**Illustration 2-67**  
**Beta Cover Screws**

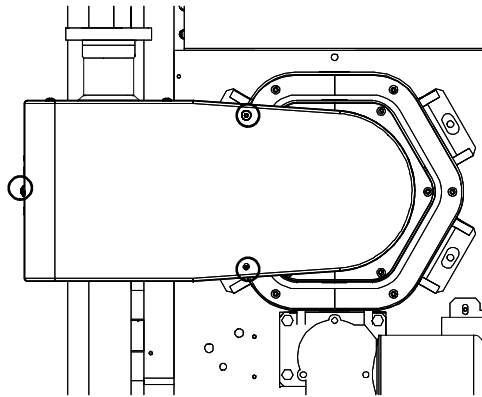

2. **Alpha Covers:**

- Loosen both front cover screws to remove the Alpha Front Cover.
- Loosen the three screws to remove the Alpha Cover. One at the side and two at the bottom (inside the Beta body).

**Illustration 2-68**  
**Alpha Cover Fixation**

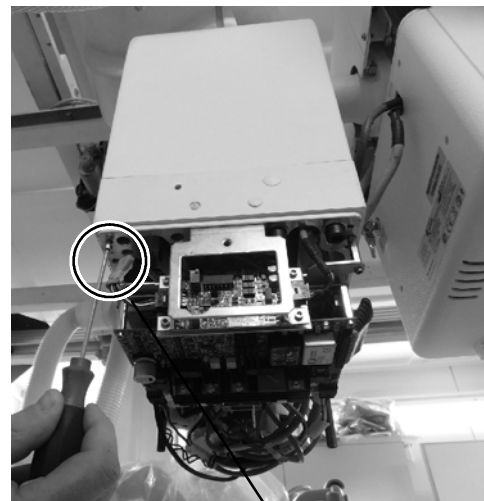
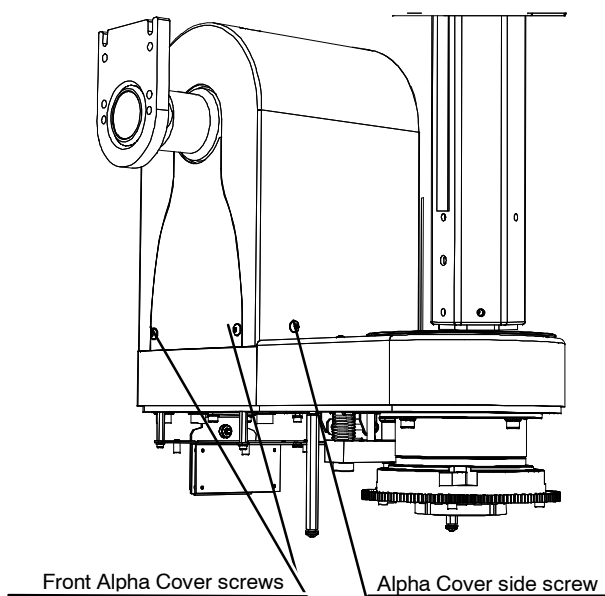

### 2.11.3 TELESCOPIC COLUMN LOWERING

Depending on the height of the ceiling the Tube Support may be too high to work properly. Get the Telescopic Column lowered when required to work more comfortably during the X-ray Tube, Collimator and Control Console installation, and use a ladder to complete installation procedures.



**PLEASE, PROCEED ALWAYS ACCORDING TO THE LOCAL ERGONOMICS AND WORKING CONDITIONS NORMATIVE.**

The Vertical Motor is servo assisted. It means that when it is connected, it controls both vertical motions, upwards and downwards, no matter if the Ceiling Suspension is switched ON or OFF, in order to allow a soft movement without unsteady movements or stumblings.

*Note* 

*Due to safety reasons the Motor fixes totally the Telescopic Column, so it will be impossible to move it down without get it free.*

1. The Vertical Motor is tied to the Telescopic Column by a flexible coupling. Loosen **just** the top screw of the coupling to free the Column.

*Note* 

*Do NOT ever loosen the bottom Fixation screw of the Motor Coupling. To free the Column, it is only required to loosen the top screw and as soon as the Telescopic Column has been moved down to the desired position, fix it back.*

**Illustration 2-69**  
**Coupling Fixations**

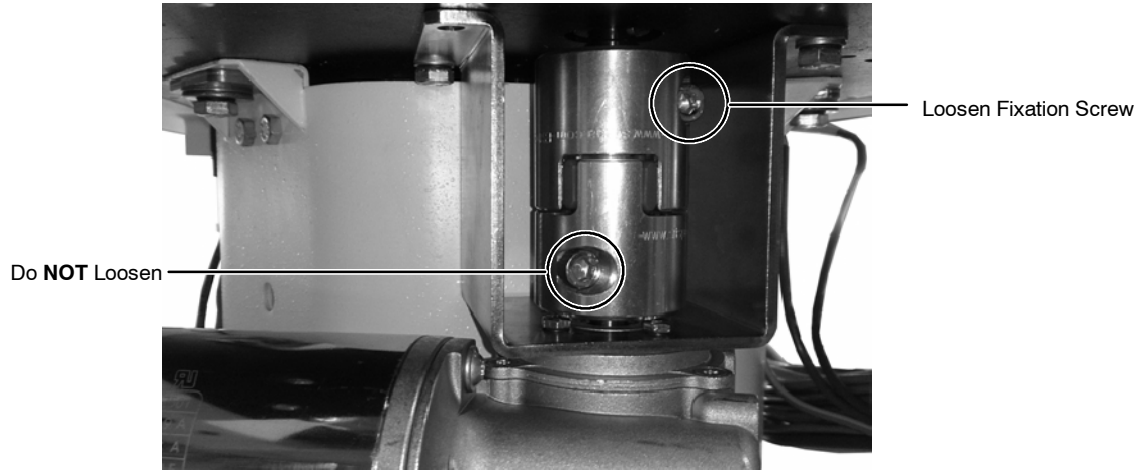

2. Remove the Fixation Pin from the Telescopic Column, and get this tool stocked as a maintenance tool.

**Illustration 2-70**  
**Remove the Telescopic Column Fixation Pin**



#### 2.11.4 X-RAY TUBE INSTALLATION

Disassemble the Tube Support Adaptation, which is formed by two different assemblies, as it is shipped assembled (*refer to Section 2.11.1*).

1. Remove all the Covers from the Assembly (position 7 and 8 of Standard Adaptation or 3 of the Universal Adaptation.)
2. For Standard tubes adaptations, split the Tube Holder in two. Remove the Symmetric Tube Holder and remove the Hose Support.

#### Illustration 2-73

#### Split Tube Holder and remove Console Support

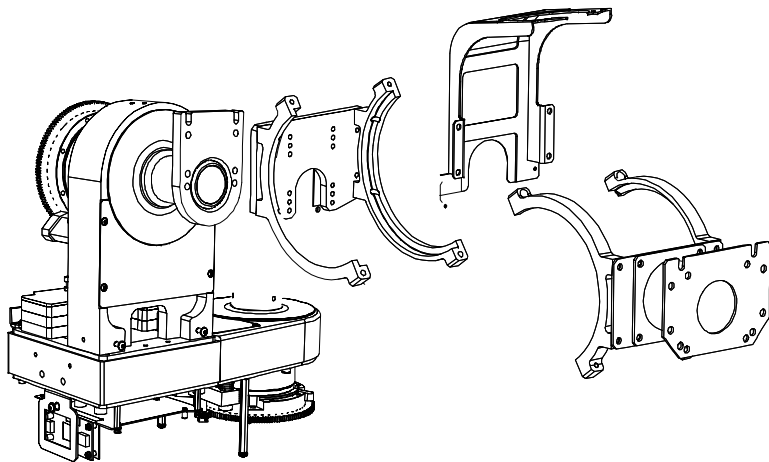

3. Install the Tube Support and Tube Holder on the Alpha/Beta Assembly. Install both upper screws on the Tube Support and hang it on the Adaptation Support. Then Tighten the bottom screws.

- There are three different pairs fixation holes. Default tubes are mounted on Central Holes.

**Illustration 2-74**  
**Tube Support Configurations**

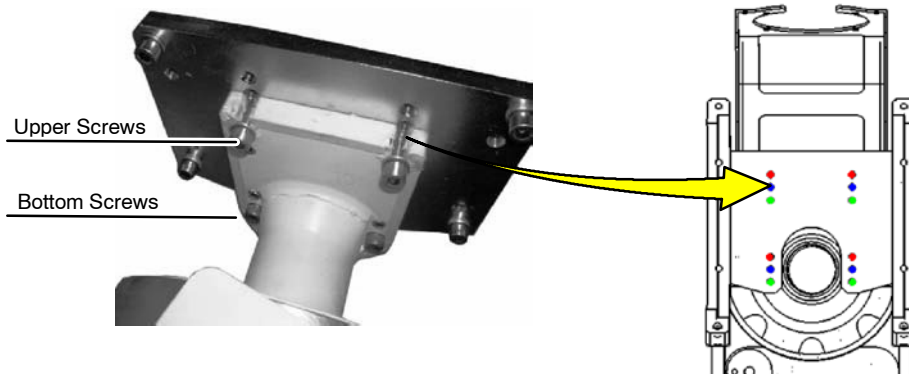

**Note** 

*When mounting different X-ray Tubes and/or Collimators, please get in contact with Manufacturer Technical Service.*

- Mount the X-ray Tube on the Tube Support.

**Illustration 2-75**  
**Tube Installation on Tube Holder**

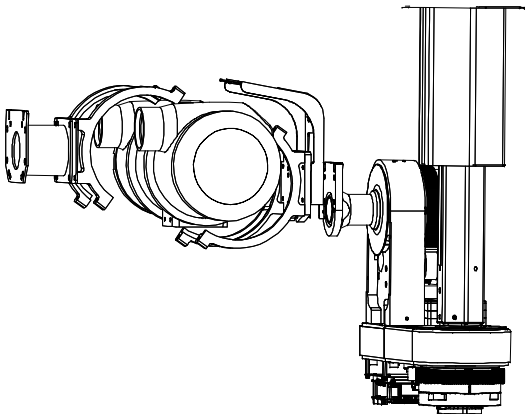

**DUE TO THE HEAVY WEIGHT OF OPTIONAL X-RAY TUBES, TWO FIELD ENGINEERS ARE REQUIRED TO COMPLETE THE X-RAY TUBE INSTALLATION. PLEASE, PROCEED ALWAYS ACCORDING TO THE LOCAL ERGONOMICS AND WORKING CONDITIONS NORMATIVE.**

6. Get the Tube properly centered and fitted to the Tube Holders.
7. Assemble the Symmetric Tube Holder with the Console Support.

**Illustration 2-76**  
**Center the Tube and fix all Holders**



8. Tighten the screw to fix the Tube. Do not fully tighten them, it is required to get the tube properly level and aligned before fixing it definitely.

**Illustration 2-77**  
**Fix both Tube Holder Parts**

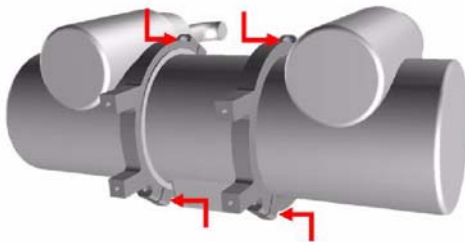

**Note** 

***Do not install the X-ray Tube Covers yet. Wait to complete the whole installation procedure before connecting all cables. Proceed when indicated in the following installation steps.***

### 2.11.5 TUBE LEVELING

Proceed first with the X-ray Tube adjusting and leveling, right after its installation and before mounting the Collimator. Once it is installed check the leveling and adjustment of the X-ray Tube.



**IT IS MANDATORY TO COMPLETE THIS PROCEDURE FOR A TOTALLY SUCCESSFUL INSTALLATION. IF THIS PROCEDURE IS NOT FOLLOWED, THE X-RAY BEAM WILL NOT BE PROPERLY ALIGNED WITH THE DETECTORS.**

**Note** 

*Perform this procedure before installing the L-Block Covers and the Tube Support Covers.*

**Note** 

*To successfully complete the X-Ray Tube levelling procedure, the Rail System must be correctly level. Check that Rails are properly installed and level (refer to Section 2.2. Longitudinal Rails Unpacking and Installation and Section 2.5. Transverse Rails and Main Assembly Installation).*

**Note** 

*To complete this procedure, the Suspension must be Switched On and placed in the center of the room.*

#### **REQUIRED ELEMENTS**

- Allen Wrench Set
- Level
- Marking elements as chalk or an adhesive tape
- Sealing Wax or any other similar locking product.

## ADJUSTING POINTS LOCATION

The Tube leveling adjusting points are:

- a. **Alpha/Beta Axis Adjustment.** Check the proper adjustment of the Alpha Axis with the Beta Axis. If both axes are not correctly adjusted.
- b. **X-ray Tube.** Check the proper adjustment of the X-ray Tube.

**Illustration 2-78**  
**Tube Leveling Adjusting Points**

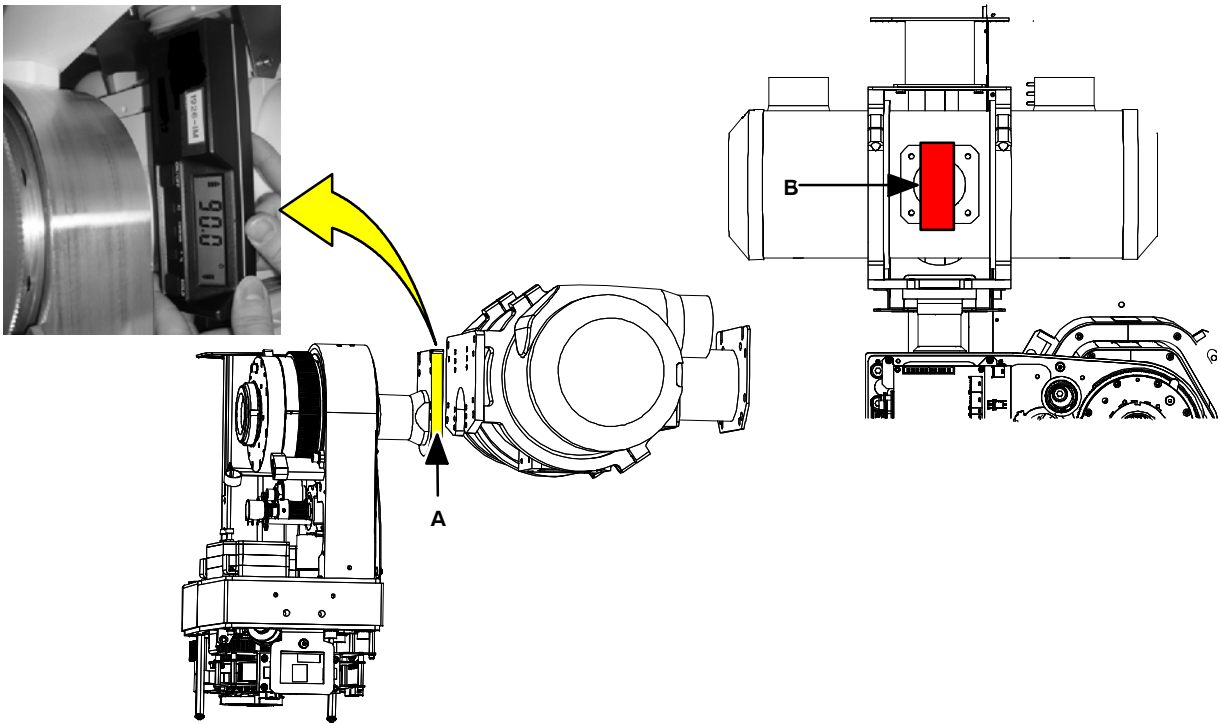

1. Rails System. Verify the leveling of the longitudinal and Transverse rails of the Ceiling Suspension. **They should be at  $0^\circ \pm 0.1^\circ$ .**
2. Adjust the Alpha/Beta Axis first. Put the level on the bottom surface of the Tube Adaptation Kit, on Adjusting Point **A**. It should be at  **$0.2^\circ \pm 0.1^\circ$**  over the horizontality to compensate the extra deformation when Collimator and cables are installed.

3. Loosen or tighten the Adjusting Screws located at the bottom of the Alpha Axis.

**Illustration 2-79**  
**Adjusting Screws**

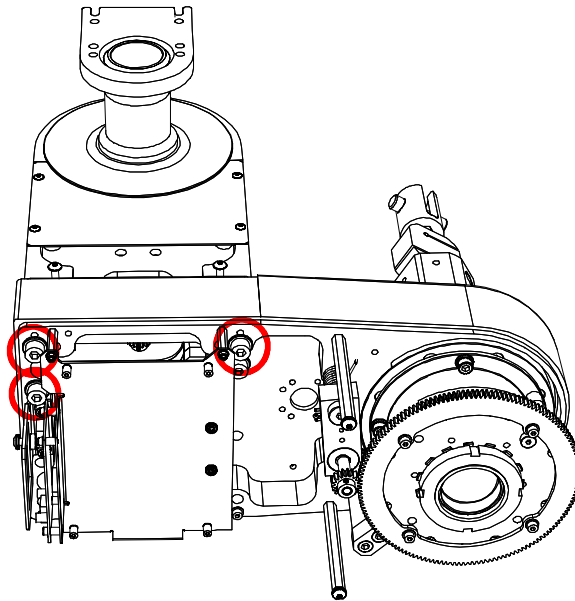

4. Adjust the X-ray Tube. Put the level lengthwise on the mounting surface of the Tube, Adjusting Point **A**. It should be at  $0.2^\circ \pm 0.1^\circ$  over the horizontality to compensate the extra-deformation when Collimator and cables will be installed.
5. Loosen or tighten the Tube Support Holder screws to fit better the Tube with the Tube Holders. Move the Tube if required to fit it better too.

**Illustration 2-80**  
**Tighten or loosen to Adjust the X-ray Tube**

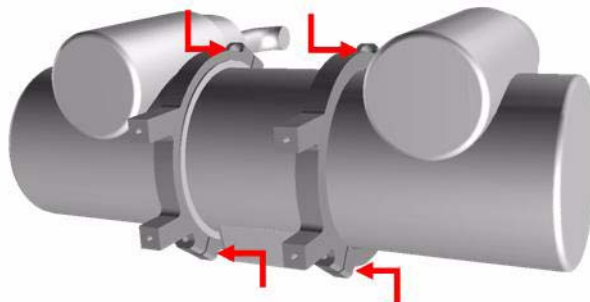

6. Check that the Collimator top surface is parallel to the bottom surface of the Tube Adaptation Kit.
7. Switch ON the equipment and the Collimator Light.
8. Mark on the floor with the adhesive tape or use the Collimation Test Tool to get a reference point.
9. Point the Collimator Light to this marked point.
10. Move up and down the Collimator light, it must point all the time to the marked reference point.
11. Once the Tube has been properly level proceed to calibrate the Suspension and finally to complete the whole System Installation and adjustment of the Suspension on regard with the other equipments of the room.

**Note** 

*Once the Collimator is installed it will be necessary to check again the X-ray Tube Leveling. But in that case it will not be possible to use the same adjusting Points.*

## 2.12 COLLIMATOR INSTALLATION

**Note** 

For detailed information related to Collimator Installation refer also to each Collimator technical documentation, provided with the equipment.

### REQUIRED ELEMENTS

The manufacturer provides a set of spacers and screws which are required for the installation of the collimator. Depending on the X-ray Tube and collimator combination the components of this set are:

**Illustration 2-81**  
**Ralco R225 Collimator**

Manual Collimator



Automatic Collimator



ADAPTATION KIT	HOUSING	COLLIMATOR BRACKET	SPACERS	FIXATION SCREWS
A11108-01	Toshiba E7239X/FX/GX Toshiba E7240X/FX Toshiba E7242X/FX/GX Toshiba E7299X Toshiba E7843X Toshiba E7865X Toshiba E7876X Toshiba E7884X Toshiba E7252X/FX/GX Varian Diamond 90°	Ralco R225 + Rotation Plate RO332 (15 mm / 0.59")	6 mm / 0.23" (x2)	DIN7991 M6x25 (x4)
A11109-01	Toshiba E7254 Varian Shapphire 90°		6 mm / 0.23" (x2) 1.5 mm / 0.05" (x2)	DIN7991 M6x25 (x4)
A11110-01	Toshiba E7100X Toshiba E7864X Toshiba E7867X Toshiba E7869X		6 mm / 0.23" (x1)	DIN7991 M6x20 (x4)
A11113-01	Varian B130_90° (A192/A292/G292)		1.5 mm / 0.05" (x2)	DIN7991 M6x25 (x4)
	Comet DO-7 / DO-9 / DO-10 Maxiray Mx75-09R IAE Tubes		Variable	Variable
A11113-02	Varian B199_90° (SG-292, SG-296, SG-1096)	Special Plate S0016272	NO	DIN 912 M5x20 (x4)

## 2.12.1 RALCO R225 COLLIMATORS

### INSTALLATION PROCEDURE

1. Open Packing Box F (Collimator) and N (Spacers and screws).
2. Assemble the X-ray Tube and Collimator Adaptation Ring by tightening its 4 screws to the Tube Support Holder.
3. Turn 135° the X-ray Tube to facilitate the Collimator installation if desired.

**Illustration 2-82**  
**Collimator installation**



4. Use the provided spacers and screws to fix the Collimator and adjust the correct distance with the Focal Spot. Check also the indications provided in the Collimator documentation and *Section 1.3 Pre-installation Checks*.

**Illustration 2-83**  
**Spacers and Fixation Points**

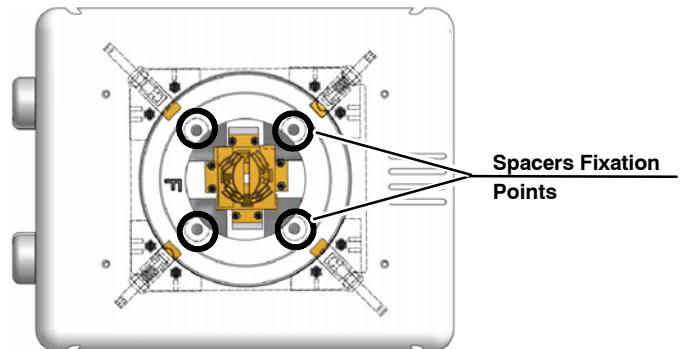

5. Mount the Collimator on the Ceiling Suspension as indicated in the collimator installation manual. Screw the four Allen screws as follows:
  - Position 1 & 3 = 6 <sup>1</sup>/<sub>2</sub> turns
  - Position 2 & 4 = 5 <sup>1</sup>/<sub>2</sub> turns

**Illustration 2-84**  
**Collimator Fixation Points**

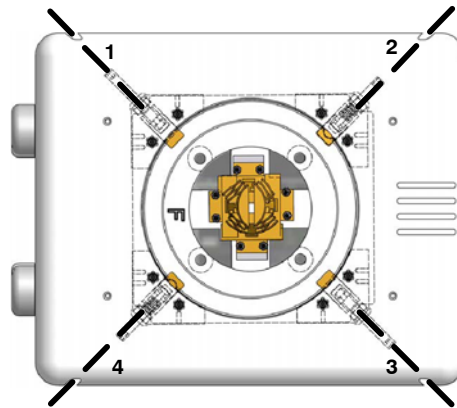

6. Connect the Collimator Cable. Remove the Collimator back Cover.

**Illustration 2-85**  
**Collimator Connection**

**Manual Collimator**

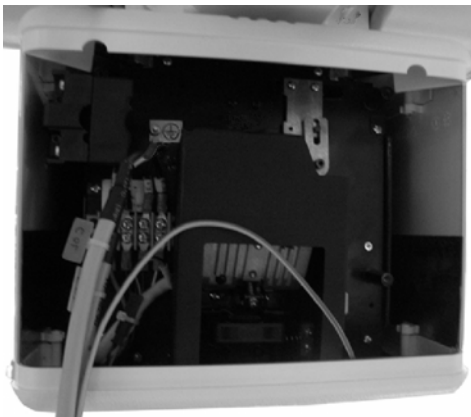

**Automatic Collimator**

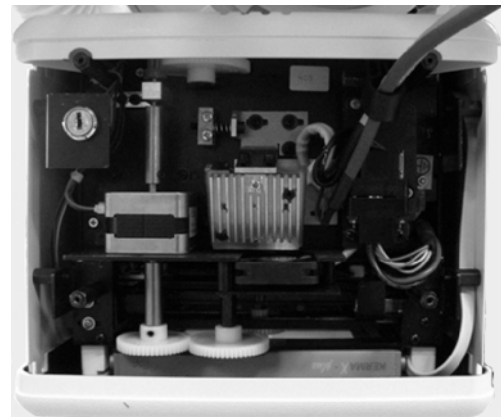

7. To check whether it is properly fixed, try pulling and shaking it.
8. With the X-ray Tube at 0° position check that the collimator is properly level.

**Illustration 2-91**  
**FFd Cable Connection**

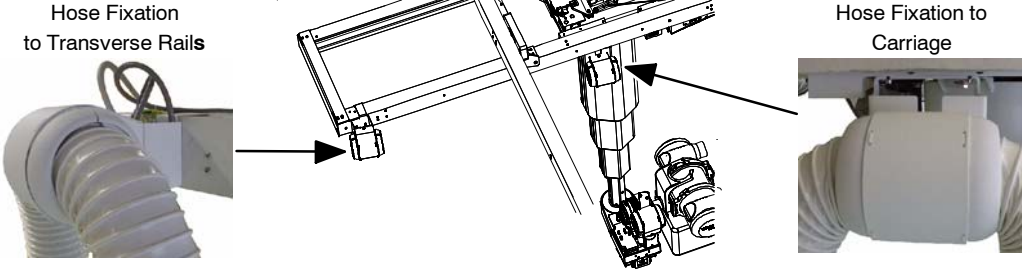

## 2.13 CONTROL CONSOLE INSTALLATION

### REQUIRED ELEMENTS

BOX	P/N	DESCRIPTION	QTY.
I	--	Handle Console (Steering Wheel Control Console)	1
	51212P66	Screw M6x16	4
	51390P12	Washer AET M6	4

### INSTALLATION PROCEDURE

1. Open the Packing Box I.
2. The console is packed already assembled. It is not necessary to split the Control Console to install it or to get it connected.
3. Assemble the console back cover with the Console Support that had been previously removed from the Tube Support Assembly.
4. Tighten the eight screws that fix the Console back Cover to the Console Support.
5. Once installed the External Hose, connect the Control Console.

**Illustration 2-97**  
**Control Console Installation and Connection**

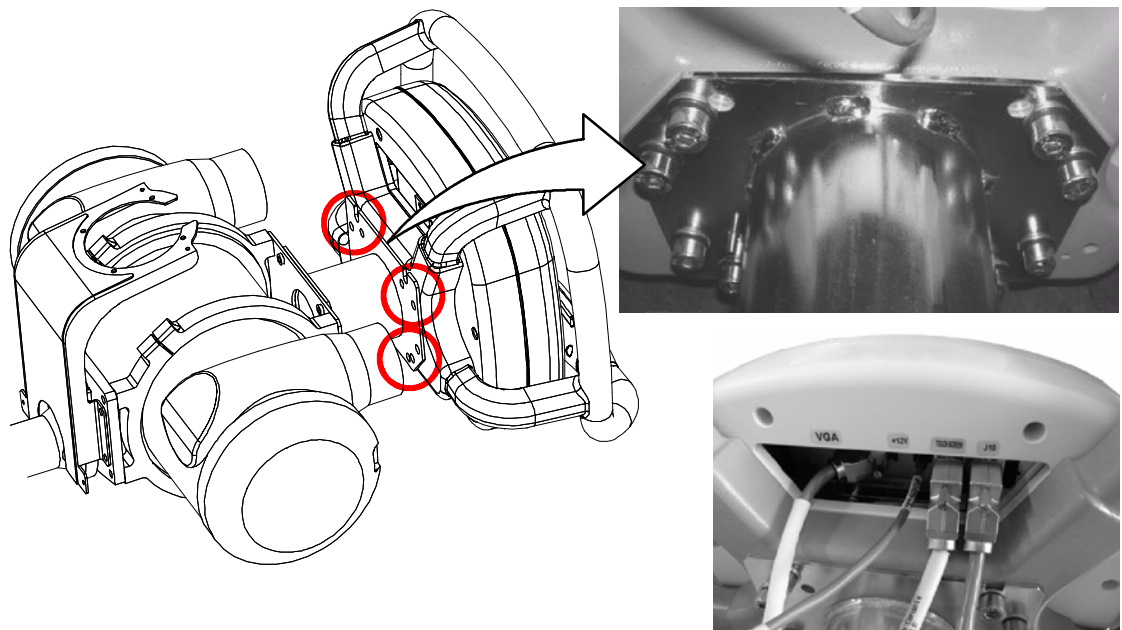

## 2.14 EXTERNAL HOSE INSTALLATION

### REQUIRED ELEMENTS

BOX	P/N	DESCRIPTION	QTY.
L	S0024163	Standard Hose Cables	1
	S0024164	Auto-tracking Hose Cables	1
	S0024135	Velcro Hose	1
	S0024136	Tubular Hose	1
--	S0004845	Wall Panel	1

### 2.14.1 EXTERNAL HOSES

Before routing and connecting all cables proceed to install the External Hose. There are two different options of Hoses for each Ceiling Suspension Model depending on the different available covers and fixation brackets:

- Tubular Hose With Rotation Tunnel Alpha, P/N S0024136.
- Velcro Hose With Rotation Tunnel Alpha, P/N S0024135.

The cables are the same and with the same connection, but the required distance between the Bracket-Cable Mounting to L-Block and the Hose Support Cover is different:

- For Tubular Hose it is 1260 mm (49.6")
- For Velcro Hose it is 600 mm (23.6")

Required Cables and connections are different depending on the Ceiling Suspension Model. Refer to the next Drawings for the detailed cables descriptions and connections (*refer to Section 2.16*):

- Standard Ceiling Suspension, S0024163 Hose
- Auto-tracking Ceiling Suspension, S0024164 Hose

The functions of the Hose Fixation brackets are to Support the External Hose and to provide cables entrance to the different connection points. Each cable will connect in a different connection point. These points are:

- **Y2** Connect ground cables to Transverse Rail (Axis Y).
- **Y1** Connect cables to Carriage.
- **L** Connect Cables to L-Block (Alpha/Beta Axes).
- **X** Connect cables to X-ray Tube, Collimator or Control Console.

**Illustration 2-98**  
**Hose Fixation Brackets**

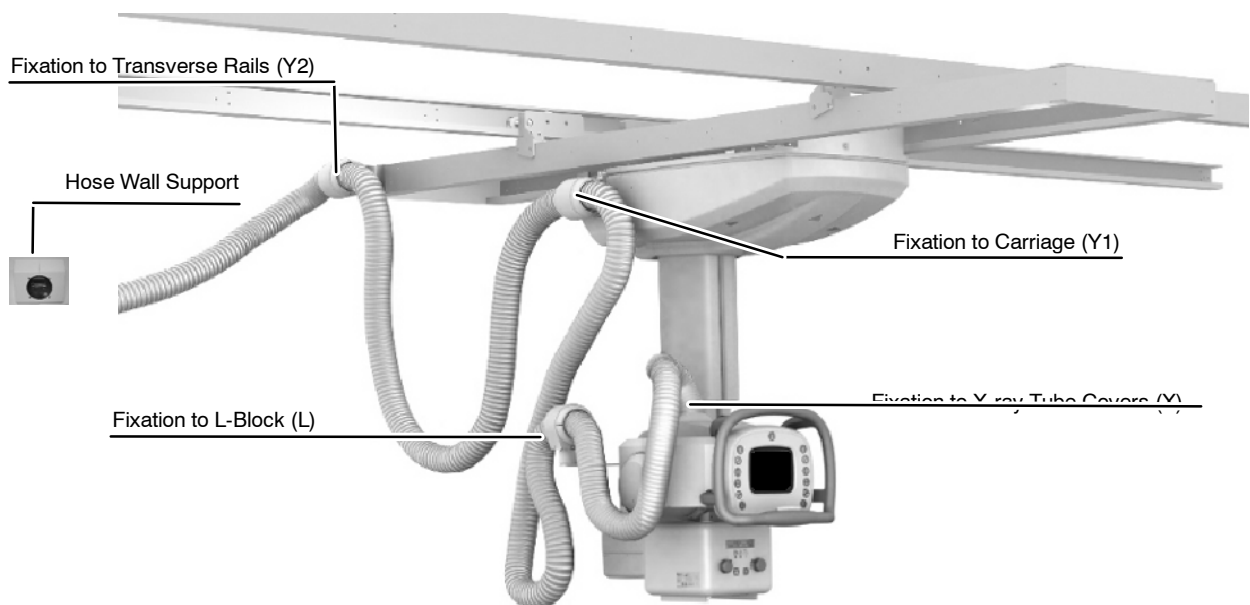

## 2.14.2 TUBULAR HOSE INSTALLATION

1. Prepare all the elements for the installation. Remove all shipping material and straighten out the twists in the cables before installing.

### Illustration 2-99

External Hose is shipped in the Main Crate

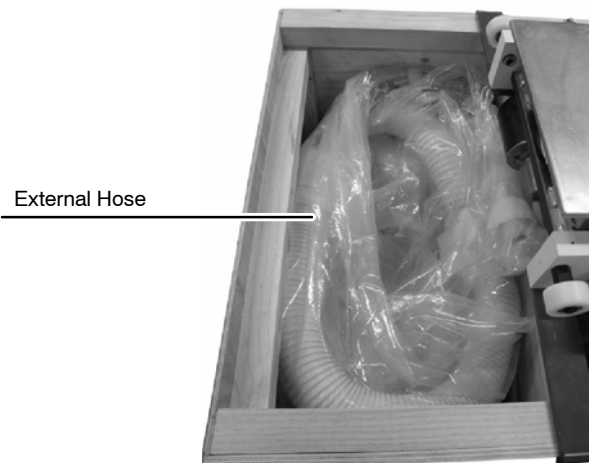

2. Stretch the Hose on the floor and place it in the same position where it will be installed. Check the distances on *Illustration 2-115*.
3. Fix the Bracket-Cable Mounting to the L-Block. Tighten the two screws to the top of the L-Block. It is important to install the alpha cover before installing this bracket. If not, dismount the bracket for cover installation.

### Illustration 2-100

Bracket-Cable Mounting to the L-Block



4. Install the Hose Support Cover. Screw the Tubular Hose into the Hose Support.
5. Tighten the four fixing screws.

**Illustration 2-101  
Hose Support**

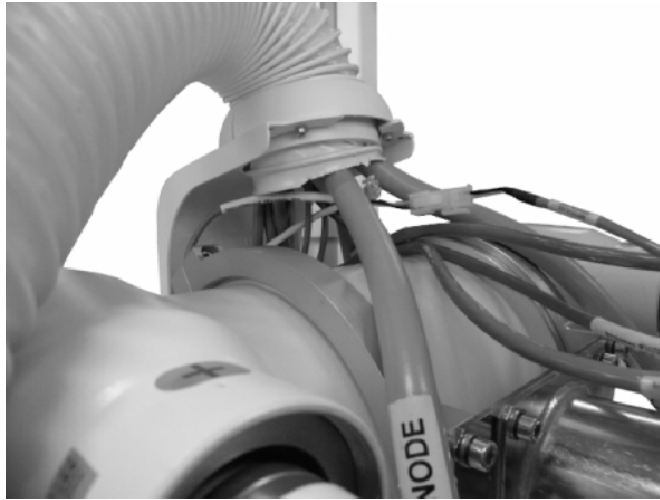

6. Fix the Bracket-Cable Mounting, P/N S0012040, to the Transverse Rails. Fit the Upper plate to the bridge and tighten the fixing screws to the Bridge.

**Illustration 2-102  
Bracket-Cable Mounting to the Transverse Rails**

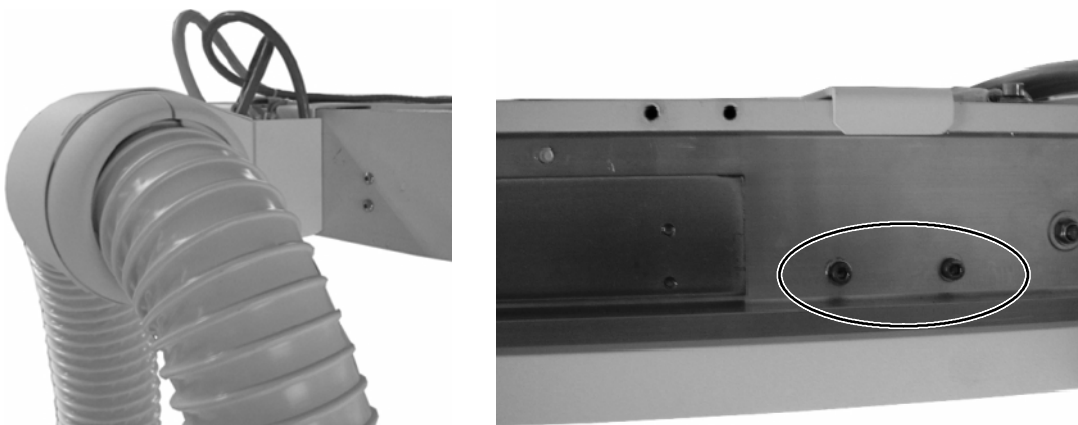

7. Fix the Bracket-Cable Mounting to the Carriage. Screw the hook of the Hose Bracket in the Carriage.

**Illustration 2-103**  
**Bracket-Cable Mounting to the Carriage**

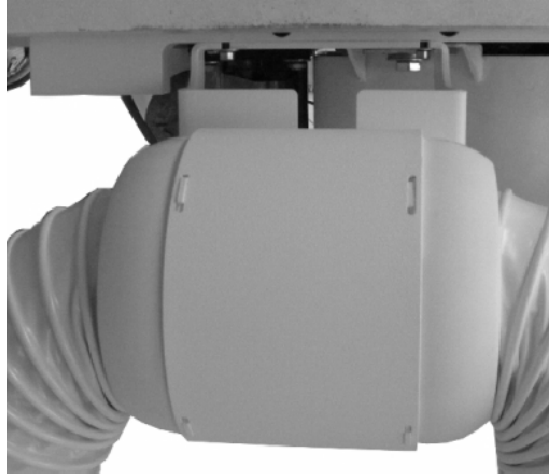

*Note* 

*Make sure that hose with cables to tube support is long enough to allow proper rotation movements of the tube.*

8. Fix the Hose Wall Support to the wall.
  - a. Route all cables along Electrical Ducts.
  - b. Install the Connection Support.
  - c. Install both Covers.

**Illustration 2-104**  
**Hose Wall Support Installation**



### 2.14.3 VELCRO HOSE INSTALLATION

1. Prepare all the elements for the installation. Remove all shipping material and straighten out the twists in the cables and the hose before installing.
2. Stretch the Hose on the floor and place it in the same position where it will be installed. Check the distances in *Illustration 2-115*.

**Note** 

*Make sure that Hose with cables to Tube Support is long enough to allow proper rotation movements of the Tube.*

3. Fix the Bracket-Cable Mounting, P/N S0020447, to the Bridge. Use the two holes located at the back of the Bridge. It is necessary to fix only the bottom of the Bracket with the two fixing holes.

**Illustration 2-105**  
**Bracket-Cable Mounting to the Bridge**

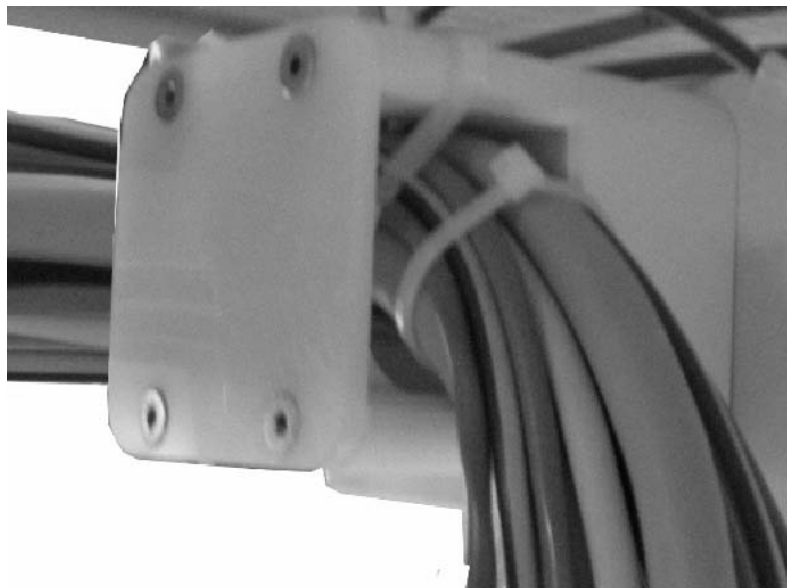

4. Install the Additional Hose Fixation, P/N S0021956. It must be located on the left Transverse Rail and fixed at the top of the rail. It is composed by:
  - S0021988 HOSE FIXATION \*
  - S0021989 HOSE TIE WRAP \*

5. Open Box 4, shipped in the Rails Crate, P/N S0019682CHK.
6. Fix the Hose Fixation Plate to the top of the left Transverse Rail. Use the next Items:
  - 51212P47 SCREW. M5x20 DIN912
  - 51380P27 WASHER B 5.3 AO DIN125
  - 51390P11 WASHER AET M5

**Illustration 2-106**  
**Hose Fixation to the Transverse Rails**

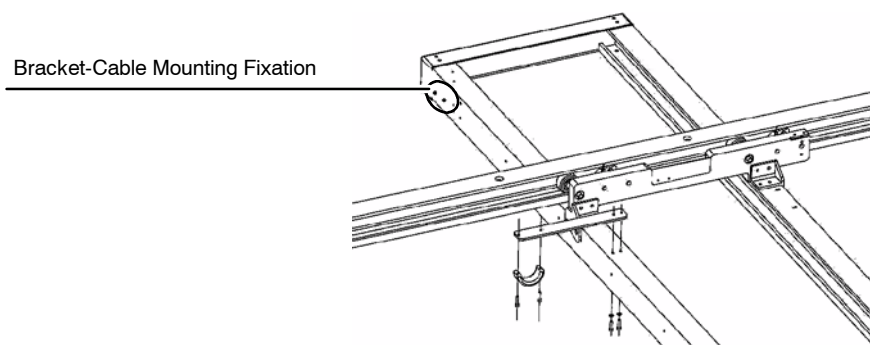

7. The Hose must be completely stretched from the Bracket to the Bridge.
8. Install the hose and fix it with the Hose Clamp. Use the next Items:
  - 51212P47 SCREW. M5x20 DIN912
  - 51390P11 WASHER AET M5
9. Fix the Bracket-Cable Mounting to the Carriage. Screw the hook of the Hose Bracket in the Carriage.

**Illustration 2-107**  
**Hose Fixation to the Carriage**



10. Fix the L-Block Hose Bracket. Tighten its two screws to the top of the L-Block. It is important to install the alpha cover before installing this bracket as it is not possible to install the cover after installing it without disassembling it.

**Illustration 2-108**  
**L-Block Hose Bracket**

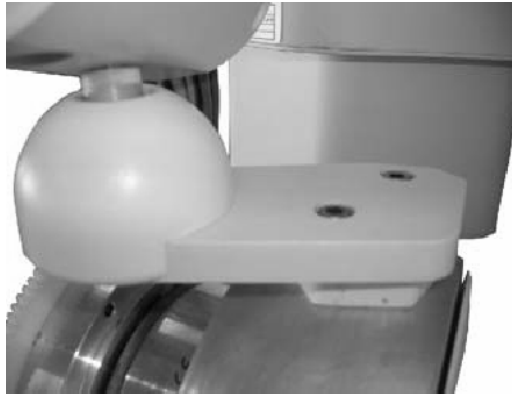

11. Open the Packing Box L. Use the Tie Wraps to fit properly the cables before being covered. Cover all cables with the cable Cover.
12. After installing the whole Hose, proceed to install the Hose Support on Tube.
13. Fix the Hose Cover Plate to the Hose Support left side. Fix the Cables Output Plate Statorix Tube Hose Support right side. Use:
  - 51212P23 SOCKET CAP SCREW M4X8 DIN912
  - 51380P26 FLAT WASHER B 4.2 AO DIN125
  - 51390P10 AET WASHER M4

**Illustration 2-109**  
**Hose Fixation to the Tube Support**

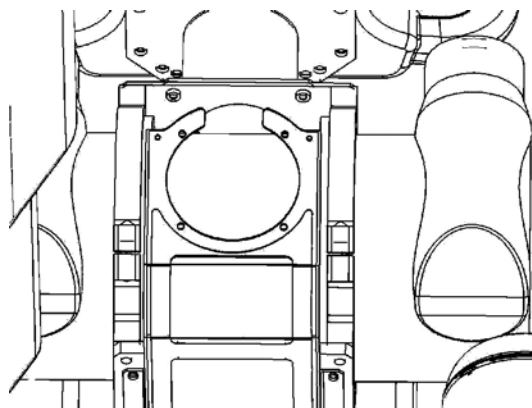

14. With the Tie Wrap, fix the Hose to the right side of the Hose Support. Get the Hose in its correct position, towards the left side.

**Illustration 2-110**  
**Use a Tie Wrap to fix the Cables**

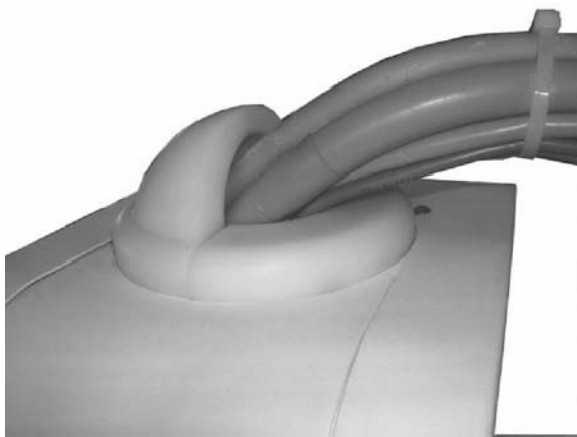

15. Fix the Hose Wall Support to the wall.

**Illustration 2-111**  
**Hose Wall Support**



## 2.15 CABLES



**TO COMPLY WITH THE REGULATIONS ON ELECTROMAGNETIC INTERFERENCES, THIS EQUIPMENT MUST BE USED IN SHIELDED AREAS, AND ALL INTERCONNECT CABLES TO PERIPHERAL DEVICES MUST BE SHIELDED AND PROPERLY GROUNDED.**

### 2.15.1 GENERAL OVERVIEW

There are different groups of cables, depending on the connections needed.

- Cables connecting the generator to tube are: HV cable, Stator cable, Ground cable.
- There are also other four Ground Cables. One of them links the Suspension to Earth source.
- Power cable for Collimator links it to the Suspension.
- Power cable for the Suspension links it to the 220V Power Supply.
- As an option there is also a SID Display kit which links the Suspension to the elevating table or Safety Parking Switch Table which links the Suspension to the tilting table.

Refer to *Illustration 2-114*. The cables distances are:

- **Y2 to Y1** is 2200 mm (86.61") or 2600 mm (102.36") for Transverse rails of 3500 mm (137.8").
- **Y1 to L** is 2150 mm (84.65")
- Distance **L to X** is:
  - 1260 mm (49.60") for Tubular Hose
  - 600 mm (23.62") for Velcro Hose

Output of the cables at the back of the bridge is always on the left. But cables can go either towards the right or towards the left of the cable guide rails.

#### Note

*In Position X, Illustration 2-115, cables could have different routing, some of them must be routed through the L-Block Tunnel and others directly to Console and Tube through the Hose Support.*

## 2.15.2 HV CABLE

Commercial reference of the HV is delivered as an option.

## 2.15.3 GROUND CABLES

In the hose there are five different ground cables, see the table below for their references. All are composed of the material 53314P74, whose description is Cable 5.37 AWG10 A/V UL1011 or UL1015 and its section is 5 mm<sup>2</sup>.

Ground Cables are:

- S0004387 Carriage Ground Cable
- S0005341 Tube Support Ground Cable
- S0016722 Generator Tube Ground Support
- S0024154 L-Block Ground Cable
- S0024155 Cable Console Ground Cable

**Illustration 2-114**  
**Ground Cables Routing**

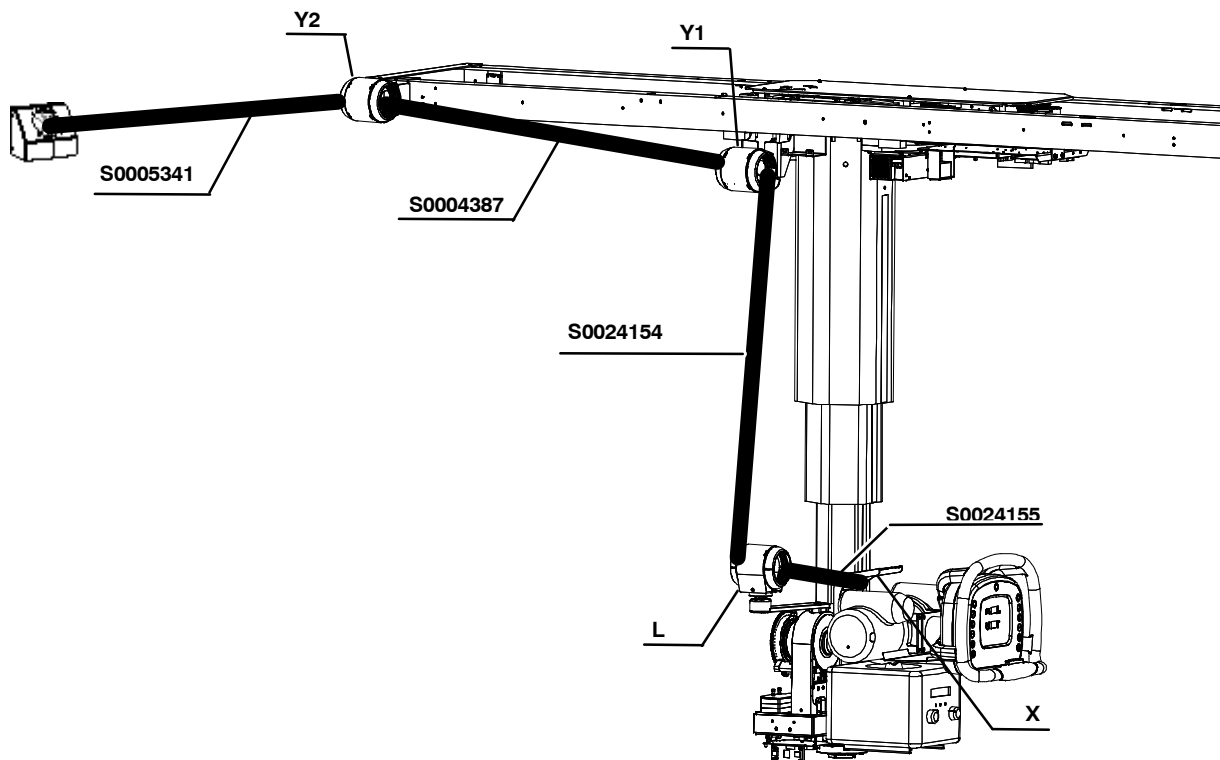

## 2.17 ALPHA/BETA DETENTS & X-RAY BEAM ADJUSTMENT

The Alpha and Beta mechanical Detents are factory adjusted at each 45°. However, they must be checked and if necessary corrected to get a proper Tube adjustment.

1. Switch ON the Ceiling Suspension.
2. Place on floor a collimation alignment tool. This tool must be aligned with the collimator light.

**Illustration 2-116**  
**Collimation and Beam Alignment Test Tools**

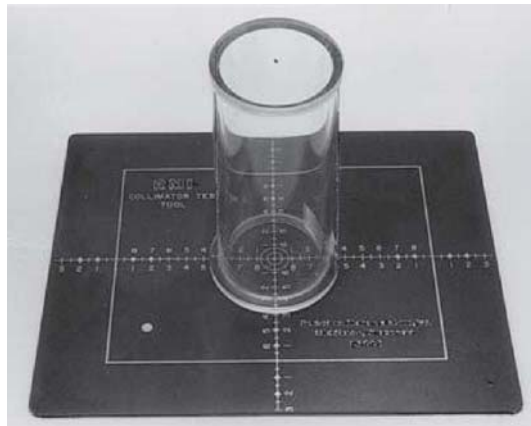

3. Move the Suspension up & down with the collimator light ON.

**Illustration 2-117**  
**Align and Move Up and Down to Check the Alignment**

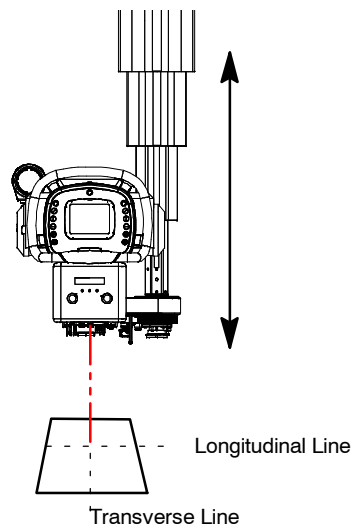

4. Verify that the light and the tool are aligned, and the light does not moves from the transverse and longitudinal lines.
5. Related to the Transverse Line, proceed to adjust the Alpha Detent.
  - a. The Alpha Detent is located behind the Collimator, turn the Tube at  $-90^{\circ}$  to get an easy access to the Detent.
  - b. Remove Alpha Detent Front Cover. Loosen the four fixing screws.

**Illustration 2-118**  
**Alpha Detent Location**

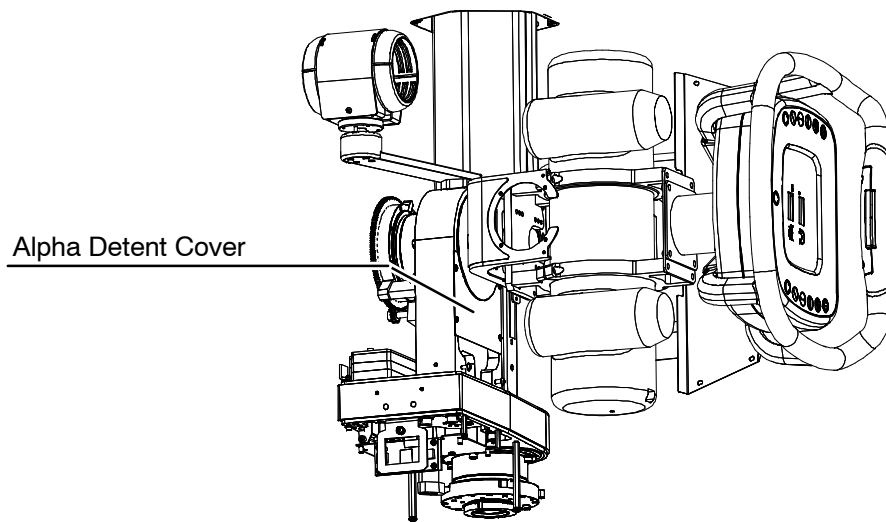

- c. Loosen or tighten the Adjustment Eccentric Screw of the Alpha Detent.

**Illustration 2-119**  
**Alpha Detent Eccentric Screw**

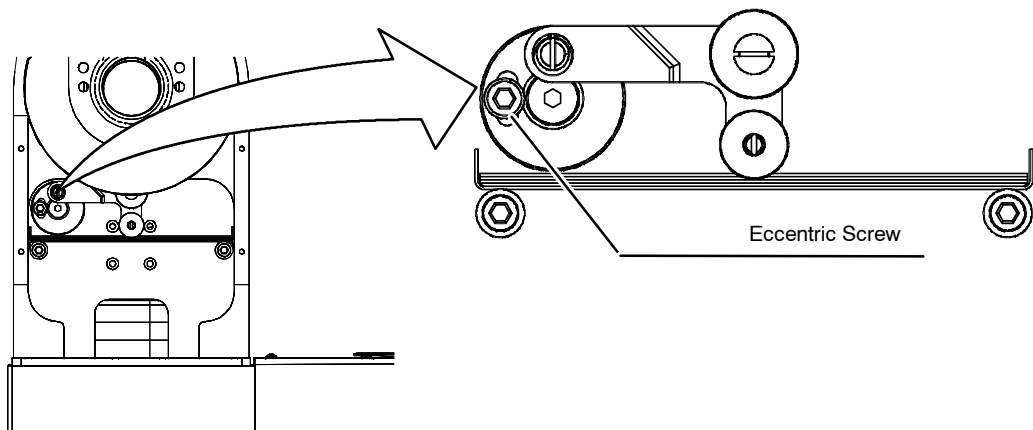

6. Related to the Longitudinal Line, proceed to adjust the Beta Detent.
  - a. The Beta Detent is located in the Beta Axis, between the Alpha Axis and the Telescopic Column.
  - b. Remove Beta Detent Cover. Loosen the fixing screws.

**Illustration 2-120**  
**Beta Detent Cover**

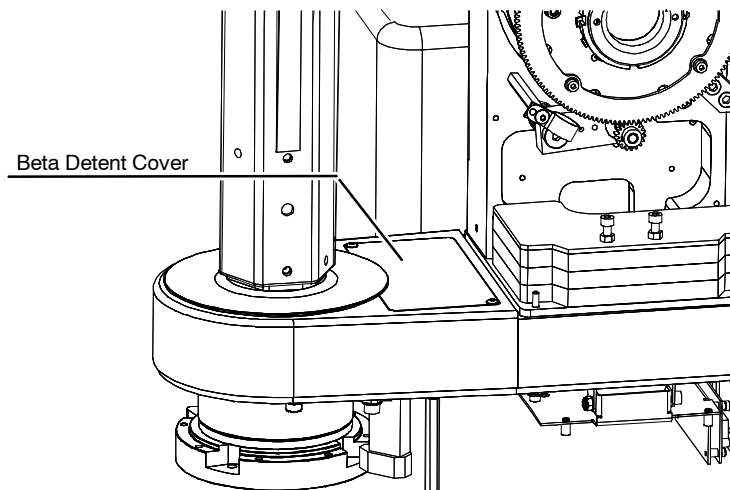

- c. Loosen or tighten the Adjustment Eccentric Screw of the Beta Detent.

**Illustration 2-121**  
**Beta Detent Eccentric Screw**

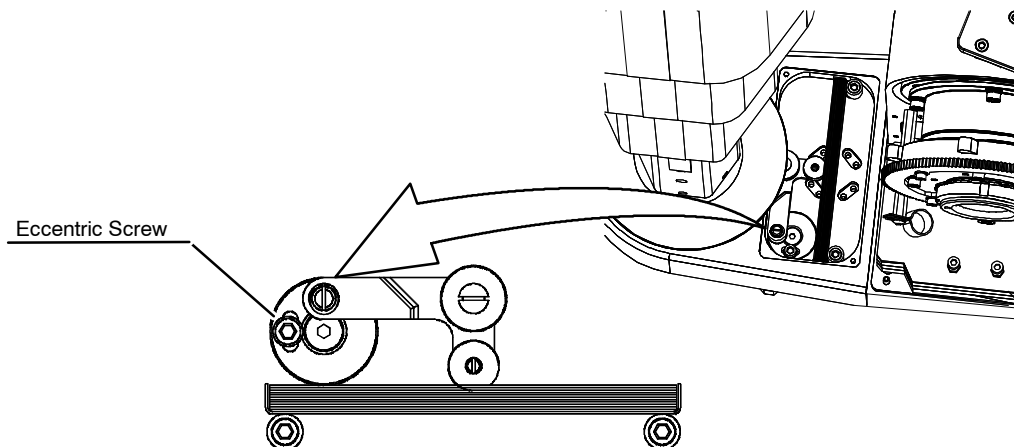

7. Check again if the Detents are adjusted.

## 2.18 COVERS INSTALLATION



**WARNING**

REMEMBER THAT IT IS REQUIRED TO PROCEED TO THE CONFIGURATION AND CALIBRATION PROCEDURE OF THE SUSPENSION BEFORE INSTALLING ALL THE COVERS OF THE L-BLOCK, INSTALL THE ALPHA COVERS JUST BEFORE THE GAGE CALIBRATION.

### 2.18.1 CARRIAGE COVERS INSTALLATION

#### REQUIRED ELEMENTS

BOX	P/N	DESCRIPTION	QTY.
N/A	S0007029	Carriage Back Cover	1
	S0007028	Carriage Front Cover	1
	S0009388	Support Bracket Cover	2
	51212P25	Socket Cap Screw DIN912 M4x12	4
	51390P10	Washer AET M4	4
	51380P46	Plate Washer	4
	51383P29	Big Washer 4.3	10
	S0004595	Button Head Screw DIN7380 M4x12	2
	S0005181	Button Head Screw DIN7380 M4x20	8

**Illustration 2-122**  
**Carriage Covers**

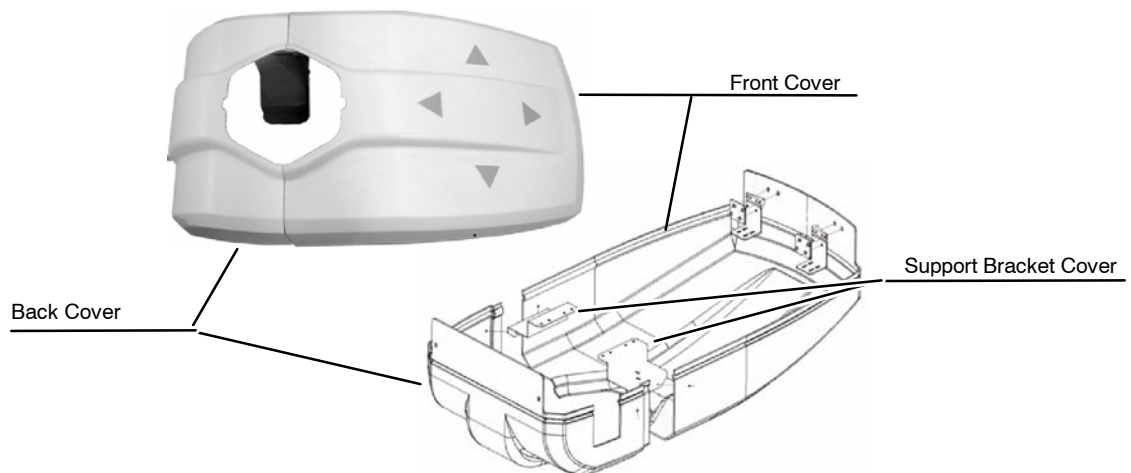

## INSTALLATION

1. Place the rear part of the carriage cover and fix it slightly using the two rear fixing screws. Do not tighten totally yet. Use:
  - S0004595 BUTTON HEAD SCREW DIN7380 M4x12
  - 51383P29 BIG WASHER 4.3

**Illustration 2-123**  
**Carriage Covers Installation**

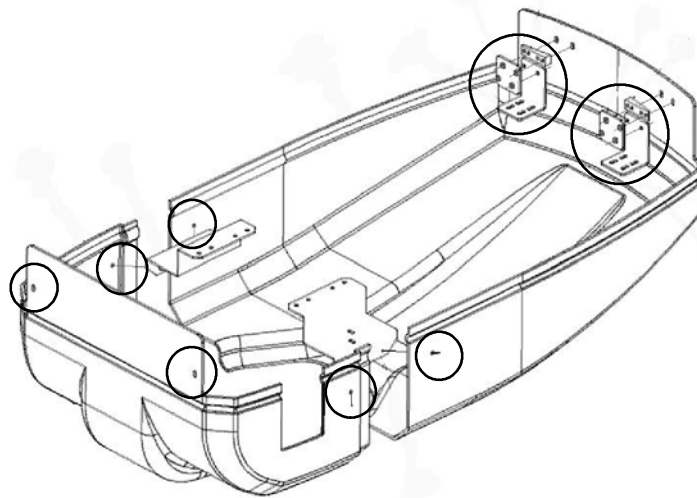

2. When a Tubular Hose has been installed, mount the Hose Support to Carriage. Just mount the Springs on the Carriage rear screws.

**Illustration 2-124**  
**Hose Springs Support**

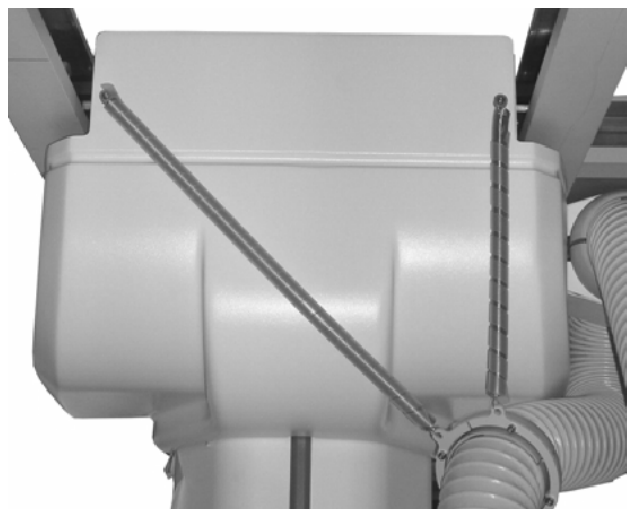

3. Place the front part of the carriage cover and tighten, but not totally yet, the four frontal fixing Screws, use:
  - S0005181 BUTTON HEAD SCREW DIN7380 M4x20
  - 51383P29 BIG WASHER 4.3
4. Both Covers must fit properly. Use the two lateral fixing screws to match both covers and the two Support Brackets. Do not tighten totally yet. Use:
  - S0005181 BUTTON HEAD SCREW DIN7380 M4x20
  - 51383P29 BIG WASHER 4.3
5. Once the Covers are completely installed and match correctly, tighten completely all screws.

### 2.18.2 TOSHIBA TUBES ADAPTATIONS COVERS INSTALLATION

1. Install the Hose Support Back Cover. Fix it to the Hose Support with the two fixing screws. Just when the installed collimator is digital and rotating.
2. Install the Tube Top Cover. Get the Cables ready to install properly the Tube Cover. Make sure that no cable gets damaged or rubbed.
3. Install the Bottom Cover. Fit it with the Tube Cover and fix it.

**Illustration 2-125**  
**X-ray tube top Cover**

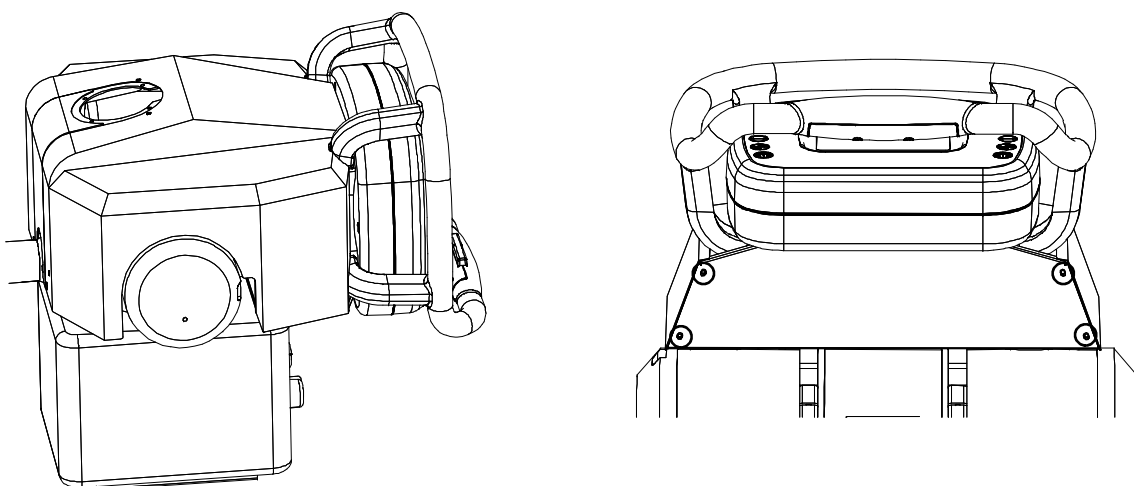

**2.18.3 L-BLOCK COVERS INSTALLATION**

**REQUIRED ELEMENTS**

BOX	P/N	DESCRIPTION	QTY.
N/A	S0024151	Alpha/Beta Tunnel Covers Assembly	1
	S0024189	Alpha Cover Assembly	1
	S0023200	Alpha cover Front Plate	1
	S0022745	Beta Cover Fixation Spacers	2
	S0023191	Beta Cover	1
	23902-01	Beta Cover Rear Support	1

**Illustration 2-126**  
**Alpha/Beta Tunnel Covers Assembly**

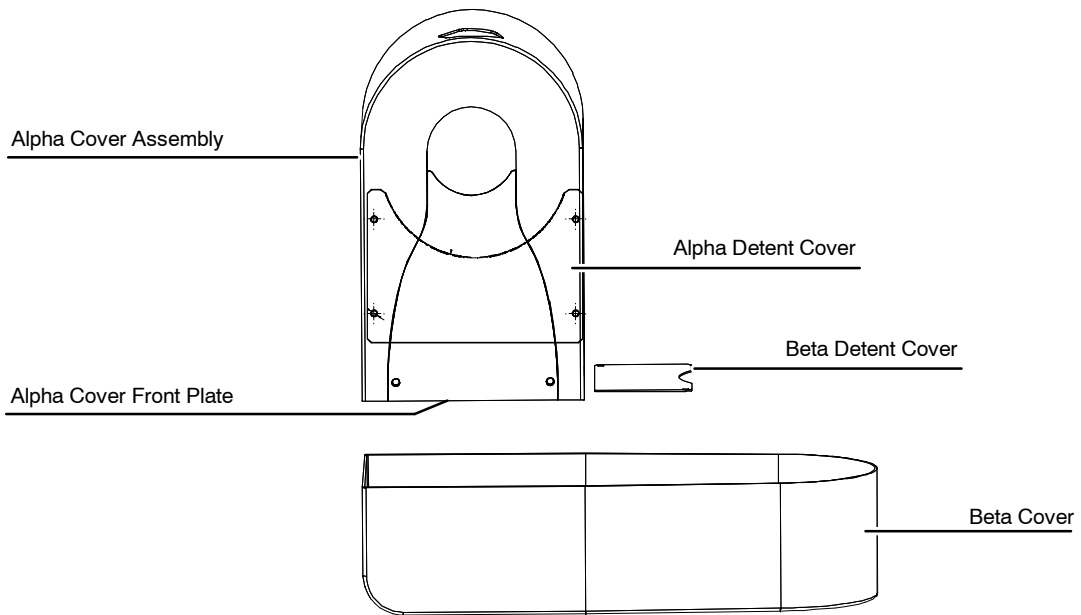

**Note** 

*There are two different sets of Alpha-Beta Covers, P/N S0024151, one for each axis. It is necessary to install first the Alpha and then the Beta Covers when the tube leveling procedure has been completed and checked again.*

## ALPHA COVERS INSTALLATION

1. It is mandatory to install them before the Hose installation, refer to *Section 2.14 External Hose Installation*, as the brackets must be installed with the Alpha Covers already installed.
2. Mount the Alpha Cover on Alpha Axis.

**Illustration 2-127**  
**Mount Alpha Cover**

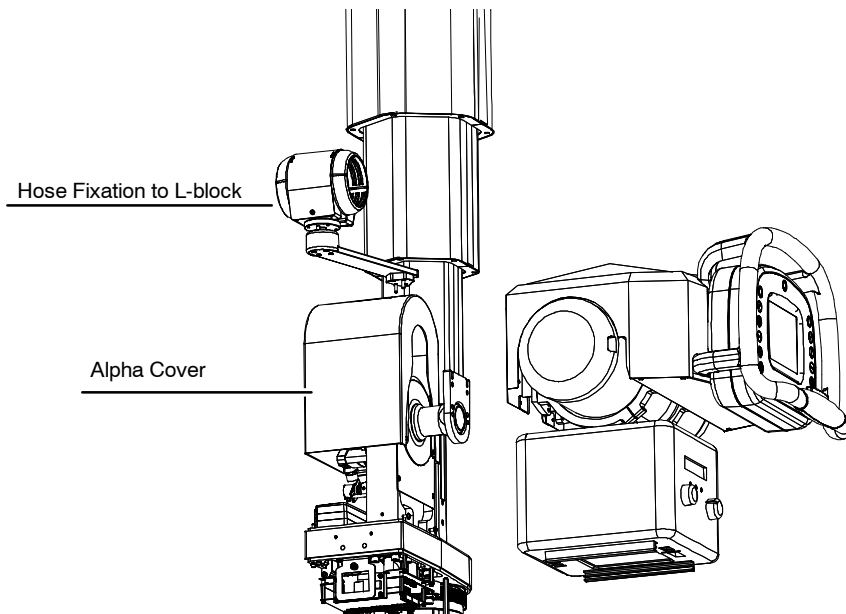

3. Install the Hose Fixation to L-block. Tighten both fixing screws to the top of the Alpha Axis.

**Illustration 2-128**  
**Fixing Points**

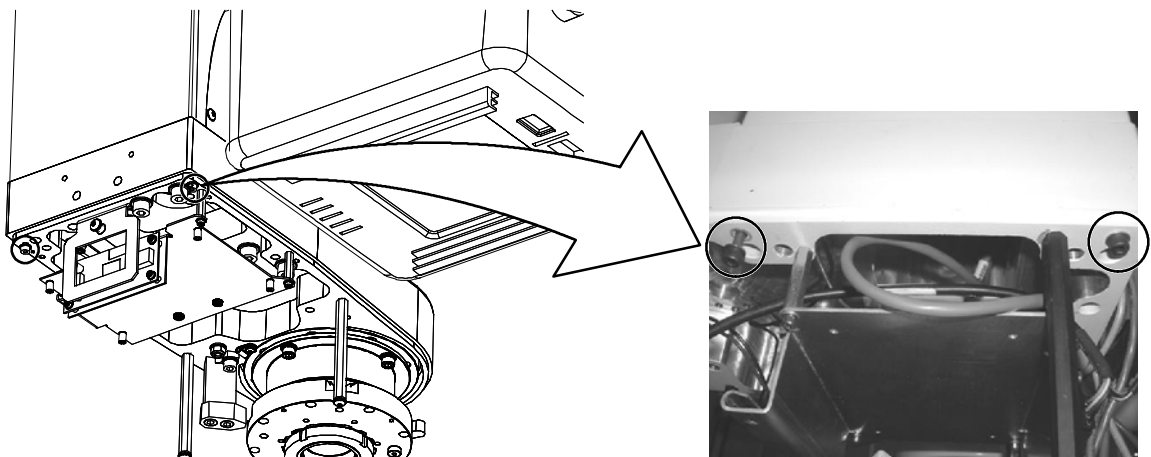

4. Adjust the Alpha Plate to the Alpha Cover. Tighten the front fixing screw and the two screws of the Alpha Plate Cover.

**Illustration 2-129**  
**Alpha Plate**

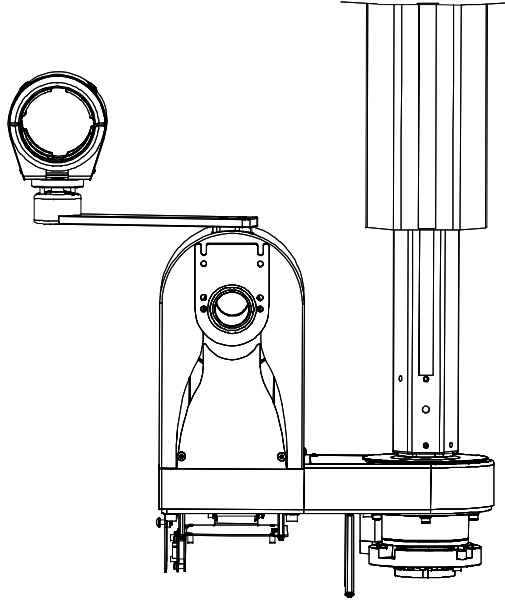

5. Tighten the lateral screw of the Alpha Cover.

**Illustration 2-130**  
**Alpha Cover Fixation**

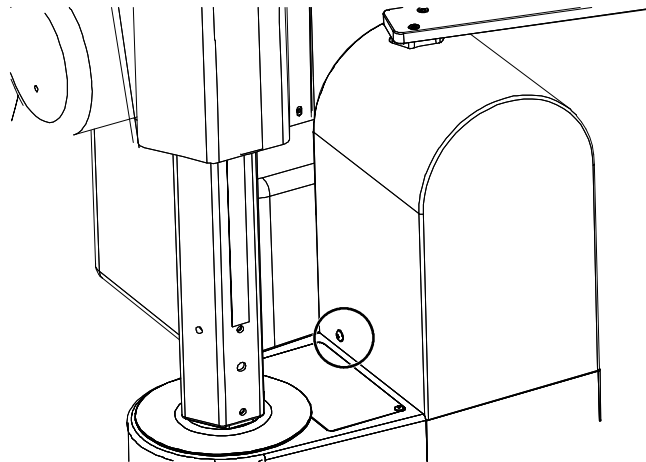

6. Fix the Alpha cover to the L-Block. Tighten the two screws that fix the cover located at the rear bottom of the L-Block.

### **BETA COVER INSTALLATION**

1. To install the Beta Cover just tighten the two screws which fix the cover to the Fixation Spacers, so they fix the cover to the L-Block.

**Illustration 2-131**  
**Beta Cover Installation**

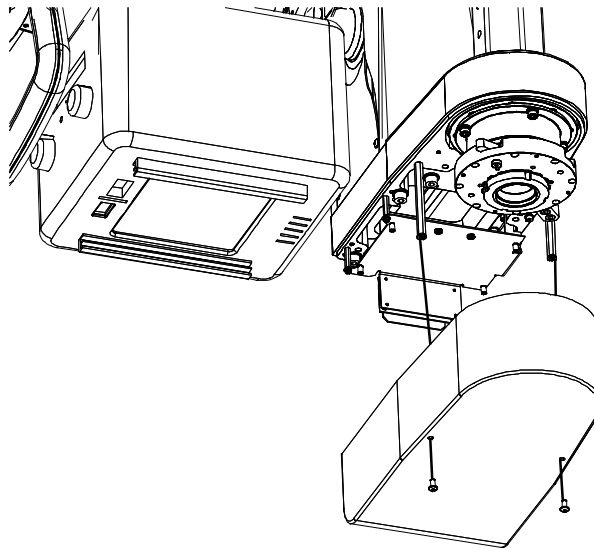

## GAGE CALIBRATION

The Gage board is located at the bottom of the column

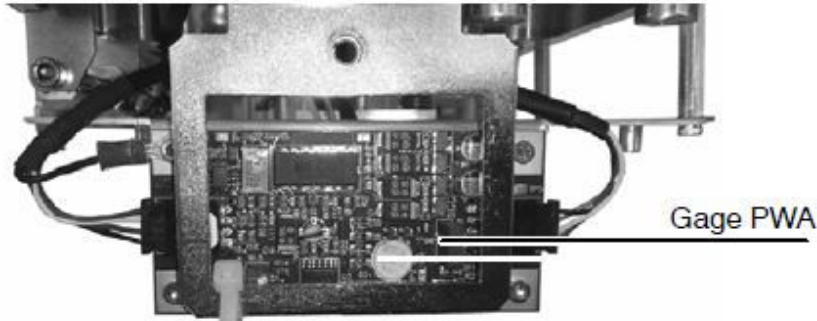
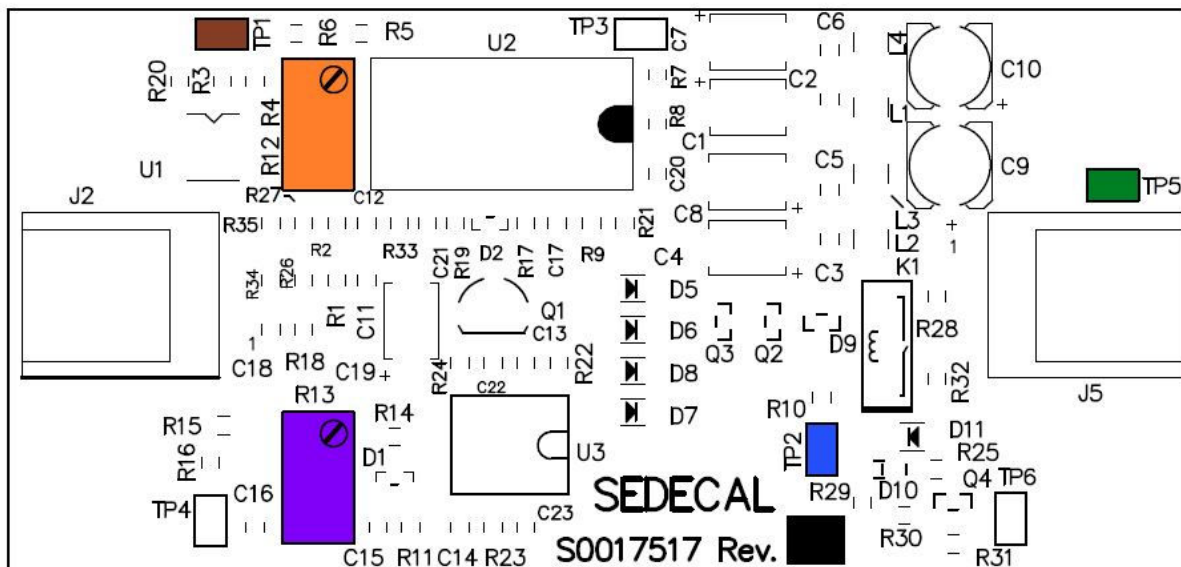

Illustration 4-28  
Load Cell Board Drawing (Same Orientation on Field)



**This calibration should only be performed after the column has been properly counterweighted and may need to be performed again after all covers have been installed.**

*This Section is valid for both Ceiling Suspensions models,  
Standard and Auto-tracking*

*The Gage is factory calibrated but it is recommended to check that  
during shipping and transportation has not been uncalibrated.*

1. Turn power on to the OTS

2. *Press the all locks release (located in the center of the handlebar assembly) briefly without applying up or down force on the handle and observe which direction the column wants to move*
  - a. *If the column does not move on its own proceed to step 3*
  - b. *If the column moves up, adjust R13 CW ¼ turn and retest. Repeat until the column remains stationary while the all locks button is pressed.*
  - c. *If the column moves down, adjust R13 CCW ¼ turn and retest. Repeat until the column remains stationary while the all locks button is pressed.*
3. *While holding the all locks button, adjust R13 CCW slowly until the column begins to move up and note the R13 position. Then adjust R13 CW until the column begins to move down and note the R13 position. You should set R13 to be in the middle of the 2 noted positions.*
4. *Test for equal effort for up and down motion.*

# CONFIGURATION AND CALIBRATION

This section describes the configuration and calibration procedure of the Standard Ceiling Suspension.

## OTS - Calibration for Standard Ceiling Suspension

Calibration steps to be performed for Standard  
M200 OTS

**1. Setup**

- 1.1
- 1.2
- 1.3
- 1.4
- 1.5

**3. Setup the DIGITAL LIMITS**

- 3.1
- 3.2
- 3.3

**4. Calibration of TABLE**

- 4.1
- 4.6

**5. Calibration of Wallstand**

- 5.1
- 5.4

OTS Carriage connections are detailed on the following page

# SYSTEM INTERFACE

WIRING DIAGRAM with Ralco Manual Collimator  
 DIAGRAMA DE CONEXIÓN para colimador Ralco manual

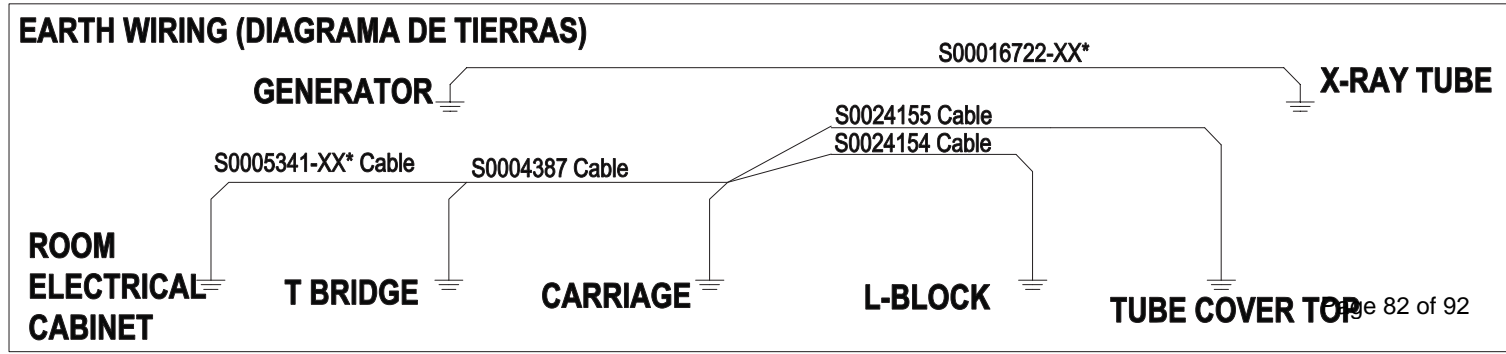
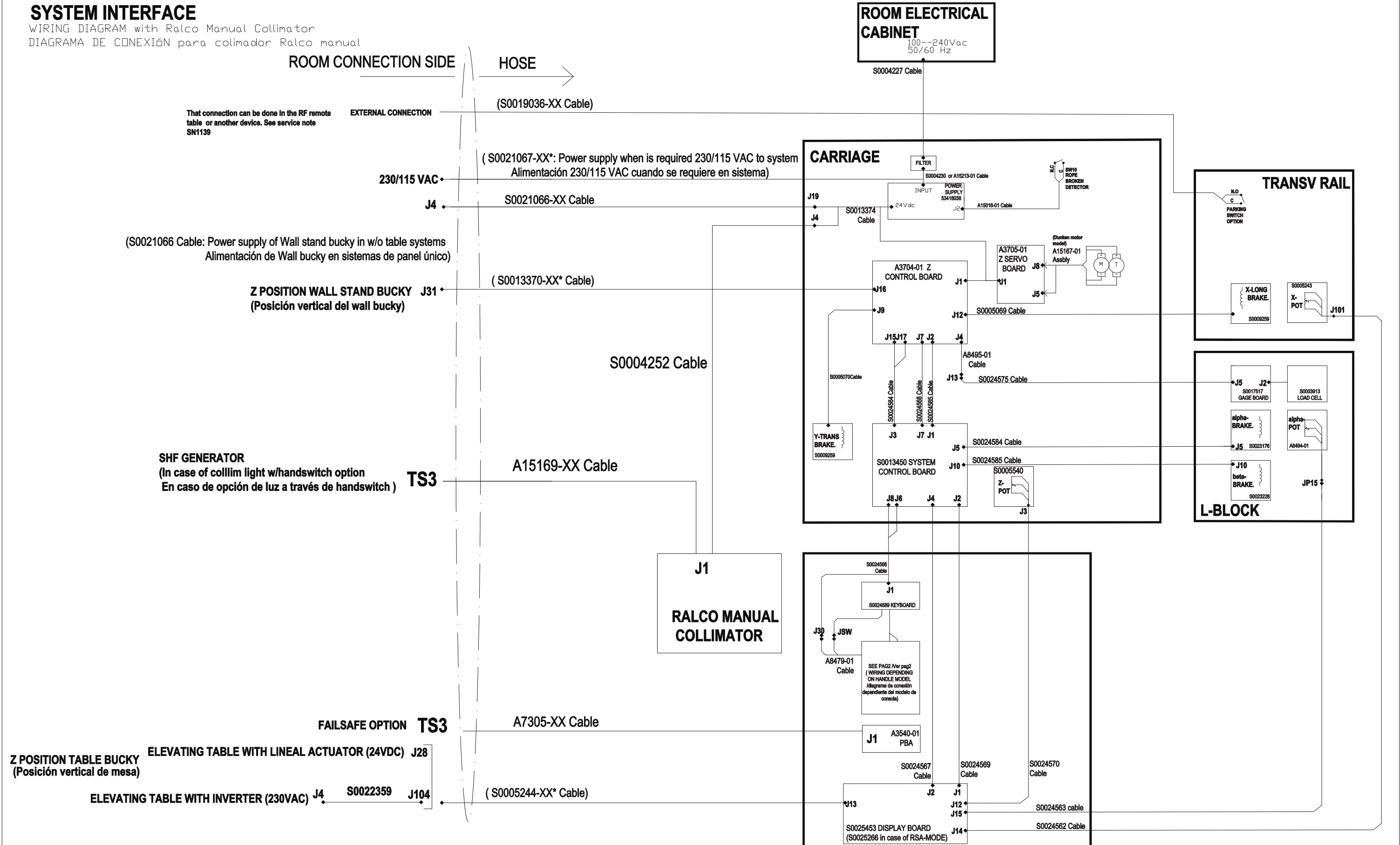

-XX\* Available in diferents lenghts  
 (-XX\* Cables disponible en diferentes longitudes)

REV	DESCRIPTION	ISSUED BY	DATE	NAME	DATE	SHEET / DF	S0024170_SCH			
□	NC 14/0480	SONIA PEREZ	18-11-2014	DRAWING	SONIA PEREZ	24-11-2010	1/2			
N	NC 14/0187	SONIA PEREZ	24-07-2014	REVISED	F.GARCIA	24-11-2010	D N L K ←			
L	NC 14/026	SONIA PEREZ	20-05-2014							
K	NC 14/039	SONIA PEREZ	04-04-2014							
REV	DESCRIPTION	ISSUED BY	DATE							

SEDECAL  
 AUTOTRACKING, P.T.C. W/ SENSING  
 Standard M200 Quickstart Guide  
 WIRING 108729-001 Rev. A

# Manual addendum for setup and calibration of standard OTS

**NOTE: This addendum supersedes the OTS manual for all setup and calibration. This addendum is only intended to be used with a Summit Table or Summit Wall-stand. If used with another manufacturers Table or Wall-stand please refer to the OTS manual for directions.**

## Tooling:

DC Voltmeter

Ohmmeter

1.5mm (0.059in) and 2.0mm (0.079in) slotted screwdriver

#2 stubby phillips screwdriver

Metric AND English tape measure

5x magnifying lens with built in flashlight (ex. Carson 5x part no: PO-55-P, Amazon )

Metric Hex keys (2, 2.5, 3, 4 mm)

Miniature Alligator clip set (Digkey: GC396-ND, need 6 clips)

small paper clips (2)

Blue Painters Tape, 2 in wide

## Procedure:

### 1. Setup

1.1. Shut off power to the NOVA tube-stand

1.2. Gain access to the NOVA control boards (see section 4.1 of Nova manual)

a) Note: It will make calibration easier to remove the entire cover (don't use the hinging feature).

b) The DISPLAY, Z-CONTROL, and SYSTEM CONTROL boards are detailed on the last three pages of these instructions.

1.3. Gain access to the Display board (see section 4.1 of Nova manual)

1.4. Set all the switches (of all three circuit boards) as described in the next page.

a) After completion of switch setup in the display board, use the 2 side screws (of 6 screws total) to temporarily reattach the display cover.

1.5. Place miniature alligator leads onto the following test points of the **Z-CONTROL** board.

TP1, TP3, TP5, and any grounding screw (used as 0VDC reference).

Note: These leads will be hanging during the entire time of calibration.

Strain relief the leads by taping them to nearby harness cables or else shorting to nearby components can occur.

### 2. Connections:

#### 2.1. Cables

a) Connect the NOVA to the wall-stand using the NOVA cable marked "Vertical Potentiometer Cable" (the cable connects to J16 of the **Z CONTROL** board).

b) Connect the NOVA to the table using the NOVA cable marked "Table Pot Cable" (the cable connects to J13 of the **DISPLAY** board).

Board/PWA: **DISPLAY**  
 S0025453/S0025266  
 Schematic:  
 DISPLAY SID Y ROTATION, S0025490

Board/PWA: **SYSTEM CONTROL**  
 S0013450/S00XXXX  
 Schematic:  
 NOVA SYSTEM CONTROL

Board/PWA: **Z CONTROL**  
 A3704-01/S0024910  
 Schematic:  
 PBA NOVA TRACKING SERVO Z CONTROL

<b>SW1</b>	<b>W.S. Position</b>
	Pos 1: W.S. at right of table
	Pos 2: W.S. at left of table

<b>SW2</b>	<b>Tube/Table Location</b>
	Pos 1: W.S. at left/right of table
	Pos 2: W.S. at front/back of table

<b>SW3</b>	<b>W.S. Position for Angulation</b>
	Pos 1: W.S. at left of table
	Pos 2: W.S. at right of table

<b>SW11</b>	<b>Table Type</b>
	Pos 1: Elevating
	Pos 2: Fixed

<b>SW12</b>	<b>Units Displayed</b>
	Pos 1: cm
	Pos 2: inch

<b>SW14</b>	<b>Manual/Auto Tracking</b>
	Pos 1: Auto
	Pos 2: Manual

<b>J11</b>	<b>Table Height Sensor (into J13)</b>
	Pos A: Any 3 pin potentiometer
	Pos B: Nova Custom Signal

<b>SW1: TABLE &amp; W.S. Autotrack stop position</b>					
<b>SID cm / inch</b>	<b>Switch</b>				
	<b>1</b>	<b>2</b>	<b>3</b>	<b>4</b>	
80 / 31.5	OFF	OFF	OFF	ON	
88.8 / 35.0	OFF	OFF	ON	ON	
<b>100 / 39.4</b>	OFF	OFF	ON	OFF	
111 / 43.8	OFF	ON	ON	OFF	
114 / 45.0	ON	OFF	OFF	ON	
120 / 47.2	OFF	ON	OFF	OFF	
125 / 49.2	ON	OFF	ON	OFF	
133 / 52.4	ON	ON	OFF	OFF	
140 / 55.1	ON	OFF	OFF	OFF	

<b>SW3</b>	<b>Table Type</b>
	Pos 1: Elevating (Pos 1 is toward SP1 beeper)
	Pos 2: Fixed

# NOVA TABLE and WALL-STAND Setup and Calibration

## 3. Setup the DIGITAL LIMITS (must be done for auto-tracking to work)

### **SW14 SHOULD ALWAYS BE IN POSITION 1**

#### 3.1. Setup

- a) Turn on power to tube-stand
- b) Set the tube to 0 degrees
- c) Make sure auto-tracking is OFF (see page 3 Illustration 6-5)
- d) Follow the steps below in the order specified.

#### 3.2. Tube-stand lower vertical limit

Note: This section references the **Z CONTROL** board for all measurements and settings

- a) Adjust **P2 CCW 10** full rotations.
- b) Slowly lower the tube-stand down to the floor until the tube-stand is stopped by the mechanical limits.
- c) Raise the tube-stand by 20 mm. Note: If the tube-stand will no longer move, check the position of SW14 in the display board.
- d) Adjust **P2 CW** quickly until LED **DS1** illuminates. Back off of potentiometer to make sure the LED turns off then slowly turn the potentiometer until it triggers the LED to illuminate again.

#### 3.3. Tube-stand upper vertical limit

Note: This section references the **Z CONTROL** board for all measurements and settings

- a) Adjust **P1 CW 10** full rotations.
- b) Slowly raise the tube-stand to the ceiling until the tube-stand is stopped by the mechanical limits.
- c) Lower the tube-stand by 20 mm. Note: If the tube-stand will no longer move, check the position of SW14 in the display board.
- d) Adjust **P1 CCW** quickly until LED **DS2** illuminates. Back off of potentiometer to make sure the LED turns off then slowly turn the potentiometer until it triggers the LED to illuminate again.

#### 3.4. Wall-stand minimum SID limit

Note: This section will make sure auto-tracking will not operate when SID < 90cm. This section references the **Z CONTROL** board for all measurements and settings

- a) Lower the tube-stand to about middle of the vertical travel.
- b) Set the tube to 90 degrees aimed toward the wall-stand.
- c) Set wall-stand SID to 90cm.
- d) Adjust **P6 10** full rotations **CW** for a **shoot right** (or **CCW** for a **shoot left**) wall-stand.
- e) Adjust **P6** quickly until LED **DS4** illuminates (turn **CCW** for a **shoot right** and **CW** for a **shoot left** wall-stand). Back off of potentiometer to make sure the LED turns off then slowly turn the potentiometer until it triggers the LED to illuminate again.
- f) Reduce SID to < 90 cm and make sure LED is OFF
- g) Increase SID to > 90 cm and make sure LED is ON

#### 3.5. Wall-stand lower vertical limit

Note: This step must be done to ensure auto-tracking works properly

- a) Lower the tube-stand to it's lowest position.
- b) Lower the wall-stand to it's lowest position.
- c) Turn on collimator cross hairs.
- d) Move the wall-stand to be 1 cm HIGHER than the tube-stand.
- e) Setup wall-stand physical limits to prevent the wall-stand from moving lower.

# NOVA TABLE and WALL-STAND Setup and Calibration

## 3.6. Wall-stand upper vertical limit

Note: This step must be done to ensure auto-tracking works properly

- a) Raise the tube-stand to it's highest position.
- b) Raise the wall-stand to it's highest position.
- c) Turn on collimator cross hairs.
- d) Move the wall-stand to be 1 cm LOWER than the tube-stand.
- e) Setup wall-stand physical limits to prevent the wall-stand from moving higher.

# NOVA TABLE and WALL-STAND Setup and Calibration

## 4. Calibrate the TABLE

### **SW14 SHOULD ALWAYS BE IN POSITION 1**

#### 4.1. Setup

- a) Tube-stand must be powered
- b) Make sure auto-tracking is OFF (see page 3 Illustration 6-5)
- c) Set the tube to 0 degrees
- d) Move the tube-stand between the table and wall-stand so that it is free to travel all the way to the floor (in case there is a mis-adjustment somewhere).
- e) Place masking tape on the bottom of the display to act like a hinge, then remove the 2 screws holding the display together.

#### 4.2. Potentiometer scale adjustment (Variable SID tables ONLY)

Note: This section references the **DISPLAY** board for all measurements and settings. Use J1 pin 3 as the 0VDC reference for all measurements below.

- a) Initial **R88** setup: Adjust **R88** until **TP8** is **0.0 +/- 0.1 VDC**
- b) Lower the table down until the table stops automatically.
- c) Measure (and write down) the distance from the table top to the floor in **cm** (DistanceBottom)
- d) Measure (and write down) the voltage at **TP7** to X.X precision (VoltsBottom).
- e) Raise the table up until the table stops automatically.
- f) DO NOT MOVE table from this position.
- g) Measure (and write down) the distance from the table top to the floor in **cm** (DistanceTop)
- h) Measure (and write down) the voltage at **TP7** to X.X precision (VoltsTop).
- i) NOTE: VoltsTop > VoltsBottom. If this is not the case, call technical support.

$$VoltsScale = \left[ \frac{DistanceTop - DistanceBottom}{VoltsTop - VoltsBottom} \right] \times 0.15 \times VoltsTop$$

- j) Calculate
- k) Adjust **R147** (CCW will increase the value) until **TP7** = VoltsScale (X.X +/- 0.1 VDC)

Example: 
$$VoltsScale = \left[ \frac{89.4 \text{ cm} - 64.8 \text{ cm}}{10.8 \text{ V} - (-0.2 \text{ V})} \right] \times 0.15 \times 10.8 \text{ V} = 3.6 \text{ V}$$

#### 4.3. Auto-tracking SID adjustment (Variable SID tables ONLY)

Note: The display will indicate the WRONG SID values during this section. This section references the **DISPLAY** board for all measurements and settings.

- a) Lower the table down until the table stops automatically.
- b) Remove any jumpers/meter's that are attached to the display board.
- c) Turn ON auto-tracking, and wait for tube-stand to automatically stop moving.
- d) NOTE: if the tube-stand goes all the way down to the floor, then SW3 of the Z-Control board may be in the wrong position.
- e) Move the tube-stand over the table (assuming the tube-stand stopped above the table-top).
- f) Adjust **R88** (CW will increase the value) until the **Tube to Film SID** is **40** inches (or whatever SID is desired). NOTE: the tube-stand will move automatically while the adjustment is being made.

# NOVA TABLE and WALL-STAND Setup and Calibration

## 4.4. Tube-stand vertical speed adjustment (Variable SID tables ONLY)

Note: This section references the **Z CONTROL** board for all measurements and settings.

- a) Adjust **P4 CCW 10** full rotations (P4 controls soft vs hard motor stop, CCW = soft).
- b) Adjust **P3 CCW 10** full rotations (Temporary set the UP speed to maximum)

Note: Make sure to adjust the tube-stand speed to be SLOWER than the table speed in the up and down directions. If the tube-stand is faster a jerking motion will occur.

### c) Adjust the **DOWN** speed (**P12**):

- Turn OFF auto-tracking (see page 3 Illustration 6-5)
- Adjust **P12** until **TP1** = -1.5 VDC
- Set the Table to its highest position
- Turn ON auto-tracking and wait for tube-stand to stop.
- Lower table to its lowest position, note if the tube-stand motion for a jerking behavior.
- REPEAT all of step c)) with the following change:
  - If tube-stand is jerking, slow down the table (adjust P12 toward -1.0VDC at TP1)
  - If tube-stand is not jerking, speed up the table (adjust P12 toward -2.0VDC at TP1)

### d) Adjust the **UP** speed (**P3**):

- Leave auto-tracking ON (see page 3 Illustration 6-5)
- Adjust **P3 CW 10** full rotations (temporarily slow down the UP speed)
- Set the Table to its lowest position
- Raise table and note its UP speed.
- Adjust **P3 CCW 1** full rotation at a time until the UP speed matches the down speed.

## 4.5. Displayed SID adjustment (Variable SID tables ONLY)

Note: Sections 4.2, 4.3, and 4.4 must be performed PRIOR to this section. This section references the **DISPLAY** board for all measurements and settings.

- a) Leave auto-tracking ON (see page 3 Illustration 6-5)
- b) Raise the table a few inches and wait for tube-stand to stop.
- c) Lower the table a few inches and wait for the tube-stand to stop.
- d) Adjust **R79** until the **Displayed SID** is the desired value exactly (ex. 40.0)

Note: The SID value will be different depending on which direction the tube-stand was moving when it comes to a stop. The SID from UP travel is < the SID from the DOWN travel.

- e) Use the 2 side screws (of 6 screws total) to temporarily reattach the display cover.

## 4.6. Displayed SID adjustment (FIXED SID tables ONLY)

Note: This section references the **DISPLAY** board for all measurements and settings.

- a) Adjust tube-stand until 40 SID is achieved.
- b) Adjust **R79** until the **Displayed SID** is 40.0
- c) Use the 2 side screws (of 6 screws total) to temporarily reattach the display cover.  
**Note:** If **R79** will not adjust low enough, adjust **R88** to bring it into range

# NOVA TABLE and WALL-STAND Setup and Calibration

## 5. Calibrate the WALL-STAND

### **SW14 SHOULD ALWAYS BE IN POSITION 1**

#### 5.1. Setup

- a) Tube-stand must be powered
- b) Make sure auto-tracking is OFF (see page 3 Illustration 6-5)
- c) Set the tube to 90 degrees
- d) Move the tube-stand between the table and wall-stand so that it is free to travel all the way to the floor.

#### 5.2. Potentiometer scale adjustment

Note: This section references the **Z CONTROL** board for all measurements and settings

- a) Initial **P7** setup: Adjust **P7** until **TP5** is **0.0 +/- 0.1 VDC**
- b) Lower the wall-stand down until it stops.
- c) Measure (and write down) the distance from the center of the wall-stand to the floor in **cm** (DistanceBottom)
- d) Measure (and write down) the voltage at **TP3** to X.X precision (VoltsBottom).
- e) Raise the wall-stand up until it stops.
- f) DO NOT MOVE wall-stand from this position.
- g) Measure (and write down) the distance from the center of the wall-stand to the floor in **cm** (DistanceTop)
- h) Measure (and write down) the voltage at **TP3** to X.X precision (VoltsTop).
- i) NOTE: VoltsTop > VoltsBottom. If this is not the case, call technical support.

j) Calculate

$$VoltsScale = \left[ \frac{DistanceTop - DistanceBottom}{VoltsTop - VoltsBottom} \right] \times 0.05 \times VoltsTop$$

- k) Adjust **P8** (CCW will increase the value) until **TP3** = VoltsScale (X.XX +/- 0.01 VDC)

Example:

$$VoltsScale = \left[ \frac{192.1 \text{ cm} - 41.0 \text{ cm}}{8.3 \text{ V} - (-0.4 \text{ V})} \right] \times 0.05 \times 8.3 \text{ V} = 7.2 \text{ V}$$

#### 5.3. Auto-tracking alignment

Note: This section references the **Z-CONTROL** board for all measurements and settings

- a) Turn ON auto-tracking, (see page 3 Illustration 6-5) and wait for tube-stand to automatically stop moving.

Note: If the auto-tracking LED's are red, then the following will need to be done:

- Make sure SID > 90cm
  - Set the tube to 0 degrees and then back to 90 degrees.
- b) Adjust **P7** (CW will make the tube-stand travel UP) until the wall-stand and tube-stand are aligned. NOTE: the tube-stand will move automatically while the adjustment is being made.

#### 5.4. Displayed SID adjustment

Note: Sections 5.2 and 5.3 must be performed PRIOR to this section.

This section references the **DISPLAY** board for all measurements and settings.

- a) Set SID to desired value (example 40 inch)
  - b) Gain access the display board (use tape as a).
  - c) Adjust R104 until the display shows 40.0 inches
- Note:** If you run out of adjustment before you reach 40in turn the pot the opposite direction, After it reaches 0in it will count down from 99in.

# DISPLAY BOARD

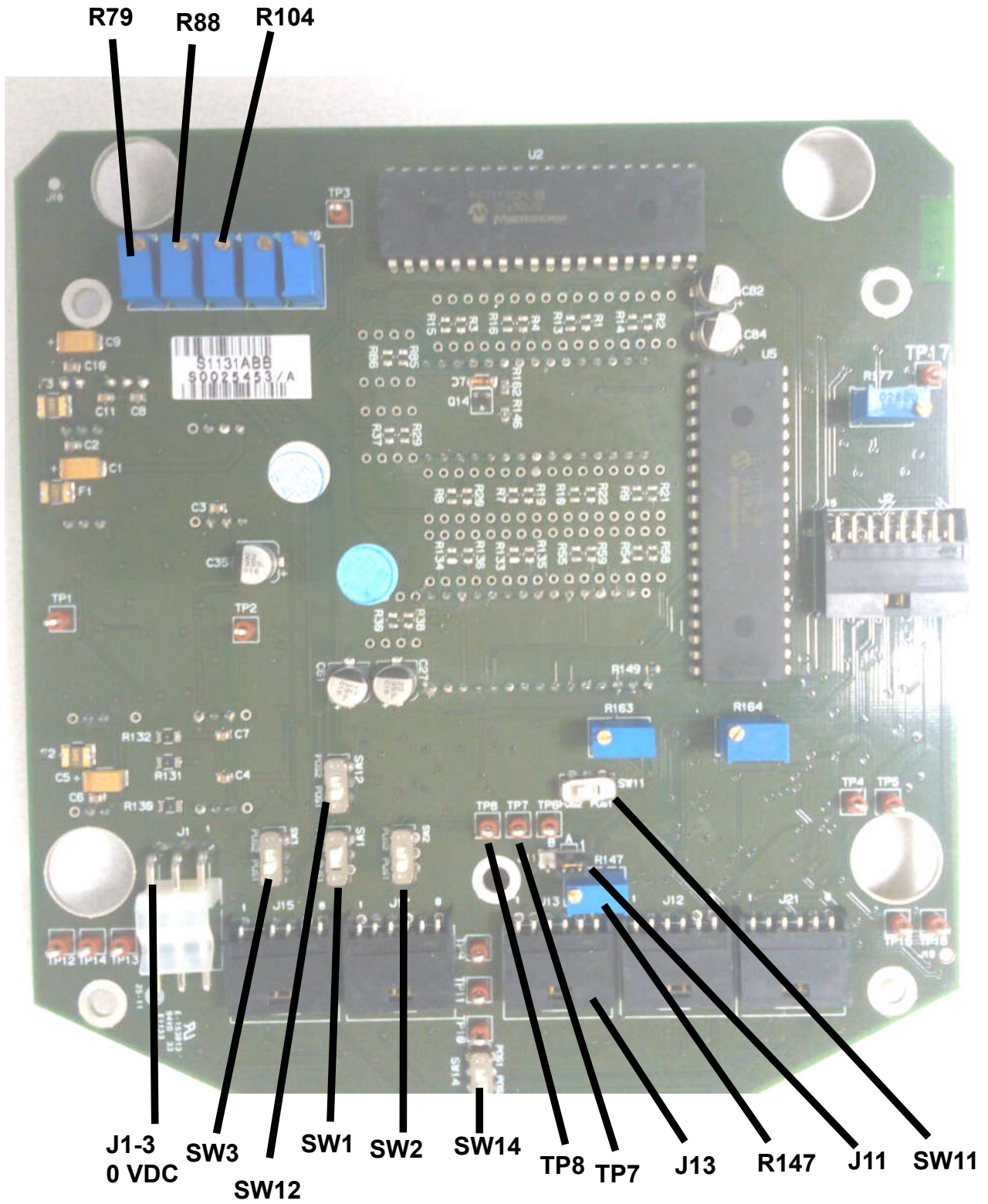

# SYSTEM CONTROL BOARD

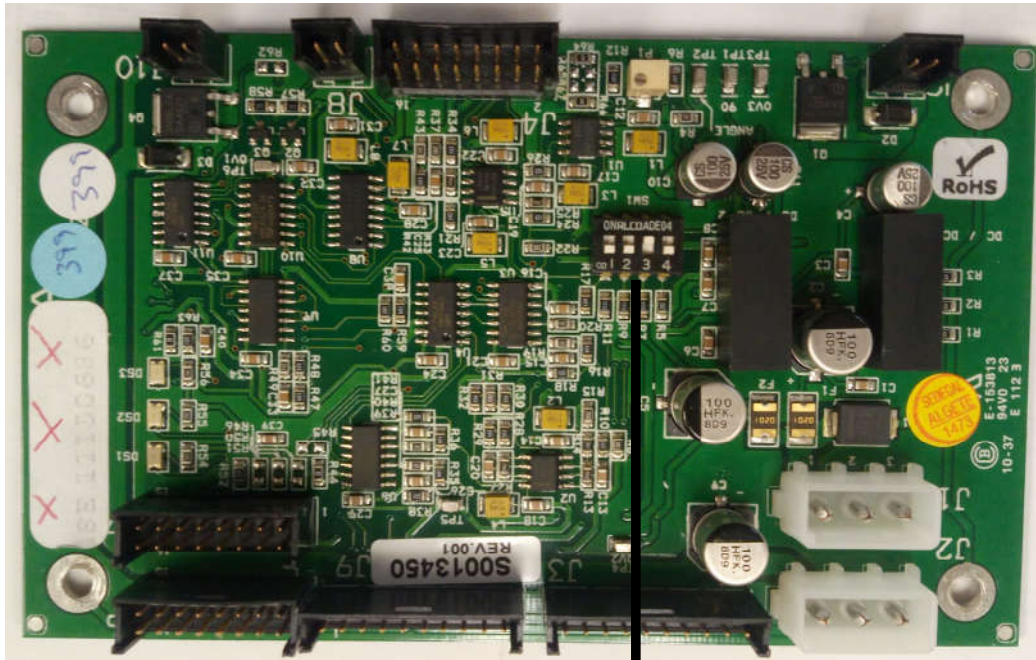

SW1

# Z-CONTROL BOARD

