

# **Floor Mounted Tubestand (FMTS)**

## **Installation & Users Manual**

**SUMMIT INDUSTRIES, LLC**  
7555 N. Caldwell Ave.  
Niles, IL 60714  
773-588-2444  
[www.SummitIndustries.net](http://www.SummitIndustries.net)

05654 Rev. H



### **WARNING**

#### **X-RAY EQUIPMENT MAYBE DANGEROUS TO BOTH PATIENT AND OPERATOR UNLESS PROPER SAFETY MEASURES ARE OBSERVED**

Though this equipment is built to the highest standards of electrical and mechanical safety, the useful X-ray beam becomes a source of danger in the hands of the unauthorized or unqualified operator. Excessive exposure to x-radiation causes damage to human tissue.

Adequate precautions must be taken to prevent unauthorized or unqualified persons from operating this equipment or exposing themselves or others to its radiation. Only qualified personnel should install, set up, maintain, and operate this equipment. Only qualified service personnel should remove electrical covers.

Before operation, persons qualified and authorized to operate this equipment should be familiar with the Recommendations of the International Commission on Radiological Protection, contained in Annals Number 26 of the ICRP, and with the applicable national and local standards.

The equipment described in this manual will perform reliably when installed, maintained and operated, in accordance with the instructions of this manual by qualified personnel. This equipment is sold with the understanding that the user assumes sole responsibility for radiation safety and that the manufacturer does not accept any responsibility for the following:

- Equipment improperly installed.
- Equipment improperly operated.
- Equipment improperly maintained or repaired.
- Equipment, which has been modified or altered in any way.
- Injury or damage to patient or other personnel for any of the above causes.

#### **Intended Use**

This is an x-ray Tubestand, a mechanical device intended to support and position an x-ray tube and collimator as required for radiographic procedures.



**CAUTION**  
**THIS MANUAL IS FOR USE BY**  
**PERSONNEL PROPERLY QUALIFIED TO**  
**INSTALL, MAINTAIN, AND OPERATE**  
**THIS EQUIPMENT.**

## 05654 Installation & Users Manual Revisions History

Revision	Pages Affected/Revision Description	Released Date
A	Released for Production	11-05-2010
B	Added Section 5.8 Vertical S.I.D. Monitor Switch Installation and Labeling	Aug. 2013
C	Update to floor rail with three tracks, rewrote maintenance section	Oct 2014
D	Updated 1.1 “J700 draws less than 1 Amp continuously” changed to “J700 draws less than 2 Amps continuously”; Removed 1.3; Replaced 1.2 with new Symbol Table.	Nov 2016
E	Replaced sections 5.7 and 5.8 with updated 5.7, 5.8, and 5.9, updated TOC; Update graphics on pg 9-3	ECR 9508 April 2017
F	Updated address to Niles, IL; Added “Intended Use” statement to sheet ii.	ECR 9600 June 2017
G	Fix incorrect floor rail hole callout in section 3.1.2	ECR 9845 March 2018
H	Removed Renewal Parts section	ECR 10431 February 2020

**TABLE OF CONTENTS**

<b><u>SECTION</u></b>	<b><u>TITLE</u></b>	<b><u>PAGE</u></b>
1	Description of Tubestand and Preparation for Installation .....	1 - 1
1.1	Classification Data .....	1 - 2
1.2	Precautions .....	1 - 3
1.3	Installation Location .....	1 - 4
1.4	Room Construction .....	1 - 4
1.5	Floor Preparation .....	1 - 4
1.6	Pre-Installation Wiring .....	1 - 4
2	Receiving, Storage, Unpacking and Handling .....	2 - 1
3	System Installation .....	3 - 1
3.1	Floor Rail Mounting .....	3 - 1
3.2	Column Installation .....	3 - 2
3.3	Mounting the X-Ray Tube, Angulation Box, Collimator and Continuous SID Monitor .....	3 - 5
3.4	Installing the Other System Components .....	3 - 8
3.5	Installing the High Voltage Cables .....	3 - 8
3.6	Tubestand Leveling and Adjustments .....	3 - 9
3.7	Tubestand Cables .....	3 - 10
4	Configuration .....	4 - 1
4.1	Electrical Configuration .....	4 - 1
4.2	Mechanical Configuration .....	4 - 1
5	Calibration .....	5 - 1
5.1	Small Room System Calibration .....	5 - 1
5.2	Transverse Arm Adjustment .....	5 - 1
5.3	Calibrating the Collimator Light Source to the X-Ray Field .....	5 - 3
5.4	Final System Alignment .....	5 - 5
5.5	Final Column Adjustments .....	5 - 5
5.6	Aligning the System Components .....	5 - 7
5.7	SID Labeling (standard kit 07845) .....	5 - 9
5.8	Horizontal SID Switch Installation (optional kit 07846) .....	5 - 11
5.9	Vertical SID Switch Installation (optional kit 07847) .....	5 - 17
6	Recommended Maintenance .....	6 - 1
6.1	Daily Maintenance .....	6 - 1
6.2	Scheduled Routine Maintenance .....	6 - 1
7	Diagnostics .....	7 - 1
7.1	Tubestand Lock, Failure, Switches, and Wiring Chart .....	7 - 1
7.2	Tubestand Lock Failure, Lock Coil .....	7 - 2
8	Drawings and Figures .....	8 - 1
9	Users Section .....	9 - 1
9.1	Controls .....	9 - 1
9.2	SID Markers .....	9 - 5

### **1. Description of Tubestand and Preparation for Installation**

This Floor Mounted Tubestand (FM Tubestand) is a moveable support system for the X-Ray Tube and Collimator. Refer to Figure 7, page 9-8, for components' identification. The unit can be used for all general purpose diagnostic techniques, and is composed of these major assemblies: the Floor Rail, the Floor Car, and the Column Assembly.

This FM Tubestand is certified to be compatible with all certified tube housing assemblies, X-ray controls, X-ray high voltage generators, cassette holders, and beam limiting devices. This Tubestand will not affect regulatory compliance of these components when these components are installed, connected, and adjusted in accordance with the applicable manufacturer's instructions and specifications.

## 1.1 Classification Data

This equipment is not suitable for use in the presence of a flammable anesthetic mixture with air or with oxygen or nitrous oxide.

Type of protection against electric shock is Class 1.



Degree of protection against electric shock is Type B.

Degree of protection against the ingress of water is IPXO / ordinary.

The function and intended application of this equipment is general radiography for human use.

Environmental conditions operation:

Temperature: 50° F to 104° F (10° C to 40° C)

Relative humidity: 10% to 95%, non-condensing

Atmospheric pressure: 20.67 inHg - 31.30 inHg (700 – 1060 hPa)

Environmental conditions for transport and storage:

Temperature: -40° F to 158° F (-40° C to 70° C)

Relative humidity: 10% to 100%, non-condensing

Atmospheric pressure: 14.76 inHg - 31.30 inHg (500 – 1060 hPa)

The FM Tubestand model J700 draws less than 2 Amps continuously.















The maximum support load rating of the tube arm (collimator and tube mass) is 70 lbs (32 kg).

The FM Tubestand complies with the following regulatory and design standards:

- UL 60601-1
- CAN/CSA C22.2 No. 601.1, CAN/CSA C22.2 No. 601.2.32-98
- X-RAY EQUIPMENT IEC 60601-2-32:1994



1.2 Definition of symbols used on the equipment

Symbol Legends	
Symbol	Definition
	Date of manufacture
	Manufacturer
	Serial Number
	Reference Number (Model/Part Number)
	Keep Dry
	NOTE This symbol represents Information that assists the user of the manual in the performance of a task. It may provide the user with better methods of conducting the task, or it may point out conditions that could cause the system to fail to operate properly.
 CAUTION	Points out special procedures, or precautions, that personnel must follow to avoid equipment damage.
 WARNING	Identifies situations or actions that may affect patient or user safety. Disregarding a warning could result in patient or user injury.
	TYPE B APPLIED PART This symbol indicates equipment providing a particular degree of protection against electric shock, particularly regarding allowable leakage currents and reliability of the protective earth connection (if present).
	This symbol indicates an Electro Sensitive Device is present which must be carefully handled to prevent damage to the device.
	ELECTRIC SHOCK HAZARD WARNING This symbol indicates an electric shock hazard.
	DANGER VOLTAGE This symbol indicates hazards arising from dangerous voltages.
	DIRECT CURRENT This symbol indicates a direct current source.
	PROTECTIVE EARTH TERMINATIONS This symbol indicates protective earth terminations in device.

### 1.3 Installation Location

Specific site information is not provided in this section, but it does provide installers with information needed to install the FM Tubestand in almost any situation. The tubestand should be installed and aligned with the walls as defined in the layout before the table or Wall Stands are mounted.

### 1.4 Room Construction

Conventional radiographic room construction should be used for areas where the tubestand will be installed. Consult the State Health Department and local Building Codes for specific radiation shielding requirements

### 1.5 Floor Preparation

The FM Tubestand Floor Rail must be level to within  $\pm 1/8$ " laterally (front to back) and  $\pm 1/32$ " longitudinally (left to right). This is normally accomplished by placing shims (*provided in the Installation Kit*) between the floor and the rectangular tubes on the bottom of the rail. These tubes are located directly below the two shiny metal strips at the front and back of the Floor Rail. If your floor is very uneven, it may be more convenient to level the floor with grout instead of using a large number of shims.

If the floor was not prepared for installation with  $3/8$ " anchor holes drilled to a depth of  $1-3/4$ " during pre-installation, then prepare the floor. Use the tubestand Floor Rail as a template for marking the position of the anchor bolts.

### 1.6 Pre-Installation Wiring

The FM Tubestand requires 120 VAC 50/60 Hz power from a designated power source that should be available in the room prior to installing the unit. If using a generator, consult the generator installation manual for power compatibility. The Collimator also requires a power cable from its power supply. For other accessories, refer to the data supplied with the option for the type and quantity of additional wiring.

## 2 Receiving, Storage, Unpacking and Handling

In order to minimize opportunity for damage, it is recommend the carrier be instructed to deliver the tubestand directly ("drop ship") to the installation site at time of installation if possible. If this is impractical, unpack the tubestand so that it can be inspected for concealed damage. Then repack it so that it can be transported to the installation site as originally shipped in its original shipping crate.

If it is necessary to completely or partially unpack and/or store the tubestand before delivery to the installation site, prevent rust and corrosion by ensuring it is stored at moderate temperatures in a dry location. Also, avoid stacking items on top of the unit during storage and make sure that it is well protected against damage during shipment.

### Unpacking

The tubestand is packed in two shipping crates. The Floor Car and the Tubestand Column are in one box, while the Floor Rail is in a second box. Thoroughly inspect the contents of each container for damage that may have occurred in transit. If damage is found, immediately inspect for concealed damage to other components. **A claim must be filed with the carrier within 5 days.**

To unpack the Floor Car and the Tubestand Column, proceed as follows:



#### CAUTION

**Several persons may be required to lift some of the heavier or bulkier pieces from the packing material, or when positioning them in place.**

Remove the banding from around the cardboard carton and lift off the cover.

The Floor Car is in a separate box inside the large carton. Remove this box and unpack the assembly.

Remove all remaining cushioning material.



#### WARNING

**DO NOT REMOVE THE COLUMN COUNTERWEIGHT LOCKING BLOCKS (APPROXIMATELY 1-1/2" X 1-1/2" X 5') OR VERTICAL SLIDE (1-1/2" X 1-1/2" X 5") AND SCREW UNTIL INSTRUCTED TO DO SO. REMOVING THESE BLOCKS AND SCREW WILL PERMIT THE WEIGHTS TO MOVE, DANGEROUSLY UNBALANCING THE COLUMN WHEN IT IS MOVED.**

## Model FM Tubestand

---

To protect the painted surfaces of the Tubestand Column, prepare a work area by positioning two blocks of wood, approximately 1-3/4" x 3-1/2" x 6" or longer, on the floor approximately 42" apart.

Lift the Tubestand Column from the shipping carton, and place it on the two wood blocks positioned in the preceding step.

### 3 System Installation

This section contains step-by-step instructions for the mechanical installation and assembly of the tubestand. The first installation step in this procedure is to mount the Floor Rail Assembly to the floor of the room. This is followed by raising the Tubestand on the Floor Rail.

#### 3.1 Floor Rail Mounting

The Floor Rail is the first component to be installed, and it must be aligned precisely with the walls and other components to ensure correct X-Ray beam alignment. The rail is equipped with rails which support and guide the Floor Car. It is attached to the floor by means of the five bolts, washers, floor anchors, and snap-in hole plugs supplied in the Rail Mounting Kit. *(Note - in some cases, this kit may be in a number of packages.)* Refer to Figure 1, page 9-2, for a list of kit components. If the supplied anchors are not suitable for your type of floor, use locally obtainable anchors to mount the rail. Use the following procedures to install the Floor Rail:

- 3.1.1 Refer to Figure 2, page 9-3, and to your room layout. Position the Floor Rail as shown in your room layout, maintaining the relationship between the Wall Stand (if used), the table, and the wall line. The table centerline and the Wall Stand centerline must all coincide to keep the X-Ray beam alignment within specifications. Orient the Floor Rail as shown below:

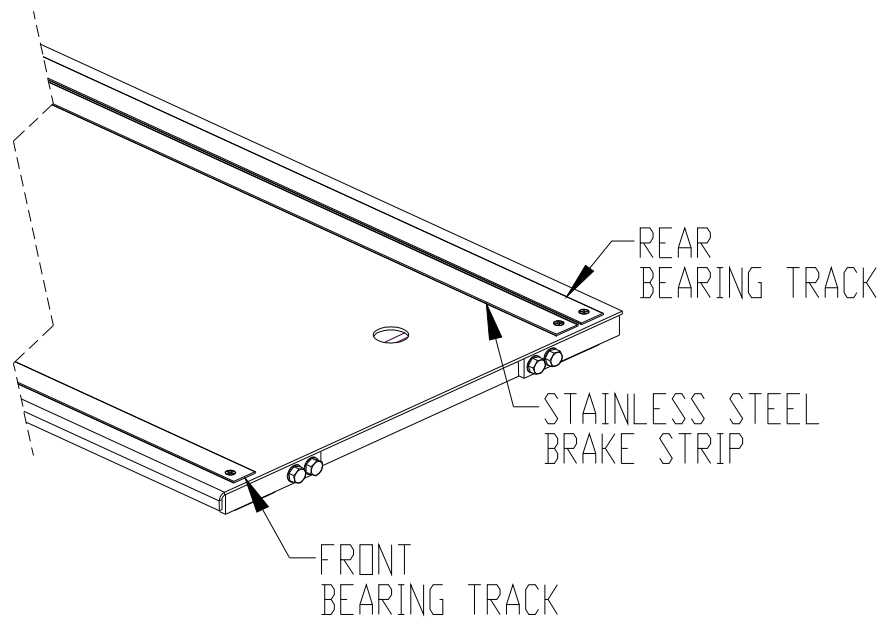

- 3.1.2 If the floor was not prepared previously, use the Floor Rail as a template and drill 3/8" Dia., 1.75" deep holes into the floor. The floor anchors supplied in the hardware kit are intended for use with concrete floors. Insert a floor anchor in each of the holes, but DO NOT tighten at this time. If the floor is made of a material other than concrete, follow the same procedure using proper fasteners for the floor material on site.

- 3.1.3 Use the shims supplied to level the Floor Rail in all directions. In most cases, the 30 shims supplied in the kit should be sufficient to level the rail. However, additional shims are available from the factory or distribution center if needed.
- 3.1.4 Please contact Summit Industries to order more shims. Shims sent with the mounting kit are shown in Figure 1, page 9-2.
- 3.1.5 Tighten the anchor bolts and install the decorative hole plugs in the rail mounting holes.



### NOTE

*The hardened steel bearing tracks on the floor rail must have a thin film of oil to resist corrosion. They are shipped oiled from the factory however if insufficient oil remains after installation reapply. **DO NOT** apply oil to the stainless steel brake strip.*

- 3.1.6 At this time, you should perform a preliminary Tubestand leveling check. Slide the Floor Car Assembly onto the Floor Rail and check for wobble.

Also, make sure the car is level.

There are three eccentric load bearings in the corners of the Floor Car. All of these bearings are factory set to a level Floor Rail and should not require adjustment if your Floor Rail is also level.

If necessary, the two rear bearings can be accessed by removing the square covers on the top of the Floor Car. The third eccentric bearing is located in the right front corner of the Floor Car and can be accessed by removing the car from the Floor Rail. If you find it necessary to adjust any of these bearings, you should use the instructions in paragraph 3.6 "Tubestand Leveling and Adjustments".

## 3.2 Column Installation

- 3.2.1. Position the Tubestand Column on the two wood blocks with the Transverse Arm Assembly pointing up. Using two people, pick up the Floor Car with the sloped side up, and slide it over the shaft at the bottom of the column. The shaft will protrude through the two bearings in the Floor Car. Insert the retaining ring in the groove in the shaft to retain the column to the car. The hardware, cable clamps, tie wraps, and other items needed to install the column, Tube platform, and cables are found in the Hardware Mounting Kit, packed with the column. (*Note - in some cases, this kit may be in a number of packages.*)



**WARNING**

**IN THE FOLLOWING STEPS, YOU WILL REMOVE THE COLUMN COUNTERWEIGHT AND VERTICAL SLIDE LOCKING BLOCKS. USE EXTREME CAUTION, AS REMOVING THE BLOCKS WILL PERMIT THE WEIGHTS TO MOVE. BE PREPARED TO HAVE THE WEIGHTS SHIFT AND UNBALANCE THE COLUMN**

- 3.2.2 Remove the counterweight locking screw from the side of the Tubestand Column. This screw is easily identified by the tag directing its removal.
- 3.2.3 Free the counterweight and vertical slide by sliding the locking blocks from inside the Tubestand Column. Make sure that the counterweight cables are properly positioned on the pulleys. Using a 2 x 4 or similar device, push the counterweight to the bottom of the column to prevent it from sliding when the tubestand is stood up vertically.



**NOTE**

*The counterweight shipping blocks and the screw may be useful if the equipment is ever relocated or when performing maintenance procedures. Therefore, we recommend that you keep them for possible future reuse.*



**WARNING**

**IN THE NEXT STEP YOU WILL LIFT AND POSITION THE ASSEMBLED TUBESTAND, COLUMN AND FLOOR CAR, ONTO THE FLOOR RAIL. THIS ASSEMBLY WEIGHS APPROXIMATELY 340 POUNDS AND WILL REQUIRE ADDITIONAL MANPOWER AND/OR A MECHANICAL LIFTING DEVICE TO SAFELY COMPLETE THIS STEP.**

- 3.2.4 Erect the assembled Tubestand Column and Floor Car next to one end of the Floor Rail, with the sloped side of the base next to the front edge of the rail. Lift the column and car and slide them onto the Floor Rail assembly. If you have difficulty engaging the bearings on the rail, loosen the front and rear bearing capture brackets with a 1/8" Allen wrench to gain more clearance. A second method is to remove the front and rear bearing capture brackets entirely to roll the tubestand onto the Floor Rail. Be careful not to roll the tubestand off the Floor Rail. When the column and car are mounted on the rail, re-tighten or replace the bearing capture

# Model FM Tubestand

brackets and move the assembly from one end to the other. If the assembly does not glide freely without wobble, adjust the front bearings in the Floor Car for smooth, wobble-free travel.

3.2.5 Install two rail stops (*part of the Rail Mounting Kit*) on the front and back end of each rail in the Floor Rail, using the hardware supplied in the kit.

3.2.6 Wire the Floor Car assembly to the junction box. This is accomplished by taking the loose cables sheathed in vacuum hose from the bottom of the junction box located on the back of the column, and joining them to the corresponding connectors in the Floor Car.

3.2.6.1 The conduit connects to the Floor Car in the location as shown:



3.2.6.2 Route the gray power cable from Junction Box through the opening towards the front as shown and connect to the power supply:



## Model FM Tubestand

- 3.2.6.3 Route the GND wire (GRN/YEL) through the opening towards the rear as shown and connect to the GND stud on the Floor Car:

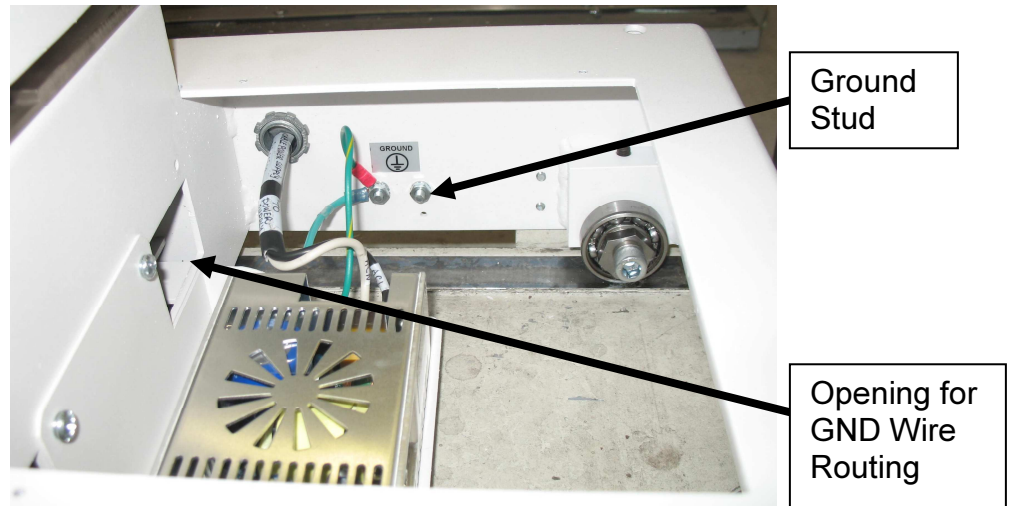

- 3.2.6.4 Route the cables for the longitudinal locks through the opening on the other side of the Floor Car and join with the corresponding connectors:

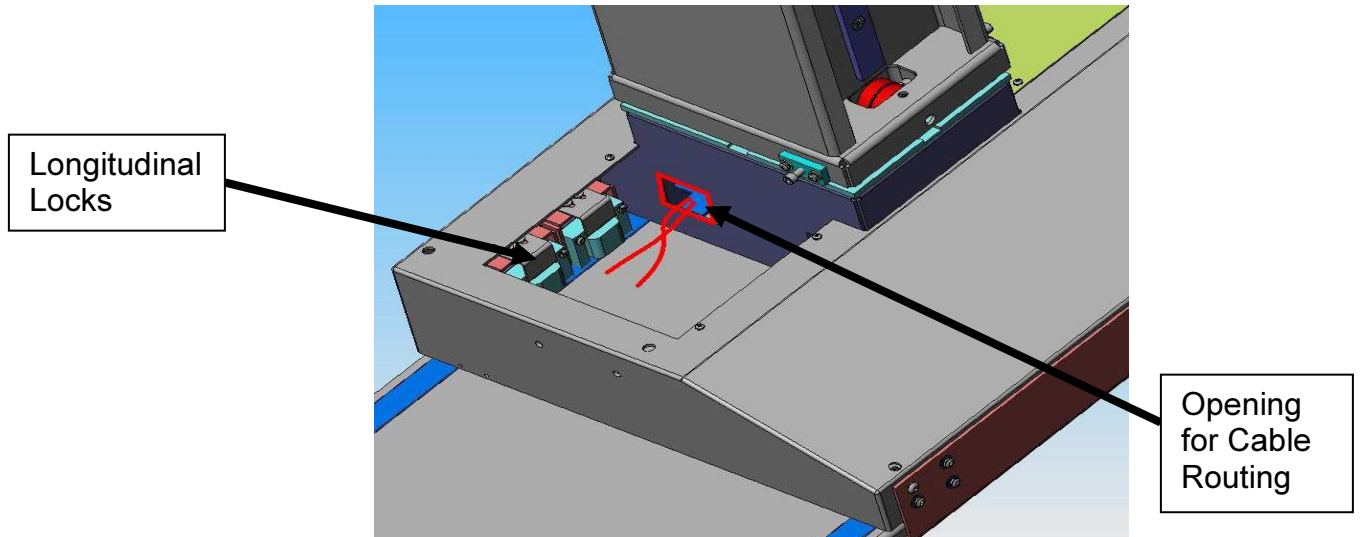

### 3.3 MOUNTING X-RAY TUBE, ANGULATION BOX, COLLIMATOR AND CONTINUOUS SID MONITOR

- 3.3.1 The tube mount assembly is mounted to the transverse arm at the factory. Note that vertical adjustment of the tube mount is available via four hex-head bolts to help balance the weight of the collimator vs. the tube when angulating towards the wallstand. That adjustment can be done when these items are mounted later in the process.

In all applications, the tube's Anode should be up when the tube is aimed at the Wall Stand. This is done for heel-effect considerations.

- 3.3.2 If equipped with Port Style tube mount:

Raise the X-ray tube and carefully place its port onto the tube mount plate. Be sure not to allow the transverse arm to “Roll” CW or CCW until the tube/collimator are fastened together.

Refer to the Collimator Installation Instructions to fasten the collimator to the tube and tube mount.



**NOTE:** Some tube types require metric thread M6 bolts, while others require English thread ¼”-20 bolts. **Damage to the tube threads resulting from improper bolt selection is not covered under warranty.** Refer to the tube manufacturer’s installation instructions on mounting bolt requirements for the tube type used at this installation.

### 3.3.3 If equipped with either 6” or 6.75” diameter Trunnion Rings:

Unscrew the Trunnion lock knob and carefully place the X-ray tube into the open Trunnion rings. Be sure not to allow the transverse arm to “Roll” CW or CCW until the tube/collimator are fastened together. Close up the Trunnion rings and tighten the lock knob. Verify that the Trunnion rings will hold the tube securely and that when the knob is loosened slightly, the tube can rotate within the Trunnion rings.

Install the angulation box mounting plate (1/8” thick) between the tube and collimator. It is of vital importance that the proper bolt type be used. This is often easier to do with the tube angulated so that the port is pointing towards the ceiling.



**NOTE:** Some tube types require metric thread M6 bolts, while others require English thread ¼”-20 bolts. **Damage to the tube threads resulting from improper bolt selection is not covered under warranty.** Refer to the tube manufacturer’s installation instructions on mounting bolt requirements for the tube type used at this installation.

### 3.3.4 Install the collimator per manufacturer’s instructions. Verify that the appropriate spacers are installed to meet tube focal spot to collimator mounting surface distance requirements, by referring to the instructions for these individual components. Note that the number of spacers required will vary, depending on the collimator and x-ray tube used.



**NOTE:** If too many spacers are used the x-ray field will be smaller than the light field. If too few spacers are used the x-ray field will be larger than the light field.

### 3.3.5 Install the angulation box to the mounting plate by the hardware provided.

3.3.6 (See *below* for visual reference.)

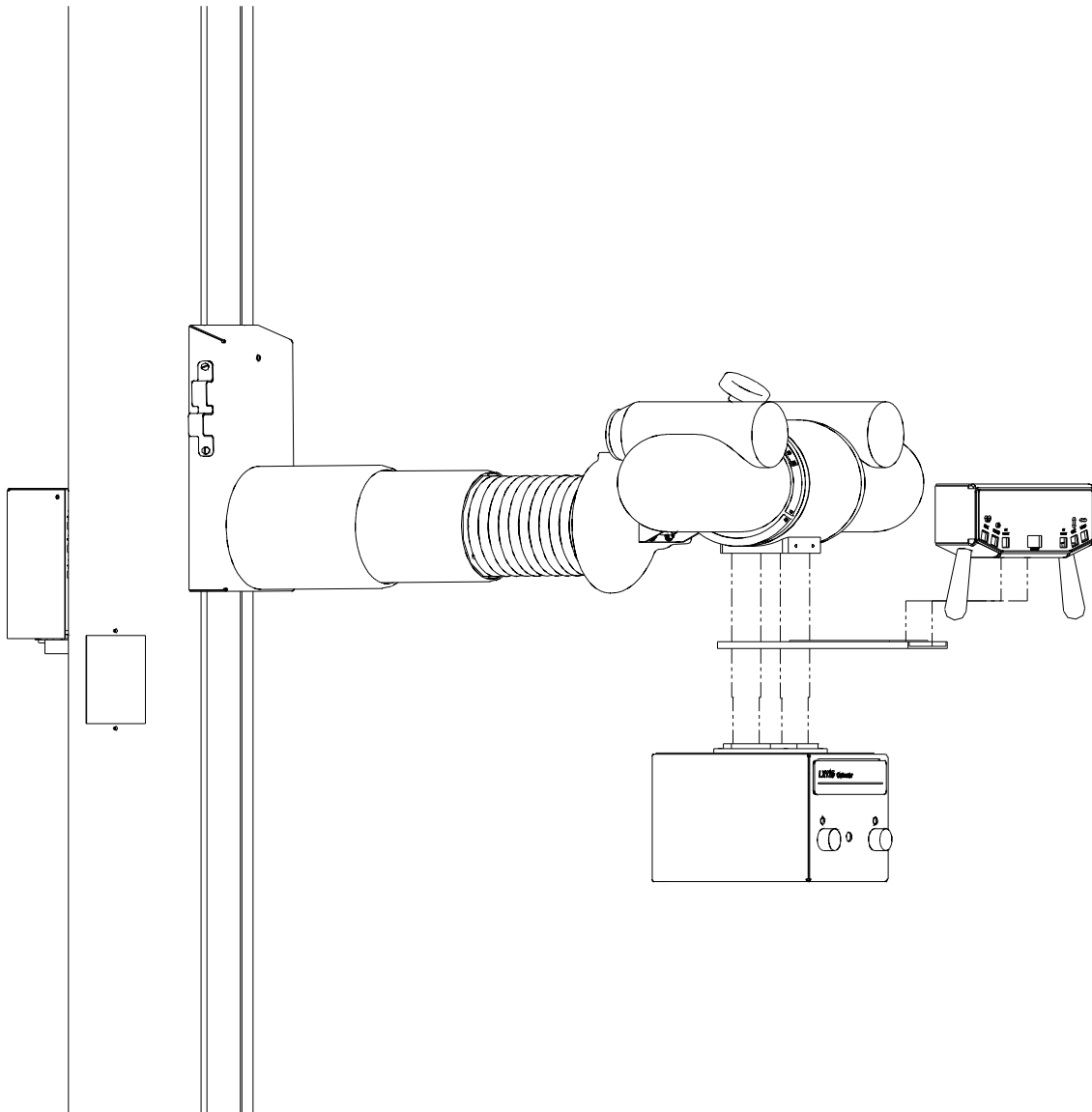

**ASSEMBLY OF TUBE, TRUNNION RINGS, COLLIMATOR,  
ANGULATION BOX**

3.3.7 (**OPTIONAL**) Install the Continuous SID Monitor per Instruction #05809 (for PBL collimators only).

### 3.4 Installing the Other System Components (Table, Wall Stand, etc.)

Once the assembly of the Tubestand is done, the other system components can be moved into place and secured to the floor. Refer to the layout drawings for this installation. You can now install these components:

### 3.5 Installing the High Voltage Cables

The high voltage cables are prepared and installed next. The cables must be attached to the Tubestand with the amounts of cable slack specified to allow the cross carriage to rotate or move up and down freely, the column to rotate, and the entire Tubestand to move up and down the rail without fouling the cables.

#### 3.5.1 Prepare the cables as follows:

3.5.1.1 Assemble the strain relief fittings as described in the documentation.

3.5.1.2 Prepare the cable connectors with the vapor proofing compound at the Tube end only, as described in the documentation supplied with the cables.

3.5.1.3 Insert the cables into the receptacles in the X-Ray Tube housing. For a good cable drape the cables must be uncoiled and laid out straight and flat on the floor.

After the cables are connected to the X-Ray Tube, attach the cables to the Tubestand by loosening the clamps (*provided in the Hardware Mounting Kit*) on the sides of the Tubestand Column and placing the cables in the curved areas. The clamps are mounted with the slot at the top. Before tightening the clamps, provide the cable slack as described in the following paragraphs:

#### 3.5.2 High Voltage Cable Connections (see Figure 3, page 9-4)

3.5.2.1 The right side cable (*when facing the tubestand*) shall be draped as follows:

From X-Ray Tube to Clamp "A"	33-5/8"
From Clamp "A" to Clamp "B"	32-11/16"
From Clamp "B" to Clamp on Table	76"

3.5.2.2 The left side cable (*when facing the tubestand*) shall be draped as follows:

From X-Ray Tube to Clamp "A"	33-5/8"
From Clamp "A" to Clamp "B"	32-11/16"
From Clamp "B" to Clamp on Table	85-7/16"



**NOTE:** For many installations the cables may go to a wall pivot and then drape to the generator / HV Transformer, not to the table.

Figure 3, page 9-4, shows an installation from the "foot" end of the table.

3.5.2.3 Position the X-Ray Tube rotor cable and the Collimator power cable in the same position as the High Voltage Cable on the appropriate side of the tubestand. Bind these two cables together with cable ties, and bring them to the back of the column. They are connected in the next section.

3.5.2.4 Route the cables to the High Voltage Transformer, keeping polarity in mind:

The X-Ray Tube **anode** cable is on the **left** (*when facing the tubestand*), and is connected to the anode receptacle on the transformer (*for shoot left applications*).

The **cathode** cable is on the **right** of the tube, and is connected to the cathode receptacle on the transformer (*for shoot left applications*).

### 3.6 Tubestand Leveling and Adjustments

3.6.1 *Tubestand Column.* The Final plumbing of the Tubestand should be done after the tube, cables and Collimator are installed. Alternately position a bubble level on the front and one side of the Tubestand and plumb it in all directions by adjusting the eccentric load bearings in the two back corners of the Floor Car. To access these bearings remove the two square covers on the car assembly.



**NOTE:** The eccentric bearing located in the front right corner of the Floor Car should not require further adjustment if you performed the preliminary adjustment in paragraph 3.1.6.

Loosen the mounting cap screws and adjust both eccentrics until the column is vertical. Move the Tubestand to the ends of the rail and verify that the column remains plumb and vertical regardless of its position on the rail. Correct any variances found in the level of the rail using shims. If these adjustments cause the car to bind or wobble when it is moved, adjust the rear adjusting screws to change the clearance between the rear bearings, the rail, and the retaining bearings. When you are done, the car should move smoothly down the rail while the column remains in a vertical position.

- 3.6.2 *Counterweight Balancing* - Move the Vertical Slide to the approximate midpoint of its vertical travel and release the slide. If it stays in position, no further action is needed. However, if the Vertical Slide moves up or down, the counterweights must be balanced by adding or subtracting weight.

The counterweight system consists of a main counterweight and several smaller, removable, trim weights inside the Tubestand Column. In most cases, balancing is accomplished by vertically stacking trim weights from the Installation Kit in both trim weight compartments on top of the main counterweight until the Vertical Slide remains in position. Refer to Figure 5, page 9-6. Add weights equally to both compartments to ensure smooth movement of the counterweight within the column. Remove the counterweight access cover at the top rear of the column to gain access to the trim weight compartments.



**NOTE: If additional weights are needed, they are available from the factory.**

### 3.7 Tubestand Cables

The Tubestand operates from 120 VAC, 2 Amperes, as described in Section 1.7. The Tubestand power supply, mounted in the base of the Tubestand, provides 24 VDC.

- 3.7.1 Connect the Collimator power cable wires.

- 3.7.2 Replace any covers removed during the electrical connections. When mounting the top cap on the Tubestand Column, make sure that the flexible hose protecting the Vertical Lock Cable is inserted in the slot in the rear panel of the top cap. The slot is designed to support the upper end of the ribbed hose.

## **4 Configuration**

### **4.1 Electrical Configuration**

Ratings: 120 V, 50/60 Hz, 2 A

Power requirements for the Tubestand are 120 VAC, (60 Hz or 50 Hz), 2 Amperes, supplied through facility wiring described in previous sections. The 120 VAC is converted to 24 VDC for powering the electromagnetic locks by a power supply mounted in the Floor Car of the Tubestand.

### **4.2 Mechanical Configuration (See also, Figure 2)**

Ceiling height	92-1/2"
Vertical travel: floor to focal spot	14-9/16" Min; 72-7/16" Max
Longitudinal travel	96"
Floor Rail footprint	120" long; 18" wide
Front Edge of Floor Rail to Table Centerline	21-1/4"
Tubestand weight	362 lbs (Net); 449 lbs (Gross)
Platform Assembly weight	120 lbs (Net); 130 lbs (Gross)
Extension from column centerline to focal spot	28" Min; 38" Max
Column rotation	±180 where installation conditions permit
Tube rotation	90° detents for lateral Decubitus projections (electrical automatic stops ±90 rotation and horizontal stops)
Front Edge of Floor Rail to rear wall	23-1/2"

## 5 Calibration

The FM Tubestand is designed and built to satisfy exacting medical standards. However, because of the wide range of mobility afforded the X-Ray Tube, even small inaccuracies in the leveling or plumbing of the Tubestand can affect the accuracy of entire X-Ray system. Calibrating the Tubestand necessarily includes calibration of the entire system. Therefore, the following calibration procedures involve not only the alignment of the tubestand, but also the alignment of the table and Wall Stand to the Tubestand to ensure total system accuracy.

### 5.1. Small Room System Calibration

- 5.1.1. Installations in small rooms (smaller than that specified) may require special calibrations. Refer to your Technical Support Service Representative for these procedures.

### 5.2. Transverse Arm Adjustment

#### 5.2.1. Accessing Transverse Arm Adjustment

- 5.2.1.1. The accordion/bellows assembly is connected to the transverse arm by four Phillips head screws, one each at about 10 o'clock and 2 o'clock of the bellows, and two at about 6 o'clock. Remove these four screws and retract the bellows towards the trunnion assembly.
- 5.2.1.2. Remove the two small Phillips screws that secure the transverse arm's inner sleeve, and pull the sleeve out towards the trunnion assembly.
- 5.2.1.3. The four Allen screws used to adjust the angle of the arm are now visible, as well as the four hex head "locking" bolts used to secure the adjusted angle position of the arm. See **Figures** below for reference.

#### 5.2.2. Adjusting The Transverse Arm

- 5.2.2.1. To raise the arm for vertical tracking (bring centerline forward)
  - 5.2.2.1.1. Loosen the four locking hex bolts
  - 5.2.2.1.2. Tighten the two bottom Allen adjustment screws
  - 5.2.2.1.3. Retighten the four locking hex bolts
- 5.2.2.2. To lower the arm for vertical tracking (move centerline rearward)
  - 5.2.2.2.1. Loosen the four locking hex bolts
  - 5.2.2.2.2. Tighten the two top Allen adjustment screws
  - 5.2.2.2.3. Retighten the four locking hex bolts
- 5.2.2.3. To move the arm and centerline "outward" for horizontal tracking
  - 5.2.2.3.1. Loosen the four locking hex bolts

- 5.2.2.3.2. Tighten the two Allen adjustment screws closest to the wallstand
- 5.2.2.3.3. Retighten the four locking hex bolts
- 5.2.2.4. To move the arm and centerline “inward” for horizontal tracking
  - 5.2.2.4.1. Loosen the four locking hex bolts
  - 5.2.2.4.2. Tighten the two Allen adjustment screws furthest from the wallstand
  - 5.2.2.4.3. Retighten the four locking hex bolts.

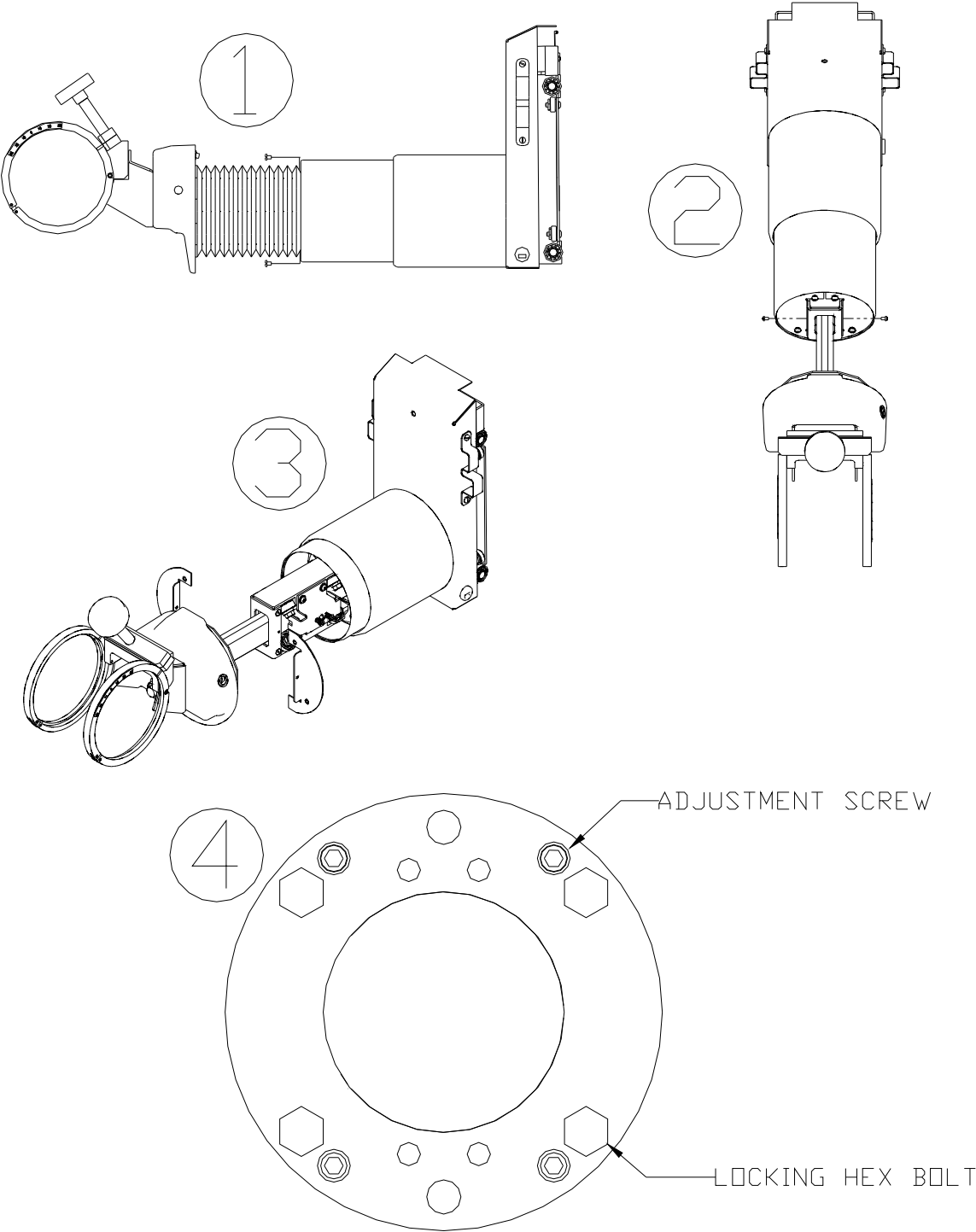

**TRANSVERSE ARM ADJUSTMENT AND ACCESS**

**5.3. Calibrating the Collimator Light Source to the X-Ray Field**

5.3.1. Calibrating the system begins with adjusting the Collimator light source so that it coincides with the X-Ray field generated by the tube. Once these two fields are coincidental, the light field is used to align the balance of the system components with the tubestand. This ensures accuracy at all

vertical and horizontal SIDs. The accuracy of all adjustments should be held to within 1.5% of SID.

5.3.2. Before beginning the procedure, verify that the following conditions exist:

5.3.2.1. The tubestand, generator, and table base (*with the High Tension Transformer inside*) are anchored to the floor. The Tubestand and generator are securely anchored, but the table base is still free to move slightly.

5.3.2.2. The Wall Stand and the table top are not in place.

5.3.2.3. Power is available to these components, and the generator is capable of generating X-Rays (*the generator should be calibrated before hand*)



### NOTE

*In the following steps, once the film cassette is exposed, all system components must remain in the same place until the procedure is done. Take care to ensure that everything is locked in place before exposing the film. If any movement occurs afterwards, the entire procedure must be started over again from the beginning.*

5.3.3. Calibration Steps:

5.3.3.1. Apply power to the system and position the X-Ray Tube over the Bucky in the table base. Adjust the Tubestand to the 40" SID above the film plane of the cassette and ensure that the locks keep the Transverse Arm and X-Ray Tube from moving.

5.3.3.2. Place a film cassette in the film tray, and center the film as accurately as possible in the center of the tray. Place tape strips at the corners of the film cassette so that it can be removed to develop the film and replaced in exactly the same position after the film is developed. Insert the tray fully. Position the Table Bucky beneath the X-Ray Tube.

5.3.3.3. These components should be locked in place by the table's electromagnetic locks. Using small lengths of solder, make a cross on the center of the film cassette, and securely tape the cross in place.

5.3.3.4. Turn on the Collimator light by pressing the button on the front panel, and center the Collimator light field on the film cassette. Adjust the Collimator shutter controls so that the light field is approximately 2-5/16" smaller in both dimensions than the film cassette. Tape three washers in the light field so that their edges define the edge of the light field in three of the four light field quadrants.

5.3.3.5. Expose the film, adjusting the technique for a film density of 1.

- 5.3.3.6. Remove the film cassette by turning the locking mechanism in the tray. *Do not remove the tray from the Bucky.*
- 5.3.3.7. Develop the film.
- 5.3.3.8. Replace the film cassette in the tray, being careful to put the cassette back exactly between the tape strips. Place the exposed film over the cassette, aligning the images of the washers over the washers on the cassette. When the two coincide, tape the film in place.
- 5.3.3.9. Turn on the Collimator light and adjust the light field to match the X-Ray field defined on the film as described in the following steps.
- 5.3.3.10. To adjust the light field front to back. Refer to the manual provided with the Collimator type used with the system.
- 5.3.3.11. To adjust the head to foot (left to right) position, remove the rear cover of the Collimator, loosen the lamp bracket screws, and adjust the lamp bracket left or right to align the light field to the X-Ray field.
- 5.3.3.12. Align the Collimator crosshairs to the solder crosshairs taped to the film cassette. Refer to the Collimator manual for how to adjust the cross hair window.
- 5.3.3.13. When the light field matches the X-Ray field, the alignment of the two fields is complete.

### 5.4. Final System Alignment

- 5.4.1. With the X-Ray field and the Collimator light field aligned to each other, the Collimator light is used for the final alignment of the system components. Projecting the light onto the adjacent walls and floor allow precise adjustments to be made to the Tubestand Column to ensure accuracy and to accurately locate the other components in the system.

### 5.5. Final Column Adjustments

- 5.5.1. The vertical plumb of the column was adjusted in Section 3 with a bubble level. This is adequate for the adjustment of the fields in the preceding section. Final adjustments in the following procedure ensures the best possible system accuracy.
- 5.5.2. Move the Tubestand to the end of the rail adjacent to where the Wall Stand will be installed. With the Transverse Arm at the detent position, rotate the arm and project the Collimator light onto the wall. Raise the arm to the highest level and mark the location where the Collimator crosshairs are projected on the wall.

- 5.5.3. Suspend a plumb bob on a string through this spot.
- 5.5.4. Project the crosshairs again on the top of the plumb bob line. Then move the projected crosshairs down along the string to determine if the arm is moving down in a perfectly vertical plane. If the crosshairs move to one side or the other of the string as the arm drops, the Tubestand Column is not completely vertical.
- 5.5.5. Adjust the vertical position of the column, using the procedure of adjusting the eccentrics in the rear bearings, described in Section 3.6, until the crosshairs track the string from top to bottom. Leave the plumb bob and string in position, as it will be used later to align the Wall Stand.
- 5.5.6. Rotate the arm until the Tube points to the floor. Move the arm to the top of the travel, turn the Collimator light on and project the crosshairs on the floor. Mark this location as your starting point.
- 5.5.7. With the Collimator light on, slowly drop the arm towards the floor, and note any movement of the crosshairs in relation to the starting point.
- 5.5.8. If the crosshairs move toward or away from the column, confirm the Column verticality and Trunnion adjustment.
- 5.5.9. If the crosshairs move toward the left or right as the arm drops, loosen the Roll Center Switch and detent, initially adjusted in Section 5.2, Transverse Arm Adjustment, and rotate one side up or down until the movement is eliminated. Tighten the switch and detent and check the tracking again.
- 5.5.10. Move the Tubestand towards the wall as in step 5.5.2. Place the arm midway in its travel above the floor, project the crosshairs on the wall, and note their location. Then move the Tubestand at least 72" away from the wall. With the light on, move the Tubestand towards the wall and note any movement of the crosshairs away from that point. If the crosshairs move away from the initial location, loosen the four bolts retaining the top plate on the Floor Car. These bolts are shown in Figure 4, page 9-5. Twist the column and plate in relation to the car, and repeat the measurements. When any movement of the crosshairs has been eliminated, tighten the four bolts.

### 5.6. Aligning the System Components

- 5.6.1. Once the Tubestand is aligned, the table and Wall Stand can be anchored in position, using the following procedures:
- 5.6.2. Center the table Bucky in its range of travel, and place a film cassette in the table's film tray. Carefully center the cassette in the tray.
- 5.6.3. Move the Tube over the table, with the Transverse Arm centered in its travel (BUCKY CENTER light on), and turn on the Collimator light field.
- 5.6.4. Carefully move the table base until the crosshairs projected by the light are in the center of the film cassette.
- 5.6.5. Without moving either the Tubestand or the table base, slide the table top on to the base. Refer to the Table Service Manual for the procedure to mount the top. Move the top over the base until the table top is centered front to rear.
- 5.6.6. Keeping the table top centered, and the Transverse arm in the BUCKY CENTER position, project the Collimator light onto the table top and adjust the position of the table base until the crosshairs line up on the centerline molded into the table top. Move the light to the left and right extremes of the table top to ensure that the crosshairs stay on the centerline from one end of the top to the other.
- 5.6.7. Anchor the table base to the floor.
- 5.6.8. The plumb bob and string used in the Tubestand alignment can now be used to align the mounting of the Wall Stand. There are many Wall Stands which can be used with the system. The relationship between Film center and Column center will differ between models. Refer to the Wall Stand Service Manual for mounting dimensions. When the Wall Stand column is aligned to the plumb bob, tighten the top anchors just enough to keep the Wall Stand column in position, and then remove the plumb bob and string.
- 5.6.9. Move the film cabinet on the Wall Stand to the top of its travel.
- 5.6.10. Move the Tubestand to 72" from the Wall Stand, ensure that the Tubestand BUCKY CENTER light is on, rotate the tube, and project the Collimator light onto the Wall Stand cabinet. Adjust the position of the top of the Wall Stand until the crosshairs in the Collimator light fall on the center of the film cabinet face.
- 5.6.11. Lower both the film cabinet and the Tubestand to the bottom of the film cabinet travel and adjust the position of the bottom of the Wall Stand until the crosshairs again match the center of the film cabinet face.



### NOTE

*It is very important that you make sure that the Wall Stand is firmly secured to the wall and floor as described in the next two steps. If not securely mounted, the Wall Stand will move slightly when the Bucky operates at Super Speed, blurring the image on the film.*

- 5.6.12. Repeat the previous two steps (steps 5.6.10 and 5.6.11) until the Wall Stand is aligned. Tighten the top mounting anchors in the Wall Stand.
- 5.6.13. If the floor is not completely level, you may have to insert shims between the bottom of the Wall Stand and the floor to maintain the alignment. Anchor the bottom of the Wall Stand to the floor. Alignment of the system components is now complete.

**5.7 SID Labeling (standard kit 07845)**

If your FMT system has horizontal SID switches, install the actuators first (see instructions in section 5.8).

**5.7.1 Horizontal**

5.7.1.1 Fasten the pointer bracket to the right side of the floor car using two #4-40x3/8 screws.

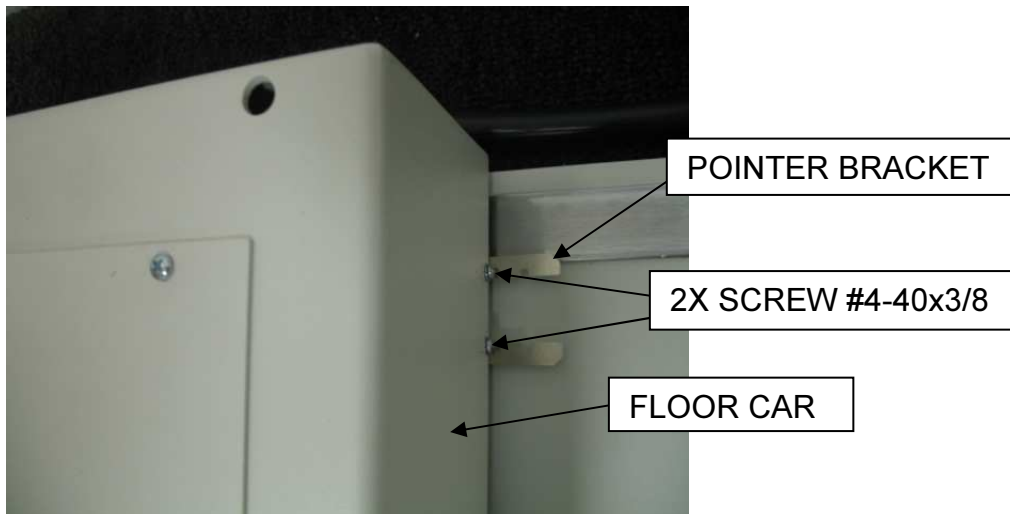

5.7.1.2 Measure the distance from the vertical Bucky stand film plane to the 40" and 72" SID Points and mark these positions between the center notches of the pointer bracket.

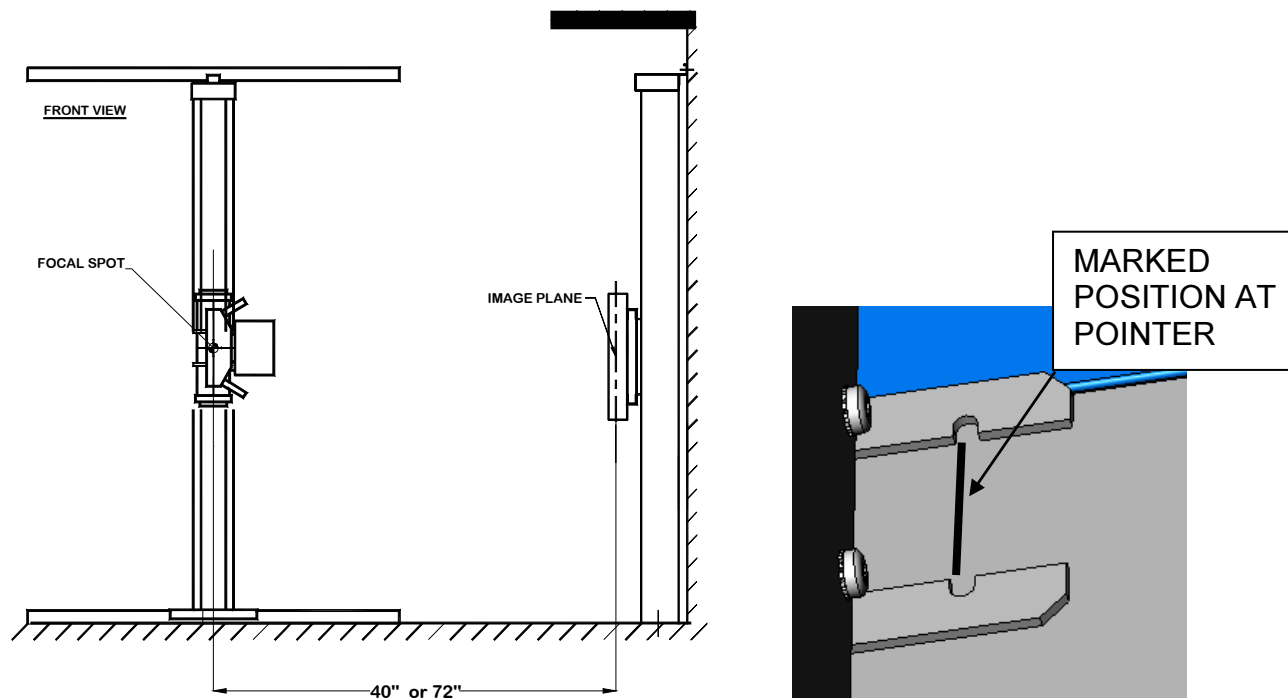

5.7.1.3 Apply the labels (40" and 72") to the floor track at the appropriate places inside the pointer bracket where the switches are actuated.

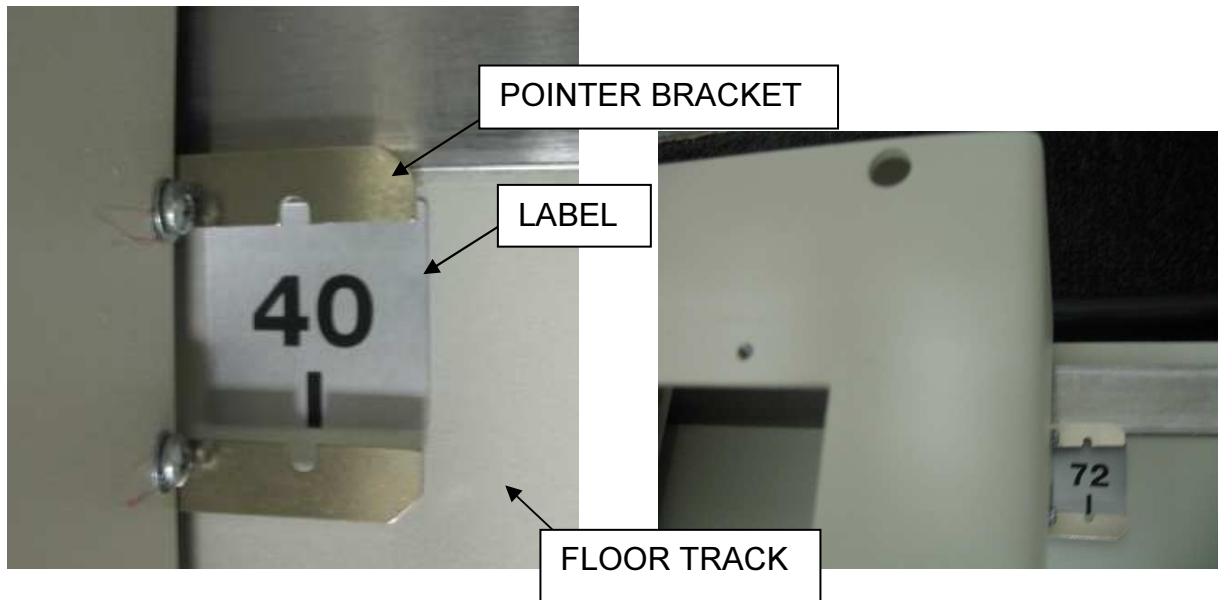

**5.7.2 Vertical**

Move the vertical carriage to achieve 40" from the table top plane to the focal spot (see Figure A). Install the vertical SID label titled "TABLE TOP" aligned with the pointer. Move the vertical carriage to achieve 40" distance from the horizontal bucky film plane to the focal spot (see figure B). Install the vertical SID label titled "IMAGE (GRID)" aligned with the pointer.

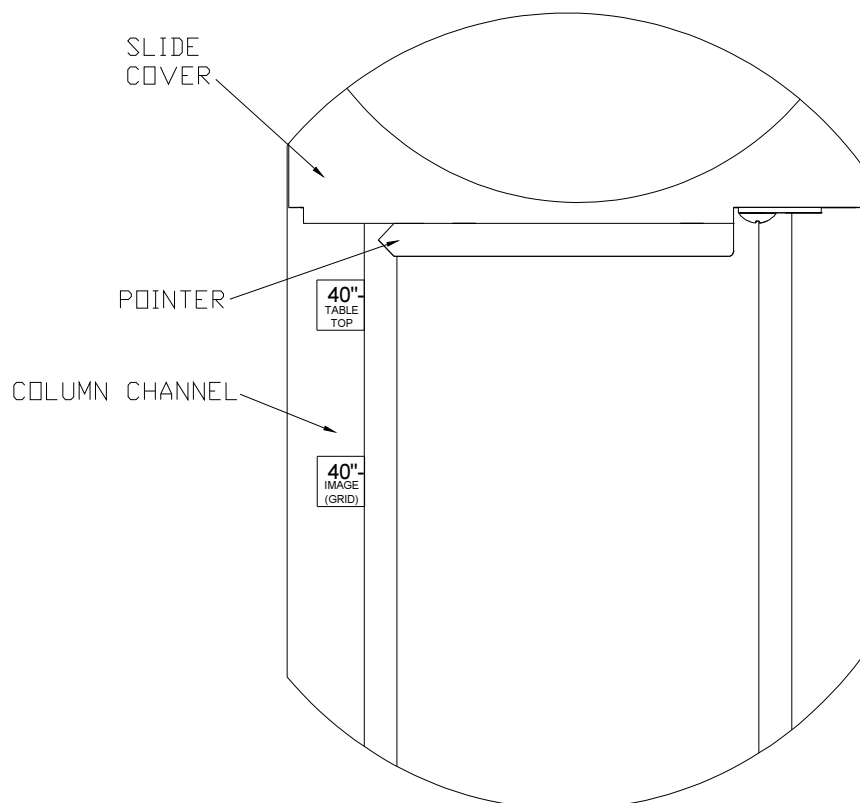

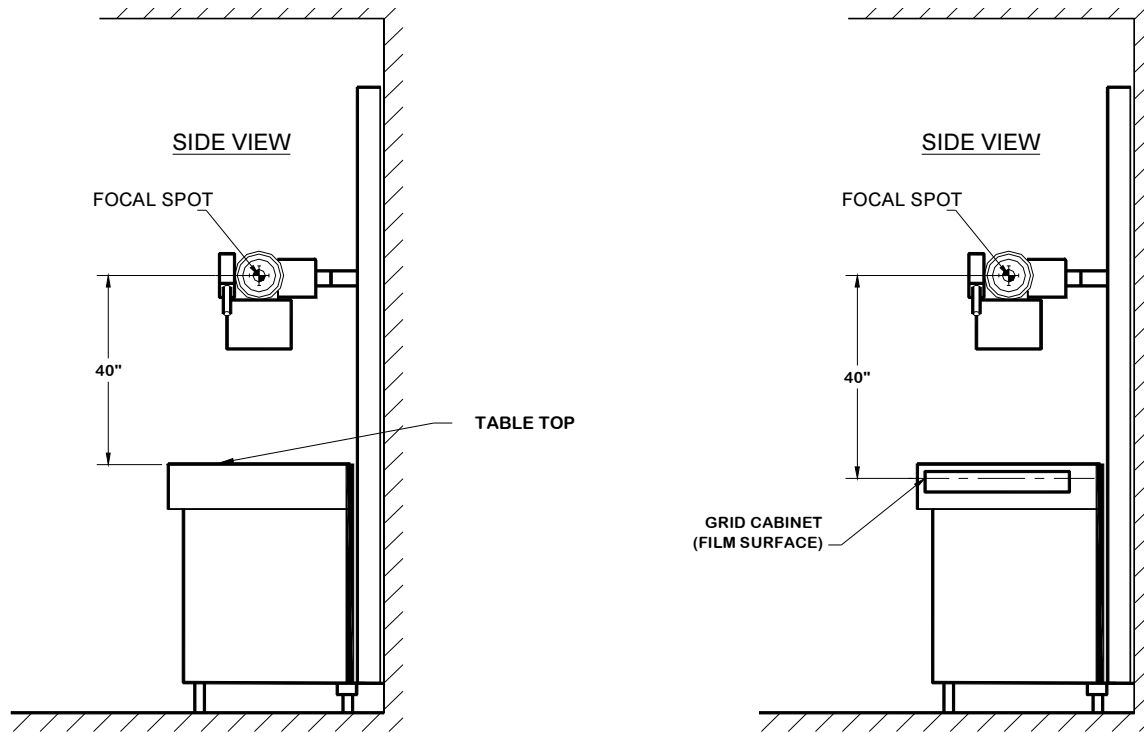

Figure A

Figure B

### 5.8 Horizontal SID Switch Installation (optional kit 07846)

The horizontal SID switch assembly and cables may come factory installed. If this is the case skip to 5.7.3 to configure the SID set points.

#### 5.8.1 Mounting

5.8.1.1 Find the horizontal SID switch assembly:

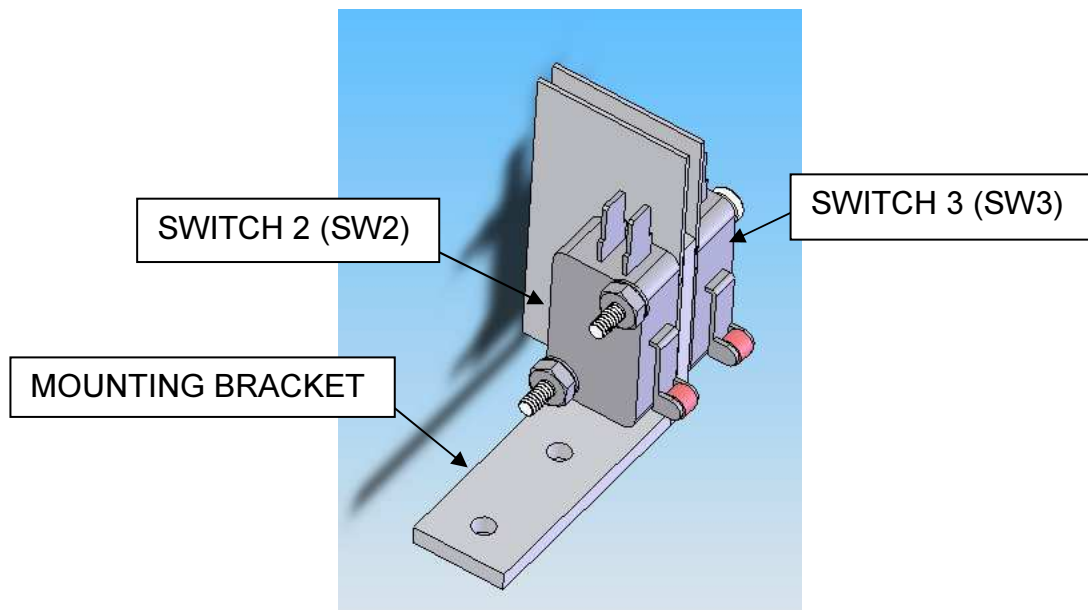

5.8.1.2 Remove the right hand top cover of the floor car.

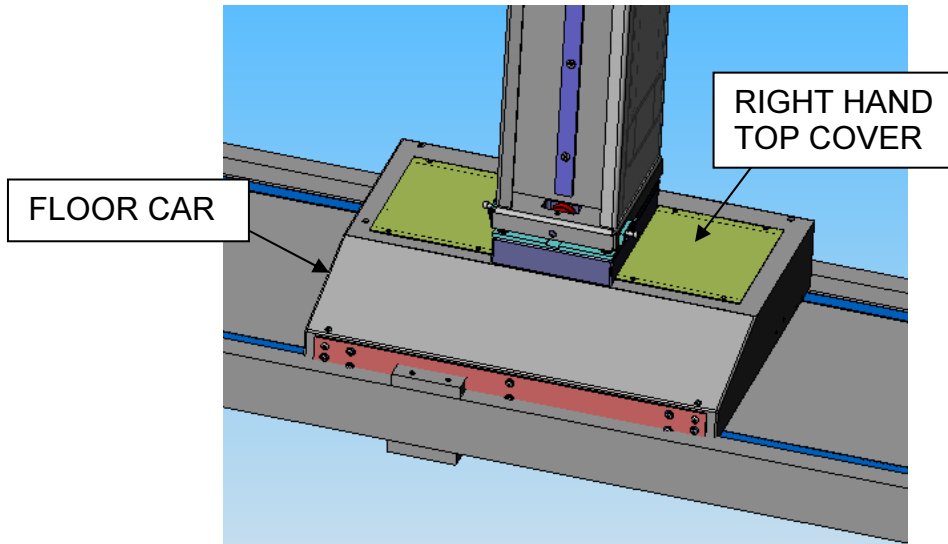

5.8.1.3 Mount the switch assembly to the inside of the floor car with the roller actuators facing the top of the floor track. Fasten with 2X #10-32x1/2" screws.

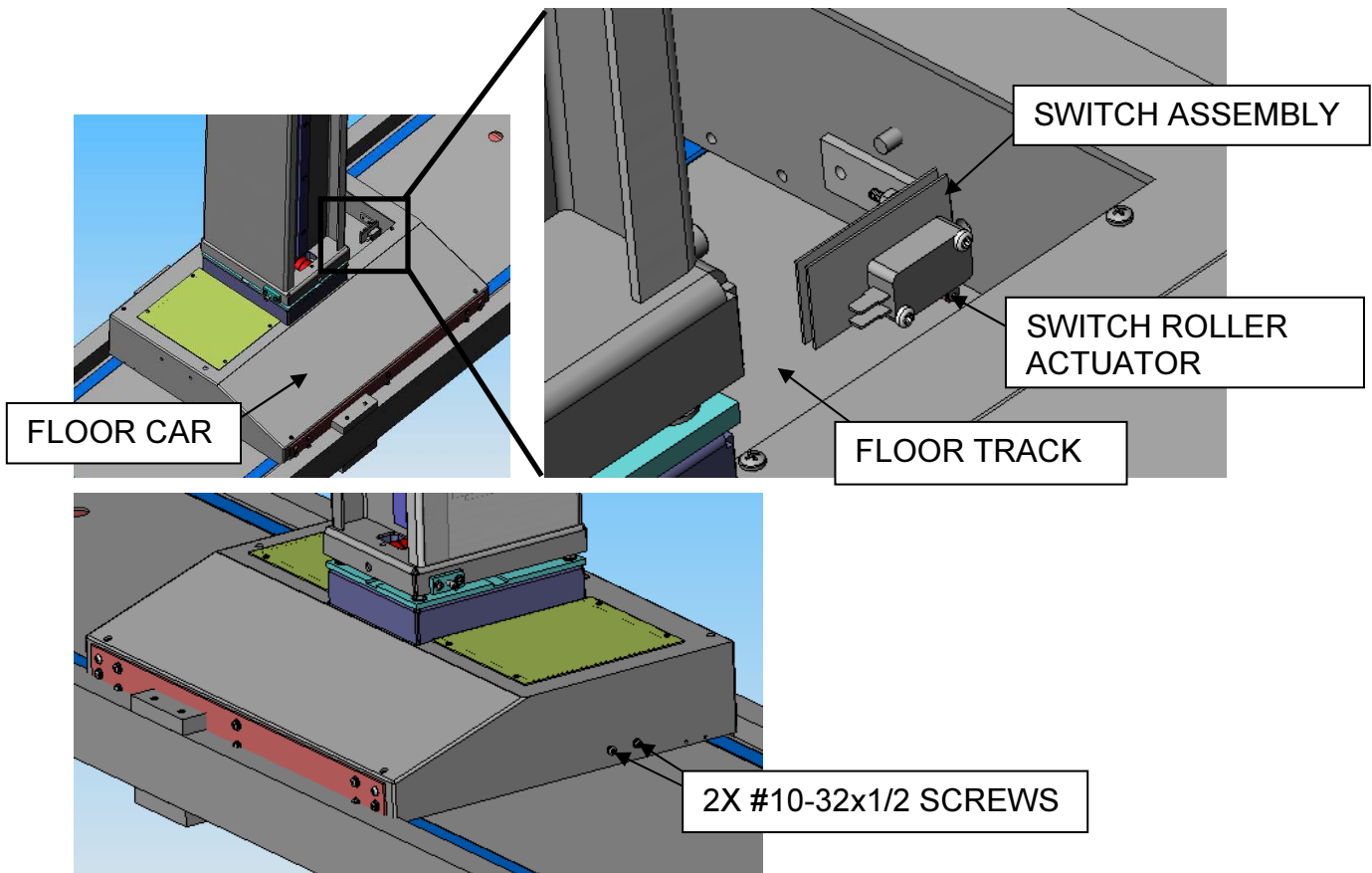

**5.8.2 Connections**

5.8.2.1 Switch Definitions

The switch on the front side of the assembly is SW3 (for 40" horizontal SID) and the switch on the rear side is SW2 (for 72" horizontal SID).

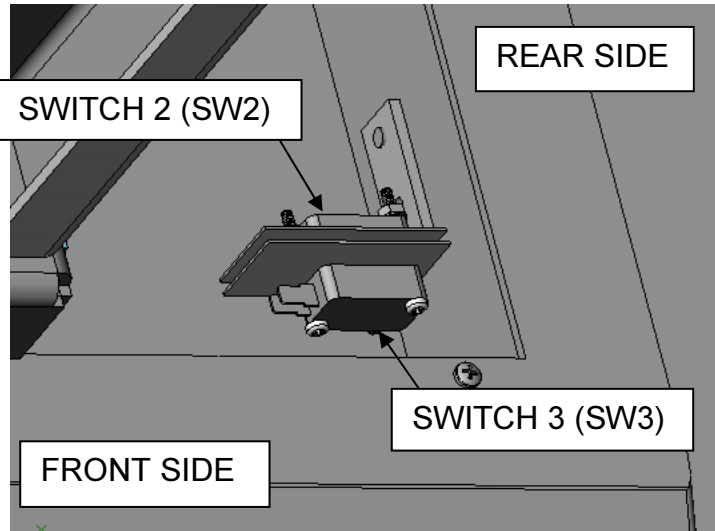

5.8.2.2 Connect cable 05411 to SW2. Add cable 02189. Connect cable 05410 to SW3. Add cable 02188. See schematic below.

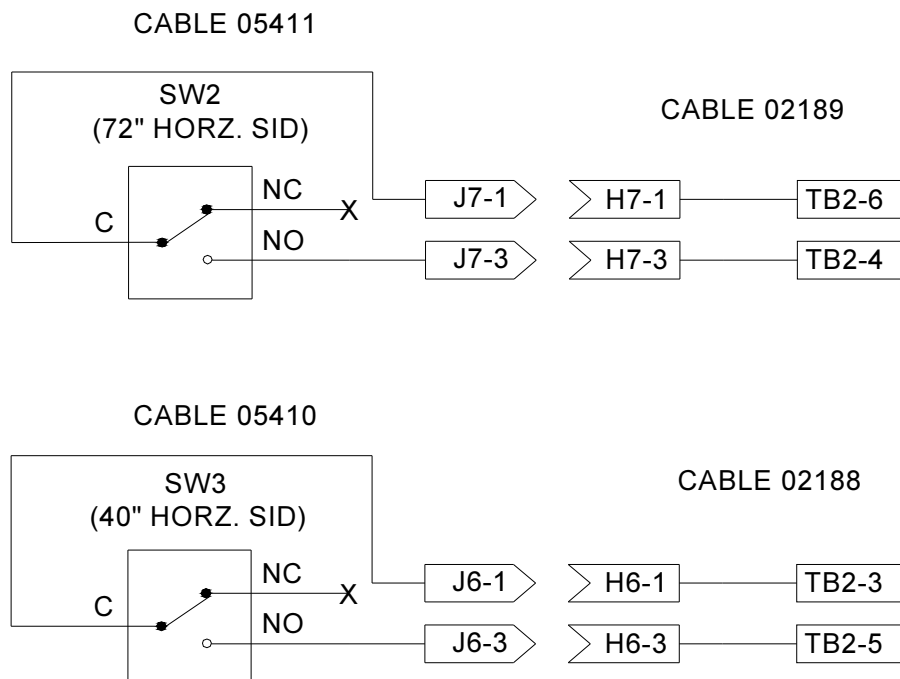

5.8.2.3 Route and connect the Horizontal SID cables to the junction box.

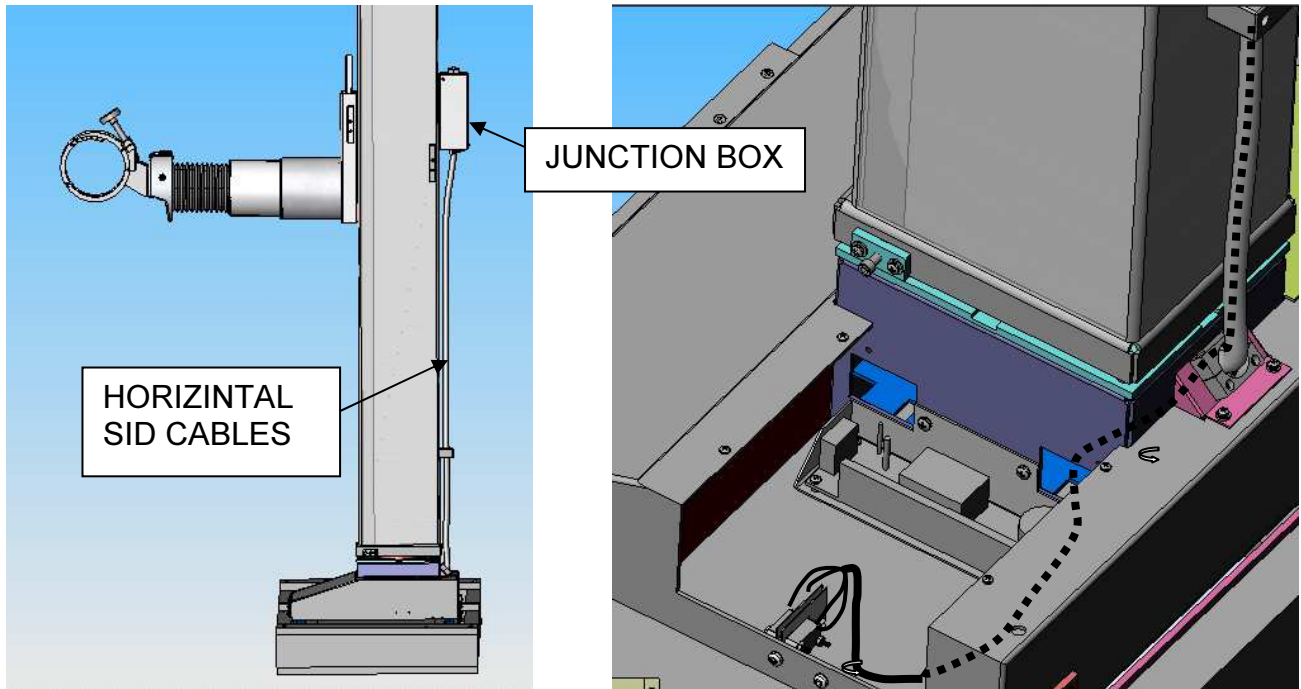

JUNCTION BOX

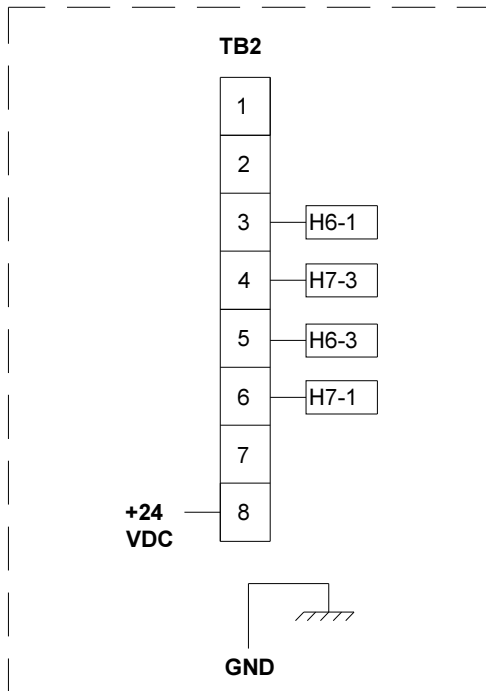

5.8.3 Horizontal SID Set Points

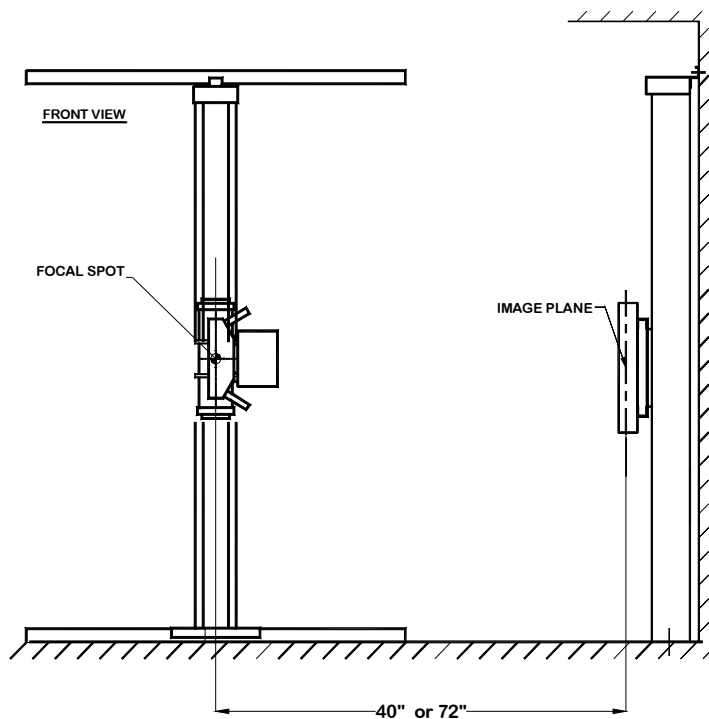

5.8.3.1 Mark the Locations

Measure to set the x-ray focal spot to image plane at 40" (SID). Mark the floor track under the switch roller of SW3. This will provide a location to place actuator. Measure to set the SID at 72". Mark the floor track under the switch roller of SW2.

5.8.3.2 Apply the Actuators

There are two methods of applying actuators to the floor track.

(a) Ramps

Stick-on aluminum ramp actuators are provided with the kit. Remove the release film on the back of the actuator and apply in each marked location on the floor track (aligned with appropriate switch).

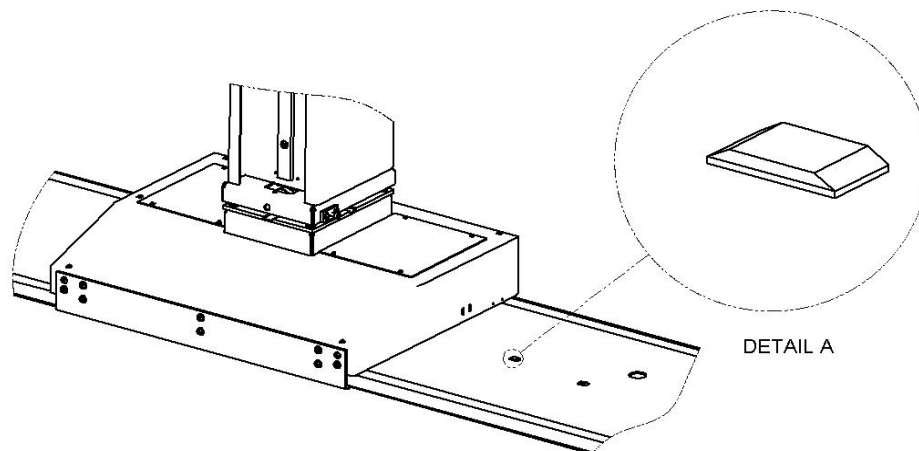

### (b) Screws

Truss head #10-32x3/8" screws are provided with the kit. If using this method, drill and tap a #10-32 hole and install a screw in each marked location on the floor track. Adjust the height of the screw head and/or adjust the switch assembly position in order to ensure proper switching at the 40" and 72" locations.

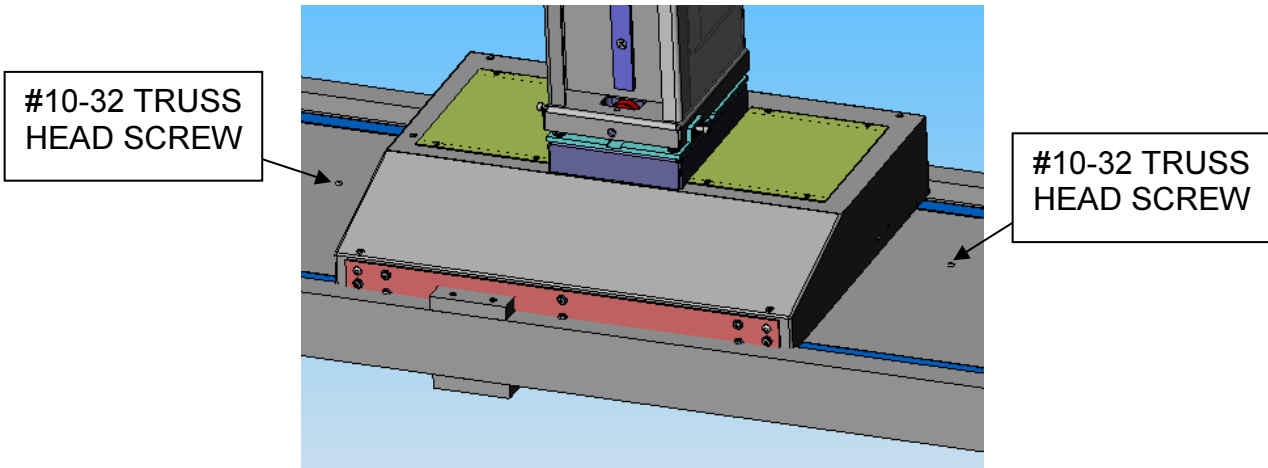

### 5.8.3.3 Verify Functionality

Verify that the switches are actuated at both the 40" and 72" SID locations. This is done in the junction box with a continuity tester (multi-meter) at TB2. Check SW3 (40") between TB2-3 and TB2-5. check SW2 (72") between TB2-4 and TB2-6.

**5.9 Vertical SID Switch Installation (optional kit 07847)**

5.9.1 Mount the vertical SID switch assembly to the top of the tubestand by two screws #10-32x3/8. The switch faces outward and downward as shown.

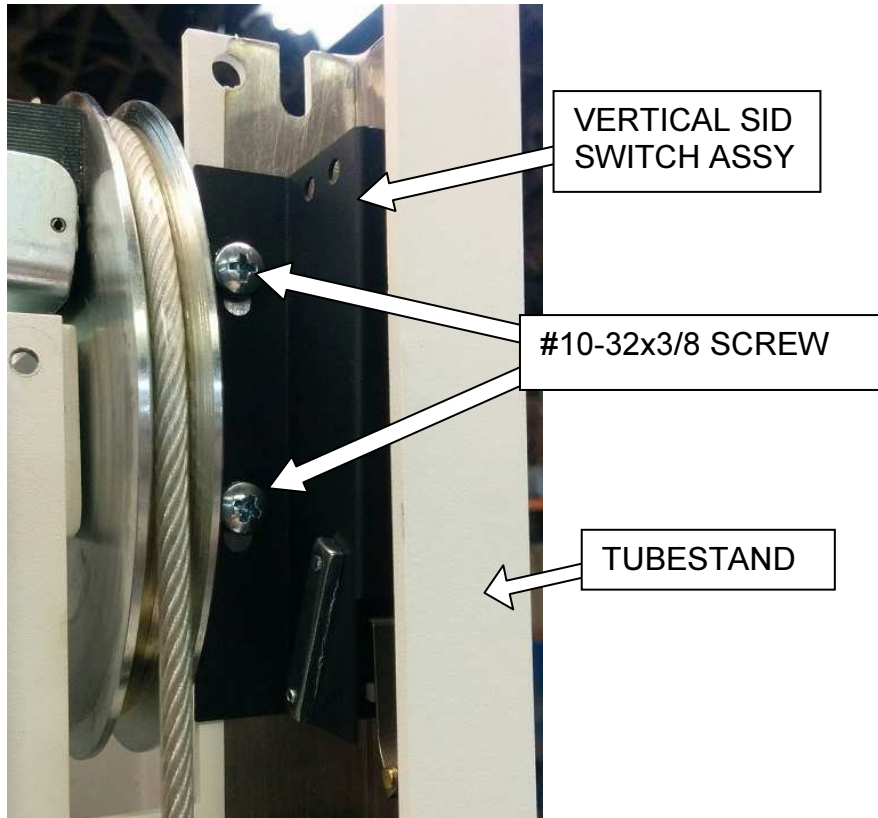

5.9.2 Mount the actuator brackets together as shown using two #8-32x5/16 screws. Note depending on where 40" SID is the position of the actuator holder can be adjusted up or down from where shown.

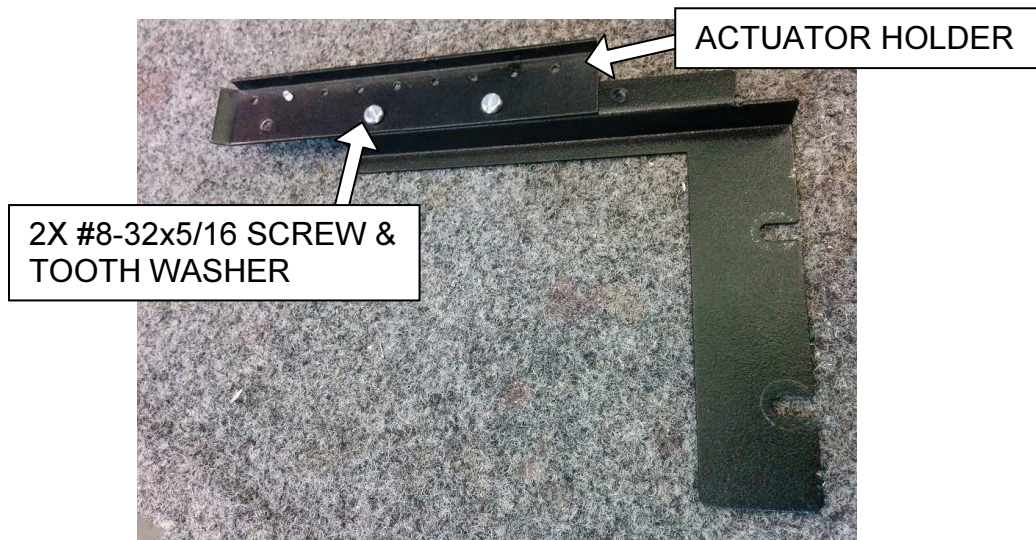

5.9.3 Adjust the tube arm to 40" vertical SID. Before mounting the actuator bracket assembly to the slide put it in position to determine and mark which hole on the

## Model FM Tubestand

actuator holder bracket is closest to the switch roller. Remove the assembly and install the #4-40x3/16 truss head screw in the marked hole. Mount the actuator assembly to the vertical slide using two #10-32x1/2 hex head screws, tooth washers, and flat washers.

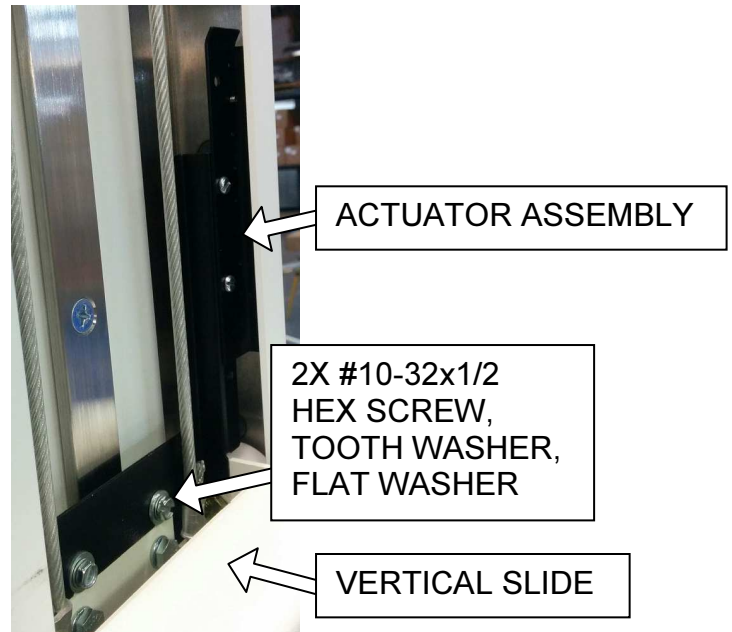

5.9.4 Connect the cable 02190 to the switch (SW1). Add cable 02187.

CABLE 02190

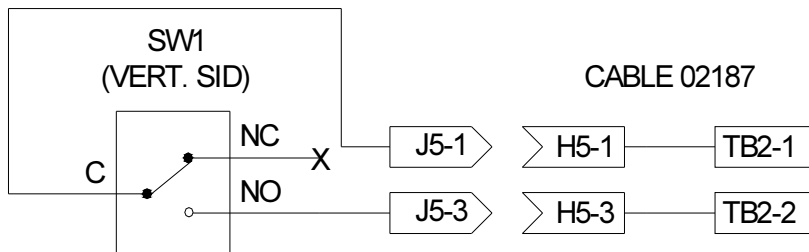

5.9.5 Route and connect the vertical SID cables to the junction box.

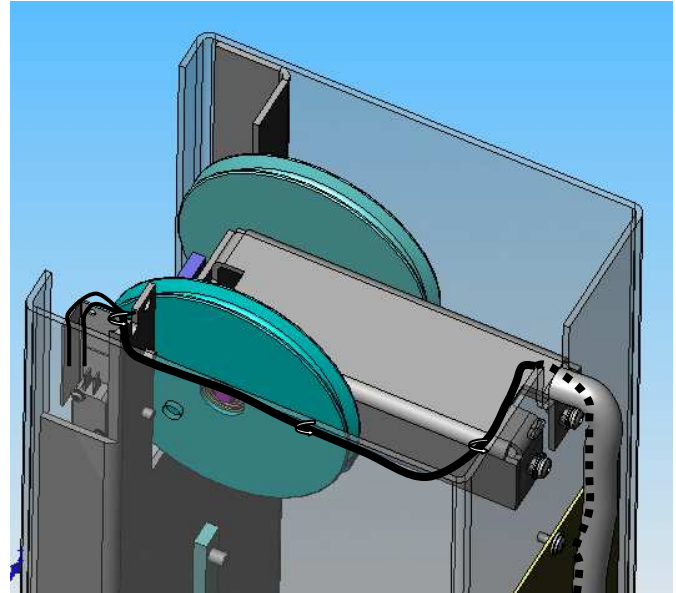
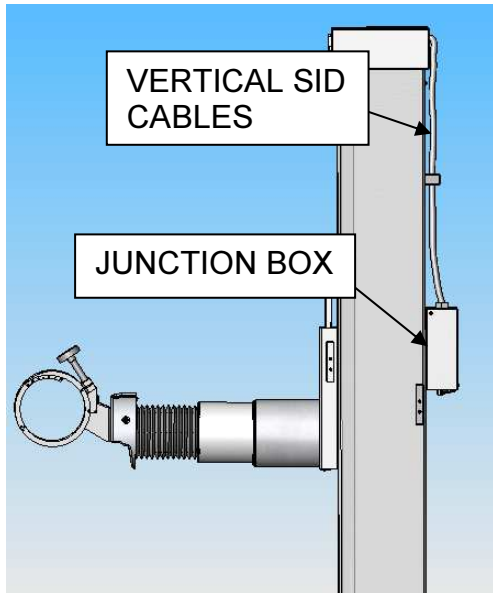

JUNCTION BOX

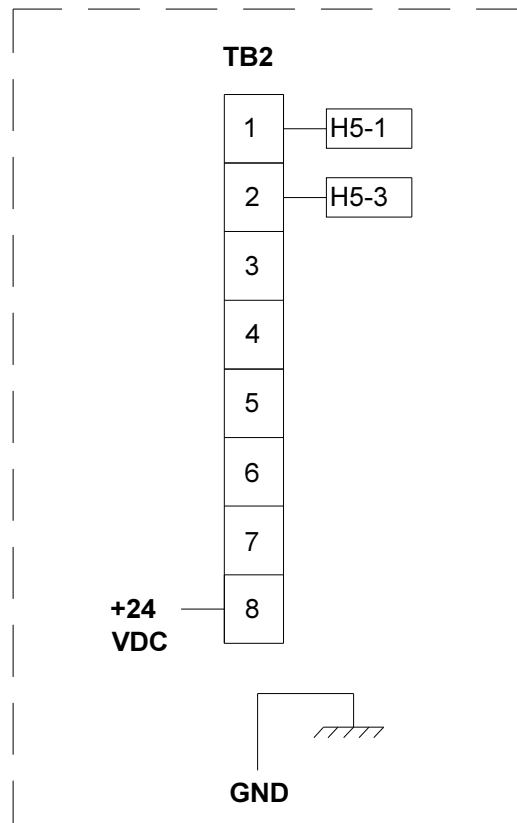

5.9.6 Verify functionality of the switch. Check continuity between TB2-1 and TB2-2 in the junction box on and off the vertical SID.

## 6 Recommended Maintenance

This section provides general information on the daily and scheduled maintenance of the tubestand.

Cleanliness is a fundamental rule in maintaining equipment. Painted metal surfaces should be cleaned using a clean cloth, mild soap, and water. **DO NOT USE** cleaners or solvents of as they may dull the finish. Polish with pure liquid or paste wax if desired. **DO NOT USE** a wax containing cleaning substance.

Cleaning the stainless steel brake strip on a regular basis is encouraged (see graphic p.3-1). If cleaning of the front and rear steel bearing tracks is required outside of scheduled routine maintenance, be prepared to re-oil them if the protective oil coating is removed.

### 6.1 Daily Maintenance

Visually inspect the system for any damage or unusual behavior. If you do see a change in performance or behavior call for service outside of scheduled maintenance to ensure proper and safe operation of the system.

Clean up any spills or extraneous material that may have been dropped on the system.

Check the electromagnetic locks to ensure that they are working properly.

### 6.2 Scheduled Routine Maintenance

The following scheduled maintenance is required for safety of operation, continued ease of use, and continued long life of the product.

The maintenance program should be performed only by qualified and authorized service personnel. Frequency of the service should be 30 days after installation and annually thereafter unless indicated otherwise by local codes and regulations.

#### 6.2.1 Tubestand

Check alignment (x-ray beam to film or receptor).

Inspect counterweight cables (including compression sleeves and eyelets) for fraying, damage, or wear. Check pulleys and pulley mounts that they are secure and undamaged. Check cable attach points that they are secure.



#### **WARNING**

**Inspection and maintenance of the entire counterweight cable system is critical for safe operation.**

Inspect all tubestand movements for binding or interference, check all bearings for proper operation.

Clean all three floor tracks to remove any foreign substances, dirt, and debris. Apply a layer of light machine oil to the front and rear tracks (see graphic p.3-1) to prevent corrosion. **DO NOT** apply oil to the stainless steel brake strip.

Check all fasteners for tightness including the floor rail fasteners, wall/ceiling rail fasteners, and tubearm screws.

Verify the travel stops are in good functional condition.

Verify that all the locks are holding and releasing properly.

Check the SID markers as required.

Inspect electric cabling for damage.

### **6.2.2 Collimator**

*Refer to the collimator recommended routine maintenance*

Inspect collimator cable for fraying or damage.

### **6.2.3 X-Ray Tube**

*Refer to the x-ray tube recommended routine maintenance*

Inspect the housing for possible oil leakage.

Assure that the housing is tightly fastened to the tube mount and collimator.

Inspect stator cable for fraying or damage.

Inspect high voltage cable ends for carbon tracking. Clean and re-grease HV Cable ends annually.

## 7 Diagnostics

The most common failures in Tubestand operation are related to the electromagnetic locks and the associated wiring. Section 6, *Recommended Maintenance*, and the following diagnostics provide the test sequence needed to isolate and identify component failures in these circuits.

### 7.1 Tubestand Lock, Failure, Switches, and Wiring Chart

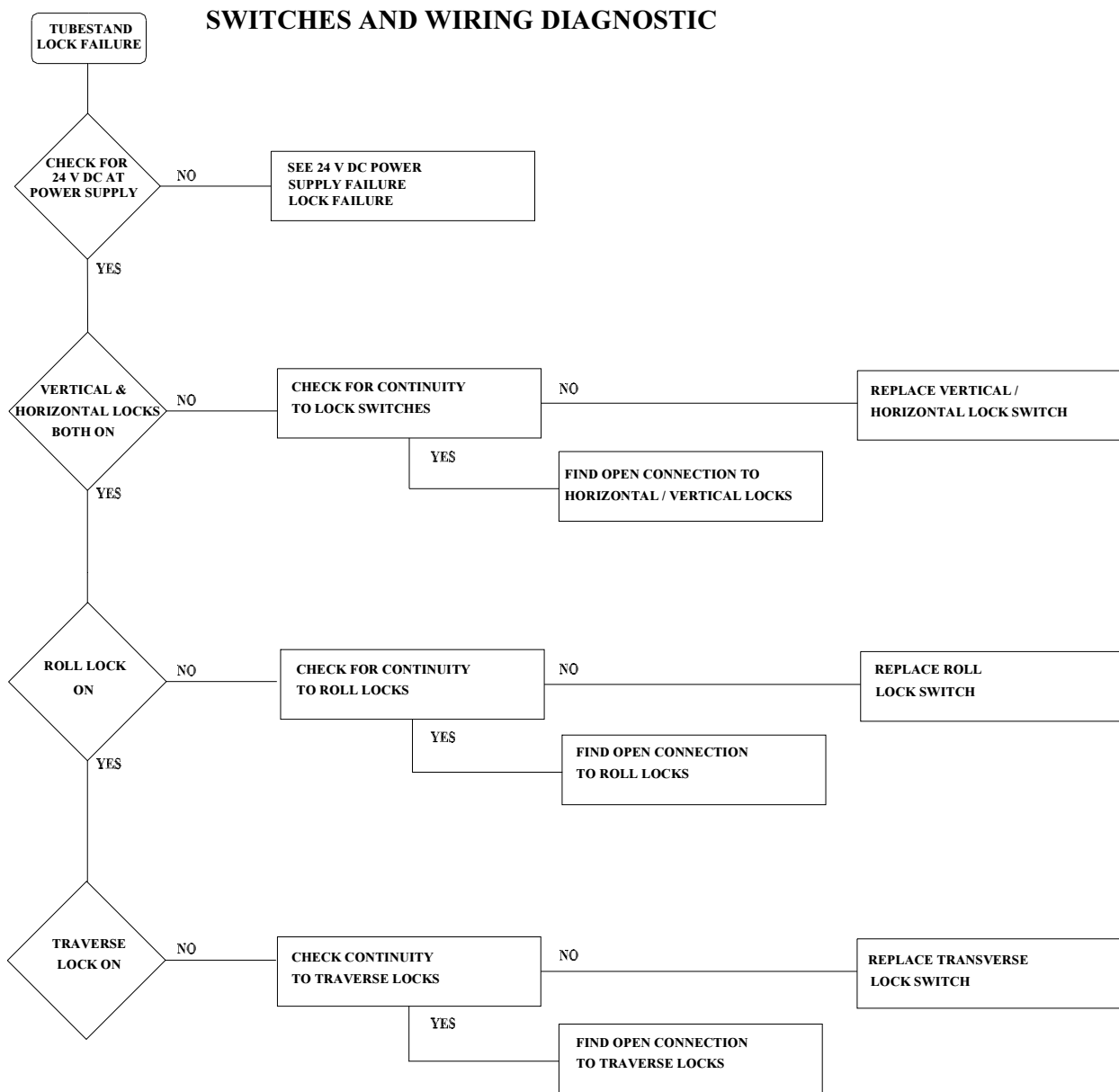

7.2 Tubestand Lock Failure, Lock Coil

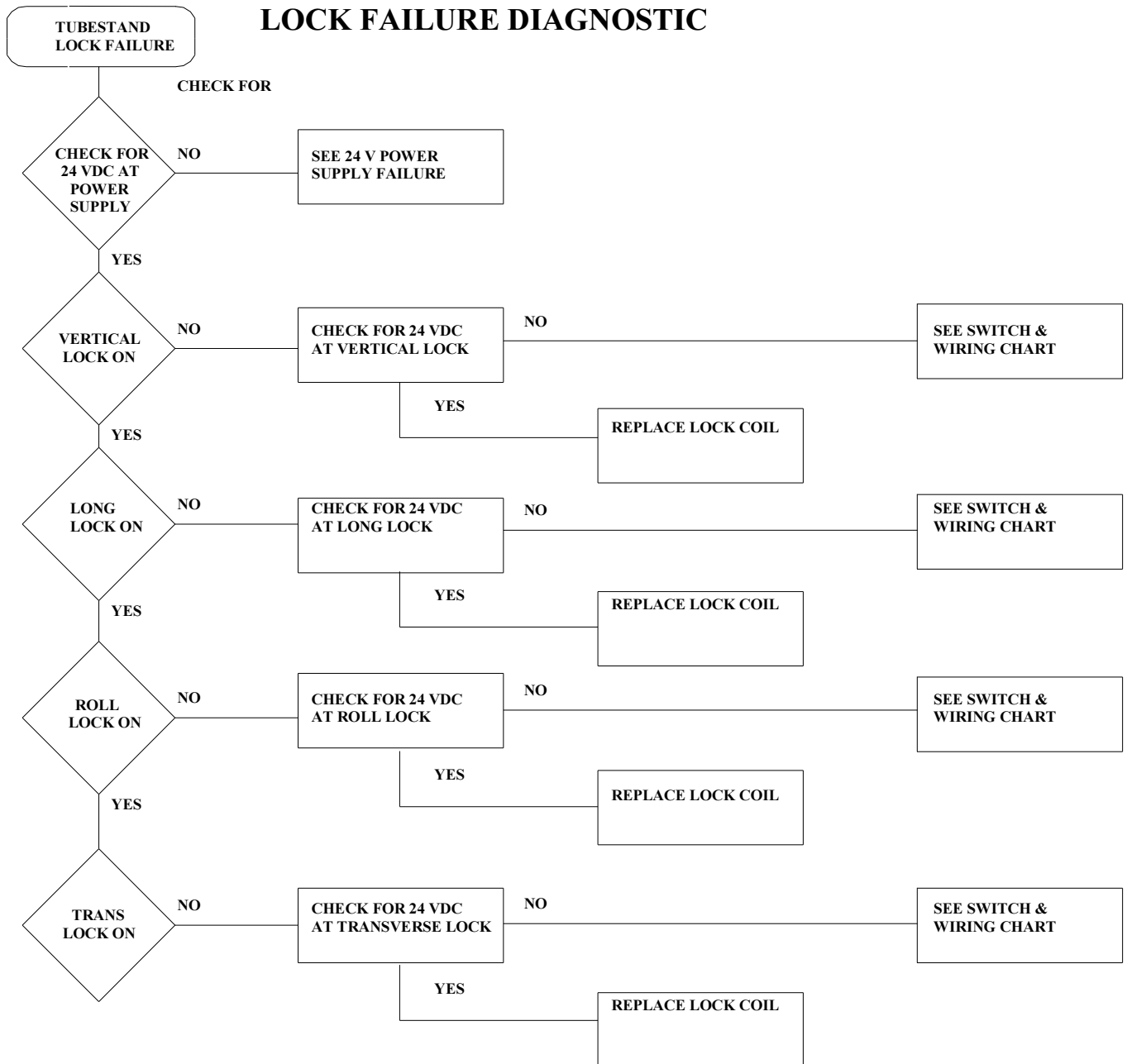

## 8 Drawings and Figures

The following pages are part of the installation information and should be used with the text as appropriate. Attached documents are:

	<u>Page</u>
8.1 Figure 1 - Rail Mount Kit Bill of Materials .....	8 - 2
8.2 Figure 2 - Tubestand Dimensions .....	8 - 3
8.3 Figure 3 - Tubestand - Foot End View .....	8 - 4
8.4 Figure 4 – Floor Car Assembly .....	8 - 5
8.5 Figure 5 - Trim Weights Addition .....	8 - 6
8.6 Figure 6 - Column Adjustments .....	8 - 7
8.7 Figure 7 – Components' Identification .....	8 - 8

8.1 Figure 1 - Rail Mount Kit Bill of Materials

<u>QUANTITY</u>	<u>DESCRIPTION</u>
5	Star Floor Anchor
3	Plug, 1-1/8" Hole
5	SHMS - 3/8" - 16" X 1"
20	Shim - 0.03" Thick
10	Shim - 0.06" Thick
5	Flat Washer - 3/8"
5	Split Lock Washer - 3/8"
8	Internal Lock Washer 5/16"
8	BHMS - 5/16" - 18" X 1"
4	Horizontal Stop Assembly

8.2 Figure 2 - Tubestand Dimensions

**FLOOR MOUNT TUBESTAND ROOM LAYOUT**

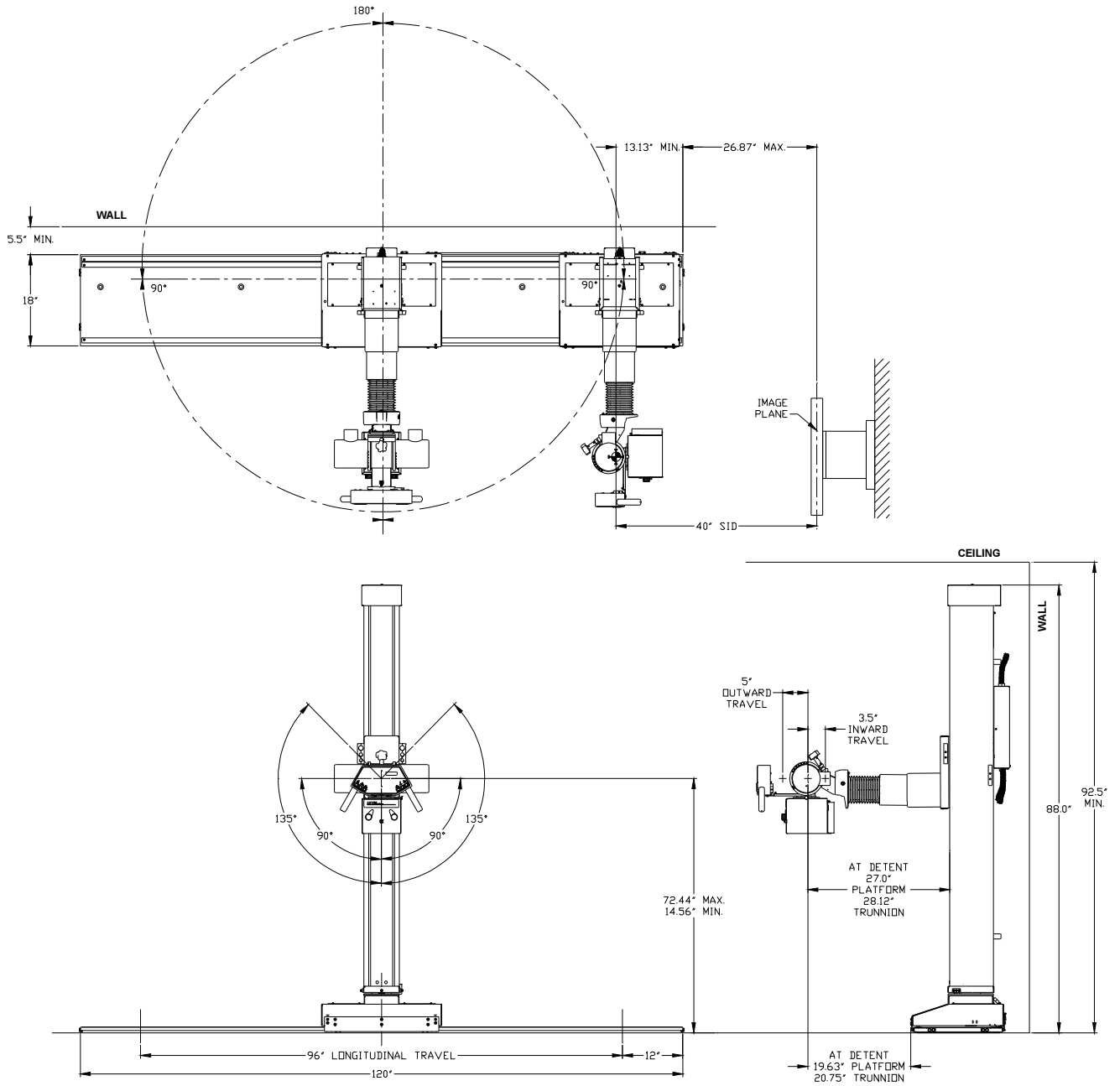

8.3 Figure 3 - Tubestand Foot End View

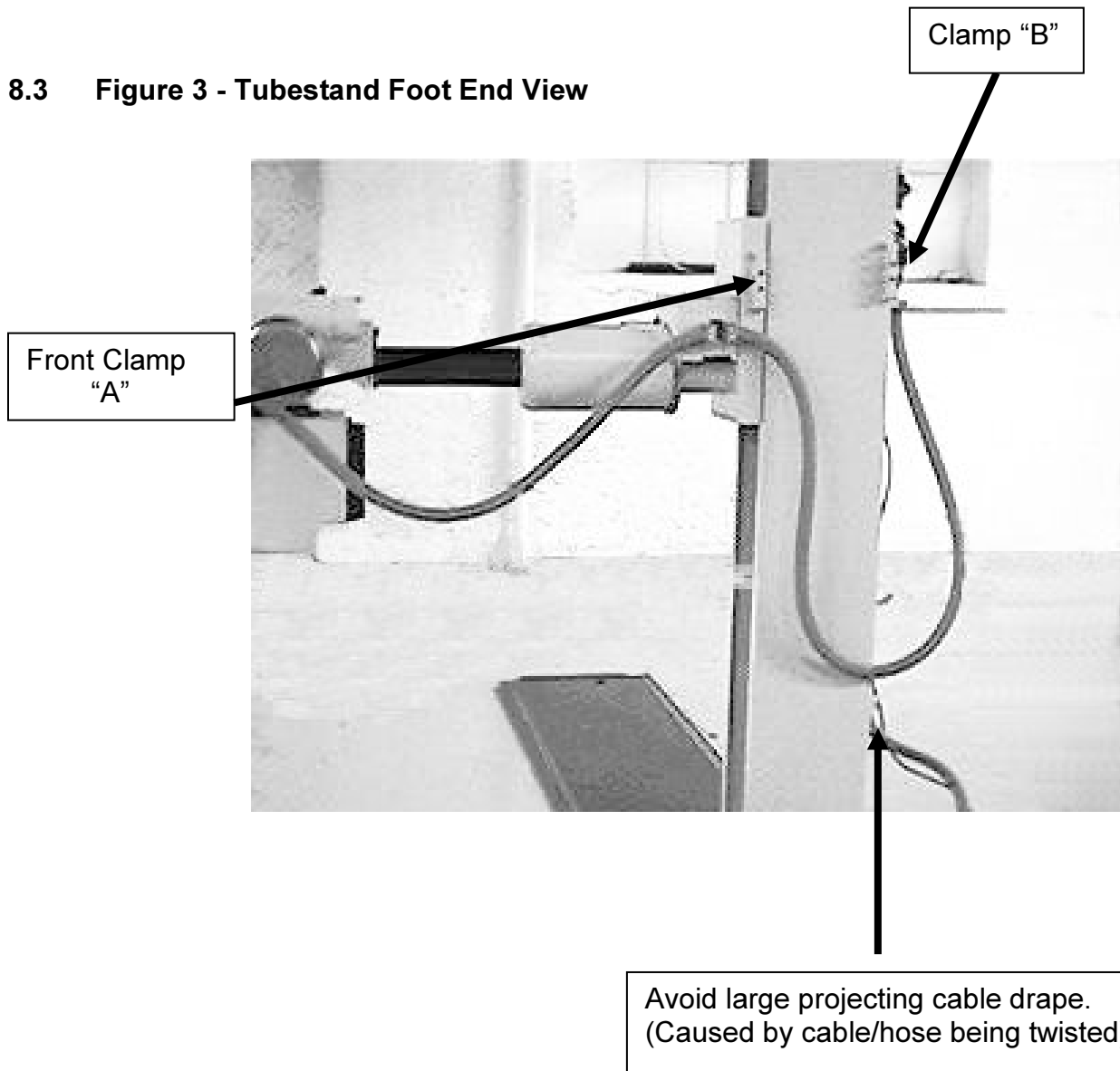

8.4 Figure 4 – Floor Car Assembly

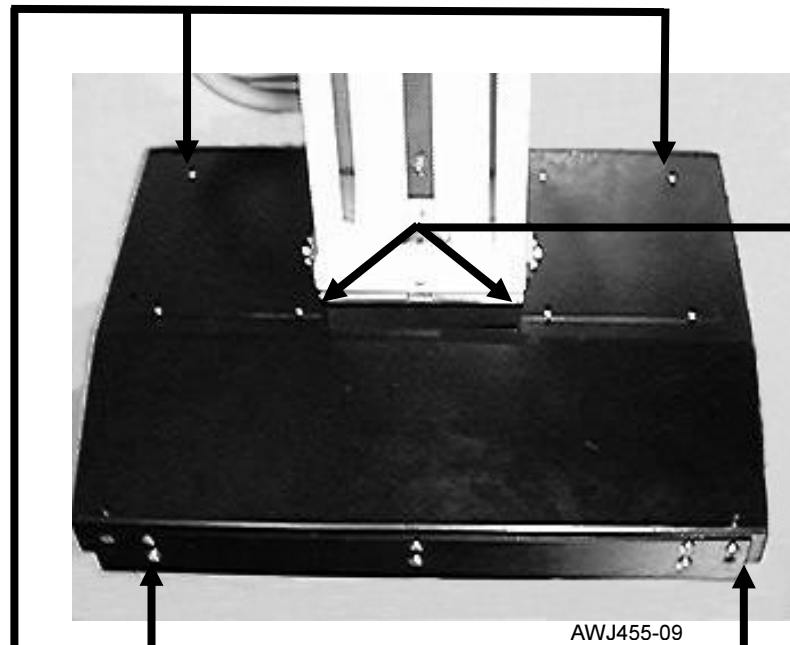

Column Rotation Adjust  
in 4 places.

Bearing Assembly Leveling Screws,  
Typical of 4, 2 in Front, 2 in Back  
(Rear screws not visible in this view)



AWJ455-10

8.5 Figure 5 – Adding Trim Weights

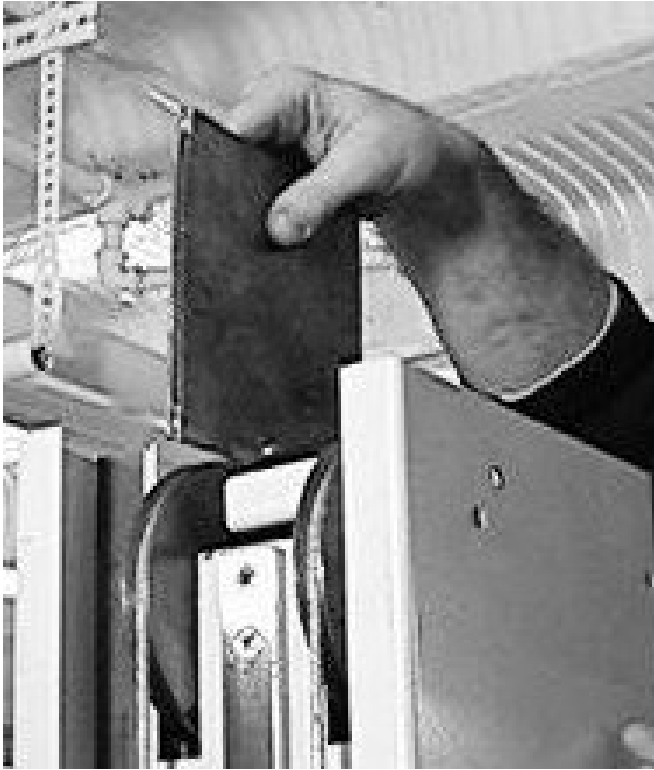

8.6 Figure 6 - Column Adjustments

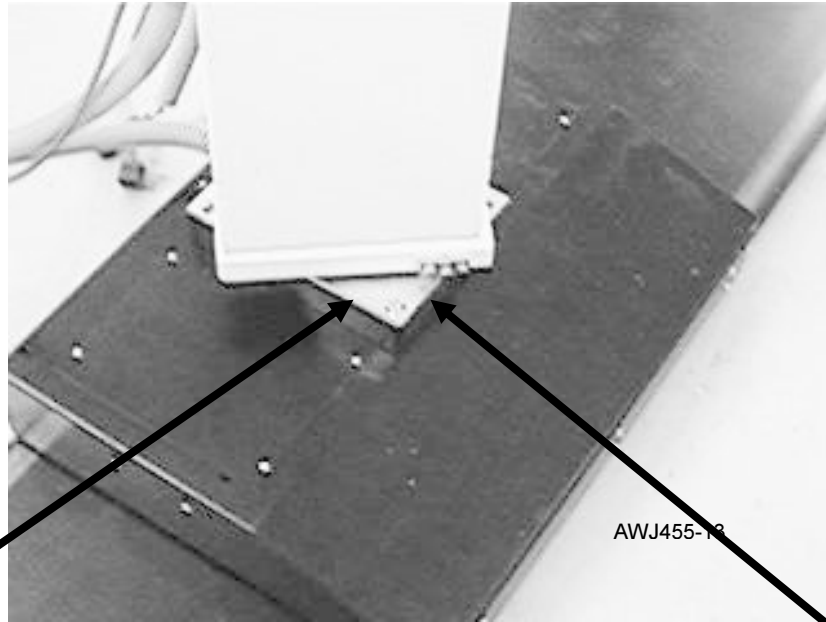

Column Rotation Adjustment  
(Typical of 4, one on each corner)

Column Rotation Tension Screws  
(Typical of 2, one on opposite side)



8.7 Figure 7 – Components' Identification

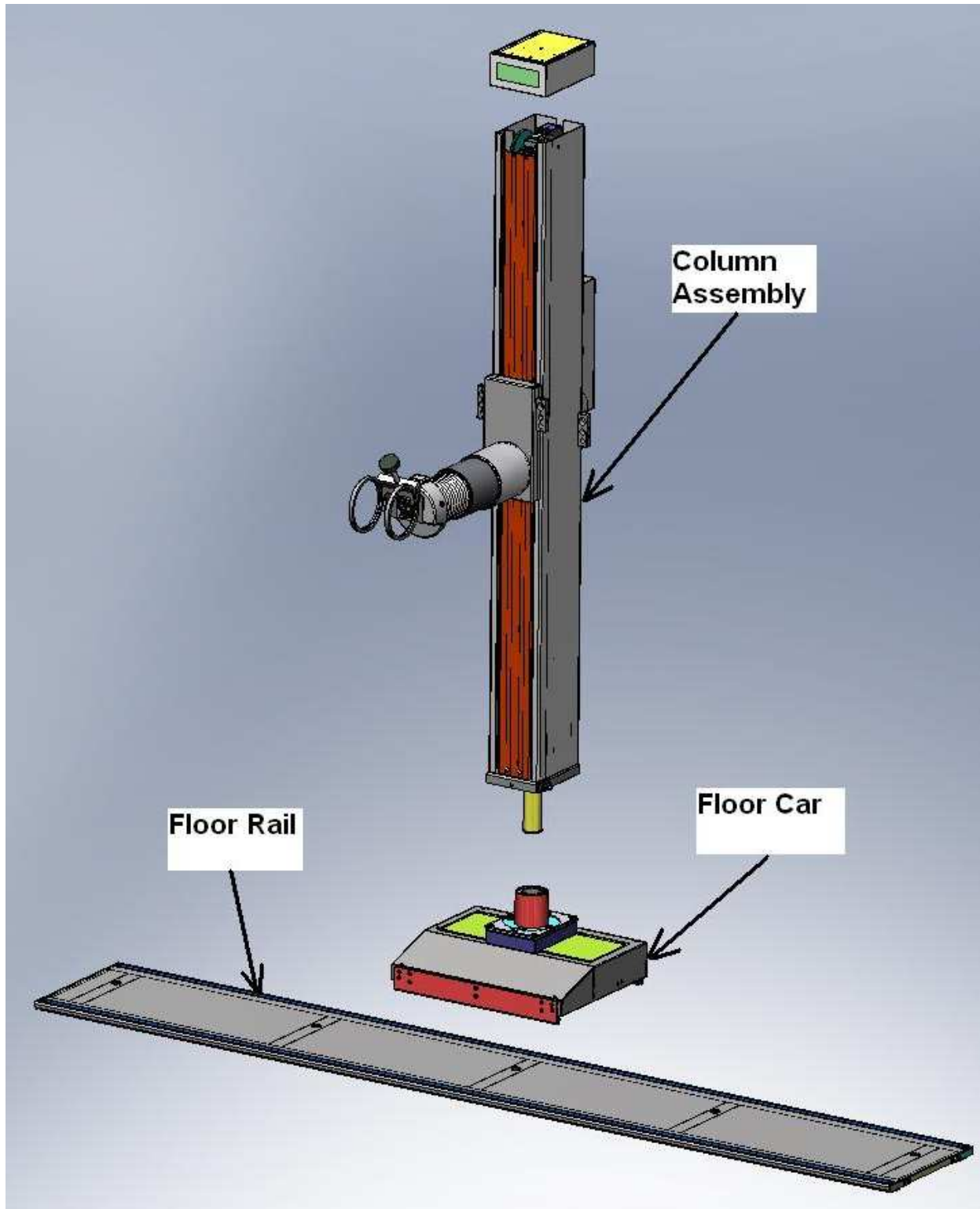

## 9 Users Section

### 9.1 Controls

The picture below shows the operator's control of the Floor Mounted (FM) Tubestand. Each control is keyed to the following list.

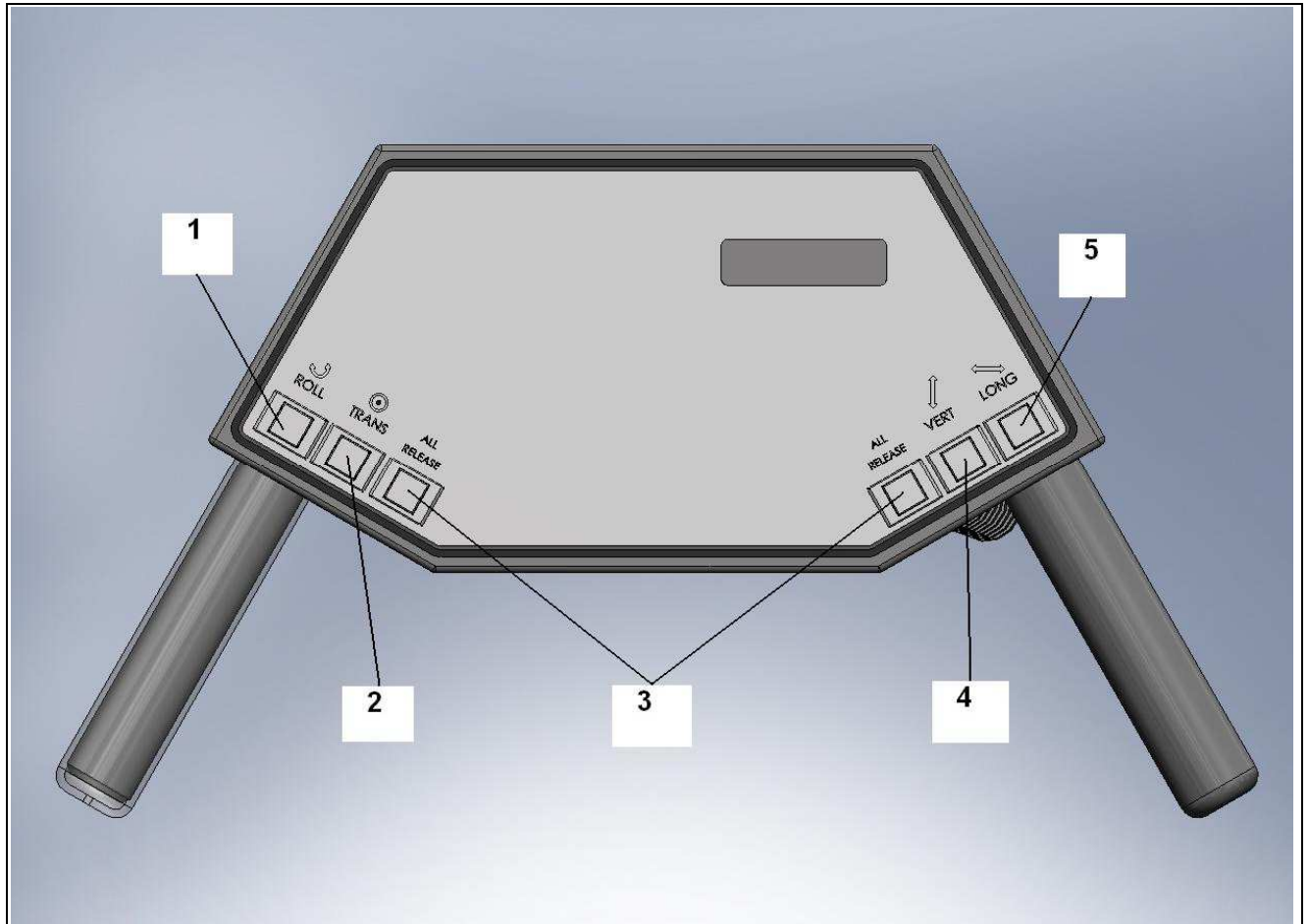

Operator's Control

Number	Control	Function
1	<b>Roll Lock Release Switch</b>	Rotation about the tube's horizontal axis is called "roll". The tube may be turned to any "roll" position and locked. Depress this switch to release the lock, and then roll the x-ray tube slowly into the desired position (a mechanical "detent" is provided to assist positioning at 90 degree increments). Release the Roll Lock Switch to secure the x-ray tube at the desired angle.
2	<b>Transverse Lock Release Switch</b>	Depress this switch to release only the transverse lock. Use this action when you want to move the x-ray tube transversely without disturbing other positioning. Release the switch to lock the Tube Stand in the desired transverse position.
3	<b>All Locks Release Switch</b>	Depress this switch to release all electromagnetic locks that secure all Tube Stand motions (except the "ROLL" motion). The x-ray tube may now be moved in any direction, including vertical. Release the switch to re-engage all locks.
4	<b>Vertical Lock Release Switch</b>	Depress this switch to release only the vertical lock. Use this action when you want to move the x-ray tube vertically without disturbing other positioning. Release the switch to lock the Tube Stand in the desired vertical position.
5	<b>Longitudinal Lock Release Switch</b>	Depress this switch to release only the longitudinal lock. Use this action when it is desired to move the x-ray tube longitudinally without disturbing other positioning. Release the switch to lock the Tube Stand in the desired longitudinal position.

## Model FM Tubestand

---

In addition to roll, vertical, transverse and longitudinal travel, the FM Tube Stand is designed to allow the x-ray tube to rotate about the vertical axis (Column Rotation). Turn the whole tube arm either to the left or right to rotate the tube column about its vertical axis. The detent has stopping positions at the four 90° yaw positions.



Position #1



Position #2



Position #3

### Column Rotation



**CAUTION:** X-Ray exposures should not be performed in other than a “locked” 90° yaw position. The tube position may drift if not locked at one of four 90° points. Tube drift during exposure may result in an unusable radiograph.

## Model FM Tubestand

---

This Tubestand is available with either Trunnion mount or Port-Style tube mount. If equipped with Trunnion rings, in addition to roll, vertical, transverse, longitudinal travel and column rotation, the FM Tube Stand is designed to allow the x-ray tube to rotate about the horizontal axis (Trunnion Movement). To rotate the tube about its horizontal axis, turn the lock knob counterclockwise to loosen. Align the marker on the tube with the desired angle indicated on the tube-mounting ring. Turn the lock knob clockwise to tighten.

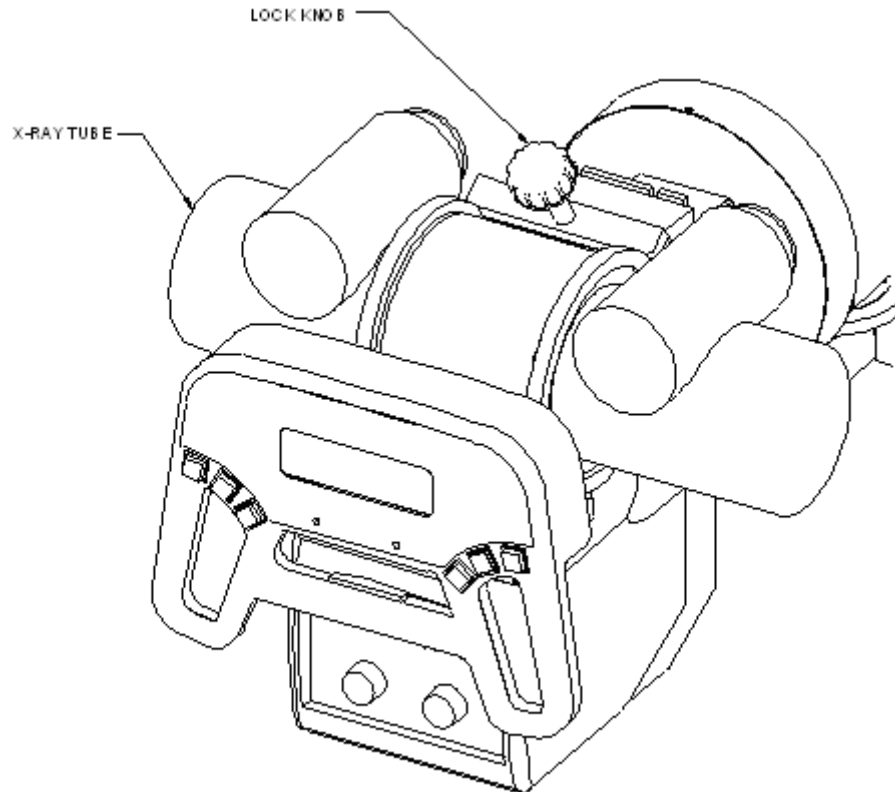

### Trunnion Lock Release



**CAUTION:** X-Ray exposures should not be performed in other than in a “locked” position. The tube position may drift if not locked. Tube drift during exposure may result in an unusable radiograph.

9.2 SID Markers

Adhesive backed markers are provided and located during initial installation of the FM Tube Stand to indicate the SID (source to image distance) to wall receptor or wall mounted cassette holders. Markers showing standard distances of 40 inches (100 cm) and 72 inches (180 cm) are furnished.

Stick the labels (40 and 72 inches) to the Floor Rail at the appropriate place marked by the pointer.

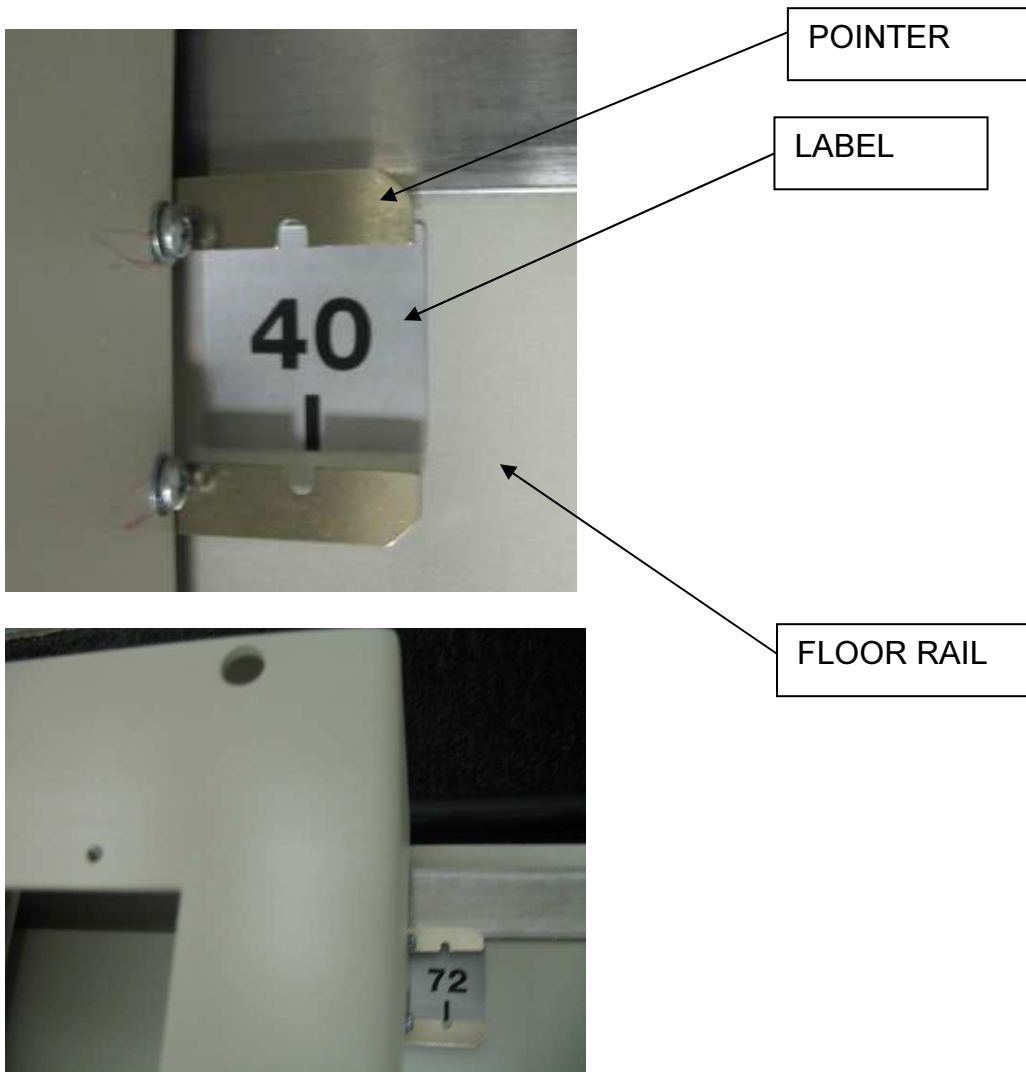

SID Markers