

S223

Four-way Radiographic Table

Installation and Operation Manual

08299 Rev B

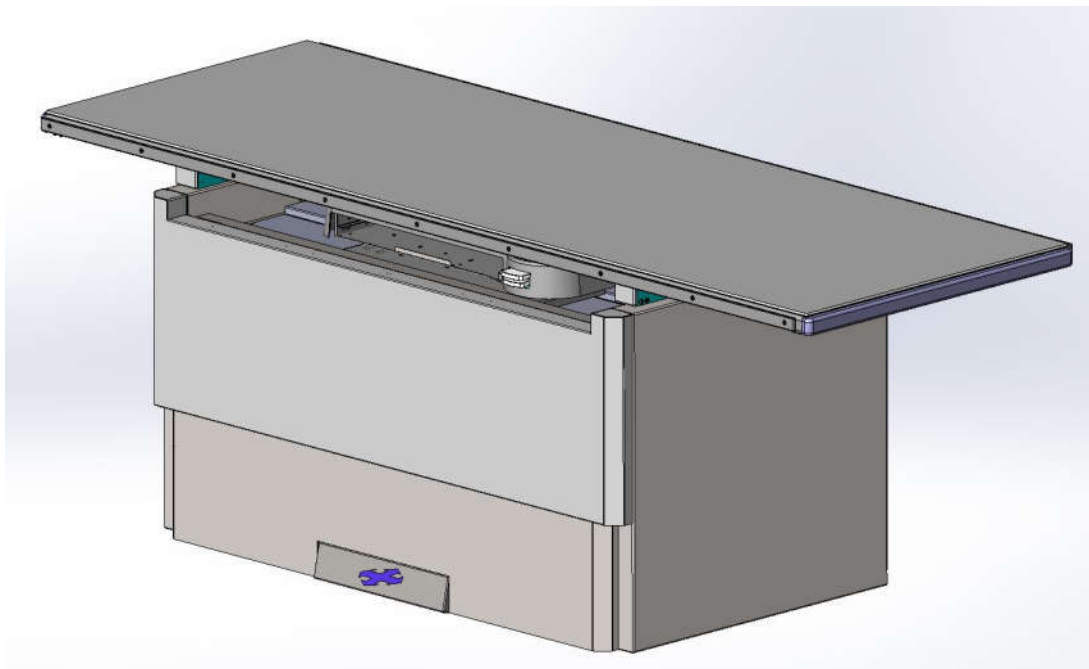

SUMMIT INDUSTRIES, LLC
7555 N. Caldwell Ave.
Niles, IL 60714
773-588-2444
www.SummitIndustries.net

Revision History

Rev	Description	ECR	Released
A	Production Release	10200	4/2019
B	Modify section 1.1 – remove PBL as 5 th receptor option.	10692	7/2021

TABLE OF CONTENTS

1. GENERAL INFORMATION	1
1.1 Introduction.....	1
1.2 Definition of Symbols Used on the Equipment.....	1
1.3 Notices/Safety	2
1.4 Specifications	3
1.5 Shipment and Handling	3
2. PRE-INSTALLATION INFORMATION	4
2.1 Installation Hardware.....	4
2.2 Table Dimensions	4
2.3 Table Clearances	4
3. INSTALLATION	5
3.1 Unpacking.....	5
3.2 Mounting the Table Top.....	6
3.2 Anchoring the Table.....	7
3.3 Electrical Connections	7
4. RECOMMENDED MAINTENANCE	9
4.1 Maintenance Schedule and Inspection.....	9
4.2 Daily Maintenance and Inspection (Operator)	9
4.3 Scheduled Maintenance (Service Personnel).....	9
5. TABLE OPERATION	10
5.1 Table Top Operation.....	10
5.2 Image Receptor Operation	10

1. GENERAL INFORMATION















1.1 Introduction

The S223 radiographic table has a lockable, floating, table top and has a movable image receptor. Four image receptor options are available:

1. Grid Cabinet
2. Reciprocating Bucky Cabinet
3. Grid Cabinet with AEC (Automatic Exposure Control)
4. Reciprocating Bucky Cabinet with AEC

NOTE: cassette size-sensing for PBL (Positive Beam Limiting) can be used with any of the above options.

1.2 Definition of Symbols Used on the Equipment

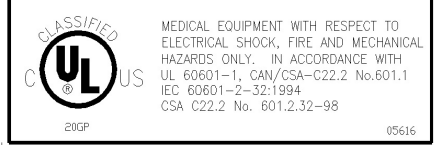
Symbol Legends	
Symbol	Definition
	Date of manufacture
	Manufacturer
	Serial Number
	Reference Number (Model/Part Number)
	Keep Dry
	Refer to the Instruction Manual
 NOTE	This symbol represents Information that assists the user of the manual in the performance of a task. It may provide the user with better methods of conducting the task, or it may point out conditions that could cause the system to fail to operate properly.
 CAUTION	Points out special procedures, or precautions, that personnel must follow to avoid equipment damage.
 WARNING	Identifies situations or actions that may affect patient or user safety. Disregarding a warning could result in patient or user injury.
	TYPE B APPLIED PART This symbol indicates equipment providing a particular degree of protection against electric shock, particularly regarding allowable leakage currents and reliability of the protective earth connection (if present).
	This symbol indicates an Electro Sensitive Device is present which must be carefully handled to prevent damage to the device.
	ELECTRIC SHOCK HAZARD WARNING This symbol indicates an electric shock hazard.
	DANGER VOLTAGE This symbol indicates hazards arising from dangerous voltages.
	DIRECT CURRENT This symbol indicates a direct current source.
	PROTECTIVE EARTH TERMINATIONS This symbol indicates protective earth terminations in device.
	Safety Label

1.3 Notices/Safety

1.3.1 Service and Operation



CAUTION

THIS MANUAL IS FOR USE BY PERSONNEL QUALIFIED TO INSTALL, MAINTAIN, AND OPERATE THIS EQUIPMENT.

Only qualified personnel should install, maintain, and operate this equipment. Familiarize all operators with how to use the system properly. Only qualified service personnel should remove electrical covers or attempt repairs.

The manufacturer does not accept responsibility for any of the following:

Equipment improperly installed, operated, maintained, or repaired.

Equipment which has been modified in any way.

Harm to patient or other personnel for any of the above causes.



WARNING

X-RAY EQUIPMENT CAN BE DANGEROUS TO BOTH PATIENT AND OPERATOR UNLESS PROPER SAFETY MEASURES ARE OBSERVED.

All operators of this equipment should be familiar with regulations and recommendations of industry authorities. These can include:

State Department of Health

Code of Federal Regulations (21 CFR subchapter J Radiological Health)

National Council on Radiation Protection and Measurements (NCRP 33 or successor)

International Commission on Radiological Protection (ICRP 26 or successor)

1.3.2 Radiation Protection

Adequate precautions must be taken to prevent unauthorized or unqualified persons from operating this equipment or exposing themselves or others to its radiation.

All operators of this equipment are to comply with regulations and recommendations of industry authorities (see list, previous section).

The manufacturer, its agents, and representatives do not accept any responsibility for overexposure of patients or personnel to x-ray radiation, including that which is the result of poor operating techniques or procedures.

1.3.3 Servicing the Table



WARNING

HIGH VOLTAGES THAT CAN CAUSE SERIOUS INJURY ARE EXPOSED WHEN THE FRONT PANELS ARE

**REMOVED. DISCONNECT POWER PRIOR TO
SERVICING AND WEAR PROTECTIVE EYEWEAR.**

Only properly trained and qualified personnel should access any internal parts of the x-ray system.

1.3.4 Intended Use

This is an x-ray table, a mechanical device intended to support a patient during a radiographic procedure.

1.3.5 Attenuation

All included components between the patient and image receptor have been certified to comply with 21 CFR Chapter 1 Subchapter J (§1020.30).

1.3.6 Cleaning

It is recommended that any surfaces in contact with a patient be disinfected between uses.

1.4 Specifications

SPECIFICATION SUMMARY TABLE		
Electrical Ratings 115 VAC 50/60 Hz, Single Phase	1.25A	
230 VAC 50/60 Hz, Single Phase	0.60 A	
Maximum Patient Load	Standard	400 lbs / 181.4 kg
	Heavy Duty	650 lbs / 272.2 kg
Environmental Conditions for transport, storage, and operation	Temperature: 40° F to 100° F (10° C to 40° C) Relative humidity: 5% to 95%, non-condensing Atmospheric pressure: sea level to 8000 feet(700 – 1100 hPa)	
Information regarding potential EMC interference and advice for avoidance	<ul style="list-style-type: none"> Main power quality should be that of a typical commercial or hospital environment Power frequency magnetic fields should be at levels characteristic of a typical location in a commercial or hospital environment 	
Degree of protection against harmful ingress of water	IPX0 (No protection)	
Degree of protection against electric shock	Class I, Type B Applied Parts 	
Equipment not suitable for use with flammable anesthetic mixture with air or with oxygen or nitrous oxide.		
Table Physical Dimensions and Weights		
Travel, Table top	28 in. longitudinal (±14); 10 in. transverse (±5)	
Size/Weight, Table top and base assembled (standard)	84 x 31 x 32h in.; 402 lbs.	
Distance, image plane to table top	2.75 in. (standard); 3.25 in. (AEC)	
Crated Size/Weight, table base	56 x 36 x 38h in.; approximately 430 lbs.	
Crated Size/Weight, table top (standard)	87.5 x 34.5 x 4h in.; approximately 100 lbs.	

1.5 Shipment and Handling

Exercise caution when moving and unpacking equipment. It is recommended to leave equipment on its skid until it has been moved to the installation site.

Once delivered, inspect the table for any obvious or concealed damage. It is the responsibility of the dealer to make all shipping claims as all equipment is shipped FOB from the factory.

If it is necessary to store the table before delivery to the installation site select a dry location with moderate temperatures.

Open the crates and cartons carefully. Do not dispose of them until you have located all parts and the machine is fully assembled.

2. PRE-INSTALLATION INFORMATION

Ensure adequate space for the full range of table top motion.

Conventional radiographic room construction should be used. Consult the State Health Department and local building codes for specific radiation shielding requirements.

2.1 Installation Hardware

Two floor anchors are required for mounting to the floor and are NOT provided. Select appropriate hardware for the materials present at the installation site. See Figure 2 for mounting hole locations.

2.2 Table Dimensions

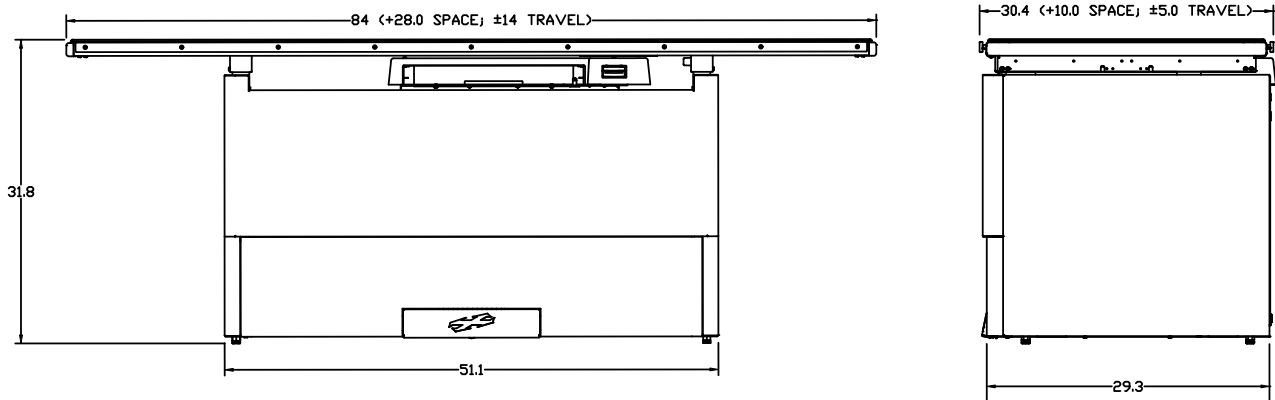

Figure 1

2.3 Table Clearances

Do not obstruct the full travel of the table top in any direction. See Figure 2 for recommended clearances.

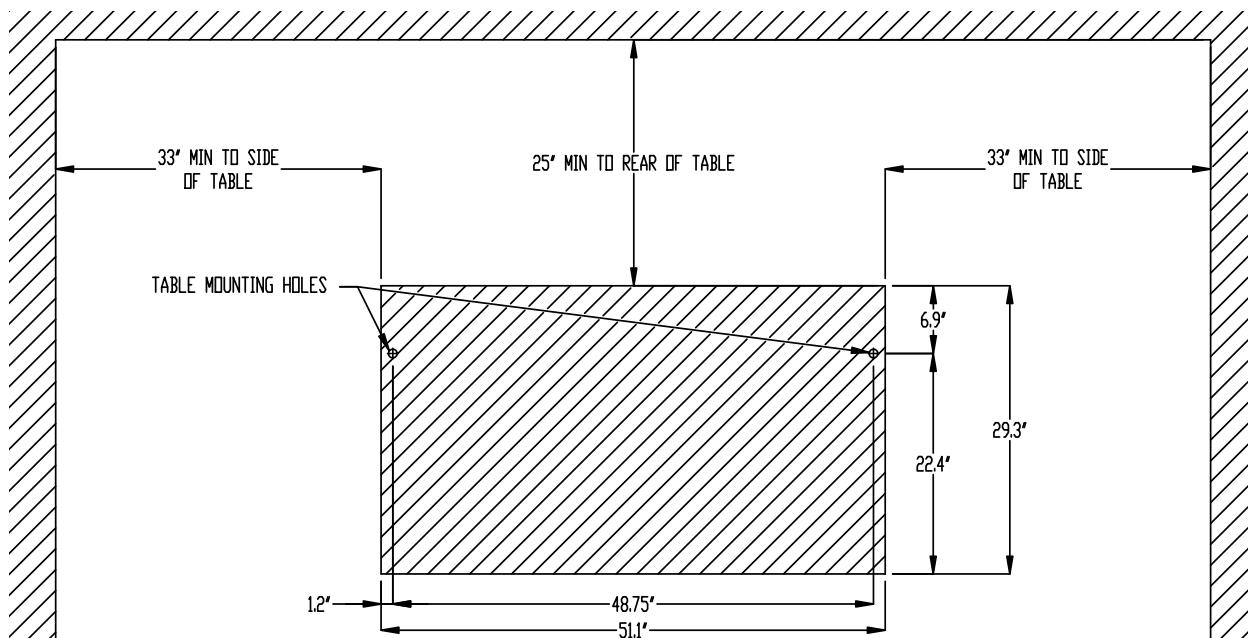

Figure 2

3. INSTALLATION

Table installation should be performed after installation of the tubestand, collimator, and x-ray tube. Separate manuals are provided with these items.

To save space, the compact version of the high voltage generator power module and the transformer tank can both be placed inside the table.



NOTE

The tabletop is packaged separately and must be installed from one side of the table. Ensure adequate clearance for this operation. It may be necessary to assemble the tabletop before fastening the table to the floor.

3.1 Unpacking

1. Remove the crate lid and sides and any packing material from the pallet.
2. Remove the table base from the pallet:
 - a. Remove the upper front panel of the table. Access the two captive mounting #2 Phillips screws through the holes at the lower corners as shown in Figure 3. After loosening the screws completely, lift to unhook the panel at the top.



WARNING

**WHEN REINSTALLING THE UPPER FRONT PANEL,
KEEP FINGERS CLEAR OF THE BOTTOM OF THE
PANEL TO PREVENT PINCHING.**

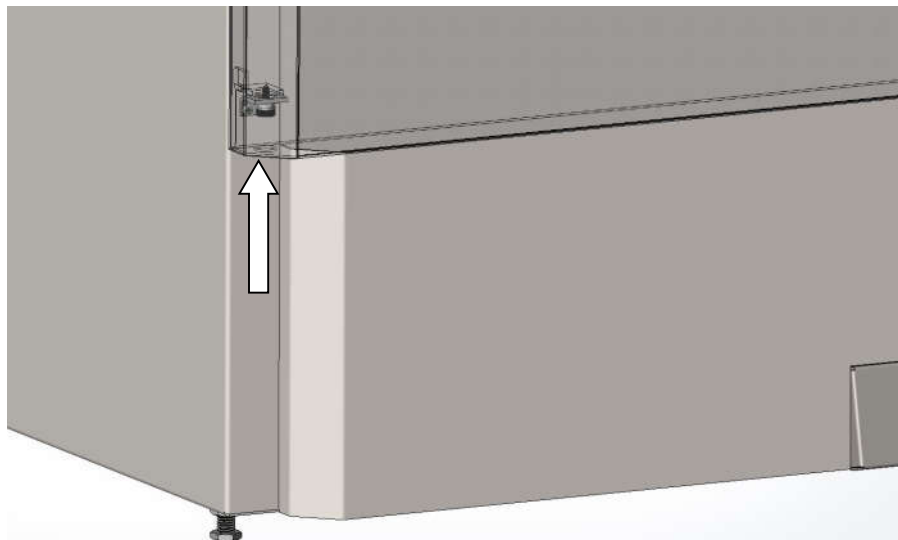

Figure 3

- b. If necessary, the lower front panel may be removed by unplugging the foot switch cable, removing the two screws on each side as shown in Figure 4 and then pulling the panel outward away from the table base.

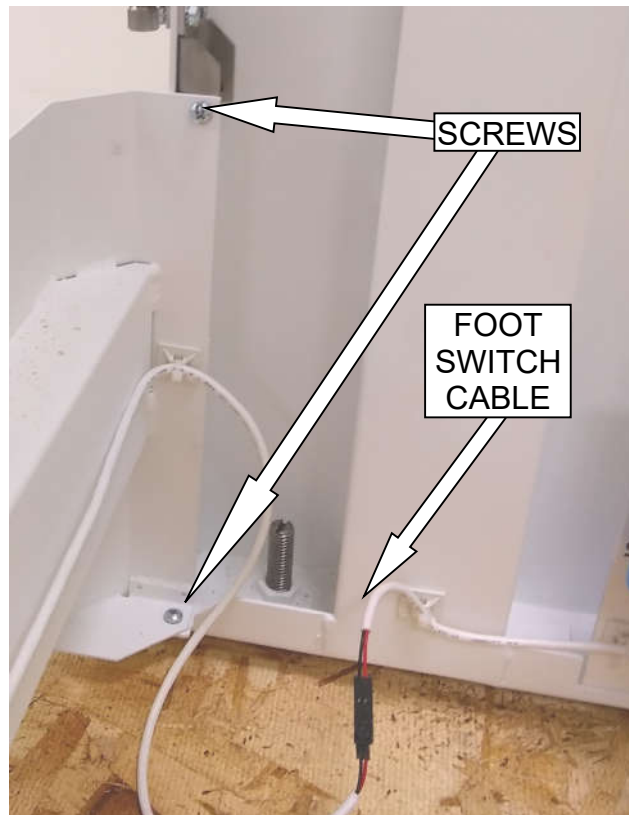

Figure 4

- c. Remove the bolts securing the base to the pallet and remove the table from the pallet.

3.2 Mounting the Table Top



NOTE

Check wall clearance prior to mounting the table top and anchoring the table as it can only be assembled from one of the sides of the table. The table top may also need to be moved partially off the base to verify centering of the beam to the image receptor.

1. Remove the plastic table trim cap and end stop bracket on one side of the table top.
2. Remove the longitudinal lock assembly by removing the two screws that mount it to the table top bearing module of the table base.
3. With the longitudinal brake strip oriented toward the BACK of the table slide the table top onto the table top bearing module.
4. With the table top transverse locks turned off, slide the table top around its full range of motion to ensure it moves freely.
5. Check for vertical and transverse clearance between bearings and table top channel. If clearance is too great or too small, adjust the bearings as necessary (see Figure 5).
6. Replace the end stop bracket and the trim cap. Apply non-permanent thread locking compound (such as Loctite Blue 242) onto the threads of the longitudinal lock mounting screws and reattach the lock assembly.

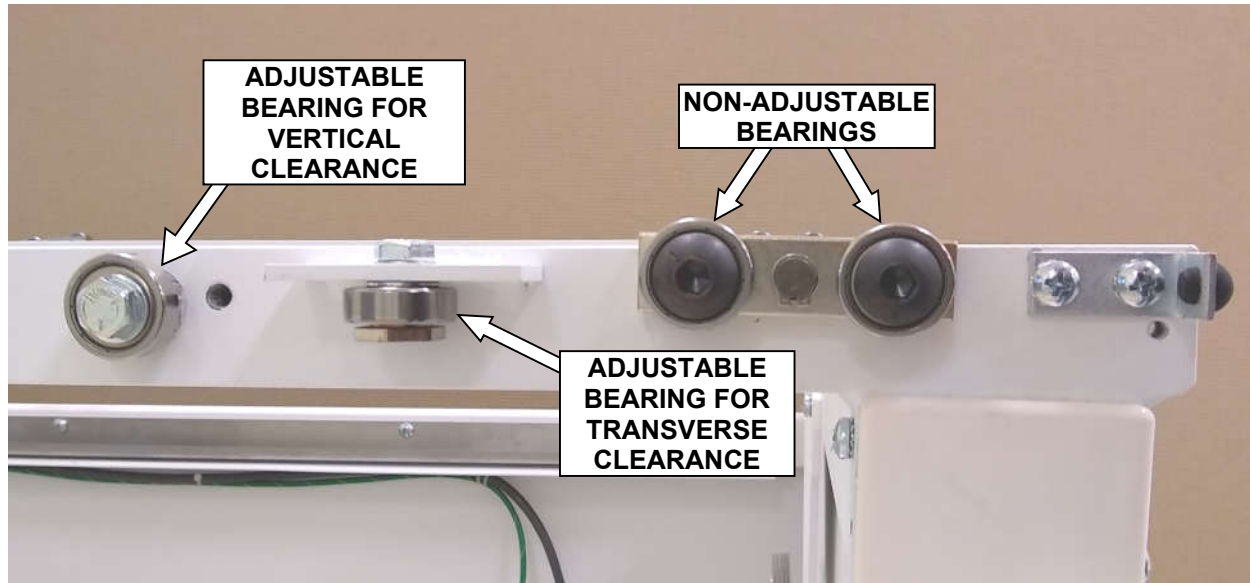

Figure 5

3.2 Anchoring the Table

To ensure patient safety the table must be anchored to the floor. See Figure 2 in the Pre-Install Information section of this manual for both the mounting pattern and clearances. Before anchoring, ensure that the table base is parallel to and the proper distance from the tube stand floor rail. This will greatly improve the x-ray beam to receptor alignment across the horizontal travel.

If the floor is concrete, secure the table to the floor with 5/16" expansion anchors. If the floor is not concrete, drill holes through the floor and secure with appropriate anchors. Minimum pullout force of any anchors used must exceed 500 lbs. Install all anchor bolts as recommended by the anchor bolt manufacturer.

3.3 Electrical Connections

Connect the incoming ground cable prior to connecting Bucky, AEC, accessories, etc.



WARNING

TO ENSURE PROPER GROUNDING AND REGULATORY COMPLIANCE THE SUPPLIED INCOMING GREEN/YELLOW WIRE MUST BE CONNECTED TO EARTH GROUND.

Use the line voltage selection switch at the rear of the table (above the IEC power inlet) to select the correct voltage (115V or 230V) for the supplied power. Connect the table to a standard wall outlet or fused disconnect. See section 1.4 Specifications for current draw.

Any optional AEC or bucky cable connections will plug into the generator as detailed in the generator manual.

3.4 Adjustments and Verifications

3.4.1 Transverse Locks

The transverse lock assembly is factory-adjusted and not intended to be adjusted in the field.

If transverse lock access is needed:

1. Slide the film cabinet to the end of its travel away from the lock to access.
2. Remove the table top end stop/cap on the same side as the lock to access and slide the table top halfway off to expose the inside panel.
3. Remove the access panel on that side to expose the lock assembly (Figure 6).



Figure 6

3.4.2 Longitudinal Lock

The longitudinal lock assembly is set at the factory and does not require field adjustment. To access it for service it is located at the rear right of the table top module.

3.4.3 Cabinet Lock

1. Loosen lock nuts (see Figure 7 or 8). NOTE: The lock appearance will differ based on the model of the cabinet, but the adjustment mechanism is the same.
2. Turn adjustment screws to raise or lower the magnet.
3. The magnet should be as close to the brake strip as possible without touching or dragging.
4. Tighten lock nuts.
5. Move Film Cabinet in both directions to ensure smooth travel.

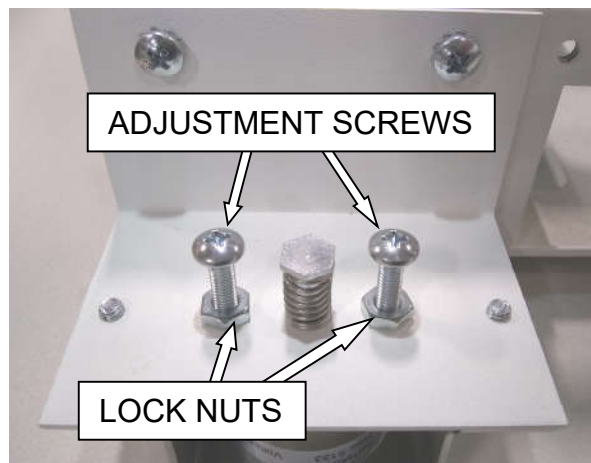

Figure 7

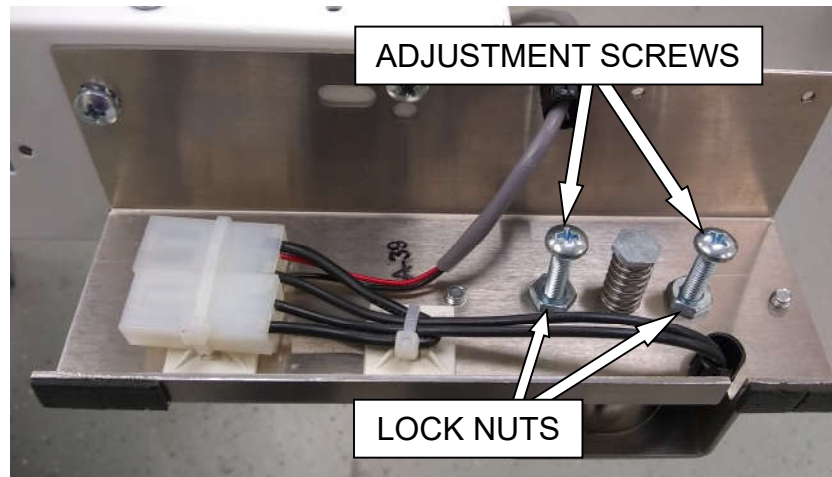

Figure 8

4. RECOMMENDED MAINTENANCE

4.1 Maintenance Schedule and Inspection

Safe performance of the S223 table requires daily inspection by the user and scheduled service by qualified X-ray equipment service personnel. Consult the factory for technician recommendations if necessary.

4.2 Daily Maintenance and Inspection (Operator)

1. Clean up any spills.
2. Visually inspect for damage and general wear.
3. Gently push on both the tabletop and the grid or bucky cabinet to verify that the electric locks are working properly.
4. Check to see that both the table top and the grid or buck cabinet move freely and do not bind with locks off.

4.3 Scheduled Maintenance (Service Personnel)

1. In order to comply with applicable federal and state regulations, the following maintenance schedule must be adhered to:
 - a. First service 30 to 90 days after equipment installation.
 - b. Subsequent service annually.
2. Scheduled maintenance should include, but not be limited to, the following checks:
 - a. Verify proper operation of table top and grid cabinet.
 - b. Inspect all electric locks for proper operation.
 - c. Verify the table top lock foot switch operates properly.
 - d. Verify proper equipment grounding.
 - e. Verify proper anchoring of the table to the floor.
 - g. Inspect all electrical connections for integrity and absence of corrosion.
 - h. Verify all mechanical fasteners remain properly tightened.

5. TABLE OPERATION



WARNING

CARE MUST BE TAKEN WHEN OPERATING THE TABLE TOP WITH A PATIENT ON THE TABLE.

- ❖ Never release the table top locks while the patient is getting on or off the table.
- ❖ Keep patient and operator hands/fingers clear of any moving parts during operation.
- ❖ Avoid sudden movements.

5.1 Table Top Operation

To release the table top locks, press the foot switch. To reactivate the table top locks, release the switch. Ensure that the area around the table is clear of any objects that the table top could hit while repositioning the table top.



NOTE

When there is no power to the table (such as during a power outage or when the table is unplugged) the table will lock in the transverse direction but will still be able to move in the longitudinal direction.

5.2 Image Receptor Operation

The grid or bucky cabinet can be repositioned using its electric lock. To release the lock, activate the lever or button on the cabinet handle. To re-engage, release the lever or button.