

Instruction Manual MTR 225 - MTR 225 DHHS

MANUAL RADIOLOGICAL COLLIMATOR

Confidential Information



Ralco
X-RAY COLLIMATORS



SERIES R 225 DHHS

DATE OF ISSUE:

20.02.2019

REVISION LEVEL:

ISSUED BY:



LEGAL WARNING





THE INFORMATION CONTAINED IN THIS MANUAL IS CONFIDENTIAL. THE CONTENTS OF THIS MANUAL, INCLUDING RALCO SRL SOFTWARE AND THE COLLIMATOR ITSELF CANNOT BE COPIED NOR REPRODUCED IN ANY WAY.

THE CONTENTS OF THIS MANUAL MUST ONLY BE USED FOR THE PROPER INTENDED USE, FUNCTION AND MAINTENANCE OF THE RALCO COLLIMATOR.

RALCO DOES NOT EXPRESSLY OR IMPLICITLY GRANT ANY PROPRIETARY RIGHTS OVER THE RALCO NAME NOR RIGHTS TO MARKET THE RALCO COLLIMATOR BY ANY OTHER NAME.

RALCO SRL WILL PURSUE ANY AND ALL LEGAL REMEDIES AVAILABLE UNDER THE LAW TO RECOVER DAMAGES INCURRED BASED UPON THE ABOVE VIOLATION(S).

Model		Certifications
R 225	STANDARD VERSION	
R 225 DHHS	FDA CERTIFIED VERSION AVAILABLE ON REQUEST	 

Revision Level:

<i>The English version of this manual is a translation of the Italian text which prevails in case of doubts.</i>		
Rev. N	Date	N
A		

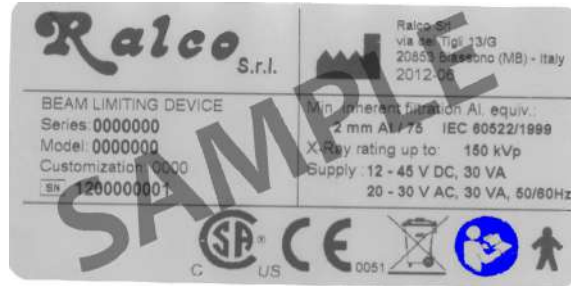

THIS INSTRUCTION MANUAL PROVIDES THE SPECIFICATIONS, DIMENSIONS, AND FUNCTIONS FOR A STANDARD COLLIMATOR. PERSONALIZATIONS ARE AVAILABLE UPON REQUEST. WITH PERSONALIZED COLLIMATORS, THE CUSTOMER MUST ENSURE THE FOLLOWING HAS BEEN PROVIDED:

- YOUR SPECIFIC CODE IS CLEARLY VISIBLE ON THE BACK LABEL AFTER "CUSTOMIZATION", ABOVE THE SERIAL NUMBER, TO ENSURE THE CORRECT PERSONALIZED COLLIMATOR HAS BEEN PROVIDED (SEE ABOVE).
- THE CHAPTER ENTITLED "PERSONALIZATIONS," WHICH INCLUDES RELEVANT INFORMATION REGARDING YOUR PERSONALIZATION.
- OTHER PROVIDED ATTACHMENTS WHICH REFER TO YOUR PERSONALIZATIONS.

CONTENTS

INTRODUCTION	
DESCRIPTION	
CHARACTERISTICS	8
SPECIFICATIONS	
INSTALLATION	
TUBE COMPATIBILITY	15
MOUNTING THE FLANGE TO THE X-RAY TUBE ..	16
ALIGNMENT OF X-RAY TUBE FOCUS AND COLLIMATOR.....	18
Alignment Device	18
Mounting the Collimator to the Flange	19
VERIFICATION OF CORRECT INSTALLATION	22
ELECTRICAL CONNECTION.....	23
Power Supply Connection	23
Wiring Diagram	25
GC-LED-4A.....	26
OPERATION INSTRUCTIONS	
LIGHT/X-RAY FIELD SETTING	30
Front Panel	31
CALIBRATION	
CENTERING X-RAY BEAM WITH COLLIMATOR LIGHT	32
Collimator to Focal Spot Alignment (Primary Shutter Cut-Off)	33
LIGHT FIELD TO X-RAY FIELD ALIGNMENT	33
LIGHT FIELD CALIBRATION.....	34
Vertical Alignment.....	34
Longitudinal Alignment (Long)	34
Light Field Adjustment	35
Vertical Alignment.....	35
Transversal Calibration (CROSS).....	35
COMPLIANCE VERIFICATION	
MINIMUM FILTRATION REQUIREMENT	36
Visual Determination of Half-Value Layer (HVL)	37
Quick-Check of Minimum Filtration Requirement at a Particular kVp	37
Standard Absorber Method.....	37
VISUAL DEFINITION OF X-RAY VERSUS LIGHT FIELD	38
FIELD SIZE INDICATION.....	38
CROSSHAIR ALIGNMENT	39
CHAPTER- ADJUSTMENTS, PARAGRAPH CROSSHAIR ALIGNMENT	39
LIGHT FIELD ILLUMINATION INTENSITY	39
EMC COMPLIANCE	39
Electromagnetic Immunity for All Equipment and Systems	41
Frequency Range and Level: RF wireless communication EQUIPMENT	41
COVER REMOVAL	
ADJUSTMENTS	
FIELD SIZE INDICATION ADJUSTMENT.....	45
Shutter Dial Adjustment.....	45
CROSSHAIR ADJUSTMENT	45
Friction Brake Adjustment.....	45
MECHANICAL MOTION STOP ADJUSTMENT	46
CLOSED Stop Long and Cross Shutters.....	46
TROUBLESHOOTING	
SUBSTITUTIONS	
LED SUBSTITUTION	49
Replacing the Previous Version LED.....	50
Replacing the New Version LED	51
SUBSTITUTION OF THE ELECTRONIC BOARD FOR LED.....	52
SUBSTITUTION OF THE MIRROR	53
SPARE PARTS	
LABELS	56
OPTIONAL ITEMS	
RO 002 Iron Mounting Flange Spacer	61
RO 012/B Retractable Measuring Tape.....	61
RO 041 Mylar Mirror	62
RO 063 Final Quality Test Report Documentation	62
RO 074 External housing and guide rails in customized color.....	62
RO 077 Light Centring Device to align collimator to detector	63
RO 082 Glass Mirror.....	63
RO 096 Wiring Customization	63
RO 107 Knob Color Customization.....	63
RO 111 Front panel customization	63
RO 203 Self-centering top-cover bracket for Siemens X-Ray tube.....	64
RO 240 Focal-spot to skin spacer	65
RO 242/1 Single Laser Line Projection.....	66
RO 242/2 Two lasers forming a crosshair to center the patient to the collimator: Class 2.....	67
RO 258 Additional Variable Filtration - Manual Selection.....	70
RO 258/1 Additional Variable Filtration - Manual Selection.....	71
RO 318 Resin Rotating Mounting Flange	71
RO 332/A Resin Rotating Mounting Flange..	72
RO 344 Accessory guide rail spacers with reinforced support.....	72
RO 356 Shutter position verified by potentiometer.....	73
RO 369 Resin Rotating Mounting Flange	73
RO 370 Resin Rotating Mounting Flange	74
RO 409 Resin Rotating Mounting Flange	75
RO 441 Resin Rotating Mounting Flange	75
RO 442 Resin Rotating Mounting Flange	76
RO 445 Metal Rotating Mounting Flange	77
RO 452 Asymmetric Longitudinal Shutters ("stitching" application).....	78
RO 456 Metal Rotating Mounting Flange	82

RO 489 Resin Rotating Mounting Flange	82
RO 492 Adjustable Top-Cover Bracket	83
RO 495 Camera assembled internally for patient monitoring	90
RO 525 Customized Knob design	90
RO 530 Resin Rotating Mounting Flange	91
RO 586 Single Laser Line Projection.....	92
RO 587/2 Two lasers forming a crosshair to center the patient to the collimator: Class 1..	95

MAINTENANCE

CLEANING RECOMMENDATIONS	99
DISINFECTION	99
RECOMMENDED MAINTENANCE PROGRAM	99

GENERAL

WARRANTY.....	101
REPAIRS.....	101
END OF LIFE DISPOSAL	102
DISASSEMBLY	102
TRANSPORT AND STORAGE	102
SAFETY/RESPONSIBILITY	103
RESIDUAL RISKS.....	104

INTRODUCTION

General Safety Information

Ralco products are designed and manufactured to meet the international safety standards for medical equipment. However, all medical electrical equipment requires proper installation, operation and servicing, particularly with regard to human safety.

Read, note, and strictly observe all safety tags on the equipment. Strictly observe all safety directions, all warnings and all cautions that are mentioned in this chapter and throughout this service documentation. In order to protect the personal health of service personnel, operators and patients, ensure the safe servicing and operation of the system.

Intended Use of the Collimator

This collimator is designed to be used with a Radiological system producing ionizing radiation for medical or veterinary use. Whomever is authorized to operate or service the radiological equipment must be thoroughly familiar with the procedures related to radiation protection and equipment use and maintenance.

Ralco is not responsible for any personal injuries or damage to property from misuse or unintended use of this collimator. This manual must be made available to the installer and operator.

Installer and Operator Responsibility

The installer and operator must verify that ALL safety standards are followed immediately after installation of the collimator and before any subsequent use. All procedures regarding the installation and safe use of this collimator must be strictly followed.

X-ray equipment manufacturer responsibility

If the X-ray equipment manufacturer does not use the READY signal, allowing X-ray exposures regardless of collimator state or status, all liability falls upon the X-ray equipment manufacturer. In the event of any emergency and the READY or ERROR signals are bypassed allowing X-ray exposures, all the liability falls upon the X-ray equipment manufacturer.

The collimator electronics supplies a signal defined as READY. The X-ray equipment manufacturer will manage this signal as the X-ray consent. In the event of a collimator failure, the liability for the correct bypass of this signal, in order to always ensure the X-ray consent, devolves upon the X-ray equipment manufacturer.

Reporting

Information regarding accidents that have occurred while using this collimator must be reported immediately to Ralco, srl.

Limitation of Liability

Ralco is not liable if the provided instructions are not complied with. Furthermore, Ralco is not liable if one or several of the following instances apply:

If the unit is specifically designed per client specifications and the certification was the duty of the client;

The collimator was modified in any way by the OEM or operator;
The collimator was installed without respecting the instructions, as provided in this manual;
The collimator was used in a way outside its intended use;

The collimator was not installed by competent personnel;
The collimator was not operated safely or in a way contrary to the instructions in this manual;
The collimator was not subject to routine inspection and maintenance by competent personnel;
The collimator was repaired with non-Ralco spare parts;

The Collimator was Used in a Way Not Reasonably Foreseen by Ralco

Ralco is not liable for any direct or indirect damage caused if the procedures in this manual are not followed.

The collimator complies with current standards for static load, a non-wearing class. This statement is based on studies and tests performed on the collimator performance and its weight. If the final system, through tilting movements or other dynamic movements, increases the risk factor other than those studied and tested, it is the responsibility of the customer to ensure that there are no dangerous situations.

The collimator described here, is used on Radiological systems and is classified as a type IIB according to Attachment IX. The collimator has been designed and manufactured in compliance to Attachment II of Legislative Decree, 2 February 1997, N. 46, Implementation of Directive 93/42/CEE of 14 June 1993 and successive modifications applying Directive 2007/47/CE.

List Applicable Standards and to which Ralco adheres to:

IEC 60601-1:2005 + Am1:2012 (ed. 3.1), North American market deflections (US+CA)

IEC 60601-1-2:2014 (ed 4)

IEC 60601-1-3:2008 + Am1:2013 (ed. 2.1)

IEC 60601-2-54:2009 + Am1:2015 (ed. 1.1)

IEC 60601-2-45:2011 + Am1:2015 (ed. 3.1) Applicable in Mammography instead of IEC 60601-2-54:2009

IEC 60601-1-6:2010 + Am1:2010 (ed. 3.1) (Usability)

IEC 62304:2006 + Am1:2015 (ed. 1.1) (Software)

IEC 60825-1:2014 (LASER - if applicable)

IEC 62471:2006 (LED - if applicable)

ISO 9001:2015

ISO 13485:2016

21 CFR subchapter J (FDA)
8750 01 & 8750 81 (CSA)

CE

*Ralco can provide documentation regarding its adherence to any of the above standards.

EN 60601-1 par. 5

Protection against electric hazards: "Class I" equipment.

Protection against direct and indirect contacts: Type B equipment with applied parts.

Protection against water see page: "Common equipment".

Safety of operation in the presence of inflammable anaesthetics with air or oxygen or nitrous oxide: Equipment not suited to application in the presence of inflammable anaesthetic mixtures containing air or oxygen or nitrous oxide.

- Operation conditions: Equipment for continuous operation at intermittent loads - See Chapter Operation Instructions.
- Should label data on the collimator not correspond to the specifications herein, inform Ralco of the non conformity.
- Verifications of the specifications are to be performed according to the indicated equipment standards.



Inherent Danger of X-Rays

The collimator has been constructed to current standards to meet the safety requisites of Directive 2007/47/CE and all other applicable standards. However, due to Radiology being an inherent dangerous activity which cannot be completely safe guarded against, it is crucial that all safety procedures are followed. The installer and operator must follow ALL established procedures (including those mentioned in this manual) to reduce the inherent danger of X-Rays.

The inherent risk of using collimators in Radiological systems is deemed reasonable as determined by applicable standards. The use of collimators for Radiological systems is strictly regulated. Ralco follows all applicable standards. It is up to the installer and operator to ensure that all possible steps are followed to ensure the health and safety of the patient and operator.

The contact with the moving parts can be considered impossible and may occur only during installation or maintenance (low hazard). The internal parts are protected by a mechanical safeguard in the form of a metal or plastic sheath which impedes access. Also motor units are not accessible as knobs are fixed using the Allen screws and can be removed only by using a tool, in accordance with paragraph 5.92.3 of EN 60601-1 and EN 60601-2-54 par. 201.9.2.2.5. In addition the collimator has been tested in accordance with EN 60601-1, paragraph 4.8.2



Read all information in this chapter carefully.

You are responsible to take safety precautions and to follow the safety instructions. Thus, you can prevent harm form yourself and other persons.

TECHNICALLY QUALIFIED PERSONNEL ONLY!

- Only technically qualified Field Service Engineers (FSEs) must do the service work. The FSEs must be appropriately and successfully trained and instructed.
- Perform all service tasks such as installation, maintenance, or repair in strict compliance with the provided safety instructions!
- Perform all action as for example unpacking, installation, setting to work, testing and replacement according to the sequence stated in this manual.
- Perform all service tasks in strict compliance with the local regulations concerning safety, health, accident prevention, and medical X-ray devices!
- Never change any system parameters or components that reduce the mechanical safety, electrical safety, radiation protection properties of the product!
- Do not modify this equipment without authorization of Ralco.
Any unauthorized modification can cause malfunction or deterioration of performance and quality and can therefore lead to personal injury, clinical misdiagnosis or clinical mistreatment.
- Never leave problems unsolved that may affect the safety of the product!
- Order spare parts via Ralco distribution channel.
- Always perform all relevant safety checks before handing the product over to the customer!
- Keep in mind that certain details or procedures change since you previously installed or serviced a similar product!

If you do not obey these instructions, there is a risk of death or serious injury.



A temperature of the collimator cover, under normal operating conditions and at the maximum ambient operating temperature (40°C), could exceed 41°C. According to the Table 24 of the General IEC 60601-1 standard, contact with the collimator cover must be less than 1 minute, both for the operator and for the patient. During the diagnostic test the operator must pay attention that the patient does not come into contact with the collimator surface for more than 1 minute.

If you do not obey these instructions, there is a risk of serious injury.

Precautions Against Mechanical Hazards

SAFE HANDLING OR ROTATING MACHINERY

- Never service rotating machinery, bands or chains when rotational movements are activated.
- Make sure that the rotational movements are switched off.
- Make sure that nobody can switch on the movements accidentally.
- Block the movement, if necessary.

Safe handling of tilting machinery

- Never service tilting machinery when tilting movements are activated or brakes are released.
- Make sure that the tilting movements are switched off.
- Make sure that nobody can switch on the movements accidentally.
- Block the movements, if necessary.

If you tilt the machinery during installation or during other service activities:

- Comply with the specific service instructions.
- Ask a second person to release the brake and to keep the tilting movement under control.
- Avoid uncontrolled tilting movement.
- Never release the brake longer than necessary.



Hazard of physical injury caused by heavy loads

- Wear appropriate protective clothing, such as safety boots and gloves.
- Take care that heavy loads are correctly lifted or carried to avoid any physical injury.
- Ask other persons for help to handle very heavy or awkwardly shaped loads.
- Use mechanical devices whenever it is possible.
- Stick to the installation instructions regarding:
 - suitable tools
 - lifting devices
 - lifting/support points
 - particular safety measures

If you do not obey these instructions, there is a risk of property damage.

Safe handling of light source

Light source and adjacent parts can be very hot. They can cause severe burns.

- Never touch the light source, light source socket, or light source bracket with your fingers immediately after use.
- Leave the light source and adjacent parts to cool down before handling them.

Precautions Against Electrical Hazards



Hazard of electrical shock during service tasks

During installation, maintenance, and other service tasks there is a risk of electrical hazards.

- Follow the general instructions provided in this chapter.

If you do not obey these instructions, there is a risk of property damage.

General precautions against electrical hazards

- Switch off the mains supply.
- Make sure that nobody can switch on the system accidentally before you start.
- Make sure that all UPS-powered components are powerless.
- Use a voltmeter to verify that all line disconnects are opened.
- Remove all jewellery, such as bracelets, or rings to prevent short circuits.

Precautions concerning installation and service

Electrical installations of medically used rooms must comply with the requirements of each country.

Follow the instructions provided on the installations sheets for the specific project.

- Always use a separate conductor for ground connection. The neutral conductor is not considered as ground connection.
- Do not use a three-to-two pins adapter to connect equipment provided with a power cord. Always connect the equipment to properly grounded, three-pin power outlets.
- Connect the system to the mains as late as possible during installation.
- Make sure that all protective earth conductors are installed and connected before first switching on the system.
- Always be sure that the power is switched off when installing any parts to the equipment.
- Make sure that the large internal capacitors are completely discharged. Discharging can take several minutes.
- Keep away water or other liquids from the inside or the equipment to avoid short-circuits or corrosion.
- After installation or service work on electrical components the following tests have to be performed to ensure the compliance with IEC 62353:
 - Touch voltage
 - Protective earth conductor resistance
 - Earth leakage measuring

Working when connected to voltages

- Switch off the main power supply when working at the equipment. This rule does not apply for certain measuring and adjustment procedures that are only possible when the product is switched on.
- Never measure or adjust equipment with power-on unless another person is present.
- Be very careful when working close to live contacts.
- Never perform any work on live parts (> 50 V).
- Prevent unwanted or sudden movements of the system because they are dangerous. If the procedure involves mechanical movements, take every precaution especially when working with moving and rotating parts. Use the service switch or the EMERGENCY STOP button before working within the dangerous movement area of a product.
- Check the ground connections before touching conductive system parts.
- Use tools and measuring instruments, which are suitable for the respective procedure only.
- Make sure that test and adjustment points are accessible without any risk of injury. If safe access is not possible, switch off the system.
- Turn off the power supply immediately after finishing the test or adjustment procedure.

Safe handling of high-voltage cables

- When the mains and auxiliary power supplies are disconnected: Wait at least two minutes before removing the flexible high-voltage cables from the X-ray tube housing or the generator.
- Discharge any residual charge before touching the contact pins (briefly connect them to ground).

Precaution Against Material Damage

ENVIRONMENTAL CONDITIONS FOR SAFE OPERATION

- The oxygen content of the ambient air during operation must be lower than 25%!
- The X-ray equipment must not be operated along with combustible anaesthesia substances!
- Ensure that the indoor temperature is within +10 - +40°C.
- Ensure that the indoor relative humidity is within 10 - 75%.
- Ensure that the air pressure is within 700 - 1060 hPa

Cleaning and disinfection

- Do not use aggressive cleaning agents to clean the product!
- When you use cleaning agents such as detergents and disinfectants, make sure that they do not contain explosive substances as they can create explosive gas mixtures!
- Obey the manufacturer's data of the cleaning agent and disinfectant!
- Obey the manufacturer's data of the cleaning clothes!



Malfunction through electromagnetic fields

The equipment fulfils all requirements concerning electromagnetic compatibility (EMC). nevertheless, powerful high frequency transmitters used near the electronic components can cause malfunction of electronic components under unusual circumstances. This malfunctions causes unwanted risks for patients, operators, and service personnel.

- Switch off your mobile phone in designated areas.

If you do not obey these instructions, there is a risk of property damage.



Processor overheating

The processor can get damaged within a few seconds.

- Do not operate the processor without cooling.

If you do not obey these instructions, there is a risk of property damage.



Damage by electrostatic discharge (ESD)

ESD can destroy or partially damage electrostatic sensitive devices such as printed circuit boards (PCB). The damage can lead to instant or later failures of the device.

- Read all the following instructions concerning ESD protection.
- Take all necessary precautions to protect electrostatic sensitive devices.

If you do not obey these instructions, there is a risk of property damage.



The rules concerning ESD protection apply to new devices and old devices and old devices. Old devices are replace and sent back to the service depot.







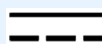



Additional symbols on the collimator (if applicable)



or AC Alternating Current No. 01-14 Ref. IEC 417-IEC 503



or DC Direct Current No. 01-18 Ref. IEC 417-IEC 5031

	or AC/DC Alternating and Direct Current No. 01-19 Ref. IEC 417-IEC 5033
	Protective Ground No. 01-20 Ref. IEC 417-IEC 5019
	Plus, Positive Polarity No. 01-27 Ref. IEC 417-IEC 5019
	Minus, Negative Polarity No. 01-28 Ref. IEC 417-IEC 5006
	Input No. 01-36 Ref. IEC 417-IEC 5006
	Output No. 01-37 Ref. IEC 417-IEC 5034
	Remote Control No. 01-38 Ref.
	Manual Control No. 01-45 ISO 7000-096
	Automatic Control (Closed Loop) No. 01-46 ISO 7000-0017
	Iris Diaphragm: Open No. 01-69 ISO 7000-0017
	Iris Diaphragm: Closed No. 01-70 Ref. 417-IEC 5324
	Radiation Filter or Filtration No. 04-51 Ref. 417-IEC 5381
	Light Indicator of Radiation Field No. 04-51 Ref. 417-IEC 5381
	Beam Limiting Device: Open No. 04-55 Ref. 417-IEC 5385
	Beam Limiting Device: Closed No. 04-56 Ref. 417-IEC 5386
	Beam Limiting Device: Closed with Separate Opening of the Shutters No. 04-57 Ref. 417-IEC 5387
	Beam Limiting Device with Separate Closing of the Shutters No. 04-58 Ref. 417-IEC 5388
	Cassette Size Sensing Device
	Device Requiring Proper Disposal, Attch. 4 Ref. 2002/95/CE



Type B Applied Part No. 02-02 Ref. 601-I-IEC



Follow Instructions for Use Ref. ISO 7010-M002 (see the collimator label)



General Warning Sign No. 03-02 Ref. IEC 601-1



Caution: Laser Radiation Ref. 60825-1

This symbol identifies electrostatic sensitive devices.

- Always transport electrostatic sensitive devices (such as PCB) in their static shielding bags or boxes.
- Always use the ESD protection service kit when handling electrostatic sensitive devices.
 - Attach the wristband to your wrist (1) and connect the ground cable of the wristband to the conductive work surface (2).
 - Connect the second ground cable (3) to the conductive work surface (2).
 - Attach the crocodile clip to a reliable ground of the cabinet or console, where the PCB has to be installed.
- Place the PCB on the conductive work surface before installing them.
- Place the PCB on the conductive work surface for hardware settings or replacement of components.
- Never remove or disconnect the wristband before all electrostatic sensitive devices are installed.
- Never remove or disconnect the wristband before all removed electrostatic sensitive devices are safely packed in their static shielding bags or boxes.

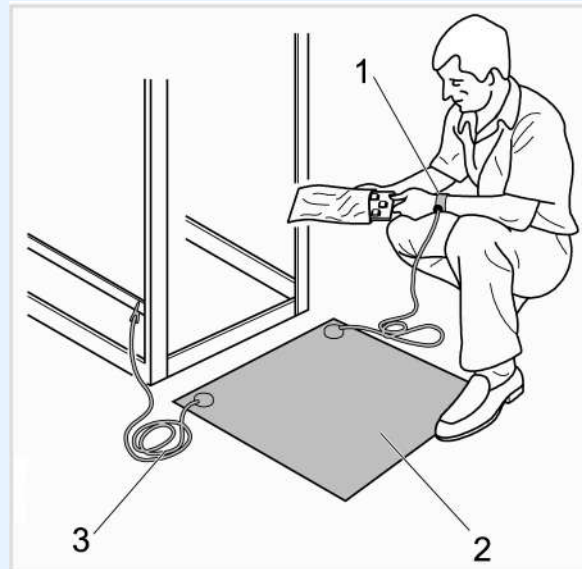

Fig: ESD protection kit

Safety Signs on the Product

- Do not remove or change safety signs!
- Replace illegible safety signs by genuine spare parts!
- Clean soiled safety signs!

Refer to the labelling drawings of the components to see the positions of the labels.



Disposal

- Dispose any material, batteries and X-ray equipment in accordance with the requirements of national legislation!
- Do not dispose X-ray equipment together with domestic waste!



- All Ralco's products conform to RoHS



- All Ralco's products conform to REACH

Safety Messages Reported Into The Manual



WARNING

This symbol combined with the signal word **WARNING** indicates a hazardous situation which, if not avoided, could result in death or serious injury.

If you do not obey these instructions, there is a risk of death or serious injury.



CAUTION

This symbol combined with the signal word **CAUTION** indicates a hazardous situation which, if not avoided, could result in minor or moderate injury.

If you do not obey these instructions, there is a risk of minor or moderate injury.

The shown symbols are sometimes replaced by other symbols which indicate the concrete risk:

Material Damage



NOTICE

This symbol combined with the signal word **NOTICE** indicates a hazardous situation which, if not avoided, could result in damages such as material damage. This damage is not related to personal injury.

If you do not obey these instructions, there is a risk of property damage.

Other Messages



Important

This symbol combined with the signal word **Important** indicates an important advice that points out that certain guidelines, parameters, conditions or restrictions must be observed.

For any inquires or notifications, please contact us at:

Ralco, srl
Via dei Tigli 13/G
20853 Biassono, (MB) Italia
Telephone: +39 039 2497925
Fax: +39 039 2497799
E-mail: ralco@ralco.it

DESCRIPTION

Multilayer, square field, manual collimation system intended for installation on stationary X-ray equipment. This device has been designed and manufactured for skeletal and thoracic investigations.

The X-ray field is defined by six pairs of shutters, four of which are lead-lined. The six pairs of shutters move perpendicularly within the X-ray field. Two pairs of brass shutters are located near the focus, two are located near the entrance window and two are located near the exit window of the X-ray beam from the collimator. The latter shutters serve to accurately define the X-ray field edges.

Shutter movements are manual, controlled by two knobs on the collimator front panel.

The Collimator is supplied with a plastic flange for collimator rotation; a device to limit rotation $\pm 90^\circ$ is optionally available.

CHARACTERISTICS

Mounting Plane at 80 mm (3.14") from the focus.

Continuous Film Coverage from Min: 00 x 00 cm to Max: 48 x 48 cm* at 100 cm (40") SID.

Maximum Radiation Leakage: 150 kVp - 4 mA.

Accessory Guides are used for accessories and additional filtration.

High luminosity provided by a **White LED** simulating the X-ray field. The light field is controlled by an electronic timer.

Minimum Inherent Filtration 2 mm aluminium equivalent.

Resin Rotating Mounting Flange allows the collimator to rotate, 20mm thickness, 0° detent, 140mm diameter.

GC-LED-4A timer board for light source supply and operation. The board is CanBus controlled.

*** If the collimator is assembled with the RO 452 the max aperture is 43 x 43 cm at 100 cm SID.**

Fig. R225 - R225 DHHS Front Panel and Exterior Dimensions

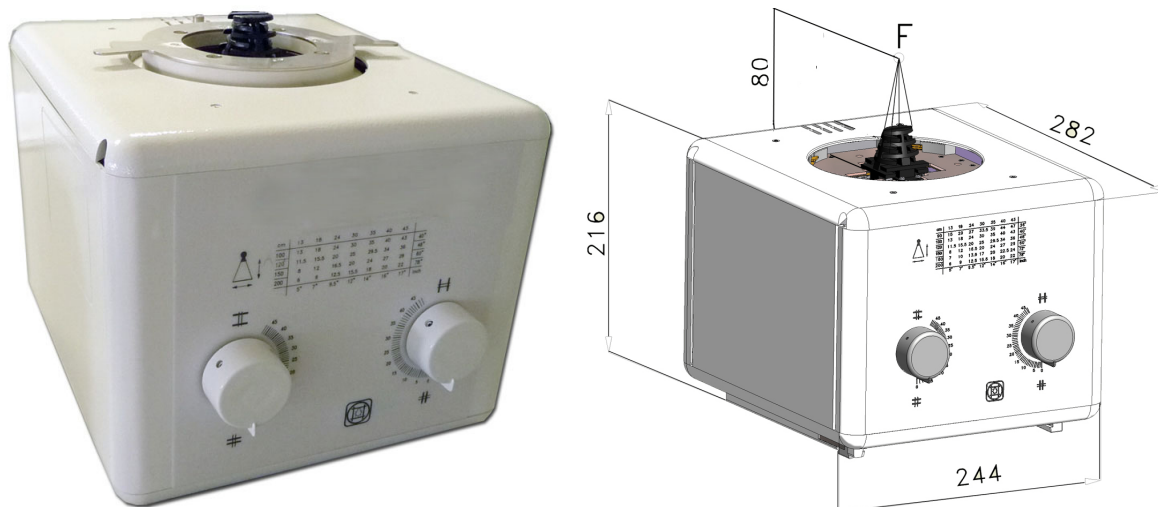

This collimator may have the following optional items; a detailed description is provided in the chapter **OPTIONAL ITEMS**.

RO	DESCRIPTION
RO 002	Iron mounting flange spacer: 1.5mm thickness
RO 012/B	Retractable measuring tape
RO 041	Mylar mirror with minimum internal inherent filtration: 0.3mm Al equivalent
RO 063	Final quality test report documentation (Light field, luminosity, light to X-ray field correspondence, light field border contrast ratio, x-ray leakage, control of general functions)
RO 074	External housing and guide rails in customized color
RO 077	Light centering device to align collimator with detector
RO 082	Glass mirror with minimum internal inherent filtration: 1mm Al equivalent
RO 096	Wiring customization
RO 107	Knob color customization
RO 111	Front panel customization
RO 203	Self-centering top-cover bracket for Siemens X-ray tube only (mounting flange provided by Siemens only)
RO 240	Focal-spot to skin spacer
RO 242/1	Single laser line to align collimator and detector center: Class 2
RO 242/2	Two lasers (one mounted externally) forming a crosshair to center the patient to the detector: Class 2
RO 258	Additional variable filtration - manual selection. 4 position rotating wheel with selectable filters (clockwise): (1) empty or (2) 0.1mm Cu+1mm Al or (3) 0.2mm Cu+1mm Al or (4) 2mm Al
RO 258/1	Additional variable filtration - manual selection. 4 position rotating wheel with selectable filters (clockwise): (1) empty or (2) 0.1mm Cu or (3) 0.2mm Cu or (4) 0.3mm Cu

R225 - R225 DHHS - Description

RO	DESCRIPTION
RO 332/A	Resin rotating mounting flange: 15mm thickness, +/-0° detent, 140mm diameter including fixing screws (not available with RO 492)
RO 344	Accessory guide rail spacers with support in RAL 9003 (Signal White)
RO 356	Shutter position verified by potentiometer: Output signal managed by customer
RO 369	Resin rotating mounting flange: 20mm thickness, +/-90° mechanical stop, 140mm diameter (not available with RO 492)
RO 370	Resin rotating mounting flange: 20mm thickness, +/-120° mechanical stop, 140mm diameter (not available with RO 492)
RO 409	Resin rotating mounting flange milled to form a square: 20mm thickness, +/-0° detent, 140mm diameter + three iron mounting flange spacers milled to form a square: 1.5mm thickness (not available with RO 492)
RO 441	Resin rotating mounting flange: 20mm thickness, +/-50° detent, 140mm diameter (not available with RO 492)
RO 442	Resin rotating mounting flange: 20mm thickness, +/-90° detent, 140mm diameter (not available with RO 492)
RO 445	Metal rotating mounting flange, 20mm thickness, +/-90° mechanical stop, 140mm diameter (not available with RO 492)
RO 452	Asymmetric longitudinal shutters (“stitching” application)
RO 456	Metal rotating mounting flange: 20mm thickness, +/-90° mechanical stop, 136mm diameter (only available with RO 492)
RO 489	Resin rotating mounting flange: 20mm thickness, +/-45° detent, 140mm diameter (not available with RO 492)
RO 492	Adjustable top-cover bracket for use with metal mounting flange (mounting flange not included)
RO 495	Camera assembled internally for patient monitoring: IP ethernet interface
RO 525	Knob customization
RO 530	Resin rotating mounting flange: 17mm thickness, +/-0° detent, 140mm diameter (not available with RO 492)
RO 586	Single laser line to align collimator and detector center: Class 1

R225 - R225 DHHS - Description

RO	DESCRIPTION
RO 587/2	Two lasers (one mounted externally) forming a crosshair to center the patient to the detector: Class 1

SPECIFICATIONS

NOTE



SPECIFICATIONS OF THE BASIC VERSION OF THE COLLIMATOR ARE DESCRIBED HERE BELOW.

POWER SUPPLY

Power Supply	24 V AC/DC - 2 A
Fuse for power supply protection collimator. Not supplied by Ralco.	T 3.15 A
Motor Supplied by Collimator Board	n.a.
Fuse for Power Supply Protection Motor. Not supplied by Ralco	n.a.
Potentiometers: Square Field Round Field	n.a. n.a.

RADIOLOGICAL SPECIFICATION

Inherent Filtration Al. Equivalent X-ray beam = 75 kV EN 60601-1-3 par. 7.3; 7.4	Min. Al Eq. 2 mm
Filtration, Additional X-ray beam = 75 kV EN 60601-1-3 par. 7.5	n.a.
Limitation of Extra Focal Radiation Set Focus Distance, SID 100 cm (40") EN 60601-2-54	< 150 mm
Square X-ray Field Selection 100 cm (40") SID - (\pm 1% SID) EN 60601-2-54	Min: 00 x 00 cm Max: 48 x 48 cm*

R225 - R225 DHHS - Specifications



RADIOLOGICAL SPECIFICATION

Round X-ray Field Selection 1 m SID - (\pm 1% SID) EN 60601-2-54	n.a.
Light Field Indicator Luminosity at 1 m from the focus, field size set at 35x35 cm. EN 60601-2-54	> 160 lux
Light Field Indicator - Contrast Edge Contrast Setting 35x35 cm at 1 m SID EN 60601-2-54	> 4:1
Light Field Indicator Precision Light Field/X-ray Field Correspondence EN 60601-2-54	< 1 % SID>
Accuracy of X-ray field as shown on the front display versus actual X-ray field dimension.	n.a.
X-ray Field Indication Precision Settings on an Index Scale EN 60601-2-54	< 2 % SID
SID: (optional) Precision of Measurement with Retractable Tape EN 60601-2-54	< 2% SID
Maximum Radiation Leakage Measured at 100 cm with X-ray Beam = 150 kVp - 4 mA EN 60601-1-3	< 40 mRh

GENERAL SPECIFICATIONS

Operation Environment Ambient Temperature Relative Humidity Atmospheric Pressure	10° - 40°C 10% - 75% 700 - 1060 hPa
Storage Temperature Humidity Atmospheric Pressure	-40° - +70°C 10% - 95% 500 - 1060 hPa
Weight* * The weight may vary according to the optional items mounted to the collimator.	9.8 Kg

GENERAL SPECIFICATIONS

Dimensions	L: 282 mm W: 244 mm H: 216 mm
Maximum Load for Accessory Rails and Dimensions for Accessory	Static load: 70 N (about 7.1 Kg) Dynamic load: 15 Nm (approx. 3.06 Kg)
Distance between Rail Slots	177 mm (+/- 0.5 mm)**

**



ATTENTION:

THE DISTANCE BETWEEN TWO RAILS VARIES AND DEPENDS ON THE COLLIMATOR MODEL. PRIOR TO INSERTING ACCESSORIES IN THE RAILS MAKE SURE THAT THE DIMENSIONS OF THE ACCESSORY MATCHES WITH THE DISTANCE BETWEEN TWO RAILS SLOTS (TOLERANCE MAX. $\pm 0,5$ MM). THE INCORRECT DIMENSION CAN LEAD TO DANGEROUS SITUATIONS AND/OR TO THE ACCESSORY FALLING. SEE THE CHAPTER **OPTIONAL ITEMS** IF THE RAILS DIFFER FROM THE STANDARD ONES.

*** If the collimator is assembled with the RO 452 the max aperture is 43 x 43 cm at 100 cm SID.**

INSTALLATION

TUBE COMPATIBILITY

WARNINGS



THE COLLIMATOR MUST BE INSTALLED TO THE X-RAY TUBE THROUGH A MOUNTING FLANGE. RALCO PROVIDES VARIOUS FLANGE OPTIONS WHICH MAY NOT BE INTERCHANGEABLE. ONLY FLANGES PROVIDED WITH THE COLLIMATOR MAY BE UTILIZED. THE END-USER MAY INSTALL THEIR OWN FLANGE, HOWEVER RALCO CANNOT GUARANTEE COMPATIBILITY. ANY PREEXISTING FLANGE ON THE END-USER SYSTEM MUST NOT BE USED.



WHEN A FLANGE IS PROVIDED WITH THE COLLIMATOR BEARING A MATCHING SERIAL NUMBER, ENSURE THEY ALWAYS REMAIN COUPLED. IT IS MANDATORY THEY REMAIN TOGETHER AND THE CORRECT FLANGE PART NUMBER IS USED.



THE CONTENTS OF THE INSTRUCTIONS BELOW SHOULD BE STRICTLY ADHERED TO. RALCO IS NOT LIABLE FOR ANY PROPERTY DAMAGE OR RESULTING HARM IF NON-RALCO COMPONENTS OR NON-COMPATIBLE RALCO COMPONENTS ARE USED DURING THE INSTALLATION PROCESS.

- Using the dimensions in **Fig. Tube Compatibility** below, ensure the near port shutters of the collimator are placed in the X-Ray tube port without interference.
 - Assembly values (X-Ray tube housing and collimator) must comply with a minimum value of inherent filtration and a maximum value of radiation leakage.
- The distance between the X-Ray tube focus and the flange mounting plane (collimator upper plate) must be: 80 mm (3.14"), tolerance +/- 1 mm (0.04 ").

Fig. Tube Compatibility

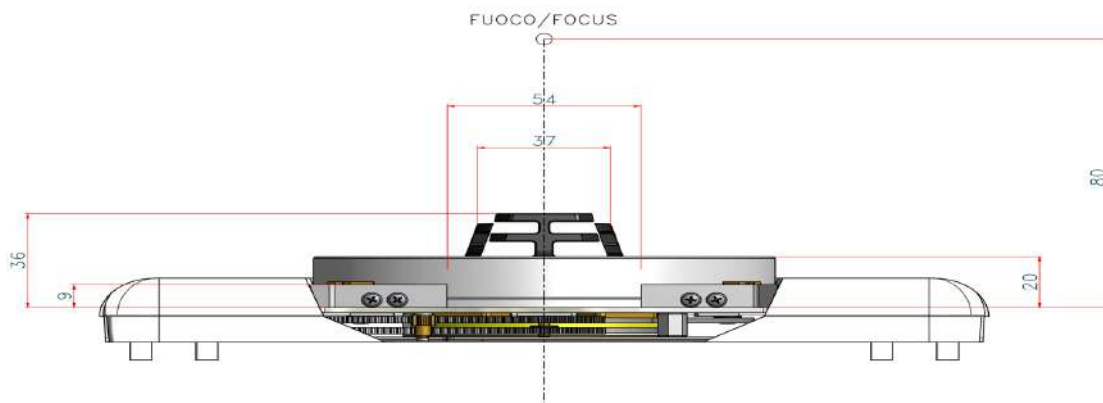

3. Carefully remove the collimator and the mounting flange from their packaging.
4. Use the X-Ray tube housing datasheet to determine the distance (A) from the focal spot to the X-Ray tube port, see **Fig. Collimator Installation**.
5. Subtract the resulting distance from the source flange distance (B) and determine the number of spacers (1.5 mm) which, combined with the thickness of the mounting flange, will make up the difference (C). Allowable tolerance is 1 mm. (0.04"), see **Fig. Collimator Installation**.
6. Once the mounting plane distance has been confirmed, continue with the mounting flange installation to the X-Ray tube.

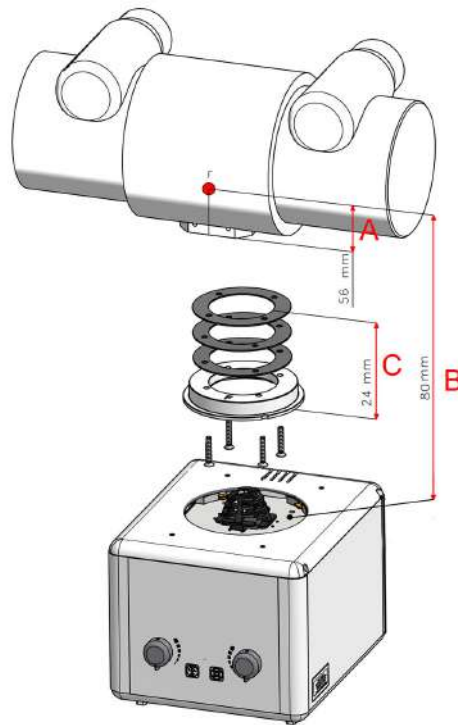

Fig. Collimator Installation

The flange fixing screws and the spacers of the previous flange may be reused if the flange thickness is the same.

MOUNTING THE FLANGE TO THE X-RAY TUBE

NOTE



THE FOLLOWING MOUNTING INSTRUCTIONS ARE ONLY APPLICABLE FOR COMPATIBLE FLANGES. IF YOU ARE UNSURE THE MOUNTING FLANGE YOUR COLLIMATOR IS EQUIPPED WITH IS COMPATIBLE, PLEASE CONSULT YOUR PERSONALIZATION PAGE PROVIDED WITH THIS MANUAL TO LOCATE THE FLANGE PART NUMBER (RO REFERENCE). FOLLOW THE MOUNTING INSTRUCTIONS SET FORTH UNDER THE SPECIFIC RO REFERENCE IN THIS MANUAL.

WARNING



FLANGES MAY BE PROVIDED BY RALCO OR BY THE SYSTEM MANUFACTURER. FLANGES MAY NOT BE INTERCHANGEABLE. ONLY THE FLANGE PROVIDED WITH THE COLLIMATOR BEING INSTALLED WITH A SPECIFIC PART CODE MAY BE UTILIZED. ANY PRE-EXISTING FLANGES MAY NOT TO BE USED. IF THERE ARE ANY QUESTIONS REGARDING COMPATIBILITY, PLEASE CONTACT RALCO.

CAUTION



RALCO CANNOT GUARANTEE COMPLIANCE WITH RADIATION STANDARDS CONCERNING SAFETY IF THIS CONTROL HAS BEEN OMITTED.

1. Place the flange on the X-Ray tube port, see **Fig. Flange Installation**.
2. Mount the mounting flange and spacers (optional) to the X-Ray tube port using 4 screws.**

***Please ensure no conflicting information nor dangerous conditions exist due to adhering to these instructions or those provided by the X-Ray tube manufacturer. When in doubt please contact X-ray tube manufacturer and/or Ralco.*

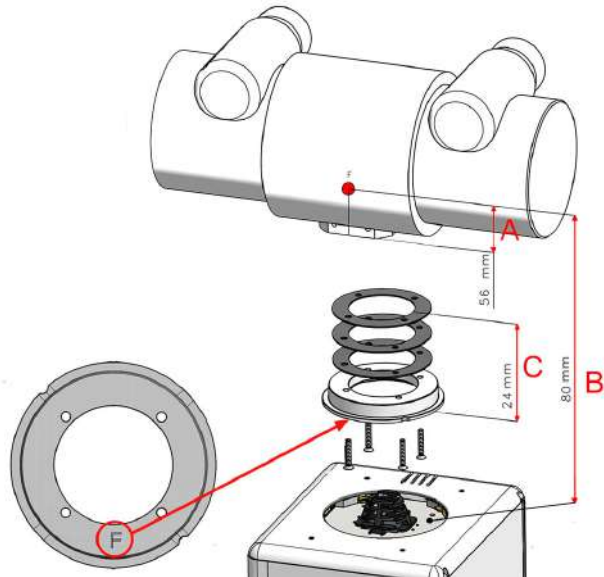

Fig. Flange Installation

*illustrative purpose only

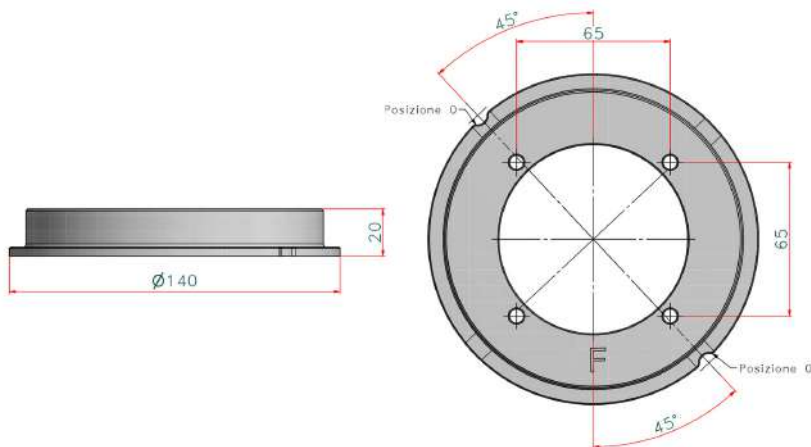

Fig. Mounting Flange

CAUTION



THE FLANGE MUST BE PLACED WITH THE LETTER "F" FACING TOWARD THE X-RAY TUBE PORT. INCORRECT POSITION MAY CAUSE THE COLLIMATOR AND FLANGE TO MALFUNCTION.



ENSURE THE SCREW HEAD IS INDEED CORRECT FOR THE FLANGE SELECTED. IT IS THE RESPONSIBILITY OF THE END-USER TO ENSURE ALL SAFETY MEASURES ARE IMPLEMENTED TO ENSURE THE SCREWS ARE OPTIMALLY TIGHTENED INCLUDING THE USE OF APPROPRIATE LOCKTITE.



TIGHTEN THE 4 SCREWS TO THE X-RAY TUBE HEAD SECURELY, STRICTLY ACCORDING TO THE INSTRUCTIONS OF THE X-RAY TUBE MANUFACTURER. DO NOT EXCEED 0.45 NM OF FORCE.

ALIGNMENT OF X-RAY TUBE FOCUS AND COLLIMATOR

Ralco guarantees the correct collimator functionality, format compliance and light/X-Ray field alignment only if the mounting flange and the collimator have been installed exactly in the centre of the X-Ray beam.

All Ralco collimators are aligned on our test bench utilizing specific references/values for our X-Ray tube focus, detector and Source to Image Detector Distance (SID). The customer must know and verify all known variables which may influence the X-Ray tube focus and collimator alignment. These may include, the X-Ray tube focus position tolerance, distance from X-Ray tube focus to collimator mounting plane, or the SID.

Alignment Device

This device is used to ensure the collimator mounting flange is correctly aligned to the X-ray beam. The X-ray tube manufacturer provides a tolerance for the placement of X-ray tube focus.

Ralco recommends to use the Focal Alignment Device (jig) to ensure the correct flange alignment with the centre of the X-Ray beam, see **Fig. Focal Alignment Device**. By making an exposure, it is possible to verify the perpendicularity and concentricity using fixed references on the X-Ray image.

Once the mounting flange is aligned the collimator light/X-ray field should also be aligned (within specific tolerances).

Please consult the technical specifications of your X-Ray tube to find the maximum tolerance for the

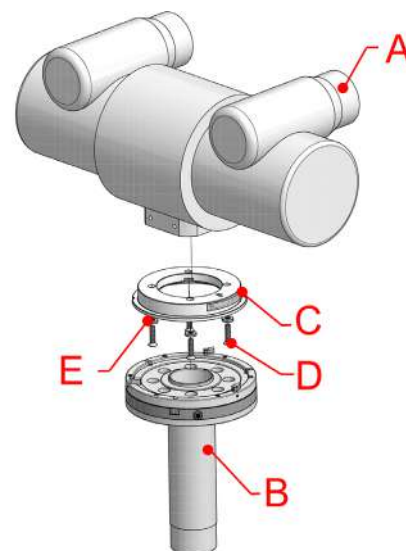

A - X-Ray Tube, B - Focal Adjustment Device
C - Mounting Flange, D - Screw, E - Washer

Fig. Focal Alignment Device

R225 - R225 DHHS - Installation

position of the focus. Should the use of an alignment device not be possible, Ralco collimators allow for the regulation of the light field.

Mounting the Collimator to the Flange

NOTE



THE MOUNTING FLANGE PROVIDED (IF PURCHASED) WITH THE COLLIMATOR IS SUBJECTED TO TESTING PURSUANT TO ALL APPLICABLE STANDARDS.



MOUNTING BRACKET TABS CONFORM TO EN60601.

WARNINGS



PURSUANT TO APPLICABLE STANDARDS, RALCO HAS TESTED THE COLLIMATOR AND FLANGE APPLYING STATIC LOADS. RALCO IS NOT IN A POSITION TO KNOW THE DYNAMIC FORCES OF ALL END-USER SYSTEMS. IT IS THE RESPONSIBILITY OF THE END-USER TO ENSURE DYNAMIC FORCES OF THE SYSTEM DO NOT CREATE A DANGEROUS CONDITION.



IT IS THE RESPONSIBILITY OF THE SYSTEM MANUFACTURER TO ENSURE AND MITIGATE ANY DANGEROUS CONDITIONS WHICH MAY OCCUR DUE TO THE DYNAMIC FORCES CREATED BY THE SYSTEM. THE END-USER MUST PERFORM A SYSTEMATIC AND STRUCTURAL ANALYSIS DURING THE INSTALLATION AND USUAL MAINTENANCE.



SHOULD ANY DAMAGE TO THE COLLIMATOR OR FLANGE OCCUR A RISK ANALYSIS AND DAMAGE ASSESSMENT NEEDS TO BE CONDUCTED IMMEDIATELY. CONTACT RALCO IMMEDIATELY SHOULD THIS OCCUR. RALCO IS NOT LIABLE FOR RESULTING PROPERTY DAMAGE AND/OR HARM DUE TO AN UNREPORTED INCIDENT.



RALCO HAS DESIGNED AND TESTED THE COLLIMATOR FOR A LIFETIME OF 10 YEARS. AFTER THIS TIME PERIOD, IT IS THE RESPONSIBILITY OF THE END-USER TO ENSURE THE PROPER FUNCTIONING OF THE COLLIMATOR AND FLANGE. LIABILITY FOR ANY DANGEROUS CONDITIONS WHICH MAY BE PRESENT AFTER THE 10YEAR LIFETIME OF THE COLLIMATOR AND FLANGE RESTS WITH THE END-USER.



TO ENSURE THE SAFETY OF THE COLLIMATOR AND FLANGE AFTER 10 YEARS OF USE, RALCO HAS INSTITUTED A PROGRAM TO ASSESS THE SAFETY OF THE COLLIMATOR AND FLANGE. AFTER APPLYING A CHECK LIST OF QUALITY CONTROLS AND REFURBISHMENT ACTIVITIES (AT END-USER EXPENSE), RALCO MAY CERTIFY THE COLLIMATOR AND FLANGE FOR ADDITIONAL YEARS OF USE.

The mounting bracket has 2 tabs with springs in positions 2 and 4, while the 2 tabs in position 1 and 3 cover the surface of the outer ring of the flange, see **Fig. Mounting Bracket**.

1. Prepare the collimator to be installed by unscrewing the 4 hexagonal socket screws until the four tabs are completely withdrawn from the collimator top mounting plane, see **Fig. 4 Mounting Screws**.
2. If installing a manual collimator, adjust the collimator shutters to the fully open position using both knobs.

CAUTION



WHEN UNSCREWING THE HEXAGONAL SOCKET SCREW WHICH CONTROL THE TABS, DO NOT USE FORCE EXCEEDING 0,45 NM. UNSCREW WITH CARE SO AS NOT TO DAMAGE THE HEXAGONAL SCREW HEAD AND TABS.

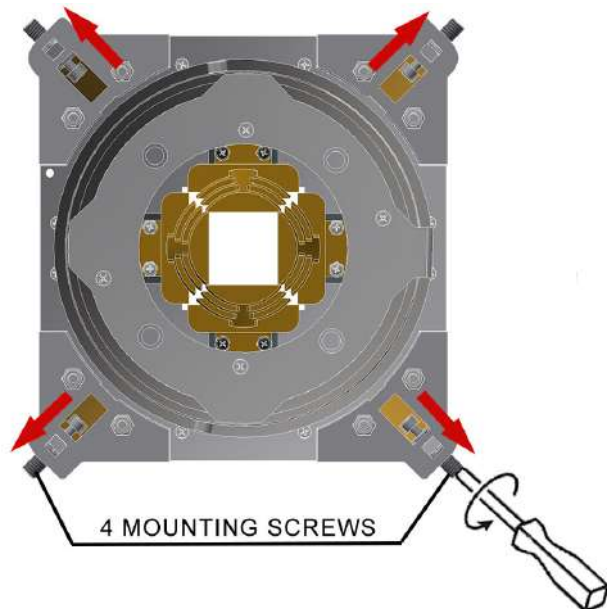

Fig. Collimator Mounting Bracket

3. With the tabs fully retracted, tabs in position 1 and 3 which overlap the outer ring must be tightening equally up to the end stroke with 0.45 Nm torque (at least 7 turns). See **Fig. Mounting Bracket**.
4. With the tabs fully retracted, the tabs in position 2 and 4 have an integrated adjustable spring and can be tightened in two different ways allowing the flange to be fixed or to rotate, see **Fig. Mounting Bracket**.

FIXED (NO ROTATION)

With the tabs fully retracted, tighten all tabs up to the end stroke with 0.45Nm torque at least 7 turns (if you are not able to respect the turns something is incorrect, repeat above instructions, if issues persist, please contact Ralco).

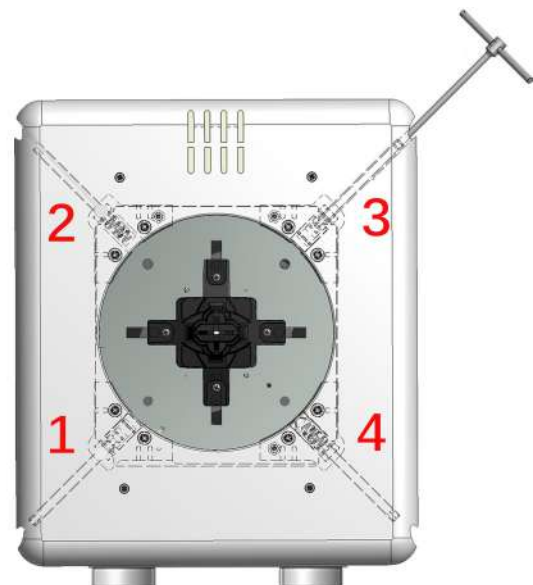

Fig. Mounting Bracket

**illustrative purpose only*

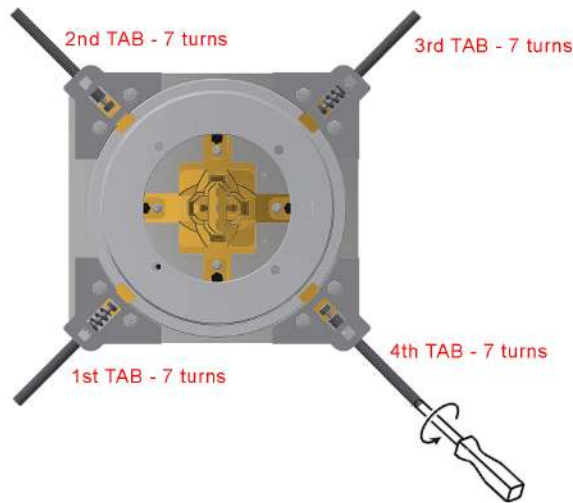

Fig. Mounting Bracket (Fixed)

WITH ROTATION

With the tabs fully retracted, tighten tabs in the following sequence (if you are not able to respect the turns something is incorrect, repeat above instructions, if issues persist, please contact Ralco):

- Tabs 1 and 3 - minimum of 7 turns
- Tabs 2 and 4 – exactly 5 ½ turns.

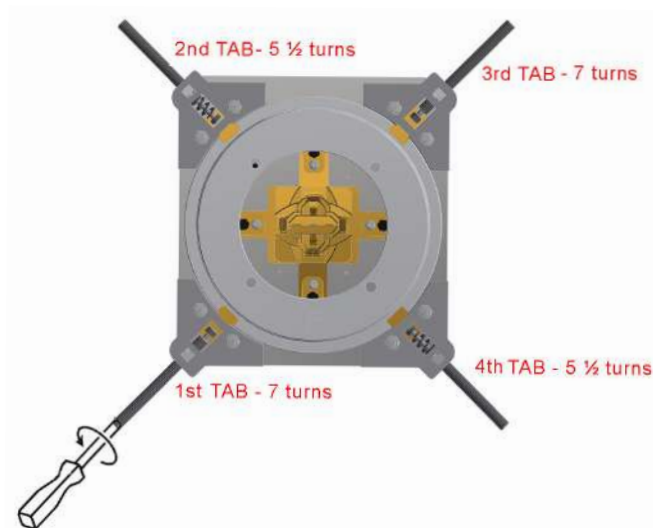

Fig. Mounting Bracket (Rotating)

The collimator tabs glide on the flange outer ring and the collimator rotates towards the X- Ray tube axis. If, however:

- The release force from the position 0° and the collimator rotation is too low, the two tabs of the tab 2 and 4 need to be tighten ½ turn.
- The release force from the position 0° and the collimator rotation is too high, the two tabs of the tab 2 and 4 need to be loosened ½ turn.

VERIFICATION OF CORRECT INSTALLATION

WARNING



IT IS THE DUTY OF THE INSTALLER TO ENSURE NO RISK OF THE COLLIMATOR FALLING EXISTS. ENS URE THE FOLLOWING, AS IN EACH SCENARIO BELOW SERIOUS RISK OF INJURY AND/OR PROPERTY DAMAGE MAY EXIST DUE TO NON-ADHERENCE.

1. The 4 tabs should overlap the flange outer ring, see **Fig. Correct Overlap**.
2. Ensure the mounting flange is flat against the collimator mounting plane, see **Fig. Correct Overlap**.
3. Ensure the 4 tabs are not in contact with only the mounting flange edge, see **Fig. Incorrect Overlap**.
4. Once the collimator is mounted, if not already, return the collimator/tube head to the intended use position. Rotate and/or gently pull the collimator to ensure correct coupling.
5. If the collimator is loose, something is incorrect. Repeat above mounting instructions, and if issues persist, please contact Ralco.

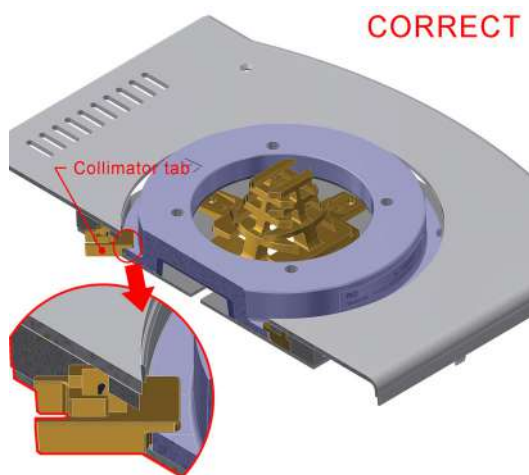

Fig. Correct Overlap



Fig. Incorrect Overlap

ELECTRICAL CONNECTION

NOTE



THE WIRING DIAGRAM INCLUDED IN THIS DOCUMENT REFERS TO THE STANDARD PRODUCT. IT IS THE RESPONSIBILITY OF THE CUSTOMER WHO HAS REQUESTED AN ELECTRIC CUSTOMIZATION, TO ENSURE THAT AN ELECTRIC DIAGRAM RELATING TO THE CUSTOMIZATION HAS BEEN PROVIDED WITH THE DOCUMENTATION.



THE DEVICE IS PROJECTED TO OPERATE WITH A PERMANENT POWER SUPPLY PRESENT SO THE PROCEDURE OF SWITCHING OFF THE COLLIMATOR IS NOT FORESEEN. NO RISK OR DEVICE DAMAGE WILL OCCUR IF THE MACHINE IS ACCIDENTLY SWITCHED OFF.

WARNING



THE DEVICE MUST BE EXCLUSIVELY CONNECTED TO POWER NETWORK, WITH EARTH PROTECTION, IN ORDER TO AVOID A RISK OF ELECTRICAL SHOCK.



SUPPLY AND SIGNALS TO THE COLLIMATOR MUST BE TO 2007/47/CE STANDARDS. DEVICES THAT SUPPLY THE COLLIMATOR MUST THEREFORE FEATURE DOUBLE OR REINFORCED INSULATION AS PROVIDED BY THE GENERAL STANDARD ON ELECTROMEDICAL EQUIPMENT CEI62-5 +A2 (EN 60601-1). THE DEVICE IS ELECTROSTATIC SENSITIVE, CONSEQUENTLY ALL THE RELATING SAFETY STANDARDS MUST BE COMPLIED WITH.



COLLIMATOR MUST BE SUPPLIED AS SPECIFIED, SEE CHAPTER **SPECIFICATIONS**. THE SUPPLY MUST COME FROM A SEPARATE SOURCE FROM THE POWER NETWORK THROUGH DOUBLE INSULATION OR REINFORCED INSULATION AND WITH LIMITED CURRENT. TRANSFORMER CHARACTERISTICS MUST CONFORM TO THE REQUIREMENTS OF STANDARD IEC 60601-1.



CABLES AND TERMINALS USED FOR THE INTERNAL CONNECTION OF THE COLLIMATOR MUST BE SUITABLE FOR OPERATION AT TEMPERATURES OF 80°C AND COLLIMATOR CURRENT ABSORPTION.



TO ENSURE THE SAFE USE OF THE COLLIMATOR, IT IS MANDATORY TO SECURELY AND FIRMLY INSERT THE POWER SUPPLY/DATA CABLE BETWEEN THE COLLIMATOR AND RADIOLOGICAL SYSTEM. IT IS ALSO MANDATORY THAT THE POWER SUPPLY/DATA CABLE IS CORRECTLY SECURED TO THE STRAIN RELIEF. IF THE STRAIN RELIEF IS MISSING IT IS MANDATORY ONE BE CORRECTLY AND SECURELY INSTALLED. RALCO IS NOT LIABLE FOR DAMAGES IN THE EVENT OF MISSING OR INCORRECT CABLE INSTALLATION.

Power Supply Connection

- Remove the part of cover to access the terminal, see Chapter- **COVER REMOVAL**.

R225 - R225 DHHS - Installation

- Connect supply cables to the relative collimator terminals and earth on the screw marked with the relating symbol:  . Use the protective earth cable with green/yellow insulation.
- In collimators with a free cable stop, remove the cable stop, connect the supply cables, remount and then secure the cable stop.
- Remount the cover.

WARNINGS



INCORRECT POWER SUPPLY COULD DAMAGE THE ELECTRONIC BOARDS AND/OR THE LIGHT SOURCE.
SUPPLY MAY BE EITHER IN ALTERNATE OR DIRECT CURRENT.
MAKE CERTAIN THAT POLARITY IS RESPECTED.

Wiring Diagram

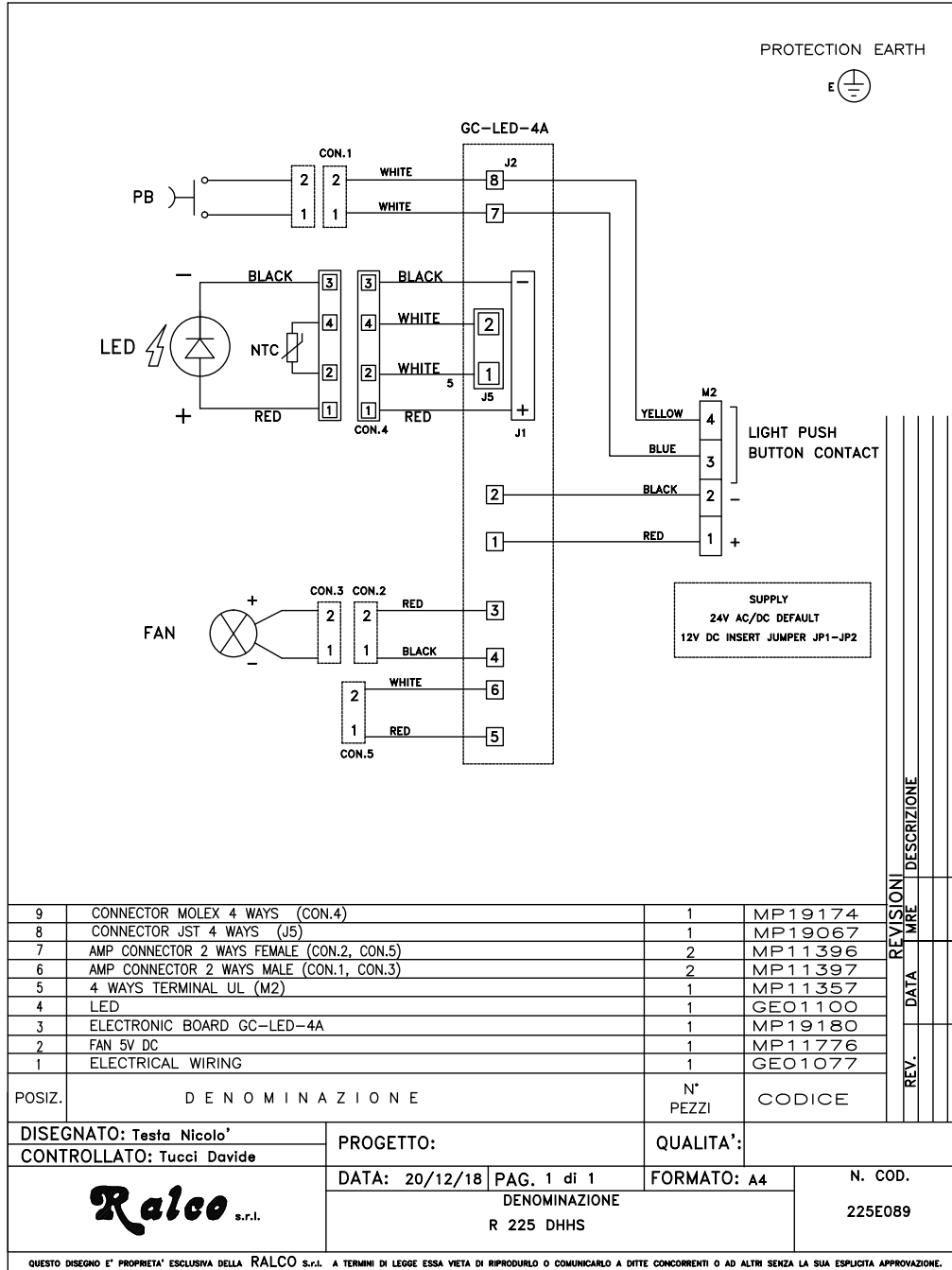

R225 - R225 DHHS - Installation

GC-LED-4A

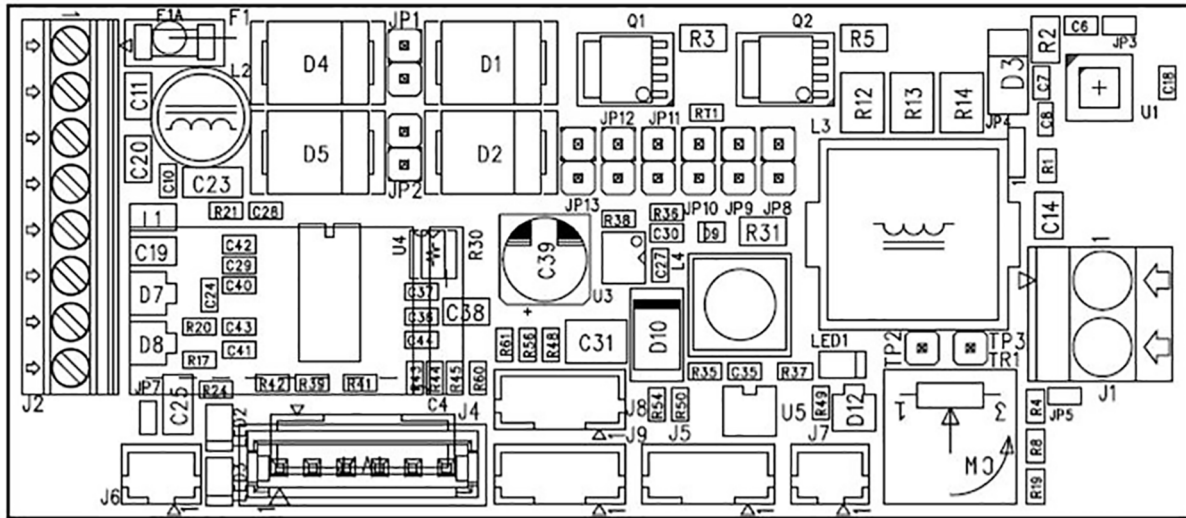

Fig. Timer Board Layout

CONNECTORS

<p>J2 - SUPPLY AND OUTPUTS</p>	<ol style="list-style-type: none"> 1. 24 V AC/DC or 12 V DC 2. 24 V AC/DC or 12 V DC 3. +5 V Fan 4. GND Fan 5. +5 V Laser 6. GND Laser 7. + external light push-button 8. GND external light push-button
<p>J1 - LED OUTPUT</p>	<ol style="list-style-type: none"> 1. + LED 5 A positive output 2. - GND Led 5A
<p>J3 - PROGRAMMING CONNECTORS</p>	<ol style="list-style-type: none"> 1. Vpp 2. +5 V 3. GND 4. PGD 5. PGC 6. NC
<p>J4 - HOME SENSOR INPUT + EXTERNAL LED</p>	<ol style="list-style-type: none"> 1. + External LED 2. - External LED 3. - Photosensor LED Cathode 4. + Photosensor LED Anode 5. Input signal (Photosensor output collector) 6. GND (Photosensor output emitter)
<p>J5 - PUSH BUTTON INPUT + NTC EXTERNAL LED</p>	<ol style="list-style-type: none"> 1. NTC LED input 2. NTC LED input 3. Laser input, pin 1 4. Laser input, pin 2

R225 - R225 DHHS - Installation

J6 - OPEN-COLLECTOR OUTPUT	<ol style="list-style-type: none"> 1. +5 V 1. GND
J7 - OPEN-COLLECTOR (ABNORMAL OPERATION MANAGEMENT)	<ol style="list-style-type: none"> 1. + 2. -
J8 - J9 - ENCODER (By connecting an opto-switch it is possible to switch ON the light when the shutter move) **The encoder reading is available for s.w. 2.00 and 5.00	<ol style="list-style-type: none"> 1. +LED 2. IN 3. GND 4. GND
Jumpers	OFF: without jumper ON: with jumper
JP1, JP2 - ALTERNATE/DIRECT POWER SUPPLY	OFF: alternate power supply ON: direct power supply (pay attention to polarity)
JP5 - LED POWER SUPPLY UP TO 6.2 A (STANDARD SETTING 4 A)	OFF: LED power supply is adjustable through trimmer to max. 4.8 A ON: LED power supply is adjustable through trimmer to max. 6.2 A
JP14 - ADDITIONAL RESISTANCE	OFF: standard input ON: used to power a retro-reflective photocell
JP8, JP9, JP10, JP11, JP12, JP13 - Operation mode selection	
JP8 - TIME RENEW MODE	OFF: Standard ON: the timer operates in the time renew mode. When the button is pressed the time is renewed without the LED OFF (if the LED is already ON, continues to stay ON but with renewed time). The same is applicable for the laser if is independent.
JP9 - LASER CONTROLLED INDEPENDENTLY	OFF: Standard ON: When the button, placed on J5, is pressed the laser switches ON independently from the light.
JP11, JP10* - TIME MANAGEMENT	OFF, OFF: 30 seconds ON, OFF: 45 seconds OFF, ON: 60 seconds ON, ON: power supply (maximum light ON time is 15 min. for safety reasons). JP10 - LED auto shutdown exclusion, available in s.w. 4.00 only

<p>JP12, JP13 - SOFTWARE CONFIGURATION</p>	<p>OFF, OFF: s.w.2.00 (standard) - it is possible to use the encoder management to switch ON/OFF the laser and LED ON, OFF: s.w.3.01 - power supply without any safety and shutdown time. OFF, ON: s.w.5.00 with the LED off, pressing the button only turns on the LED and the fan. If the button is pressed again within 5 seconds, the laser also lights up. Pushing the button after the first 5 seconds, everything will switch off The LED and eventually the laser switch off anyway when the time set with the trimmer has set (in this mode it is possible to use the encoder management to switch on light / laser).</p> <p>ON, ON: s.w.4.00 (following the button, the switching on of the board is controlled by closing the contact) If the board is configured as JP8 standard: OFF:(pushing the button the status will change) (if on will switch off and the other way around) ON: The board works in renewal time mode. In this mode, each time the button is pressed, the ignition time is renewed without switching off the light. If the light is already on, it continues to stay on but with renewed time. Also applies to the laser if independent</p>
<p>FAN</p>	<p>The fan switches ON together with the LED, and operates 15 seconds longer after the LED OFF.</p>
<p>Trimmers</p>	
<p>TR1- CURRENT CONTROL</p>	<p>Adjust the output current intensity to the LED. Step-less current adjustment from 0 to 4.8 A. -> Luxeon V LED - adjust current to ~ 2.2 A.</p>
<p>LEDs</p>	
<p>GREEN LED 1</p>	<p>Power supply + 5 V</p>
<p>YELLOW LED 2</p>	<p>Indicates software version: 1 blink = standard sw 2 blinks = 3.01 sw 3 blinks = 5.00 sw 4 blinks = 4.00 LED 2 will stop blinking if LED 3 is ON.</p>
<p>LED 3 - ALARMS</p>	<p>Indicates an alarm type Switch OFF - OK 1 blink = LED disconnected or faulty driver 2 blinks = LED short-circuited 3 blinks = Fan failure or disconnected 4 blinks = Laser failure or disconnected 5 blinks = Push button pressed longer than 5 seconds or short-circuited 6 blinks = Timer temperature >105° 7 blinks = LED temperature >110°</p>
<p>ALARM DIAGNOSTIC</p>	

R225 - R225 DHHS - Installation

The timer identifies anomalies/errors/malfunctions. The outgoing messages from J7 are managed and interpreted by “intelligent board”

bit = 10 ms

byte:

1 bit sync (1)

8 bit data - transmission bit L....H

1 bit stop (0)

Output status:

0 = output disabled

1 = output enabled

BYTE 1: firmware version

BYTE 2: firmware mode + jumper status

bit7: firmware mode bit 1

bit6: firmware mode bit 0

bit5: JP13

bit4: JP12

bit3: JP11

bit2: JP10

bit1: JP9

bit0: JP8

BYTE 3: input/output status

bit7: 1 = LED push button pressed

bit6: 1 = Laser push button pressed

bit5: 1 = ENC1 input activated

bit4: 1 = ENC2 input activated

bit3: 1 = O.C. output activated

bit2: 1 = Laser ON

bit1: 1 = Fan ON

bit0: 1 = LED ON

BYTE 4: alarms:

bit7:

bit6: High LED temperature

bit5: High timer temperature

bit4: Push button pressed more than 5 seconds

bit3: Laser error

bit2: Fan error

bit1: LED short-circuited

bit0: LED disconnected or faulty driver

OPERATION INSTRUCTIONS

LIGHT/X-RAY FIELD SETTING

- Set the collimator at 100 cm SID.
- By rotating the knobs and with the knob index on the front panel, follow the tags of the scale.
- Do not force the knobs.
- Activate the light field by pressing the related push-button on the collimator front panel.
- The collimator is ready to operate.

WARNINGS



PROLONGED LIGHTING WITHOUT ALLOWING LIGHT SOURCE TO COOL CAUSES THE COLLIMATOR TO OVERHEAT IN THE AREA NEAR THE LIGHT SOURCE. FOR EMERGENCIES: MAXIMUM LIMIT ADVISED IS 5 SUCCESSIVE LIGHT SOURCE OPERATIONS. ALLOW THE COLLIMATOR TO COOL (ABOUT 10 MIN).

CAUTION



BY INCREASING THE CONSECUTIVE "ON" TIMES, THE SUBSEQUENT REST PERIODS NEED TO BE EXTENDED ACCORDINGLY. IT IS IMPRUDENT TO PERFORM TWO CONSECUTIVE CYCLES OF 5 **ON** TIMES.

The collimator has been designed to operate as follows:

- Supply constantly connected during operation of the equipment.
- Light source ON time for the light field is factory set at 30 seconds (tol.20%). It is adjustable from 30 to 45 seconds via a trimmer on the timer board.
- The normal ON/OFF cycle is set at 1 minute followed by an idle time of 4 minutes to allow for cooling time (i.e. 1 minute ON/ 4 minutes OFF).
- The field is set by the two knobs on the front panel by following the indications of the scale with the knob index or visually with the light field.

Front Panel

The X-ray field is set through the knobs that control the shutter movement. The table provides the readout of the values which must be set with the knobs. The exact value to be set is obtained by crossing the SID in use (the value indicated by vertical axis), with the cassette size value in cm or inches (horizontal axis).

E.g.

To obtain the X-ray field **24 cm (LONG) x 35 cm (CROSS)** at SID 150 cm, with reference to the chart, set the Long knob indicator to **16.5 cm** and the Cross knob indicator to **24 cm**. See **Fig. Long Aperture** and **Fig. Cross Aperture**.

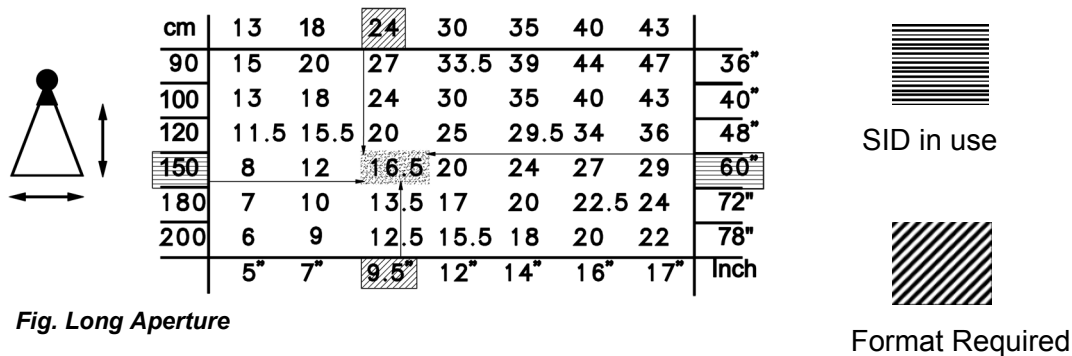

Fig. Long Aperture

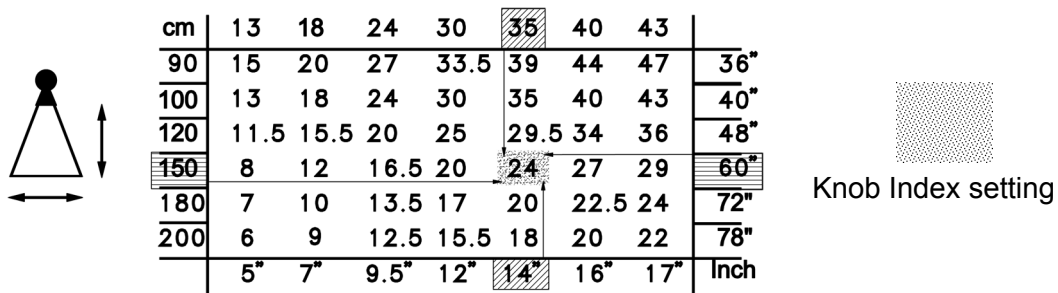
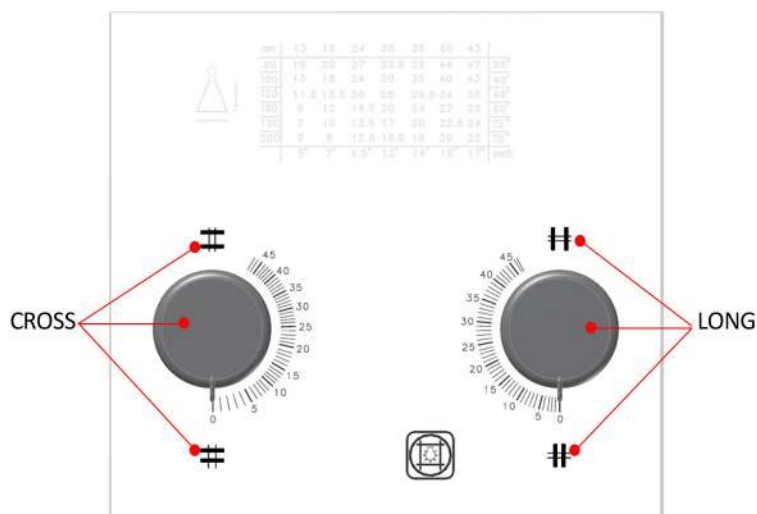

Fig. Cross Aperture



CALIBRATION

WARNINGS



THE FOLLOWING PROCEDURES REQUIRE THAT X-RADIATION BE PRODUCED. TAKE ADEQUATE PRECAUTIONS TO MAKE CERTAIN THAT NO PART OF THE HUMAN BODY IS EXPOSED TO X-RADIATION, DIRECT OR INDIRECT.

CENTERING X-RAY BEAM WITH COLLIMATOR LIGHT

- Select large focus, 60 kV and 5 mAs or equivalent for digital receptor.
- Place a loaded cassette 24 x 30 cm (9.5"x 12") on the table top and prepare exposure.
- Set SID = 100 cm (40") by using a ruler.

NOTE



IF THE DISTANCE OF 100 CM (40") SID CANNOT BE DETERMINED, USE THE SID VALUE CLOSEST TO 100 CM (40") AND CALCULATE THE MEASUREMENT TOLERANCES AS THE APPROPRIATE PERCENTAGES OF THE DISTANCE.



IF THE X-RAY BEAM CANNOT BE POSITIONED VERTICALLY USE CLAMPS, MASKING TAPE, OR OTHER MATERIAL AS REQUIRED TO POSITION THE X-RAY TUBE AND IMAGE RECEPTOR. THE X-RAY TUBE AND THE IMAGE RECEPTOR MUST BE SET OUT AT THE SPECIFIED SID DISTANCE PERPENDICULARLY TO THE X-RAY TUBE AS DESCRIBED IN THE FOLLOWING PROCEDURE.

NOTE



FIGURE CHECK LIGHT FIELD/X-RAY FIELD SHOWS AN EXAMPLE WITH FILM CASSETTE. THE SAME PRINCIPLE CAN BE USED FOR A DIGITAL SYSTEM.

- Set field to 24 x 30 cm.
- Centre the X-ray tube on the cassette.
- Switch ON the light and place four metal strips (c) on the light field edges (a).
- Place a washer (d) on the right hand-top of the light field.
- Make an exposure.
- Develop the film or print exposure scale 1:1.
- Measure the differences L1, L2 W1 and W2 between the outer edge of each copper strips image and the corresponding edge of the X-ray Field (b).
- For required values is referred to the System Reference Manual. However, the values L1 + L2 and W1 + W2 shall NEVER exceed 2 cm (representing 2% of the SID).

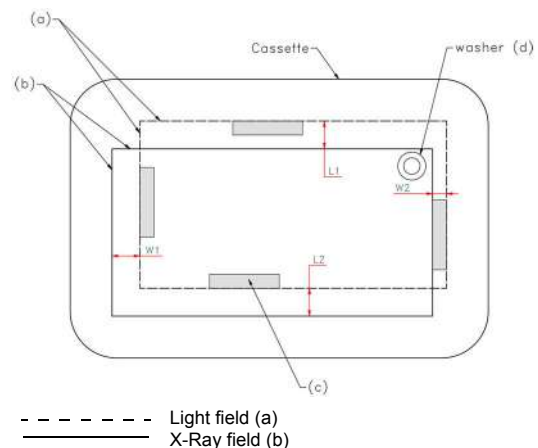

Fig: Check Light Field/X-ray Field

- Note the measured values in Chart below.
- Repeat preceding steps with small focus selected.

SID = 100 cm (40")			
2.0% x 100 cm (40") =			
LARGE FOCUS	L1+L2 W1+W2	= + =	= ≤ 2.0% SID
SMALL FOCUS	L1+L2 W1+W2	= + =	= ≤ 2.0% SID

Collimator to Focal Spot Alignment (Primary Shutter Cut-Off)

Inspect the four sides of the field formed by the four collimator shutters. The four edges of the x-ray field must be sharp. A definitely indistinct edge indicates that the primary shutter, close to the focal spot, is the one forming the line, rather than the outermost shutter.

To correct the condition:

- Dismount the collimator from the flange and the flange from the X-ray tube.
- Insert the four flathead screws in countersunk spacers supplied with the collimator.
- Re-mount the flange on the X-ray tube by placing it on position previously marked by pen.
- Fasten (not tighten) the four flathead screws with about 20/30 cNm of force. This will allow the operator to shift the flange and the collimator.
- By using a piece of plastic rod of appropriate length and width and a hammer move the flange in the direction and the distance of the indistinct edge.
- Centre another cassette 35x43 cm in place of the cassette previously marked with masking tape.
- Check that the collimator shutters are open to the size of 30x30 cm (12"x12") at 1 m FFD (SID).
- Turn the light ON and place 18 coins on the perimeter of the light field.
- Set the x-ray generator to produce a density of about 50 kVp, 5 mAs.
- Make another exposure and check that the edges of the x-ray field are all sharp.
- Repeat the above steps until the collimator is aligned with the focal spot then remove the collimator from the flange, tighten the four flathead screws M6 and re-mount the collimator on the flange.



THE HEEL EFFECT WILL CAUSE THE FIELD TOWARD THE CATHODE TO BE SLIGHTLY LESS SHARP THAN ON THE OTHER THREE SIDES. THIS IS NORMAL AND CANNOT BE CORRECTED BY ADJUSTMENT. IN ADDITION, AN X-RAY TUBE OF 12 ° OR LESS TARGET ANGLE WILL PRODUCE AN ASYMMETRICALLY SHAPED FIELD WHEN A LARGE FIELD SIZE IS USED AT SHORT FFD (SID), BECAUSE OF ANODE CUT-OFF EFFECT. THIS IS NORMAL AND MAY NOT BE CORRECTED BY ADJUSTMENT.

LIGHT FIELD TO X-RAY FIELD ALIGNMENT

Misalignment of the light field/ X-ray field in either the X (cross table) or Y (long table) direction must not exceed 2% of the SID. In this case, it would be less than 20 mm (0.80"). If the test film

shows that the light field (shadows of the copper strips) matches the X-ray field (shadow of the collimator shutters) to within the diameter of one strips and, if the diameter is less than 20 mm (0.80"), then alignment complies with the regulations.

Greater precision than this is possible. Recommended maximum deviation is one fourth. It is important the greatest degree of congruency possible is achieved.

If misalignment is detected in both X and Y directions, check the spacing from the focal spot to the collimator mounting surface is 80 mm (3.14") +/- 1 mm. If spacing needs to be adjusted, repeat the test film exposure after the adjustment.

If the source flange distance (**SFD**) is correct, but adjustment is still necessary proceed as follows:

- Place the test film on the face of the cassette over the white paper or repeat exposure on the flat panel.
- Place the cassette in the position originally marked.
- Check the correct position of the film or the X-ray field on the flat panel by the shadows cast by the copper strips.
- Using the images of the collimator shutters as the references for the shape and size of the X-ray field, adjust the light field to match.
- If adjustment is necessary, adjust the travel of the light source. All procedures can be found in **LIGHT FIELD ADJUSTMENTS** in this chapter.

LIGHT FIELD CALIBRATION

Vertical Alignment

- Remove the part of the cover necessary to access the screws, see Chapter - **COVER REMOVAL**.
- If adjustment is required loosen the two screws **C** holding the light support.
- If the light-field is smaller than the X-ray field, move away the light source by adjusting screw **D**.
- If the light-field is bigger than the X-ray field, move the light source closer by adjusting screws **D**.
- Tighten the two screws **C**. See ***Fig. Light Field Adjustment***

Longitudinal Alignment (Long)

WARNING



DO NOT TOUCH THE DISSIPATER WITH YOUR HANDS; IT COULD BE HOT AND CAUSE SEVERE BURNS.

- Remove part of the cover, see Chapter - **COVER REMOVAL**.
- If the light-field needs to be moved laterally, loosen (not remove) the fixing screws **A**.
- Use screw **B** to adjust transversely.
- When calibration is terminated, lock the screws **A**. See ***Fig. Light Field Adjustment***

Light Field Adjustment

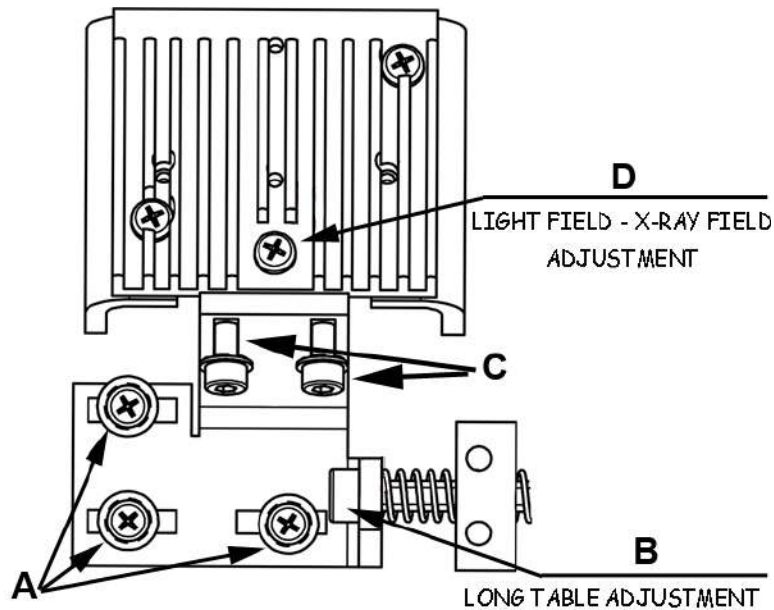

Vertical Alignment

- If the light field is *smaller* than the X-ray field, lower the lamp by adjusting screw **C**.
- If the light field is *bigger* than the X-ray field, raise the lamp by adjusting screw **C**.

See **Fig. Light Field Adjustment**.

Transversal Calibration (CROSS)

Fig. Transversal Calibration

If the light-field needs calibration, the mirror needs to be adjusted as follows:

- Remove the part of the cover necessary to access the screws, see Chapter - **COVER REMOVAL**.
- Loosen the mirror fixing screw **A** (not remove) and rotate the cam **B** to adjust the position of the mirror, see **Fig. Transversal Calibration (CROSS)**.
- Once you have regulated the mirror tighten the screw **A** and remount the cover, see Chapter - **COVER REMOVAL**.

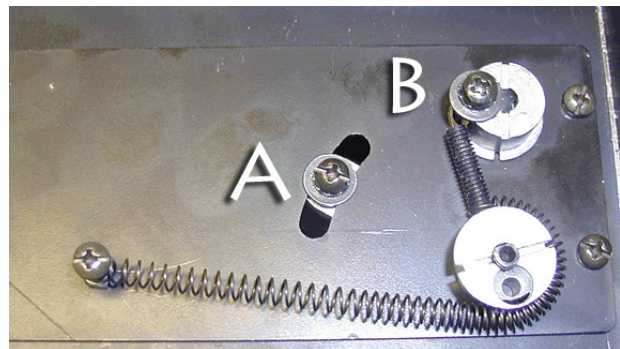

COMPLIANCE VERIFICATION

MINIMUM FILTRATION REQUIREMENT

To indicate compliance with 21 CFR, sub-chapter J, part 1020 of Performance Standard it is necessary for the assembler to perform a series of tests.

Description of test methods are illustrated in this chapter but factors, such as experience, availability of equipment and tolerance on compliance are referred directly to the Safety Standards covering Electro-medical equipment.

WARNINGS



THE FOLLOWING PROCEDURES REQUIRE THAT X-RADIATION BE PRODUCED. TAKE ADEQUATE PRECAUTIONS THAT NO PART OF HUMAN BEING IS EXPOSED TO X-RADIATION, DIRECT OR INDIRECT.

The above HVL requirements can be met if it is demonstrated that the aluminium equivalent in the primary beam is not less than that shown in the following table:

Minimum Filtration Requirement - Beam Quality (HVL)				
X-Ray Tube Voltage (kilovolt peak)		Minimum HVL (mm of aluminum)		
Designed Operating Range (kVp)	Measured Operating Potential (kVp)	Specified Dental System ¹	I-Other X-Ray Systems ²	II-Other X-Ray Systems ³
Below 51	30	1.5	0.3	0.3
	40	1.5	0.4	0.4
	50	1.5	0.5	0.5
From 51 a70	51	1.5	1.2	1.3
	60	1.5	1.3	1.5
	70	1.5	1.5	1.8
Above 70	71	2.1	2.1	2.5
	80	2.3	2.3	2.9
	90	2.5	2.5	3.2
	100	2.7	2.7	3.6
	110	3.0	3.0	3.9
	120	3.2	3.2	4.3
	130	3.5	3.5	4.7
	140	3.8	3.8	5.0
150	4.1	4.1	5.4	

¹ Dental X-ray Systems designed for use with intraoral image receptors and manufactured after December 1, 1980.

² Dental X-ray Systems designed for use with intraoral image receptors and manufactured before or on December 1, 1980, and all other X-ray systems subjected to this section and manufactured before June 10, 2006.

³ All X-ray systems, except dental X-ray systems designed for use with intraoral image receptors subjected to this section and manufactured on or after June 10, 2006.

The information contained in the above table was extracted from the Code of Federal Regulations FDA 21 1020.30 (m).

Type 100 Aluminium Alloy (as given in “ALUMINUM STANDARDS AND DATA” verification of compliance).

Visual Determination of Half-Value Layer (HVL)

The above HVL requirements can be met if it is demonstrated that the aluminium equivalent in the primary beam is not less than that shown in the following Total Filtration table:

Total Filtration Of Primary Beam In Aluminium Equivalence	
Operating Voltage (kVp)	Total Filtration (mm Al Equivalent)
Below 50	0.5
From 51 to 70	1.5
Over 70	2.2

The Aluminium equivalence of each component in the primary beam (X-ray tube and housing, beam limiting device and any additional filtration in the system) is specified on the component, in the technical data attached to the component or can be measured. Determine the total aluminium equivalence in the primary beam and make sure that it is equal or greater than those specified in the above **Table Total Filtration of Primary Beam in Aluminium Equivalence**.

Quick-Check of Minimum Filtration Requirement at a Particular kVp

If the total inherent filtration cannot be seen, then the HVL must be obtained with the following procedures:

The HVL in millimetres of aluminium in the system under test must be compared with those specified in **Table Minimum Filtration Requirement - Beam Quality (HVL)** and must be greater than or equal to the values shown in the table.

- a) Direct the central X-ray beam perpendicular and in the center of a RAD-Check instrument. Determine the exact distance from the X-ray tube focal spot to the window of the collimator (273 mm - 10.75"). Place the input area of the RAD-CHECK at an equal distance from the collimator window. Collimate the beam to an area slightly larger than the detector.
- b) Make an exposure at a pre-selected technique factor of 90 kVp and appropriate mA and time values with no added filtration in the beam; record the reading. Using the type 1100 Aluminium Alloy, tape a total of 2.5 mm of Aluminium to the window of the collimator. Make an exposure using the same technique factors; record the reading.
- c) Verify that the radiation read with the 2.5 mm Al in the beam is greater or equal to 50% of the radiation read with no filtration in the beam.

Standard Absorber Method

The HVL determination obtained from the following procedures are to be compared with those illustrated in the **Table - Minimum Filtration Requirement - Beam Quality (HVL)**. The HVL

R225 - R225 DHHS - Compliance Verification

in millimetres of aluminium obtained during the test must be greater or equal than the values listed in the above mentioned table.

- a) Direct the central X-ray beam perpendicular and in the center of a RAD-Check instrument. Determine the exact distance from the X-ray tube focal spot to the window of the collimator (273 mm - 10.75"). Place the input area of the RAD-CHECK at an equal distance from the collimator window. Collimate the beam to an area slightly larger than the detector.
- b) Select a tube potential of 100 kVp and appropriate mA and seconds, with no added filtration in the beam make an exposure and record the reading. Using a set of several sheets of 1100 Aluminium Alloy, each having a thickness of 0.5 or 1.0 mm, tape the filtration to the window of the collimator. Make an exposure for each increments of filtration and record the reading.
- c) Plot the exposure readings (log scale) versus the total added filtration thickness on semi-log paper; see the sample hereunder.
- d) Verify that HVL values in the useful beam for the above specific tube potential is not less than the values shown in **Table - Minimum Filtration Requirement - Beam Quality (HVL)**.

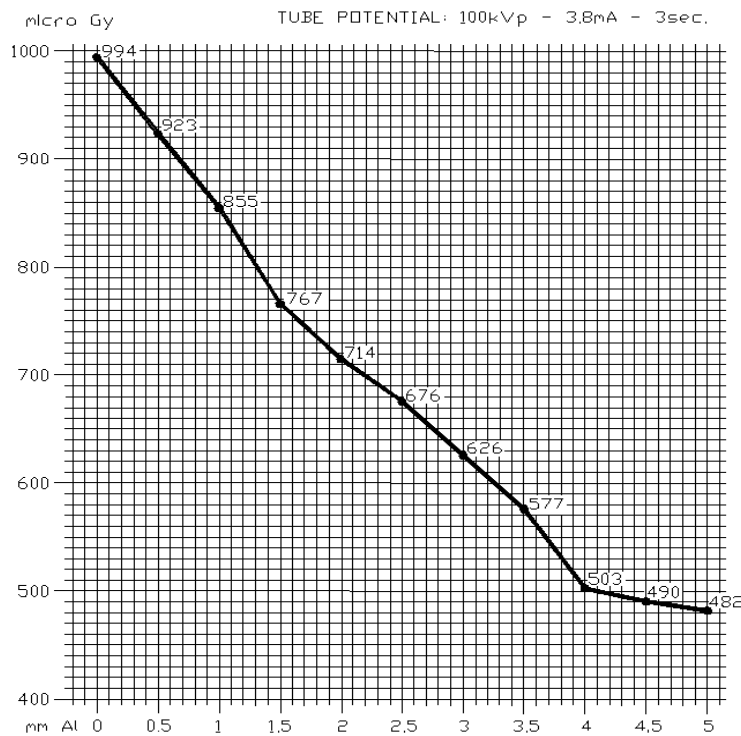

generate\12_verif_conf_graph.gif

R225 - R225 DHHS - Compliance Verification

VISUAL DEFINITION OF X-RAY VERSUS LIGHT FIELD

Chapter - **COLLIMATOR CALIBRATION** - paragraph - **Light-Field to X-ray Field Alignment.**

FIELD SIZE INDICATION

Chapter- **ADJUSTMENTS**, paragraph **Field Size Indication.**

CROSSHAIR ALIGNMENT

CHAPTER- ADJUSTMENTS, PARAGRAPH CROSSHAIR ALIGNMENT.

LIGHT FIELD ILLUMINATION INTENSITY

- a) When a light field simulating the X-Ray field is used the illumination provided at 100 cm. cannot be less than: 160 lux [(21 CFR 1020.31 (d) (2) (ii)].
- b) Place the Focus of the X-Ray tube at 100 cm. from the table top were the light field as been projected. Open the collimator's shutters to assure that each quadrant of the light field is larger than the measuring area of the photometer.
- c) Check that the voltage specified by the manufacturer is applied to the lamp, make certain that all surfaces in the light beam are clean and unobstructed.
- d) Place a photometer capable of reading up to 160 lux in the centre of each of the four quadrants of the light field.
- e) Turn on the light beam and read the light intensity, subtract to it the ambient lighting, previously determined.
- f) Verify that the average illumination is higher than 160 lux.
- g) Verify that the contrast ratio is performed between two points:
 - The first point at 3 mm outside the edge of the light field.
 - The second point at 3 mm inside the edge of the light field.These measurements are to be performed with the probe of the lux metre set at 1 mm aperture.
- h) Record the measured values including all data regarding the instrument and voltage employed.

EMC COMPLIANCE

The ME Equipment is intended to be used in the PROFESSIONAL EM ENVIRONMENTS.

WARNING



TO ASSURE THAT ACCESSORIES, TRANSDUCERS AND CABLES THAT CAN AFFECT THE EMISSIONS OR IMMUNITY OF THE ME EQUIPMENT, ACCESSORIES, TRANSDUCERS AND CABLES ARE CHOSEN THAT WILL ALLOW THE ME EQUIPMENT TO CONTINUE TO MEET THE EMISSIONS AND IMMUNITY REQUIREMENTS OF THIS COLLATERAL STANDARD.

Electromagnetic Emissions

The R225 - R225 DHHS collimator is suitable for use in the specified electromagnetic environment. The purchaser or user of the R225 - R225 DHHS should assure that it is used in an electromagnetic environment as described below:

Emissions Test	Compliance	Electromagnetic Environment- Guidance
RF emissions CISPR 11	Group 1	The Collimator R225 - R225 DHHS uses RF energy only for its internal function. Therefore, its RF emissions are very low and are not likely to cause any interference in nearby electronic equipment.
RF emissions CISPR 11	Class B	This R225 - R225 DHHS is suitable for use in all establishments, including domestic establishments and those directly connected to the public low-voltage power supply network that supplies buildings used for domestic purposes.
Harmonic emissions IEC 61000-3-2	Class A	
Voltage fluctuations/flicker emissions IEC 61000-3-3	Complies	

Electromagnetic Immunity for All Equipment and Systems

Collimator R225 - R225 DHHS is intended for use in the electromagnetic environment specified below. The customer or the user should assure that it is used in such an environment.

Immunity Test	IEC 60601 Test Level	Compliance Level	Electromagnetic Environment
Electrostatic discharge (ESD) IEC 61000-4-2	8 kV contact 2/4/8/15 kV air	EN 60601-1-2 test level	Floors should be wood, concrete or ceramic tile. If floors are covered with synthetic material, the relative humidity should be at least 30%.
Radiated electromagnetic field IEC 61000-4-3	3 V/m 80 MHz to 2.7 GHz	IEC 60601-1-2 Test level	Portable and mobile RF communications equipment should be used no closer to any part of the collimator R225 - R225 DHHS, including cables. Minimum distance 30 cm
Electrical fast transient/burst IEC 61000-4-4	2 kV for power supply lines 1 kV for input/output lines >3m	EN 60601-1-2 test level	Mains power quality should be that of a typical commercial or hospital environment.
Surge IEC 61000-4-5	0.5/1 kV differential mode 0.5/1/2 kV common mode	EN 60601-1-2 test level	Mains power quality should be that of a typical commercial or hospital environment.
Conducted disturbances induced by RF fields IEC 61000-4-6	3 V 150 kHz to 80 MHz 6V ISM frequencies	IEC 60601-1-2 Test level	Portable and mobile RF communications equipment should be used no closer to any part of the collimator R225 - R225 DHHS, including cables. Minimum distance 30 cm
Voltage dips, short interruptions and voltage variations on power supply input lines IEC 61000-4-11	10 ms – 0% a 0°, 45°, 90°, 135°, 180°, 225°, 270°, 315° 20 ms – 0% a 0° 500 ms – 70% a 0° 5 s – 0%	EN 60601-1-2 test level	Mains power quality should be that of a typical commercial or hospital environment. If the user of the collimator R225 - R225 DHHS requires continued operation during power mains interruptions, it is recommended that the collimator R225 - R225 DHHS be powered from an uninterruptible power supply or a battery.
Power frequency (50/60 Hz) magnetic field IEC 61000-4-8	30 A/m	EN 60601-1-2 test level	Power frequency magnetic fields should be at levels characteristic of a typical location in a typical commercial or hospital environment.

Frequency Range and Level: RF wireless communication EQUIPMENT

Collimator R225 - R225 DHHS is intended for use in the electromagnetic environment specified below. The customer or the user should assure that it is used in such an environment.

Test Frequency (MHz)	Modulation	Minimum IMMUNITY Level (V/m)	IMMUNITY Level Applied (V/M)
385	**Pulse Modulation: 18 Hz	27	27
450	*FM ± 5 Hz deviation: 1 kHz sine **Pulse Modulation: 18 Hz	28	28
710 745 780	**Pulse Modulation: 217 Hz	9	9

R225 - R225 DHHS - Compliance Verification

Frequency Range and Level: RF wireless communication EQUIPMENT

810 870 930	**Pulse Modulation: 18 Hz	28	28
1720 1845 1970	**Pulse Modulation: 217 Hz	28	28
2450	**Pulse Modulation: 217 Hz	28	28
5240 5500 5785	**Pulse Modulation: 217 Hz	9	9

COVER REMOVAL

(1).

REMOVE THE TWO KNOBS BY UNSCREWING THE DOWEL.



(2).

REMOVE CAREFULLY THE SNAP-ON FRONT PANEL. DISCONNECT THE CONNECTOR.



(3).

REMOVE THE TAPE STOP BY LIFTING IT OFF WITH A SCREW DRIVER. GENTLY EASE THE TAPE INTO ITS CONTAINER WITHIN THE COLLIMATOR.



(4).

TURN THE COLLIMATOR OVER AND UNSCREW THE FOUR SCREWS PLACED ON THE RAILS.



(5).

**REMOVE THE REAR COVER
BY UNSCREWING THE FOUR
SCREWS.**



(6).

**REMOVE THE LATERAL
COVER BY LIFTING IT OFF
FROM THE TWO SPACERS.**



ADJUSTMENTS

WARNINGS



THIS IS PROVIDED AS AN AID TO THE END USER. RALCO IS NOT LIABLE FOR ANY DAMAGES RESULTING FROM THE ALTERING OF PRESET FACTORY CONFIGURATIONS.

ADJUSTMENTS HAVE BEEN PRESET AT THE FACTORY PRIOR TO SHIPMENT OF THE COLLIMATOR. SHOULD ANY PROBLEM ARISE REQUIRING THE NEED TO RECALIBRATE, PLEASE CONTACT RALCO FOR ASSISTANCE BEFORE PROCEEDING WITH THE ADJUSTMENT.

FIELD SIZE INDICATION ADJUSTMENT

EN60601-1-3- par. 29.201.8

Regulations state that collimators must indicate the size of the X-Ray field at the SID in use to within 2% of that SID.

Shutter Dial Adjustment

- Rotate the two control knobs to completely close both sets of shutters. Use the field light to check that the shutters are in fact closed.
- Rotate the knobs and make the knob index coincide exactly with the scale reading that corresponds to size 30x30 cm at 1 m SID.
- Measure the X-ray field of the test image.
- If the reading is not correct, adjust the indicator using the screws on the sides of each knob.

CROSSHAIR ADJUSTMENT

- Activate the light field.
- Adjust the light field to a narrow line for each pair of shutters by turning the two knobs alternately.
- Check that the project cross line is exact halfway between the edges of the shutters, see **Fig. Cross Line**.
- If adjustment is required, remove the cover from the sides and bottom of the collimator, see Chapter - **COVER REMOVAL**.
- Loosen the four screws securing the plastic panel and adjust the cross lines to coincide with the light lines, see Chapter - **COVER REMOVAL**.
- Tighten the screws.



Fig. Cross Line

FRICION BRAKE ADJUSTMENT

If the shutter movement is too loose or too tight, proceed as follows:

- Remove the parts of the cover to access the adjustment point, see Chapter- **COVER REMOVAL**.
- If a shutter control is too loose and does not hold position, tighten one of the two screws **A** on the U bolt that frictions the shaft, see **Fig. Friction Brake**.
- If a shutter control is too tight, loosen one of the two screws **A** on the U bolt that frictions the shaft, see **Fig. Friction Brake**.

Fig. Friction Brake

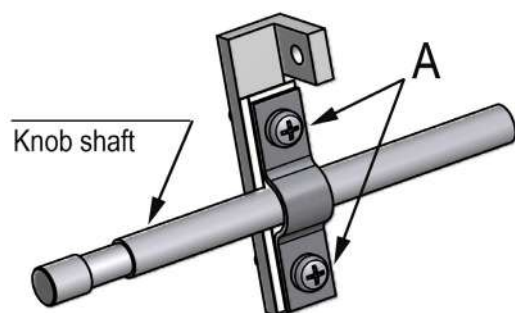

- Before replacing the knobs, close both shutters and mount/fix the knobs so that the field index is set at "0" (completely closed), see paragraph **Shutter Dial Adjustment** in this Chapter.

MECHANICAL MOTION STOP ADJUSTMENT

The purpose of these stops is to prevent stressing the control shafts of the shutters at the two limits of travel. This is done by limiting rotation of the control shafts.

- Adjustment of these stops will not be required unless:
 - The shutters can not be completely closed or opened to the largest size.
 - Torsion is felt at one or both ends of the travel.
 - The shutters themselves appear to limit the motion rather than the stops.

Fig. Long & Cross Shutters

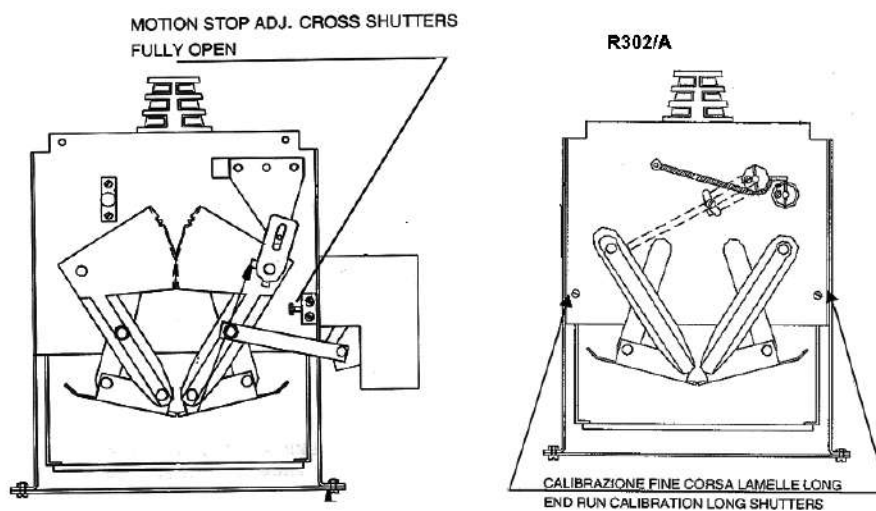

CLOSED Stop Long and Cross Shutters

The stop is effected by a cam

- Loosen the Allen screw placed on the side of the stop. See **Fig. Closed Stop**
- Use the knob to close the shutters. Take care not to apply excessive force to check that the shutters touch.
- Use the field light to check that shutters are closed.
- Rotate the cam stop to a stand still.
- Tighten the Allen screw.
- Open and close the shutters several times to check that they close/open fully and that, when they close, the cam touches the stop.

Fig. Closed Stop

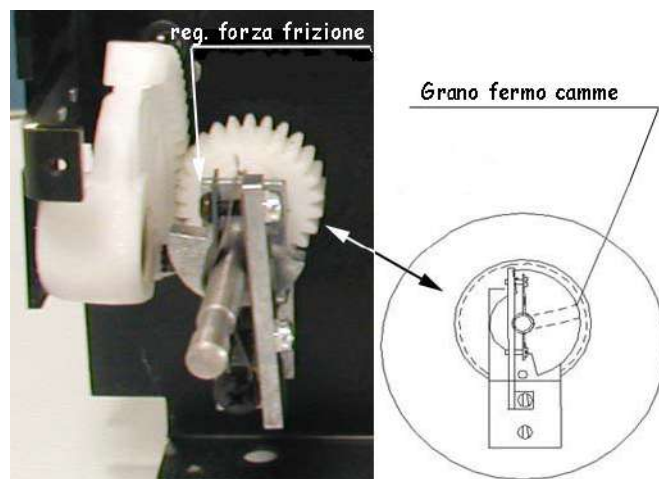

TROUBLESHOOTING

A faulty Collimator must not be used until it is repaired and checked.

The use of a faulty collimator might impair the safety of the operator and patient.

Before returning the collimator to Ralco for repair, please make sure that the fault is not caused by one of the problems listed below. If the indications provided fail to solve your fault, **please make sure that you obtain a Return number (RMA) from Ralco for the collimator**, see Chapter - **GENERAL**, paragraph **Repairs**.

GENERAL FAULT FINDING

Function	Fault Description	Fault finding and solutions
Light	Faulty light source	<ul style="list-style-type: none"> Check if power supply is OK (see chapter SPECIFICATION) Check if LED power supply is + 3 V If still NOK, replace LED (see chapter SUBSTITUTIONS)
	Faulty timer	<ul style="list-style-type: none"> Check if power supply is OK (see chapter SPECIFICATION) Check if timer board is supplied Check if fan operates when pressing the push button on the front panel Check if green diode place on the timer is ON when pressing the push button on the front panel. If NOK, replace the timer board (see chapter SUBSTITUTIONS)
	Area defined by Light Field not (completely) on film	<ul style="list-style-type: none"> Check if source flange distance is correct (see chapter INSTALLATION) Check if mirror or light source are positioned correctly (see chapter CALIBRATION) If still NOK, exchange the collimator.
	Faulty ON/OFF push-button	<ul style="list-style-type: none"> Check contact If NOK, replace the front panel

Function	Fault Description	Fault finding and solutions
Collimator calibration	The light field of the collimator is not centered	<ul style="list-style-type: none"> Check if mirror or light source are correctly positioned (see chapter CALIBRATION, paragraph Light Field to X-Ray Field Alignment) If still NOK, replace collimator

Function	Fault Description	Fault finding and solutions
Shutters	Shutter close	<ul style="list-style-type: none"> Check if friction is loose If still NOK, replace friction

INDICATORS GC-LED-4A

Number	Color	Description	Fault finding and solutions
LED1	Green	+12 V DC or +24 V DC	<p>In case LED1 is OFF:</p> <ul style="list-style-type: none"> check if +12/+24 V is present; LED1 should be ON if still NOK, check if system cables are connected correctly to GC-LED-4A if still NOK, replace GC-LED-4A (see chapter SUBSTITUTIONS) if still NOK, replace collimator (see chapter SUBSTITUTIONS)
LED2	Yellow	Software version	<ul style="list-style-type: none"> check if LED2 blinks 4 times if NOT, wrong software version, replace collimator (see chapter SUBSTITUTIONS)

LED3	Red	Alarms	
			<p>1 blink: Disconnected LED of Driver failure</p> <ul style="list-style-type: none"> • check if LED is connected correctly • if still NOK, replace LED • if still NOK, replace GC-LED-4A (see chapter SUBSTITUTIONS) • if still NOK, replace collimator (see chapter SUBSTITUTIONS) <p>2 blinks: LED short circuit</p> <ul style="list-style-type: none"> • remove the short circuit • if still NOK, replace LED • if still NOK, replace GC-LED-4A (see chapter SUBSTITUTIONS) • if still NOK, replace collimator (see chapter SUBSTITUTIONS) <p>3 blinks: Fan failure or disconnected</p> <ul style="list-style-type: none"> • check if fan is connected correctly • if still NOK, replace fan (see chapter SUBSTITUTIONS) • if still NOK, replace GC-LED-4A (see chapter SUBSTITUTIONS) • if still NOK, replace collimator (see chapter SUBSTITUTIONS) <p>4 blinks: Laser failure or disconnected</p> <ul style="list-style-type: none"> • check if laser is connected correctly • if still NOK, replace laser (see chapter SUBSTITUTIONS) • if still NOK, replace GC-LED-4A (see chapter SUBSTITUTIONS) • if still NOK, replace collimator (see chapter SUBSTITUTIONS) <p>5 blinks: push button pressed longer than 5 seconds or short-circuited</p> <ul style="list-style-type: none"> • check if push button works properly • remove short circuit if present • if still NOK, replace GC-LED-4A (see chapter SUBSTITUTIONS) • if still NOK, replace collimator (see chapter SUBSTITUTIONS) <p>6 blinks: PCB temperature > 105°</p> <ul style="list-style-type: none"> • switch OFF the collimator for 10 minutes

SUBSTITUTIONS

LED SUBSTITUTION

WARNING



NOT IMMEDIATELY TOUCH THE DISSIPATER WITH YOUR FINGERS IT COULD BE HOT AND CAUSE SEVERE BURNS.



DO NOT TOUCH THE LIGHT SOURCE, THE SOCKET, OR THE LIGHT BRACKET WITH YOUR FINGER. THEY CAN BE VERY HOT AND CAUSE SEVERE BURNS.



DO NOT TOUCH THE LED LENS WITH YOUR FINGERS DIRECTLY, EVEN WHEN IT IS COLD. OIL FROM YOUR SKIN WILL LOWER THE LED PERFORMANCE. IF YOU HAVE TOUCHED THE LED, WIPE THE LED SURFACE WITH A SOFT CLOTH IN CASE OF CONTACT.

The LED Substitution Kit is composed of the following components: the LED (A), and an extension cable (B), pictured in **Fig. LED Substitution Kit**. This Kit is designed to substitute any LED Ralco provides.

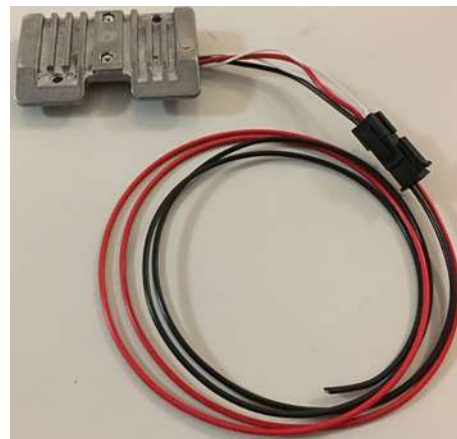
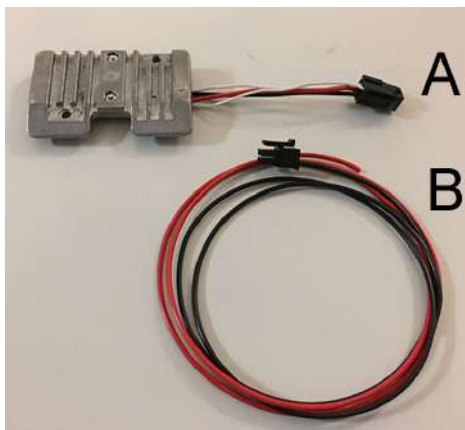

Fig. LED kit

Prior to replacing the LED, confirm which version of LED is installed on your collimator which will ensure the substitution is performed correctly.

- The previous version LED is connected to the board via 2 cables (red and black), see **Fig. Previous Version LED** below.

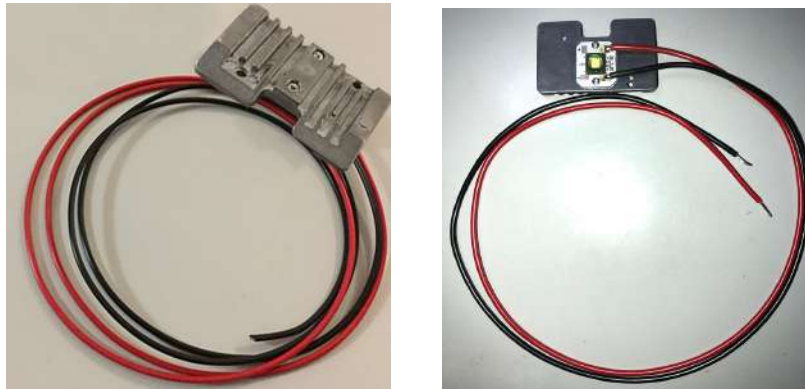

Fig. Previous Version LED

- The new LED is connected to the board via the connector, see **Fig. New Version LED** below.



Fig. New Version LED

Replacing the Previous Version LED

To replace the previous version of LED, both components of the LED Substitution Kit (A and B) must be used.

To substitute the LED, proceed as follows:

- Disconnect the collimator supply.
- Remove the cover, see Chapter - **COVER REMOVAL** in the Instruction Manual for your specific model.
- Remove the LED heat sink protection by unscrewing the 2 screws **C**, see **Fig. LED Substitution** below.
- Prior to disconnecting the LED cables from the board, identify the cables and their position on the terminal board, see Chapter **INSTALLATION**, paragraph **Wiring Diagram** in the Instruction Manual for your specific model.
- Carefully remove the LED and the extension cable from their packaging.
- Make sure that the extension cable (**B**) is firmly connected to the LED (**A**), see **Fig. LED kit**.
- Adjust the length of the extension (**B**) cable by cutting the 2 cables (red/black).
- Connect both cables to the board.
- Remount the heat sink protection by tightening the two fixing screws (**C**), see **Fig. LED Substitution** below.
- Remount the covers in reverse order, see Chapter **COVER REMOVAL**.
- Verify the Light Field/X-Ray field correspondence, see Chapter **CALIBRATION**.

Replacing the New Version LED

To replace the new version LED, only part A of the Kit must be used.

To substitute the LED, proceed as follows:

- Disconnect supply.
- Remove the cover, see Chapter **COVER REMOVAL**.
- Remove the LED heat sink protection by unscrewing the 2 screws **C**, see **Fig. LED Substitution** below.
- Detach the connector of the faulty LED from the collimator wiring.
- Substitute the LED with an identical item by using the part **A** of the LED Substitution Kit.
- Remount the heat sink protection by tightening the 2 fixing screws **C**, see **Fig. LED Substitution** below.
- Remount the covers in reverse order, see Chapter **COVER REMOVAL**.
- Verify the Light Field/X-Ray field correspondence, see Chapter **CALIBRATION**.

Fig. Led Substitution

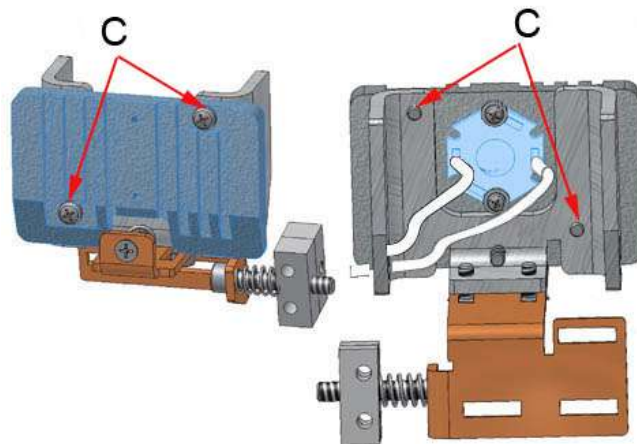

SUBSTITUTION OF THE ELECTRONIC BOARD FOR LED

The PCB Substitution Kit is composed of the following components: the board (A), an extension cable (B)* and 8 jumpers (C), pictured in opposite **Fig. PCB Substitution Kit**. This Kit is designed to substitute the previous version of the timer board for LED.

(B)* - The extension cable is added only if the collimator model is equipped with the additional filtration and with the indicator diode place on the front panel. In other cases, is useless and it will not be added to the PCB Substitution Kit.

To substitute the timer board, proceed as follows:

1. Disconnect the collimator supply.
2. Remove the cover, see Chapter **COVER REMOVAL** in the Instruction Manual for your specific model.
3. Prior to disconnecting the cables from the board, identify the cables and their position on the terminal board, see Chapter **INSTALLATION**, paragraph Wiring Diagram in the Instruction Manual for your specific model
4. Carefully remove the timer board, the extension cable and the jumpers from their packaging.

The next 3 steps are applicable only to the collimator equipped with the additional filtration and the indicator diode placed on the front panel.

- Insert the extension cable (B) in the J4 connector, placed on the new timer board, see **Fig. 2 Extension Cable**.
 - Detach the connector from the faulty timer board, see **Fig. 3 Connector Removal** below.
 - Connect the unplugged connector to the extension cable (B), see **Fig. 4 Extension Cable Connection** below.
5. Remove the 2 screws holding the timer board.
 6. Install the new timer board by proceeding in a reverse order; pay particular attention to the connection of the cables on the 2 or 8-way electric terminal.
 7. Correctly set up the board by using the 8 jumpers (C) according to the Jumper Setting description here below. See Chapter **INSTALLATION**, paragraph Wiring Diagram and GC-LED-4 in the Instruction Manual for your specific model for further information.
 8. Remount the covers in reverse order, see Chapter **COVER REMOVAL**.
 9. Verify the Light Field/X-Ray field correspondence, see Chapter **CALIBRATION**.

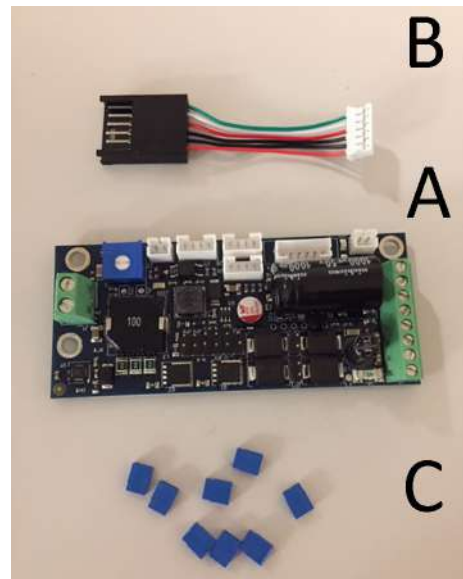

Fig. PCB Substitution Kit

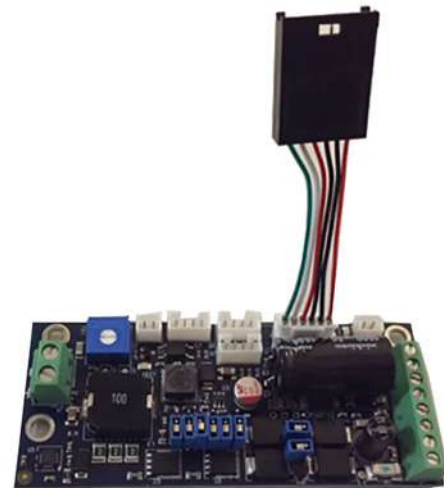

Fig. Extension Cable

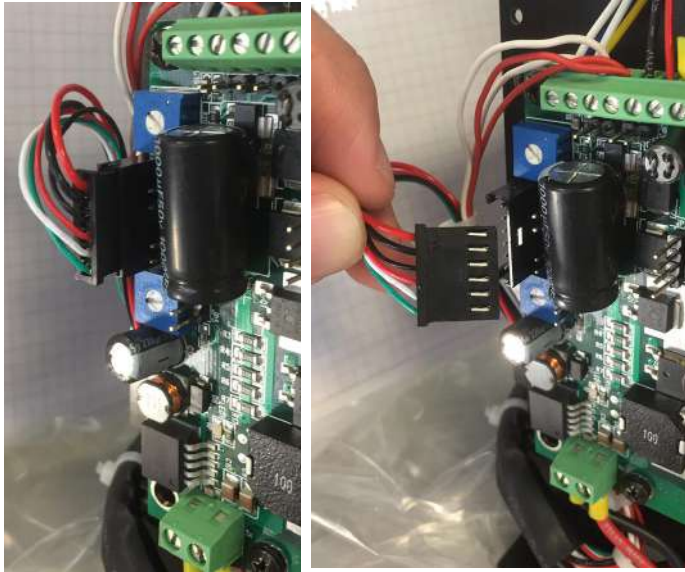

Fig. Connector Removal

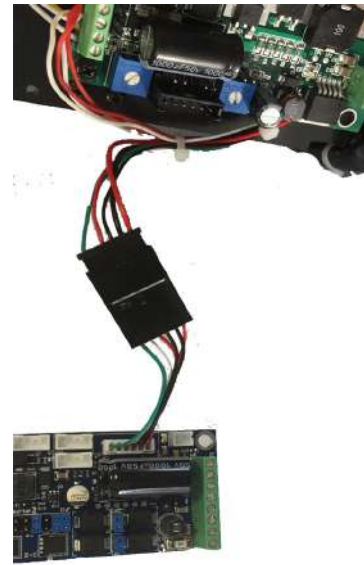

Fig. Extension Cable Connection

SUBSTITUTION OF THE MIRROR

- Remove the collimator cover, front panel and rear cover, see Chapter-**COVER REMOVAL**.
- Remove the collimator lateral protection walls.
- Remove the mirror shaft stop on the left side of the collimator.



- Remove the three screws on the upper left partition.

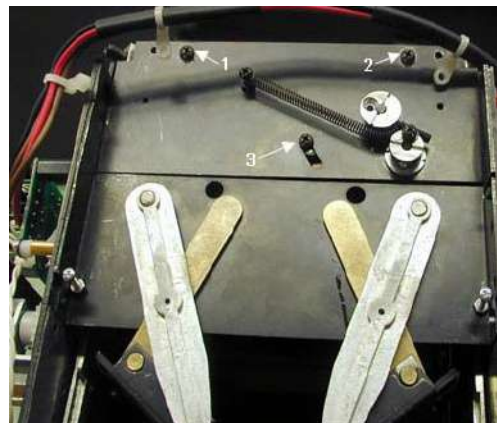

- Remove the two screws on the cable stops.

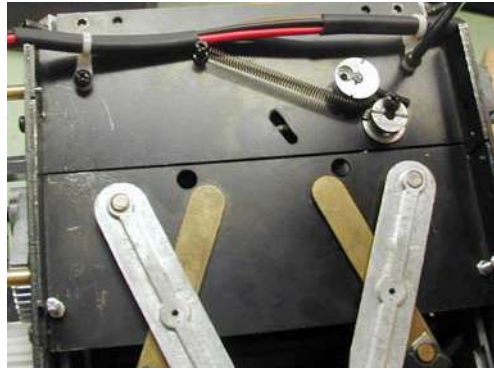

- Remove the cable stop located on the front partition of the collimator on the upper right hand side.

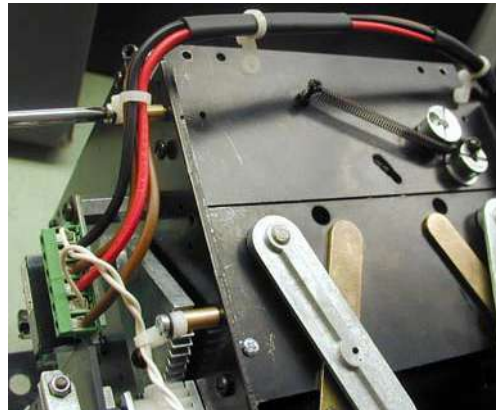

- Remove the screw on the rear partition of the collimator on the upper left hand side.

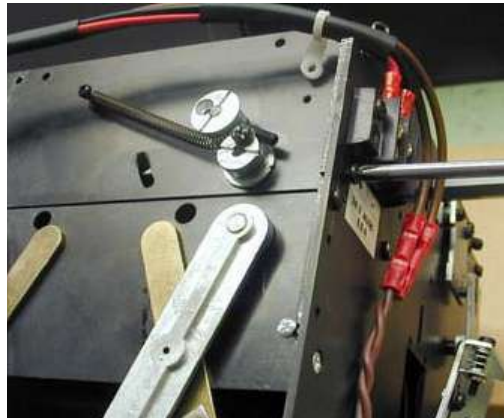

- Lift off the upper part of the right hand partition.

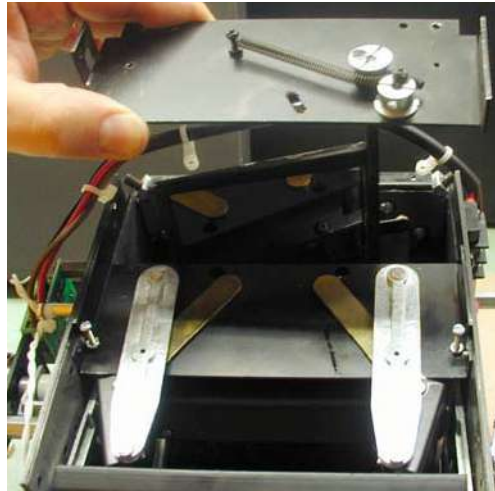

- Substitute the mirror and remount in reversed order.

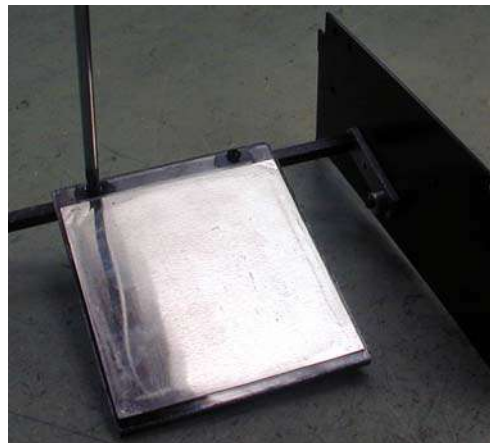

SPARE PARTS

NOTE



WHEN ORDERING SPARE PARTS, THE CUSTOMER IS REQUESTED TO SPECIFY THE COLLIMATOR MODEL AND SERIAL NUMBER.



THE SPARE PARTS LISTED BELOW REFER TO THE STANDARD MODEL ONLY.



PLEASE CONSULT YOUR PERSONALIZATION PAGE TO VERIFY WHICH SPARE PARTS MAKE UP YOUR CUSTOMIZED MODEL

LABELS

LABEL 1A

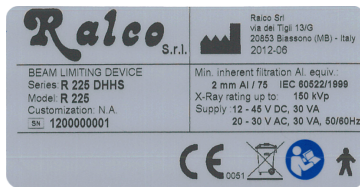

LABEL 1B



LABEL 2

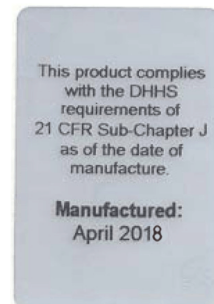

LABEL 3A

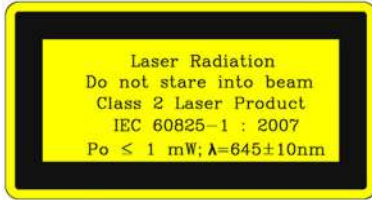

LABEL 3B



LABEL 4



LABEL 5



LABEL 6



LABEL 7

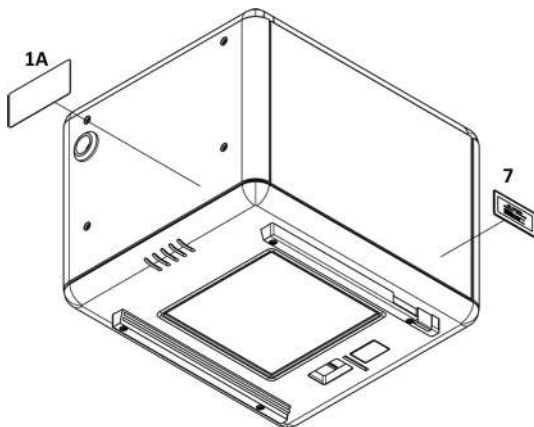
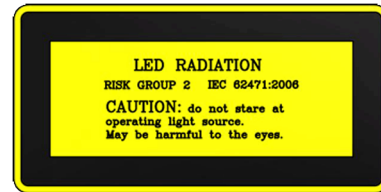

Fig. Standard Label

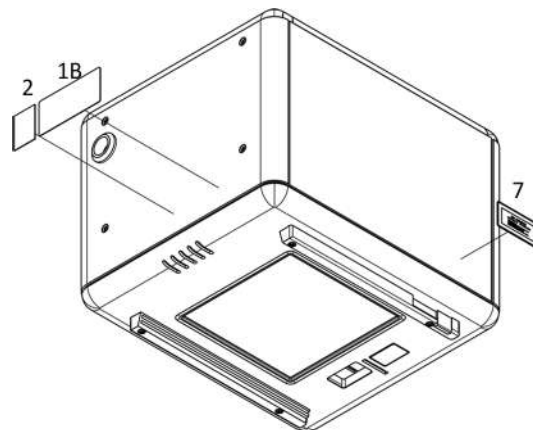

Fig. DHHS Labels

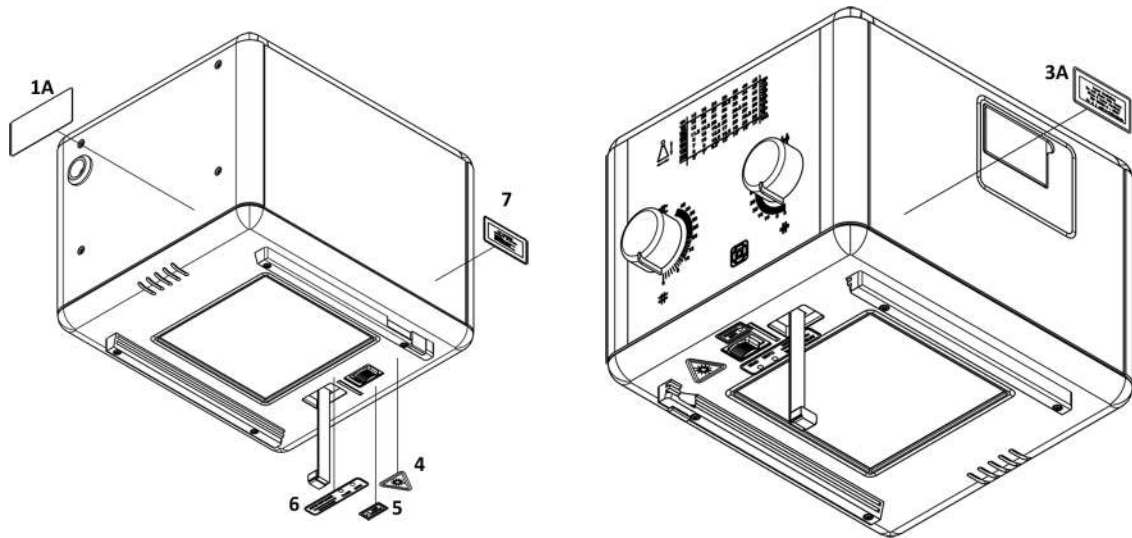

Fig. Standard Model Labels, LED (optional RO 333) and Laser (Red Laser Line - optional RO 242/1)

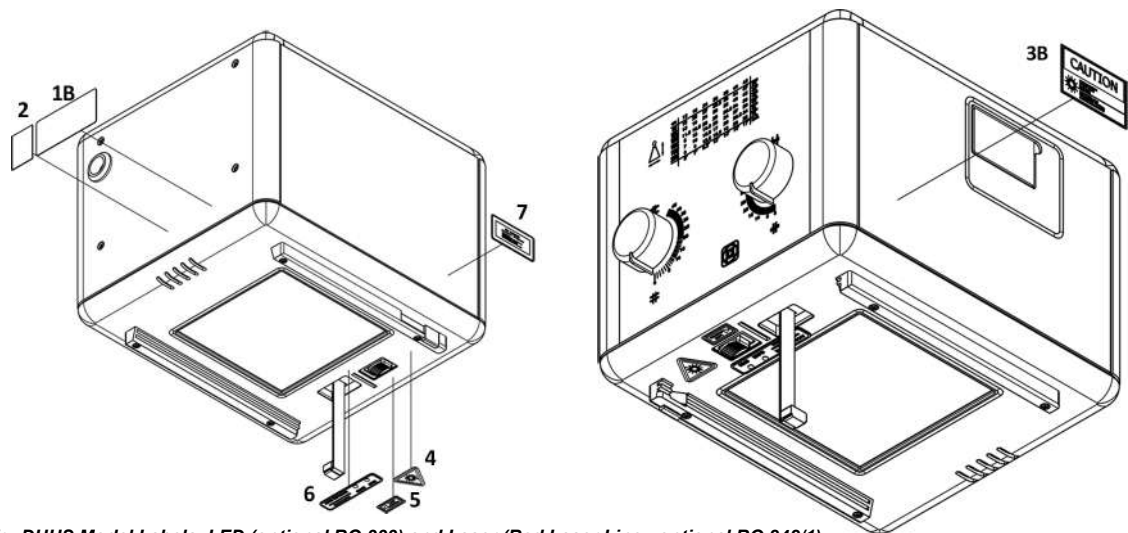

Fig. DHHS Model Labels, LED (optional RO 333) and Laser (Red Laser Line - optional RO 242/1)

R225 - R225 DHHS STANDARD

PN	Description
RS 093/A	Glass mirror, 1.7 mm thickness
RS 178	Knob
RS 596	Screw, TC M3x25 mm
RS 754	Right accessory guide
RS 755	Left accessory guide
RS 940	Lateral access panel
RS 1012	Mounting flange
RS 1106	Fan
RS 1159	Front panel with push-button

R225 - R225 DHHS - Spare Parts

PN	Description
RS 1160	Rear cover
RS 1161	Antidust panel
RS 1259	Right lateral cover
RS 1260	Left lateral cover
RS 1261	Upper cover
RS 1333	Lower cover
RS 2539	LED board
RS 2586	LED

Parts Breakdown

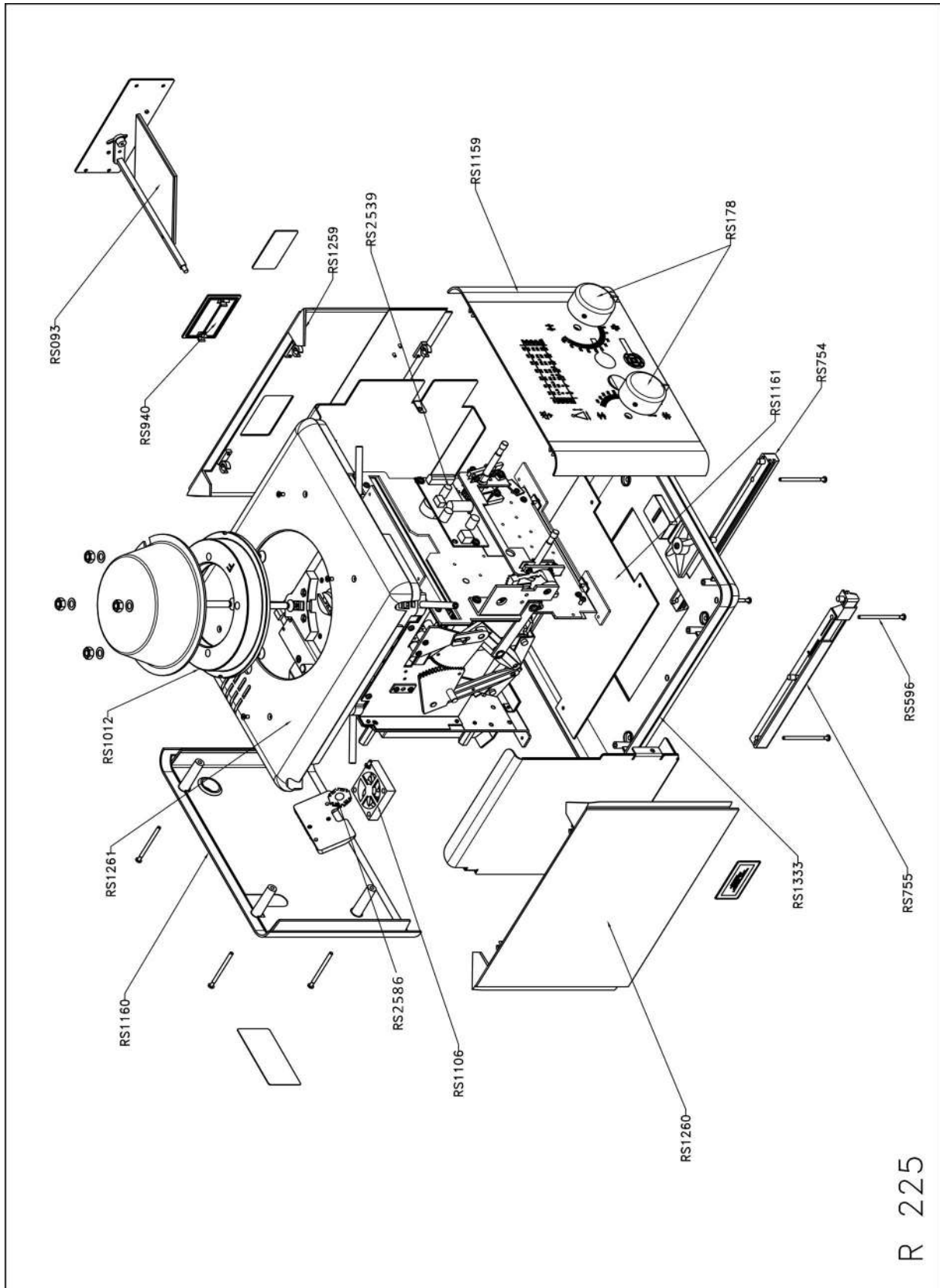

R225 - R225 DHHS - Spare Parts

OPTIONAL ITEMS

This collimator may have the following optional items; a detailed description is provided in this chapter.

RO 002 Iron Mounting Flange Spacer

This accessory is used for the mounting flange; 1.5 mm thickness.

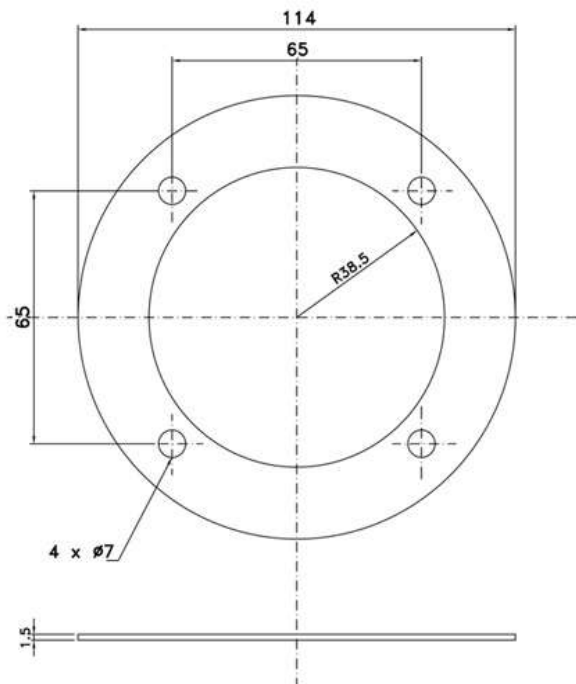

RO 012/B Retractable Measuring Tape

Mounted on a radiological unit, measures the distance between the focus and the patient.

NOTE



USE OF THE RETRACTABLE TAPE MEASURE IN COLLIMATORS WITH THIS FEATURE: THE TYPE OF TAPE MEASURE USED IS A STANDARD TAPE MOUNTED ON A RADIOLOGICAL UNIT. THE TAPE STARTS WITH VALUES THAT CORRESPOND TO THE FOCUS/COLLIMATOR LOWER EDGE DISTANCE; MAXIMUM RADIOLOGICAL MEASUREMENT WITH THE TAPE IS 2 M MAX EVEN THOUGH, FOR PURELY MECHANICAL REASONS, MAXIMUM TAPE EXTENSION IS 3 M MAX. STOP IS EVIDENT IMMEDIATELY AFTER THE MAXIMUM MECHANICAL VALUE.

FORCING AND/OR EXTENDING THE TAPE BEYOND THIS POINT WILL CAUSE THE FOLLOWING INCONVENIENCES:

BREAKAGE OF THE TAPE OR,
DISTORTION OF THE TAPE OR,

IMPOSSIBILITY OF RETRACTING THE TAPE INTO ITS LODGING BECAUSE THE GRIP OF THE SPRING HAS BEEN FORCED AND HOOK-UP IS CONSEQUENTLY DISTORTED.
NOTE: DO NOT EXTEND THE TAPE BEYOND THE INDICATION OF STOP.

RO 041 Mylar Mirror

Mylar mirror, internal filtration equivalent at minimum 0.3 mm Al.



RO 063 Final Quality Test Report Documentation

This test provides higher control to check 100% of the production lot to verify product quality from beginning to end of the production cycle.

Final tests include:

- Light field illumination intensity (if applicable),
- Light field to X-ray field alignment (if applicable),
- X-ray leakage test,
- Edge contrast (if applicable),
- Operation and electronic check up.

RO 074 External housing and guide rails in customized color

The customer can specify a collimator cover color. Ralco's standard color is RAL9003.

RO 077 Light Centring Device to align collimator to detector

This centring device of the Potter Bucky (BL). Reflects the lamp light to form a bright line to align collimator to Potter Bucky.

Adjustment

- Remove the collimator rear cover to gain access to the point of adjustment, see Chapter **COVER REMOVAL**.
- The line is to fall on a perpendicular bisector line constructed against the anti-dust plastic panel toward the control face of the collimator.
- To adjust the position of the line, shift the light support group as required. Note that the support group and bracket are inside the collimator frame and cannot be seen, but may be controlled by the two securing screws **A**, see **Fig. Centering Device Adjustment**.

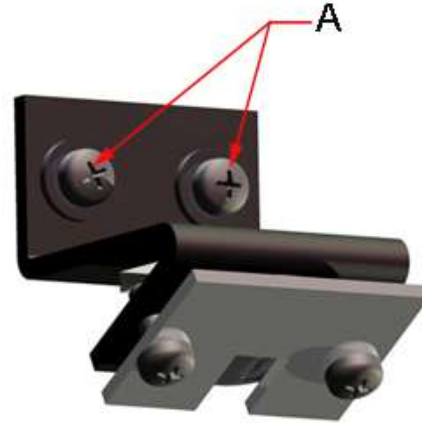

Fig. Centering Device Adjustment

RO 082 Glass Mirror

Glass mirror, 0.8 mm thickness, inherent filtration 1 mm Al equivalent. With this mirror, the collimator equivalent filtration value of 2 mm Al is reduced to 1 mm Al.

RO 096 Wiring Customization

Customized electrical wiring. If ordered please refer to the **Personalizations**, annex included with this Instruction Manual, Chapter – Installation, paragraph **Wiring Diagram**.

RO 107 Knob Color Customization

The customer can specify the required knob color.

RO 111 Front panel customization

The customer can customize the front panel adding, for example, the Company Logo and/or the Company colors.

RO 203 Self-centering top-cover bracket for Siemens X-Ray tube

This bracket is designed for Siemens X-Ray tube only (flange provided by Siemens only).

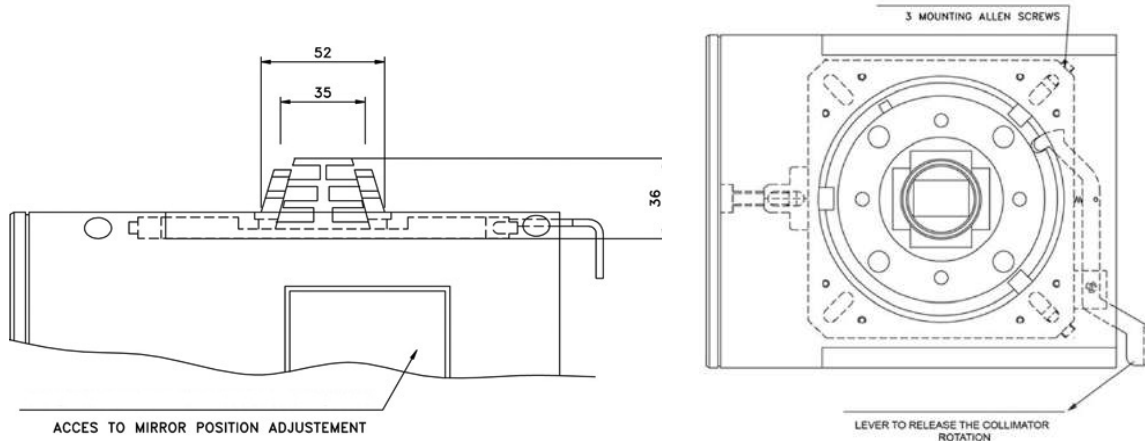

NOTE



RALCO RECOMMENDS FOLLOWING THE BELOW PROCEDURE, DURING THE INSTALLATION OF THE COLLIMATOR EQUIPPED WITH THE SIEMENS TOP COVER TO THE X-RAY TUBE. THE CORRECTLY PERFORMED PROCEDURE ALLOWS THE COLLIMATOR TO ROTATE FREELY.

PROCEDURE:

1. REMOVE THE COLLIMATOR FROM ITS PACKAGING AND PLACE IT ON A FLAT SURFACE,
2. UNSCREW ALL 3 FIXING SCREWS OF THE COLLIMATOR, SEE **FIG. 1**,
3. INSTALL THE COLLIMATOR ONTO THE FLANGE PREVIOUSLY MOUNTED TO THE X-RAY TUBE.
4. TIGHTEN ALL 3 SCREWS COMPLETELY, SO THAT THE TABS WILL TOUCH THE FLANGE SLIGHTLY,
5. ONCE THE SCREWS ARE COMPLETELY TIGHTENED LOOSEN ONE BY ONE ABOUT 1/2 TURN (180°) TO ALLOW THE COLLIMATOR TO ROTATE FREELY. SEE **FIG. 2**.

Fig. 1

Fig. 2

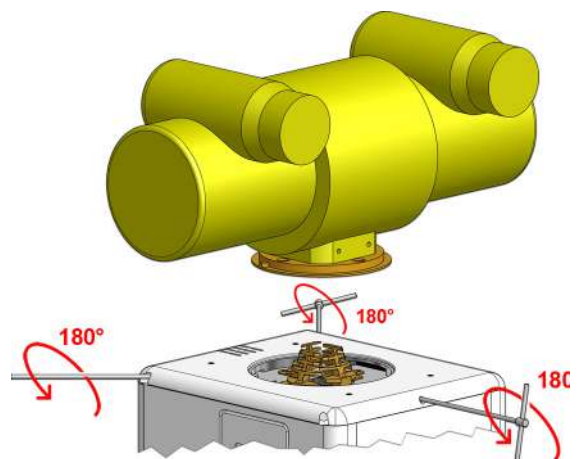
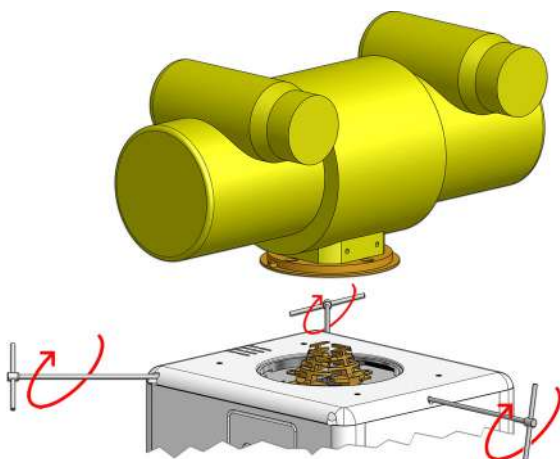

RO 240 Focal-spot to skin spacer

This accessory ensures a minimum safety distance (309.5 mm) between the X-ray focus and the patient.



THIS ACCESSORY DEALS WITH PREVENTING THE USE OF INAPPROPRIATE SMALL FOCUS/SKIN DISTANCES IN ORDER THAT THE DOSE EQUIVALENT TO THE PATIENT BE KEPT AS LOW AS REASONABLY POSSIBLE.

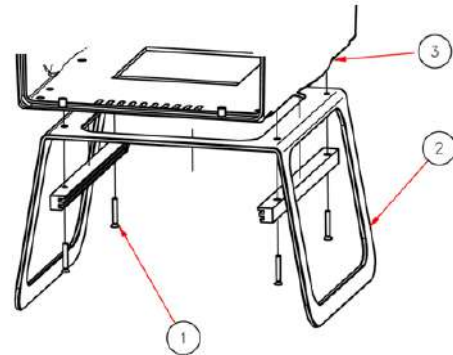

1 - Countersunk Screws, 2 - Focus-Skin Distance Spacers, 3 - Collimator Cover.

RO 242/1 Single Laser Line Projection

The collimator laser is classified as Class 2 (1 m W - wavelength = 645 nm +/- 10 nm); used for collimator/image receptor center alignment, see **Fig. Laser Line**.

WARNING



CAUTION: CLASS 2 LASER SYSTEM DO NOT STARE INTO THE BEAM

Laser Adjustment

- Remove part of the cover to access the point of adjustment, see Chapter- **COVER REMOVAL**.
- The line is to fall on a perpendicular cross-line on the plastic anti-dust panel near the collimator controls, see **Fig. Laser Line**.
- Adjust the position of the line by rotating or moving the base of the laser system.
 - To rotate the laser system, loosen the Allen screw **A**, see **Fig. Laser Adjustment**.
 - Tighten the Allen screw when the laser beam falls on or is parallel to the bisector line drawn on the anti-dust panel.
- Shift the laser system by loosening the two **B** screws holding the laser system base to the beam limiting device front plate.
 - Move the base until the laser beam falls over the perpendicular bisector line on the anti-dust panel, see **Fig. Laser Alignment**.
 - Tighten the two **B** screws.

WARNING



DO NOT APPLY EXCESSIVE FORCE TO THE SCREW. THE LASER SHELL IS IN PLASTIC AND EXCESSIVE PRESSURE COULD CRACK THE PLASTIC AND POSSIBLY SHORT-CIRCUIT THE LASER.

Fig. Laser Line

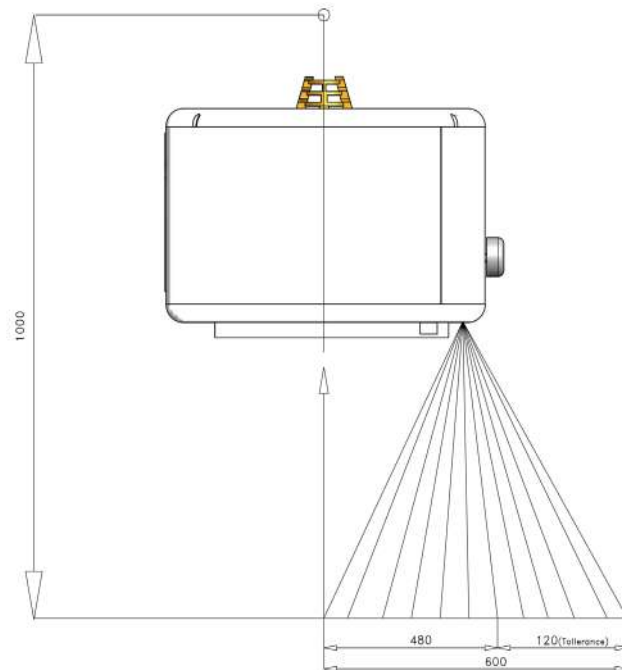

Fig. Laser Adjustment

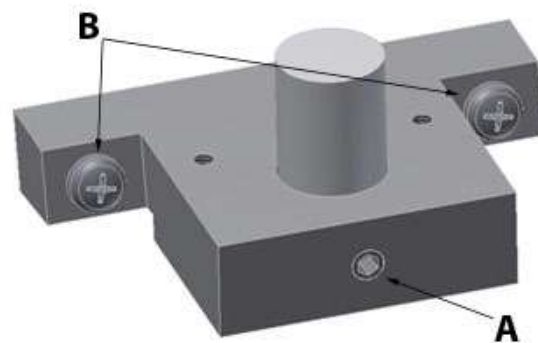
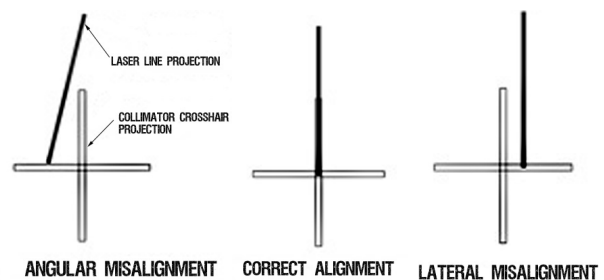

Fig. Laser Alignment



R225 - R225 DHHS - Optional Items

Substitution

- Disconnect supply.
- Remove the cover, see Chapter- **COVER REMOVAL**.
- Unscrew the fixing Allen screws **A**, see **Fig. Laser Adjustment**.
- Disconnect the timer cables from the terminal board - white 0 V, red 5 V.
- Remove the laser and substitute with an identical item.
- Tighten the screws.
- Check the laser alignment, see Chapter- **ADJUSTMENTS**.
- Remount the cover, see Chapter- **COVER REMOVAL**.

Classification EN 60825-1 par. 1 -5: Class 2 laser product => Red laser line.

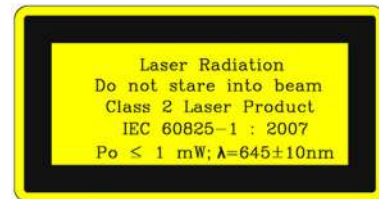

**RO 242/2 Two lasers forming a crosshair to center the patient to the collimator:
Class 2**

Second laser which serves to center the patient using the cross projection.

The collimator lasers are classified as Class 2 (1 m W - wavelength = 645 nm, +/- 10 nm) and are used for collimator/ image receptor center alignment.

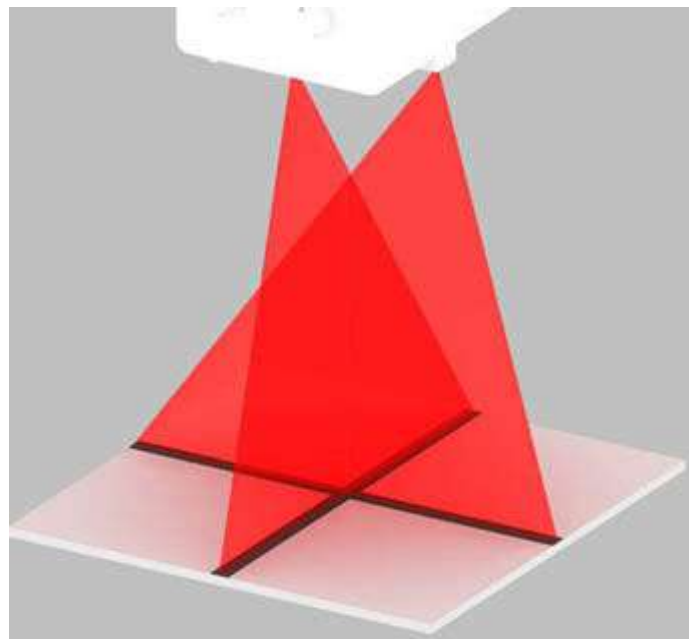

WARNING



CAUTION: CLASS 2 LASER SYSTEM DO NOT STARE INTO THE BEAM

Fig. Laser Adjustment

CALIBRATION CONTROL

- Draw a cross (two lines at 90°) on a sheet of paper and use this as reference.
- Switch the light ON and set the sheet of paper at 1 m from the focus.
- Make sure the cross on the paper coincides exactly with the two lines silk-screened on the plastic window.
- Examine the laser projections on the paper: the laser is correctly calibrated when the projections coincide with the lines drawn on the paper, otherwise an adjustment will be necessary.

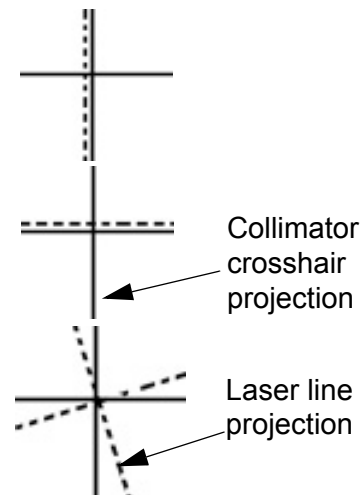

Fig. Laser projections

ADJUSTMENT

Horizontal

- Disconnect power supply.
- Remove the laser cover located on the rail by unscrewing the two screws **A**, see **Fig. Horizontal Laser**.
- To correct horizontal misalignment, loosen the screws **B**, see **Fig. Horizontal Laser** and move the laser support until the projected laser line coincides with the cross on the sheet of paper. Tighten screws **B**.

Vertical

- Disconnect power supply.
- Remove the knobs and front panel, see Chapter- **COVER REMOVAL**.
- To correct vertical misalignment, loosen the Allen screw **A**, see **Fig. Vertical Laser** on the laser support; rotate the laser and align the laser line over the cross on the sheet of paper. Tighten **B** screw s.

WARNING



DO NOT APPLY EXCESSIVE FORCE TO THE SCREW. THE LASER SHELL IS IN PLASTIC AND EXCESSIVE PRESSURE COULD CRACK THE PLASTIC AND POSSIBLY SHORT-CIRCUIT THE LASER.

SUBSTITUTION

Horizontal

- Disconnect supply.
- Remove the laser cover located on the rail by unscrewing the two screws **A**, see **Fig. Horizontal Laser**.
- Disconnect the timer cables from the terminal board - white 0 V, red 5 V.
- Remove the laser and substitute with an identical item.
- Tighten the screws.
- Check the laser alignment, see paragraph **ADJUSTMENT**.
- Remount the laser cover.

Vertical

- Disconnect supply.
- Remove the knobs and front panel, see Chapter- **COVER REMOVAL**.
- Loosen the Allen screw **A**, see **Fig. Vertical Laser** on the laser support.
- Disconnect the timer cables from the terminal board - white 0 V, red 5 V.
- Remove the laser and substitute with an identical item.

- Tighten the Allen screw.
- Check the laser alignment, see paragraph **ADJUSTMENT**.
- Remount the laser cover.

Classification EN 60825-1 par. 1 -5: Class 2 laser product => Red laser line.

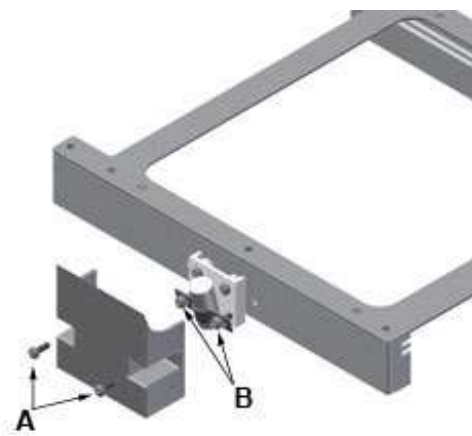
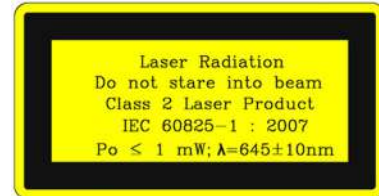

Fig. Horizontal Laser

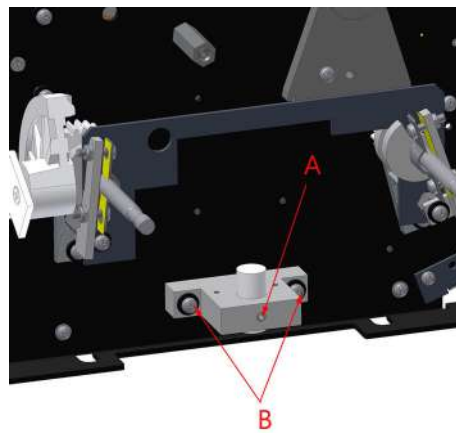

Fig. Vertical Laser

RO 258 Additional Variable Filtration - Manual Selection

Additional variable filtration with manual settings may be optionally added to the minimum collimator filtration in the form of a disk, 1 mm thickness, controlled manually from the front panel. The disk features a hole for the passage of X-rays and accommodates the following three filters:

- 0: no filtration
- 0,1 mm Cu + 1 mm Al. (Al eq. 3.5 mm)
- 0,2 mm Cu + 1 mm Al (Al eq. 6.0 mm)
- 1 mm Al + 1 mm Al support (Al eq. 2.0 mm).

Setup of Filters

- Rotate the aluminium disc that protrudes from the filter opening on the front panel.
- Indication of the filtration value is provided on the upper part and lower rim of the disc; this value refers to the additional filtration in the X-ray beam.

Substitution of Filter group

- Disconnect supply.
- Remove the front panel. See Chapter - **COVER REMOVAL**.
- Remove the filter support by unscrewing the 2 screw **A**. See **Fig. Filter Substitution**.
- Substitute the support with an identical part.
- Remount the support with a new filter - do not tighten the screws.
- Check that disc rotation is uniform: play must be reduced to a minimum.
- Tighten the 2 screws **A**.
- Remount the front panel.

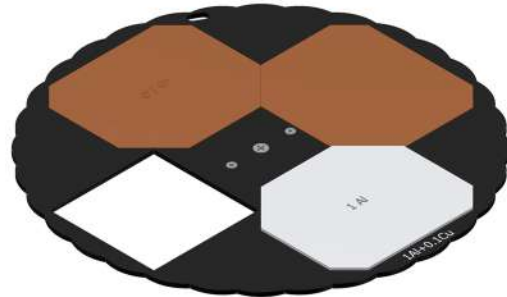

Fig. RO 258



Fig. Filter Substitution



RO 258/1 Additional Variable Filtration - Manual Selection

Additional variable filtration with manual settings may be optionally added to the minimum collimator filtration in the form of a disk, 1 mm thickness, controlled manually from the front panel. The disk features a hole for the passage of X-rays and accommodates the following three filters:

- 0: no filtration
- 0,1 mm Cu (Al eq. 2,5 mm)
- 0,2 mm Cu (Al eq. 5 mm)
- 0,3 mm Cu (Al eq. 7.5 mm)

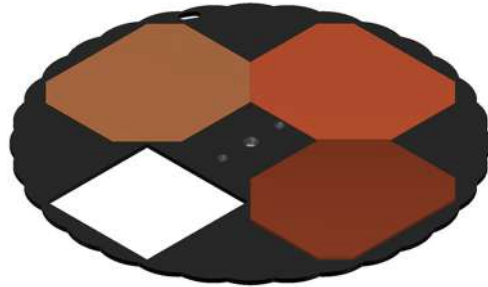

Fig. RO 258/1

To adjust and/or to change the filter see **RO 258 Additional Variable Filtration** description in this Chapter.

RO 318 Resin Rotating Mounting Flange

This optional item is included as a standard feature.

Please refer to the chapter **INSTALLATION** in this Instruction Manual for the correct flange/collimator mounting instructions.

RO 332/A Resin Rotating Mounting Flange

Resin rotating mounting flange with fixing screws:

- 15 mm thickness
- +/- 90° detent
- 140 mm diameter

Please refer to the chapter **INSTALLATION** in this Instruction Manual for the correct flange/collimator mounting instructions.

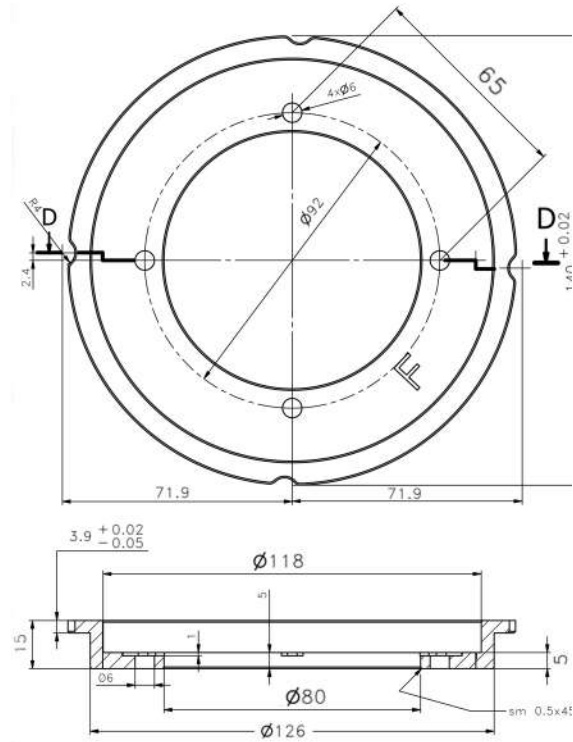

RO 344 Accessory guide rail spacers with reinforced support

Pair of plastic rail guides (RAL 9003) on metal support designed to accommodate the ionization chamber and allow the insertion of relative filter (178 mm +/- 0.5).

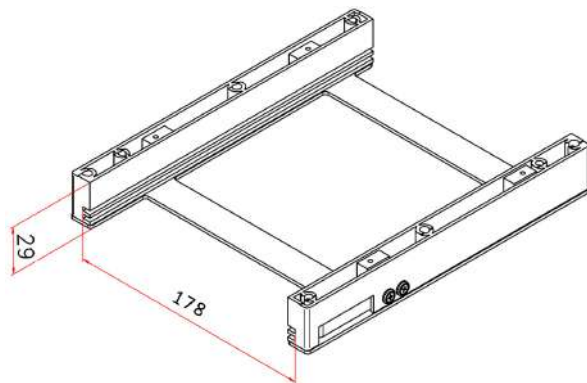

RO 356 Shutter position verified by potentiometer

Supplementary safety device to ensure correct positioning of shutters. It consists of two potentiometers mounted on the collimator: One is mounted on the back of the collimator to control the Long shutters and the other potentiometer is mounted on the side to control the Cross shutters. The output signal is managed by a customer.

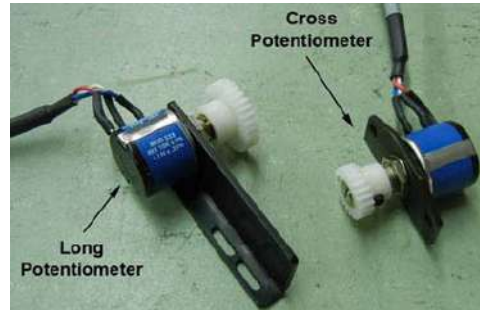

RO 369 Resin Rotating Mounting Flange

Resin rotating mounting flange:

- 20 mm thickness
- +/- 90° with mechanical stop
- 140 mm diameter

Please refer to the chapter **INSTALLATION** in this Instruction Manual for the correct flange/collimator mounting instructions.

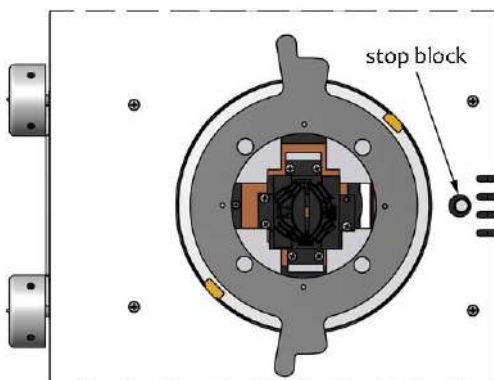
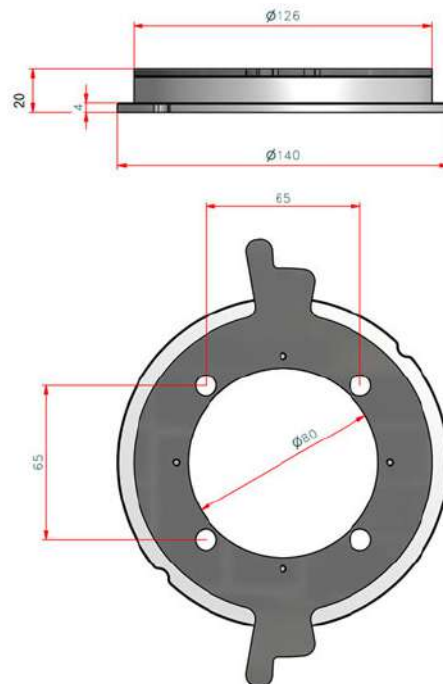

R225 - R225 DHHS - Optional Items

RO 370 Resin Rotating Mounting Flange

Resin rotating mounting flange:

- 20 mm thickness
- +/- 120° with mechanical stop
- 140 mm diameter

Please refer to the chapter **INSTALLATION** in this Instruction Manual for the correct flange/collimator mounting instructions.

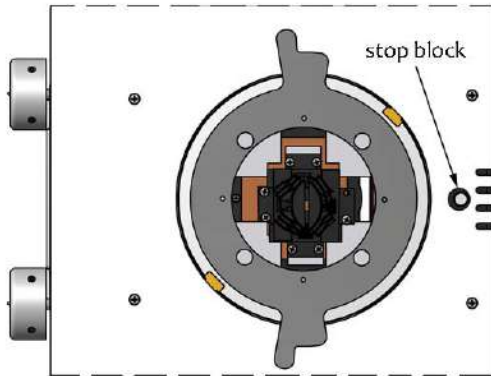
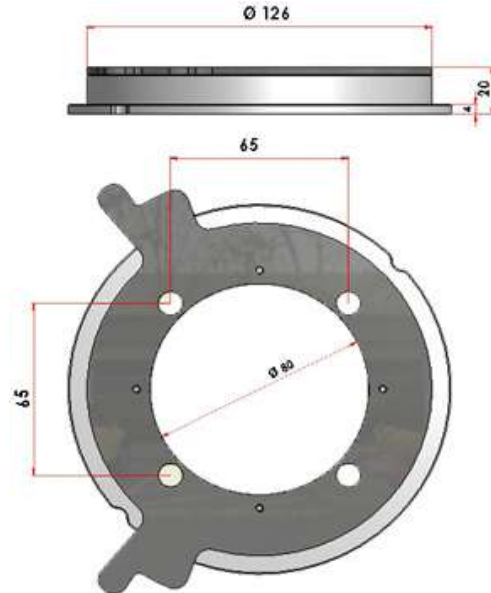

RO 409 Resin Rotating Mounting Flange

Resin rotating mounting flange milled to form a square:

- 20 mm thickness
- +/- 0° detent
- 140 mm diameter

Option includes three (3) iron mounting flange spacers also milled to form a square: 1.5 mm thickness.

Please refer to the chapter **INSTALLATION** in this Instruction Manual for the correct flange/collimator mounting instructions.

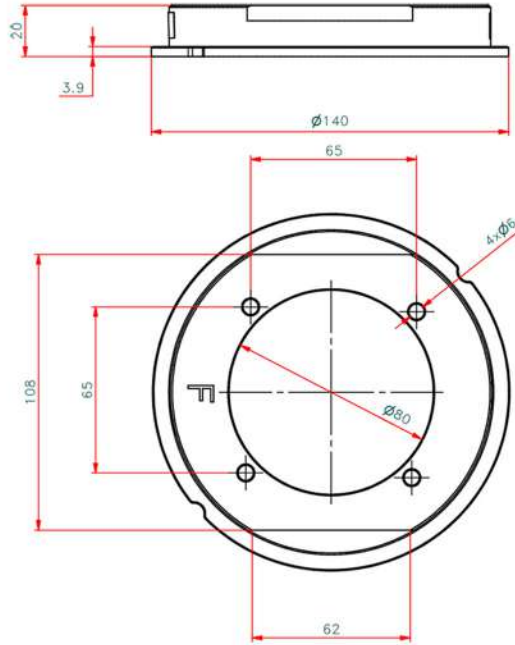

RO 441 Resin Rotating Mounting Flange

Resin rotating mounting flange:

- 20 mm thickness
- +/- 50° detent
- 140 mm diameter

Please refer to the chapter **INSTALLATION** in this Instruction Manual for the correct flange/collimator mounting instructions.

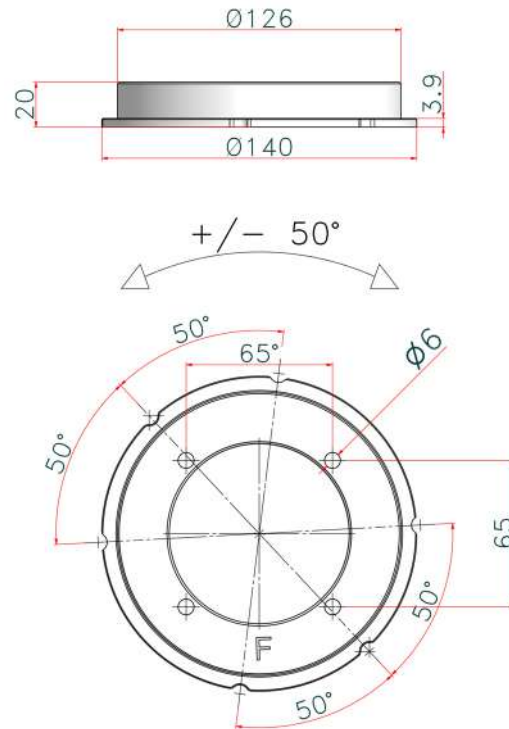

RO 442 Resin Rotating Mounting Flange

Resin rotating mounting flange:

- 20 mm thickness
- +/- 90° detent
- 140 mm diameter

Please refer to the chapter **INSTALLATION** in this Instruction Manual for the correct flange/collimator mounting instructions.

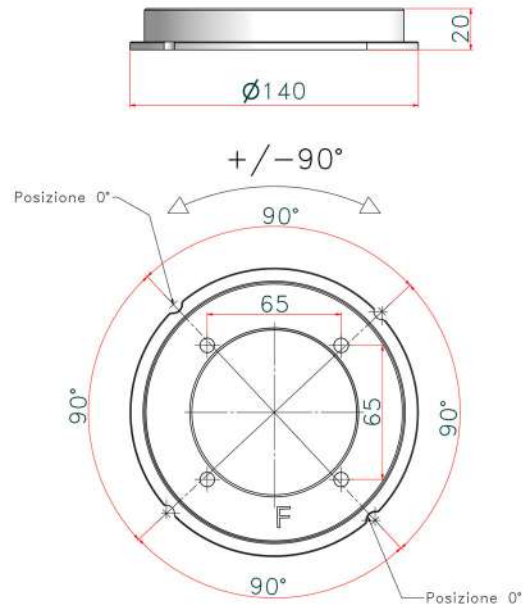

RO 445 Metal Rotating Mounting Flange

Metal rotating mounting flange:

- 20 mm thickness
- +/- 50° detent
- 140 mm diameter

Please refer to the chapter **INSTALLATION** in this Instruction Manual for the correct flange/ collimator mounting instructions.

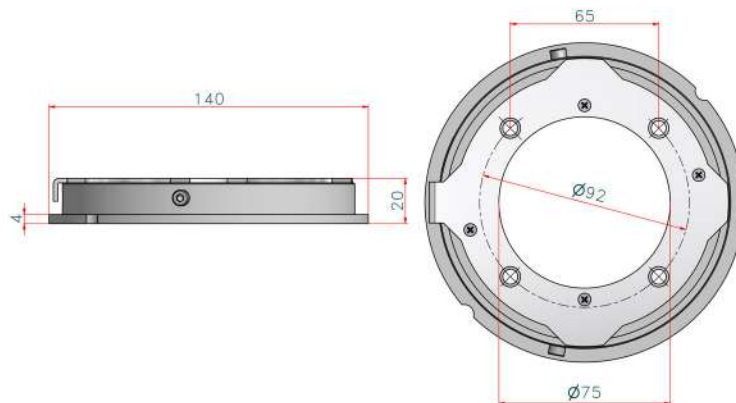

When the collimator is assembled check the collimator to Focal Spot Alignment (Primary Shutter Cut-Off).

Inspect the four images of the four collimator shutters which form the edges of the X-ray field. A definitely indistinct edge indicates that the primary shutter, close to the focal spot, is the one forming the line, rather than the outermost shutter.

To correct the condition, use the four mounting/centering adjustment screws to shift the collimator in the direction of the indistinct line. Repeat the test film exposure after making the adjustment.



THE HEEL EFFECT WILL CAUSE THE FIELD TOWARD THE CATHODE TO BE SLIGHTLY LESS SHARP THAN ON THE OTHER THREE SIDES. THIS IS NORMAL AND CANNOT BE CORRECTED BY ADJUSTMENT. IN ADDITION, AN X-RAY TUBE OF 12° OR LESS TARGET ANGLE WILL PRODUCE AN ASYMMETRICALLY SHAPED FIELD WHEN A LARGE FIELD SIZE IS USED AT SHORT SID, BECAUSE OF ANODE CUT-OFF EFFECT. THIS IS NORMAL AND MAY NOT BE CORRECTED BY ADJUSTMENT.

RO 452 Asymmetric Longitudinal Shutters (“stitching” application)

Each single Long shutter is moving through a knob on the front panel. This specialized system allows the user to manually adjust and fine-tune the stitch position. During the manual-stitching process, alignment of the Potter Bucky with the X-Ray beam is manually performed for each exposure.

The X-Ray tube remains stationary throughout the entire process. The acquired number of exposures is 3 at 100 cm SID. See **Fig. Stitching process.**



THE FRONT PANEL SHOWS THE 2 INDEX SCALES THAT ALLOWS THE COLLIMATOR TO OPERATE EITHER IN THE STANDARD OR STITCHING MODE. SEE **FIG. INDEX SCALE - STANDARD MODE** AND **FIG. INDEX SCALE - STITCHING MODE**. THE MAXIMUM COLLIMATOR APERTURE IN THE STITCHING MODE IS 43 X 43 CM AT 100 CM SID.

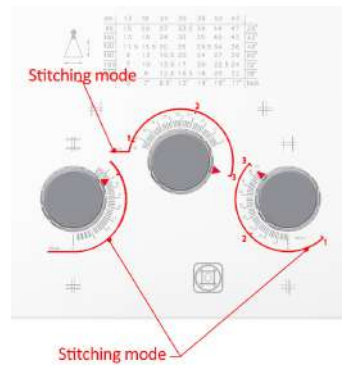
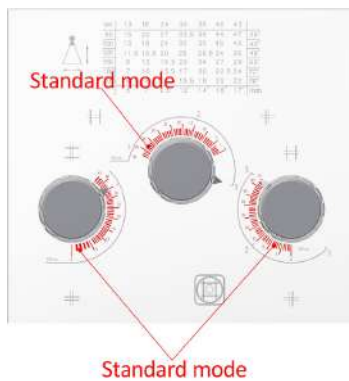

To use the collimator (with 3 knobs) in standard mode:

At the desired SID the operator has to select the proper field using the references in the silk screen board on the front panel.

e.g., if the operator wants to set an X-Ray field of 35 x 43 cm where 35 cm is given by the Cross shutter and 43 cm is given by the Long shutters, at SID 100 cm, the operator has to position the Cross knob (the knob on the left) on the value of the scale that indicates 35 and both the two Long knobs (the knob in the middle and the knob on the right) on the value of the scale that indicates 43. See **Fig. Index scale 35 x 43 cm**.



DO NOT USE A SINGLE LONG KNOB. YOU MUST ALWAYS USE BOTH LONG KNOBS TOGETHER, AND BOTH LONG KNOBS POSITIONED ON THE SAME DESIRED APERTURE (FIELD).

A single Long knob gets half the aperture selected. If you select the two Long knobs with different aperture, long field is misaligned with respect to the centre of the field (the centre of the cassette). To get an aligned field you must always use both Long knobs positioned on the same aperture (field) desired.

e.g., at SID 100 cm, to have an X-Ray field 43 cm (Cross) x 15cm (Long), the Cross knob must be positioned at 43 and both the 2 Long knobs must be positioned at 15. See **Fig. Index scale 43 x 15 cm**.

e.g., at SID 100 cm, to have an X-Ray field 35 cm (Cross) x 20 cm (Long), the Cross knob must be positioned on 35 and both the 2 Long knobs must be positioned on 20. See **Fig. Index scale 43 x 20 cm**

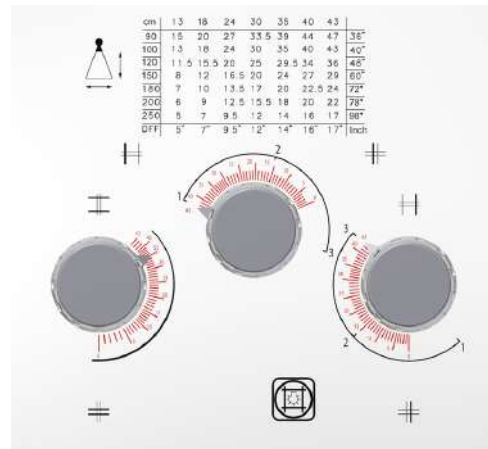

Fig. Index scale 35 x 43 cm

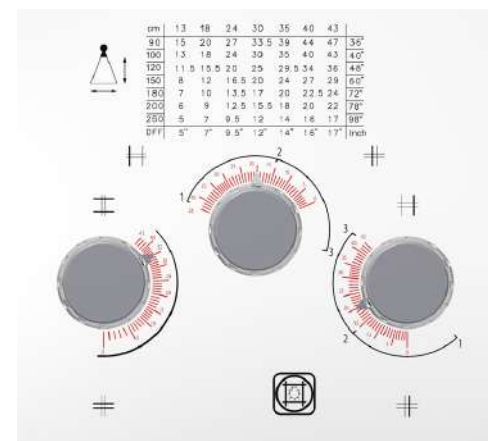

Fig. Index scale 43 x 15 cm

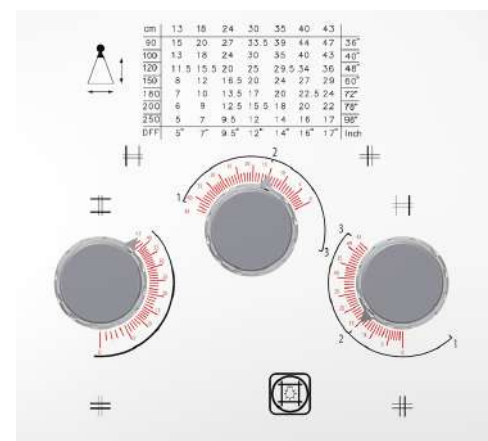

Fig. Index scale 43 x 20 cm

To use the collimator in stitching mode:

The maximum aperture of the X-Ray field is 43 x 43 cm at SID 100 cm.

The stitching mode can be used at different SID.

This mode permits to subdivide the X-Ray field in 3 sections and to make 3 exposures, one for each section.

To set the stitching mode at the desired SID, the Cross knob (the knob on the left) has to be positioned on the value of the scale in reference to the silk screen board on the front panel. The two Long knobs (the knob in the middle and the knob on the right) both have to be positioned on the setting 1, 2 or 3 indicated on the scale following the stitching desired field.

Field 1

Cross left knob - aperture 35 cm

Long central knob - position 1

Long right knob - position 1

See **Fig. Field 1**.

Field 2

Cross left knob - aperture 35 cm

Long central knob - position 2

Long right knob - position 2

See **Fig. Field 2**.

Field 3

Cross left knob - aperture 35 cm

Long central knob - position 3

Long right knob - position 3

See **Fig. Field 3**.

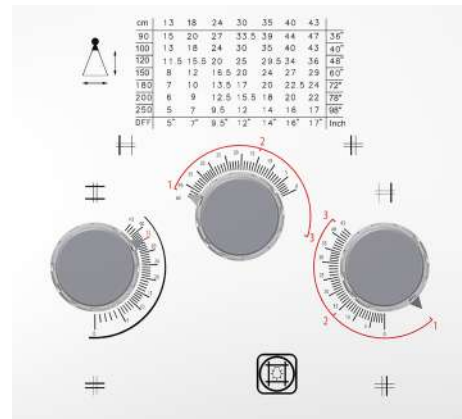

Fig. Field 1

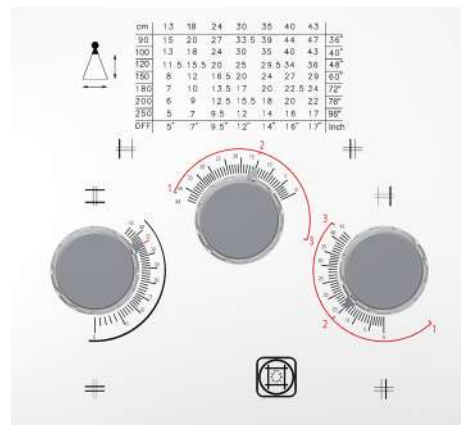

Fig. Field 2

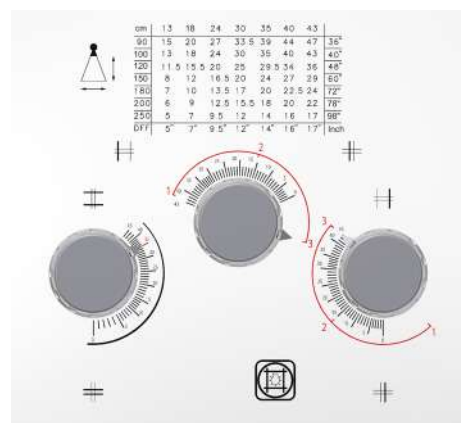

Fig. Field 3

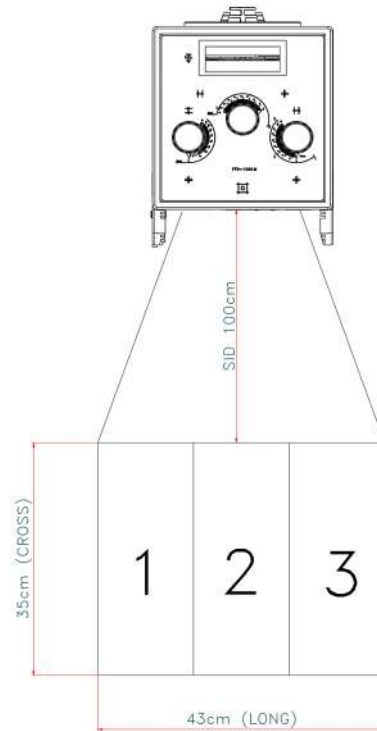
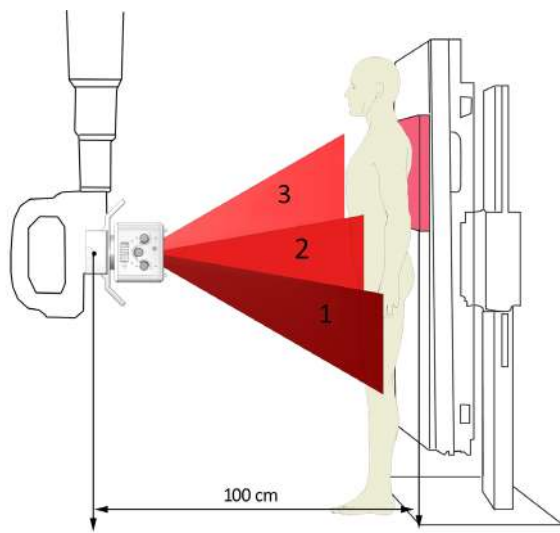

Fig. Stitching process

RO 456 Metal Rotating Mounting Flange

Metal rotating mounting flange:

- 20 mm thickness
- +/- 90° mechanical stop
- 136 mm diameter

Please refer to section **RO 492 Adjustable Top-Cover Bracket** in this chapter of the Instruction Manual for the correct flange/collimator mounting instructions.

This flange is **ONLY** available with **RO 492**.

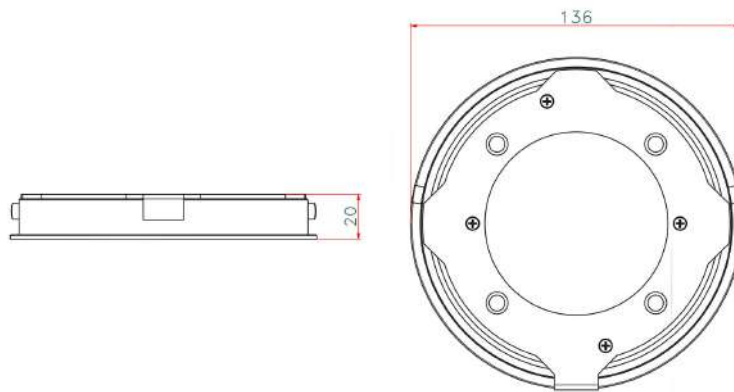

RO 489 Resin Rotating Mounting Flange

Resin rotating mounting flange:

- 20 mm thickness
- +/- 45° detent
- 140 mm diameter

Please refer to the chapter **INSTALLATION** in this Instruction Manual for the correct flange/collimator mounting instructions.

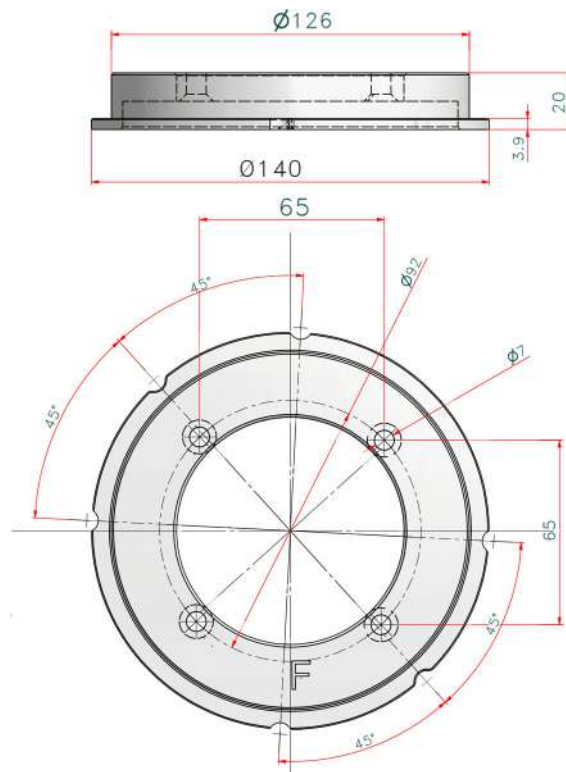

R225 - R225 DHHS - Optional Items

RO 492 Adjustable Top-Cover Bracket

This accessory has been designed to precisely install the collimator with a 136mm diameter metal flange (not included) to the X-ray tube.

WARNINGS



THE COLLIMATOR MUST BE INSTALLED TO THE X-RAY TUBE THROUGH A MOUNTING FLANGE. RALCO PROVIDES VARIOUS FLANGE OPTIONS WHICH MAY NOT BE INTERCHANGEABLE. ONLY FLANGES PROVIDED WITH THE COLLIMATOR MAY BE UTILIZED. THE END-USER MAY INSTALL THEIR OWN FLANGE, HOWEVER RALCO CANNOT GUARANTEE COMPATIBILITY. ANY PREEXISTING FLANGE ON THE END-USER SYSTEM MUST NOT BE USED.



WHEN A FLANGE IS PROVIDED WITH THE COLLIMATOR BEARING A MATCHING SERIAL NUMBER, ENSURE THEY ALWAYS REMAIN COUPLED. IT IS MANDATORY THEY REMAIN TOGETHER AND THE CORRECT FLANGE PART NUMBER IS USED.



THE CONTENTS OF THE INSTRUCTIONS BELOW SHOULD BE STRICTLY ADHERED TO. RALCO IS NOT LIABLE FOR ANY PROPERTY DAMAGE OR RESULTING HARM IF NON-RALCO COMPONENTS OR NON-COMPATIBLE RALCO COMPONENTS ARE USED DURING THE INSTALLATION PROCESS.

Installation

TUBE COMPATIBILITY

1. Using the dimensions in **Fig. Tube Compatibility** below, ensure the near port shutters of the collimator are placed in the X-Ray tube port without interference.

- The distance between the X-Ray tube focus and the flange mounting plane (collimator upper plate) must be: 80 mm (3.14"), tolerance +/- 1 mm (0.04 ").

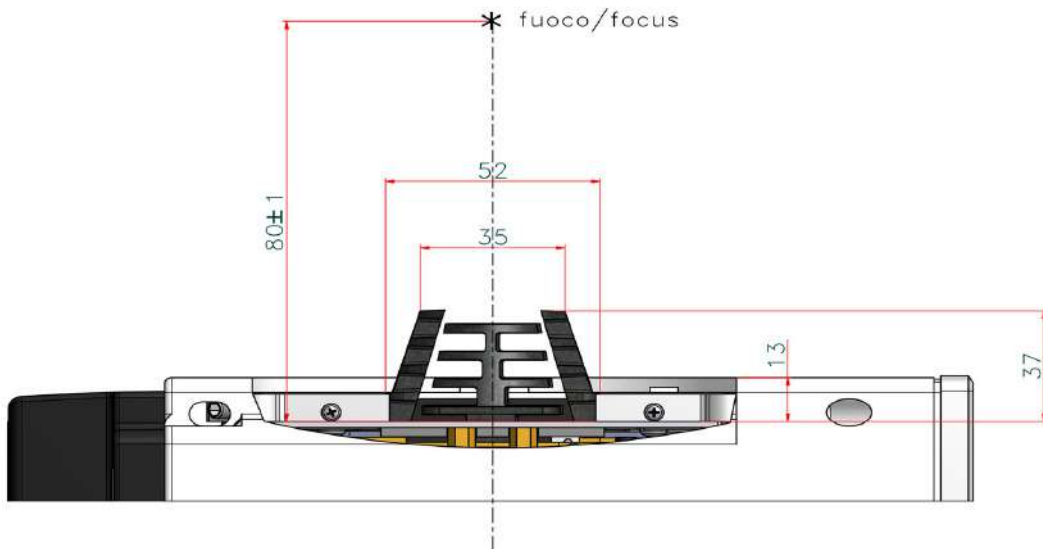

Fig. Tube Compatibility

- Carefully remove the collimator and the mounting flange (if purchased) from their packaging.
- Use the X-Ray tube housing datasheet to determine the distance (**A**) from the focal spot to the X-Ray tube port, see **Fig. Collimator Installation**.
- Subtract the resulting distance from the source flange distance (**B**) and determine the number of spacers (1.5 mm) which, combined with the thickness of the mounting flange, will make up the difference (**C**). Allowable tolerance is 1 mm. (0.04"), see **Fig. Collimator Installation**.
- Once the mounting plane distance has been confirmed, continue with the mounting flange installation to the X-Ray tube.

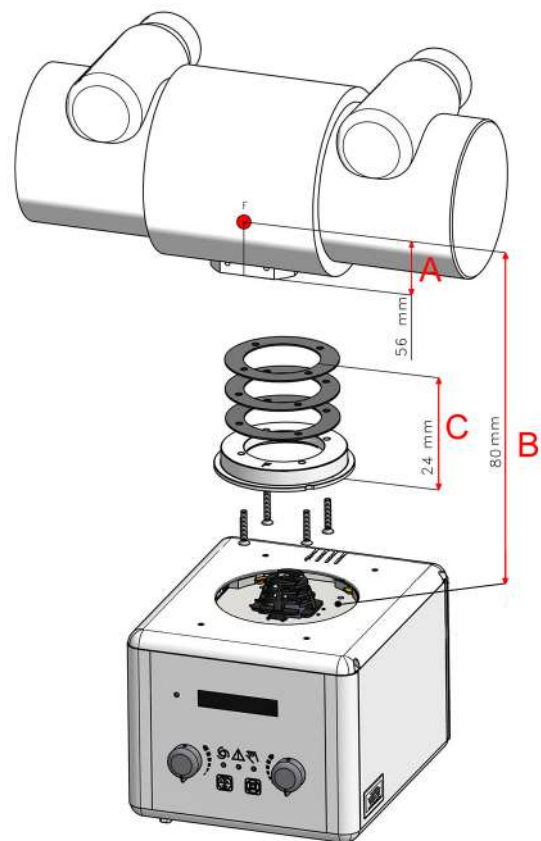

Fig. Collimator Installation
*illustrative purpose only

**The flange fixing screws and the spacers of the previous flange may be reused if the flange thickness is the same.*

Mounting the Flange to the X-ray Tube

NOTE



THE FOLLOWING MOUNTING INSTRUCTIONS ARE ONLY APPLICABLE FOR COMPATIBLE FLANGES WITH THIS OPTIONAL ITEM. IF YOU ARE UNSURE THE MOUNTING FLANGE YOUR COLLIMATOR IS EQUIPPED WITH IS COMPATIBLE, PLEASE CONSULT YOUR PERSONALIZATION PAGE PROVIDED WITH THIS MANUAL TO LOCATE THE FLANGE PART NUMBER (RO REFERENCE). FOLLOW THE MOUNTING INSTRUCTIONS SET FORTH UNDER THE SPECIFIC RO REFERENCE IN THIS MANUAL.

WARNING



FLANGES MAY BE PROVIDED BY RALCO OR BY THE SYSTEM MANUFACTURER. FLANGES MAY NOT BE INTERCHANGEABLE. ONLY THE FLANGE PROVIDED WITH THE COLLIMATOR BEING INSTALLED WITH A SPECIFIC PART CODE MAY BE UTILIZED. ANY PRE-EXISTING FLANGES MAY NOT TO BE USED. IF THERE ARE ANY QUESTIONS REGARDING COMPATIBILITY, PLEASE CONTACT RALCO.

CAUTION



RALCO CANNOT GUARANTEE COMPLIANCE WITH RADIATION STANDARDS CONCERNING SAFETY IF THIS CONTROL HAS BEEN OMITTED.

1. Place the flange on the X-Ray tube port, see **Fig. Flange Installation**.
2. Mount the mounting flange and spacers (optional) to the X-Ray tube port using 4 screws.**

****Please ensure no conflicting information nor dangerous conditions exist due to adhering to these instructions or those provided by the X-Ray tube manufacturer. When in doubt please contact X-ray tube manufacturer and/or Ralco.**

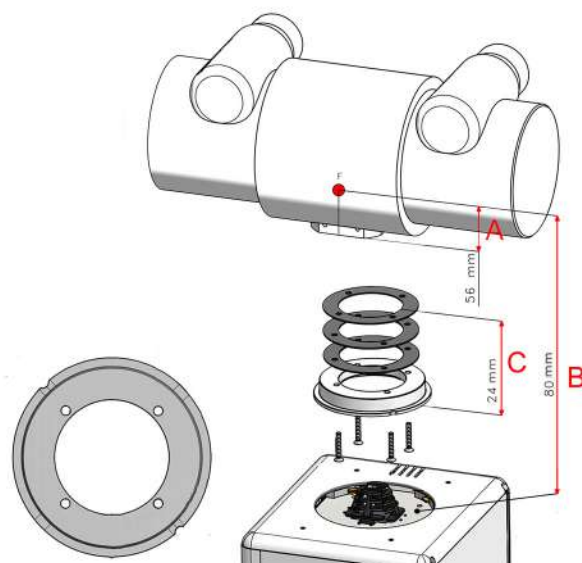

Fig. Flange Installation
**illustrative purpose only*

R225 - R225 DHHS - Optional Items

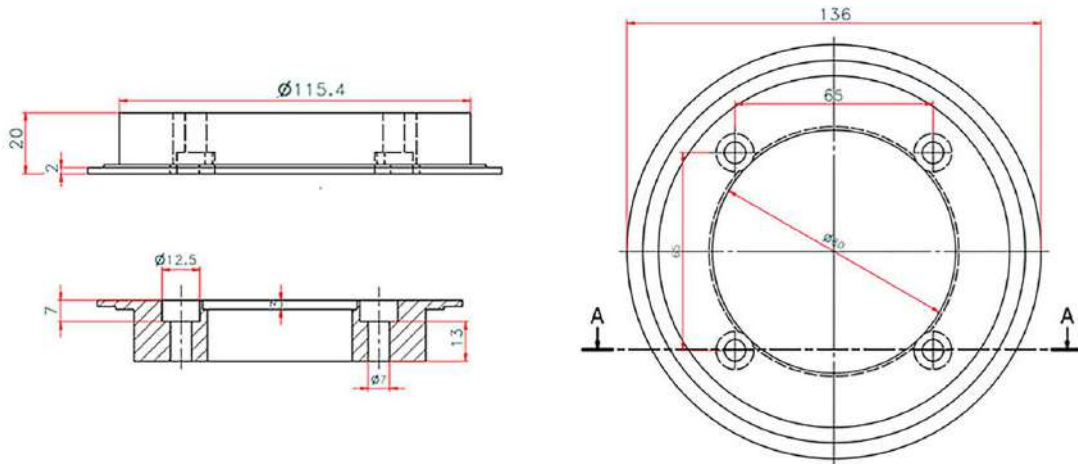

Fig. Mounting Flange
**illustrative purpose only*

CAUTION



ENSURE THE SCREW HEAD IS INDEED CORRECT FOR THE FLANGE SELECTED. IT IS THE RESPONSIBILITY OF THE END-USER TO ENSURE ALL SAFETY MEASURES ARE IMPLEMENTED TO ENSURE THE SCREWS ARE OPTIMALLY TIGHTENED INCLUDING THE USE OF APPROPRIATE LOCKTITE.



TIGHTEN THE 4 SCREWS TO THE X-RAY TUBE HEAD SECURELY, STRICTLY ACCORDING TO THE INSTRUCTIONS OF THE X-RAY TUBE MANUFACTURER. DO NOT EXCEED 0.45 NM OF FORCE.

Alignment of X-Ray Tube Focus and Collimator

Ralco guarantees the correct collimator functionality, format compliance and light/X-Ray field alignment only if the mounting flange and the collimator have been installed exactly in the centre of the X-Ray beam.

All Ralco collimators are aligned on our test bench utilizing specific references/values for our X-Ray tube focus, detector and Source to Image Detector Distance (SID). The customer must know and verify all known variables which may influence the X-Ray tube focus and collimator alignment. These may include, the X-Ray tube focus position tolerance, distance from X-Ray tube focus to collimator mounting plane, or the SID.

Alignment Device

This device is used to ensure the collimator mounting flange is correctly aligned to the X-ray beam. The X-ray tube manufacturer provides a tolerance for the placement of X-ray tube focus.

Ralco recommends to use the Focal Alignment Device (jig) to ensure the correct flange alignment with the centre of the X-Ray beam, see **Fig. Focal Alignment Device**. By making an exposure, it is possible to verify the perpendicularity and concentricity using fixed references on the X-Ray image.

Once the mounting flange is aligned the collimator light/X-ray field should also be aligned (within specific tolerances).

Please consult the technical specifications of your X-Ray tube to find the maximum tolerance for the position of the focus. Should the use of an alignment device not be possible, Ralco collimators allow for the regulation of the light field.

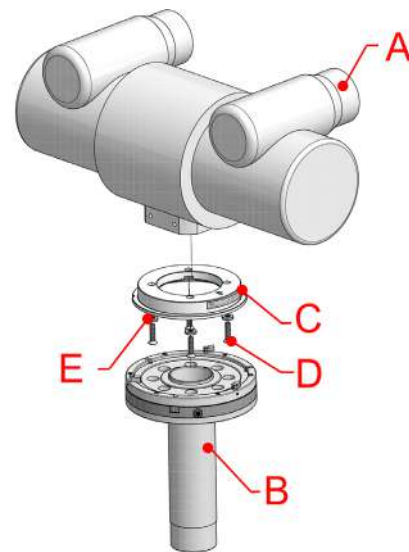

A - X-Ray Tube, B - Focal Adjustment Device
C - Mounting Flange, D - Screw, E - Washer

Fig. Focal Alignment Device

Mounting the Collimator to the Flange

NOTE



THE MOUNTING FLANGE PROVIDED (IF PURCHASED) WITH THE COLLIMATOR IS SUBJECTED TO TESTING PURSUANT TO ALL APPLICABLE STANDARDS.



MOUNTING BRACKET TABS CONFORM TO EN60601.

WARNINGS



PURSUANT TO APPLICABLE STANDARDS, RALCO HAS TESTED THE COLLIMATOR AND FLANGE APPLYING STATIC LOADS. RALCO IS NOT IN A POSITION TO KNOW THE DYNAMIC FORCES OF ALL END-USER SYSTEMS. IT IS THE RESPONSIBILITY OF THE END-USER TO ENSURE DYNAMIC FORCES OF THE SYSTEM DO NOT CREATE A DANGEROUS CONDITION.



IT IS THE RESPONSIBILITY OF THE SYSTEM MANUFACTURER TO ENSURE AND MITIGATE ANY DANGEROUS CONDITIONS WHICH MAY OCCUR DUE TO THE DYNAMIC FORCES CREATED BY THE SYSTEM. THE END-USER MUST PERFORM A SYSTEMATIC AND STRUCTURAL ANALYSIS DURING THE INSTALLATION AND USUAL MAINTENANCE.



SHOULD ANY DAMAGE TO THE COLLIMATOR OR FLANGE OCCUR A RISK ANALYSIS AND DAMAGE ASSESSMENT NEEDS TO BE CONDUCTED IMMEDIATELY. CONTACT RALCO IMMEDIATELY SHOULD THIS OCCUR. RALCO IS NOT LIABLE FOR RESULTING PROPERTY DAMAGE AND/OR HARM DUE TO AN UNREPORTED INCIDENT.



RALCO HAS DESIGNED AND TESTED THE COLLIMATOR FOR A LIFETIME OF 10 YEARS. AFTER THIS TIME PERIOD, IT IS THE RESPONSIBILITY OF THE END-USER TO ENSURE THE PROPER FUNCTIONING OF THE COLLIMATOR AND FLANGE. LIABILITY FOR ANY DANGEROUS CONDITIONS WHICH MAY BE PRESENT AFTER THE 10YEAR LIFETIME OF THE COLLIMATOR AND FLANGE RESTS WITH THE END-USER.



TO ENSURE THE SAFETY OF THE COLLIMATOR AND FLANGE AFTER 10 YEARS OF USE, RALCO HAS INSTITUTED A PROGRAM TO ASSESS THE SAFETY OF THE COLLIMATOR AND FLANGE. AFTER APPLYING A CHECK LIST OF QUALITY CONTROLS AND REFURBISHMENT ACTIVITIES (AT END-USER EXPENSE), RALCO MAY CERTIFY THE COLLIMATOR AND FLANGE FOR ADDITIONAL YEARS OF USE.

1. Prepare the collimator to be installed by unscrewing the 4 hexagonal socket screws until the four tabs are completely withdrawn from the collimator top mounting plane, see **Fig. 4 Mounting Screws**.
2. If installing a manual collimator, adjust the collimator shutters to the fully open position using both knobs.

CAUTION



WHEN UNSCREWING THE HEXAGONAL SOCKET SCREW WHICH CONTROL THE TABS, DO NOT USE FORCE EXCEEDING 0,45 NM. UNSCREW WITH CARE SO AS NOT TO DAMAGE THE HEXAGONAL SCREW HEAD AND TABS.

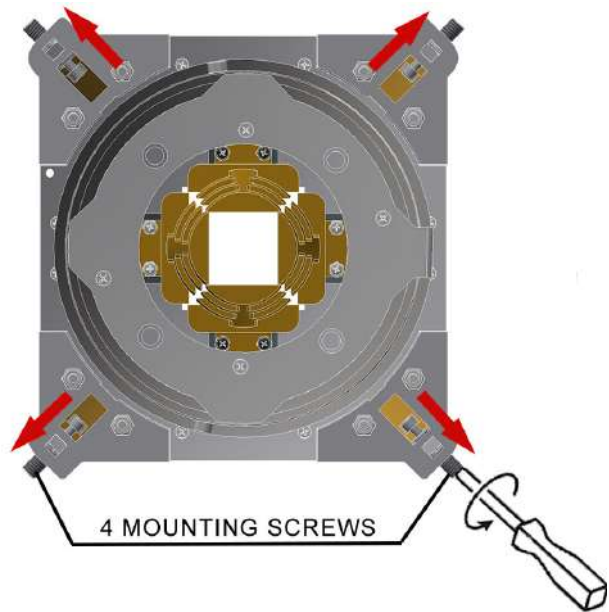

Fig. 4 Mounting Screws

3. With the tabs fully retracted, the hexagonal socket screws of the mounting bracket must be tightening equally up to the end stroke with 0.45 Nm torque (at least 7 turns), see **Fig. Mounting Bracket**.
4. The 4 tabs of the hexagonal socket screws overlap on the flange outer ring in the same manner.
5. The collimator tabs adhere to the flange outer ring. Depending on the optional flange purchased, the collimator may rotate or be fixed (no rotation).
6. Once the collimator is coupled to the flange in the method described above, verify the distance between the collimator housing and the mounting flange is equal in all directions and the collimator face is parallel to the axis of the table. Loosen the screws and adjust as necessary.
7. The collimator should be coupled to the flange firmly. If the collimator is loose, please repeat the above mounting instructions, and if issues persist, please contact Ralco.

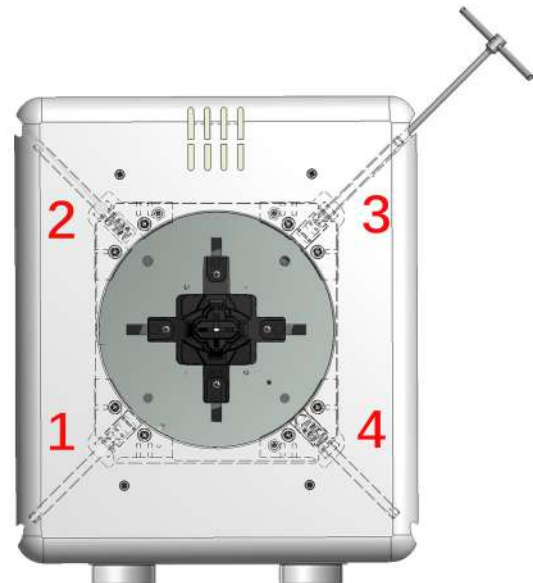

Fig. Mounting Bracket
**illustrative purpose only*

Verification of Correct Installation

WARNING



IT IS THE DUTY OF THE INSTALLER TO ENSURE NO RISK OF THE COLLIMATOR FALLING EXISTS. ENSURE THE FOLLOWING, AS IN EACH SCENARIO BELOW SERIOUS RISK OF INJURY AND/OR PROPERTY DAMAGE MAY EXIST DUE TO NON-ADHERENCE.

1. The 4 tabs should overlap the flange outer ring, see **Fig. Correct Overlap**.
2. Ensure the mounting flange is flat against the collimator mounting plane, see **Fig. Correct Overlap**.
3. Ensure the 4 tabs are not in contact with only the mounting flange edge, see **Fig. Incorrect Overlap**.
4. Once the collimator is mounted, if not already, return the collimator/tube head to the intended use position. Rotate and/or gently pull the collimator to ensure correct coupling.
5. If the collimator is loose, something is incorrect. Repeat above mounting instructions, and if issues persist, please contact Ralco.

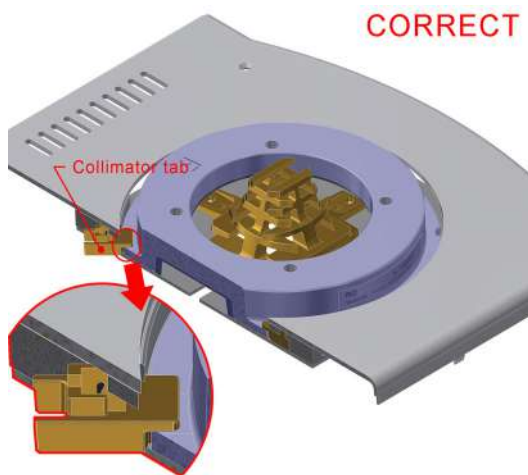

Fig. Correct Overlap



Fig. Incorrect Overlap

RO 495 Camera assembled internally for patient monitoring

An IP ethernet interface is a type of digital camera commonly employed for surveillance, and which, unlike analog closed circuit television (CCTV) cameras, can send and receive data via a computer network and the Internet.

RO 525 Customized Knob design

The customer can specify the knob design.

RO 530 Resin Rotating Mounting Flange

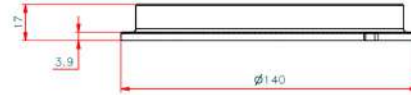

Resin rotating mounting flange:

- 17 mm thickness
- 0° detent
- 140 mm diameter

Please refer to the chapter **INSTALLATION** in this Instruction Manual for the correct flange/collimator mounting instructions.

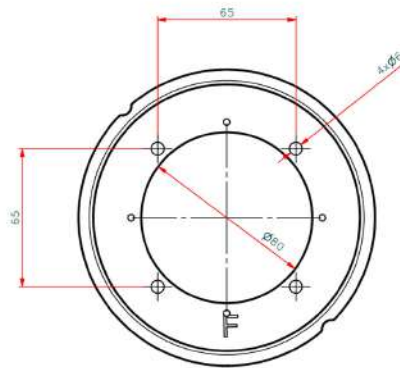

RO 586 Single Laser Line Projection

The collimator laser is classified as Class 1 (1 m W - wavelength = 645 nm, +/- 10 nm); used for collimator/image receptor center alignment, see **Fig. Laser Line**.

WARNINGS



CAUTION: CLASS 1 LASER SYSTEM DO NOT STARE INTO THE BEAM.

Laser Adjustment

- Remove part of the cover to access the point of adjustment, see Chapter- **COVER REMOVAL**.
- The line is to fall on a perpendicular cross-line on the plastic anti-dust panel near the collimator controls, see **Fig. Laser Line**.
- Adjust the position of the line by rotating or moving the base of the laser system.
 - To rotate the laser system, loosen the Allen screw **A**, see **Fig. Laser Adjustment**.
 - Tighten the Allen screw when the laser beam falls on or is parallel to the bisector line drawn on the anti-dust panel.
- Shift the laser system by loosening the two **B** screws holding the laser system base to the beam limiting device front plate.
 - Move the base until the laser beam falls over the perpendicular bisector line on the anti-dust panel, see **Fig. Laser Alignment**.
 - Tighten the two **B** screws.

WARNINGS



DO NOT APPLY EXCESSIVE FORCE TO THE SCREW. THE LASER SHELL IS IN PLASTIC AND EXCESSIVE PRESSURE COULD CRACK THE PLASTIC AND POSSIBLY SHORT-CIRCUIT THE LASER.

Fig. Laser Line

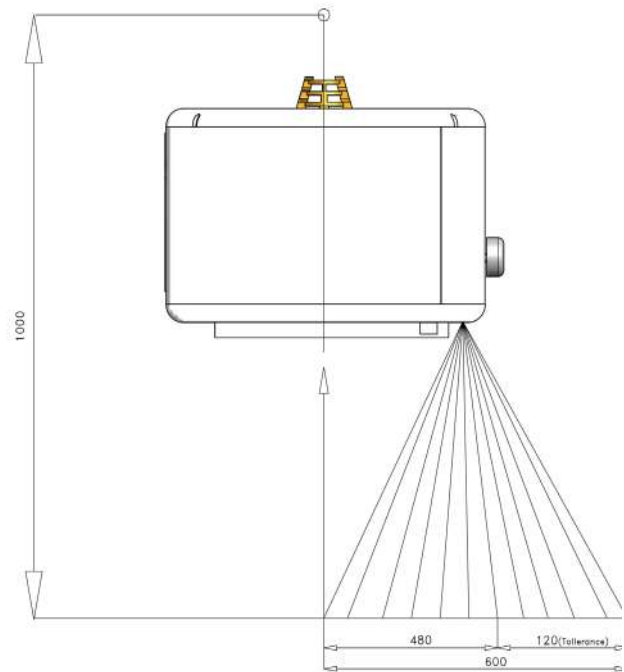

Fig. Laser Adjustment

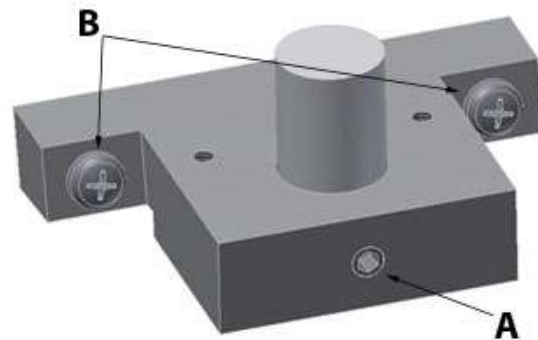
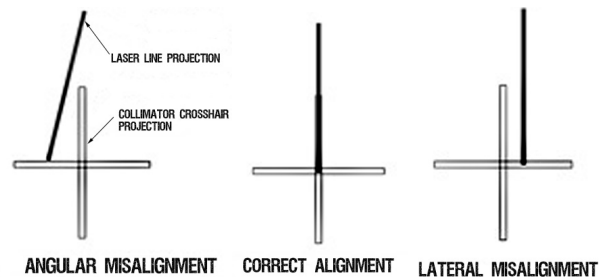

Fig. Laser Alignment



R225 - R225 DHHS - Optional Items

Substitution

The Laser Substitution Kit is composed of the following components: the laser (A), the extension cable (B) and the laser label (C) pictured below in **Fig. Laser Substitution Kit**. This Kit is designed to substitute any laser Ralco provides.

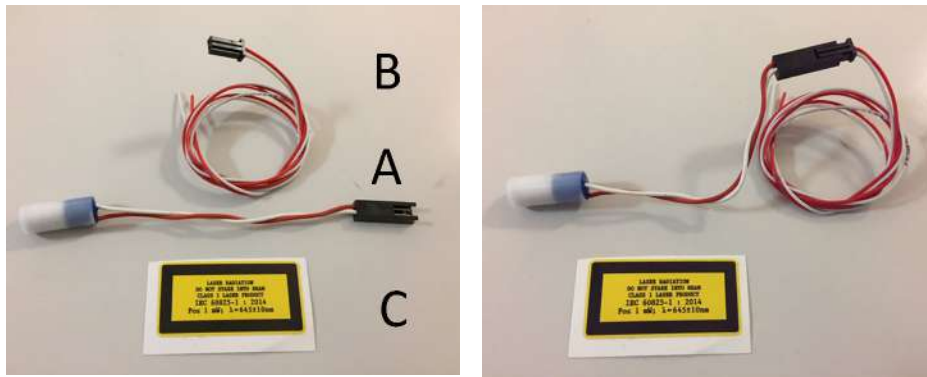

Fig. Laser Substitution Kit

Prior to replacing the laser, confirm which version of laser is installed on your collimator which will ensure the substitution is performed correctly.

- The previous laser version is connected to the board via 2 cables (red and white), see **Fig. Previous Laser Version** below.

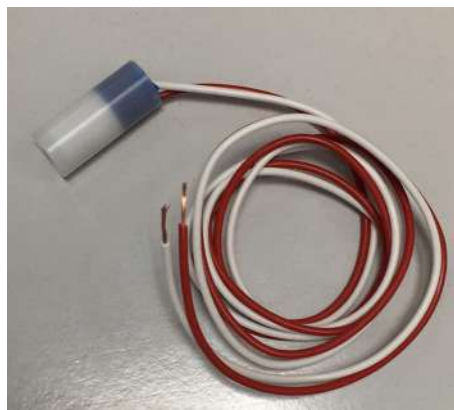

Fig. Previous Laser Version

- The new laser is connected to the board via the connector, see **Fig. New Laser Version** below..



Fig. New Laser Version

Replacing the Previous Laser Version

To replace the previous version of laser, all components of the Laser Substitution Kit (A, B and C) must be used.

R225 - R225 DHHS - Optional Items

To substitute the laser, proceed as follows:

6. Disconnect the collimator supply.
7. Remove the cover, see Chapter **COVER REMOVAL** in the Instruction Manual for your specific model.
8. Prior to disconnecting the laser cables from the board, identify the cables and their position on the terminal board, see Chapter **INSTALLATION**, paragraph **Wiring Diagram** in the Instruction Manual for your specific model.
9. Carefully remove the laser, the extension cable and the label from their packaging.
10. Ensure the extension cable (**B**) is firmly connected to the laser (**A**), see **Fig. Laser Substitution Kit** above.
11. Substitute the laser with the identical item using component (**A**) of the Laser Substitution Kit, see **Fig. Laser Substitution Kit** above.
12. Adjust the length of the extension (**B**) cable by cutting the 2 cables (red/white).
13. Connect both cables to the board.
14. Apply the new laser label (**C**) to the collimator cover, see Chapter **SPARE PARTS** in the Instruction Manual for your specific mode.
15. Verify the Laser alignment, see Chapter **ADJUSTMENT** or **OPTIONAL ITEMS** in the Instruction Manual for your specific model.

Replacing the New Laser Version

To replace the new laser version, only part **A** and **C** of the Kit must be used.

To substitute the laser, proceed as follows:

- Disconnect the collimator supply.
- Remove the cover, see Chapter **COVER REMOVAL** in the Instruction Manual for your specific model.
- Detach the connector of the faulty laser from the collimator wiring.
- Carefully remove the laser, the extension cable and the label from their packaging.
- Substitute the laser with the identical item using component (**A**) of the Laser Substitution Kit, see **Fig. Laser Substitution Kit** above.
- Connect the new laser to the collimator wiring.
- Apply the new laser label (**C**) to the collimator cover, see Chapter **SPARE PARTS** in the Instruction Manual for your specific mode.
- Verify the Laser alignment, see Chapter **ADJUSTMENT** or **OPTIONAL ITEM** in the Instruction Manual for your specific model.

Classification EN 60825-1 par. 1 -5: Class 1 laser product => Red laser line.

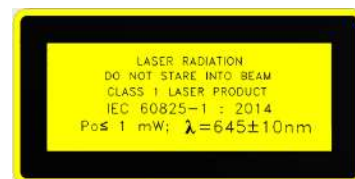

RO 587/2 Two lasers forming a crosshair to center the patient to the collimator: Class 1

Second laser which serves to center the patient using the cross projection.

The collimator lasers are classified as Class 1 (1 m W - wavelength = 645 nm, +/- 10 nm) and are used for collimator/image receptor center alignment.

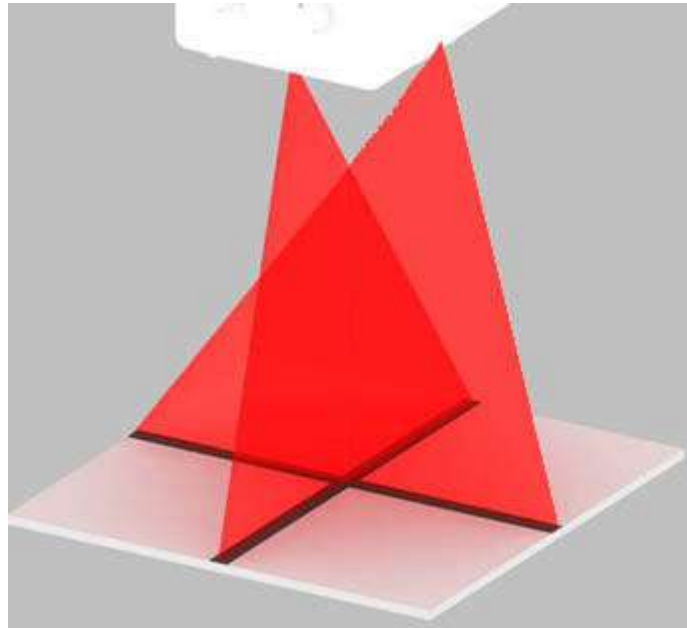

CAUTION: CLASS 1 LASER SYSTEM DO NOT STARE INTO THE BEAM.

CALIBRATION CONTROL

- Draw a cross (two lines at 90°) on a sheet of paper and use this as reference.
- Switch the light ON and set the sheet of paper at 1 m from the focus.
- Make sure the cross on the paper coincides exactly with the two lines silk-screened on the plastic window.
- Examine the laser projections on the paper: the laser is correctly calibrated when the projections coincide with the lines drawn on the paper, otherwise an adjustment will be necessary.

ADJUSTMENT

Horizontal

- Disconnect the collimator supply.
- Remove the laser cover located on the collimator cover by unscrewing the two screws **A**, see **Fig. Horizontal Laser**.
- To correct horizontal misalignment, loosen the screws **B**, see **Fig. Horizontal Laser** and move the laser support until the projected laser line coincides with the cross on the sheet of paper. Tighten screws **B**.

Vertical

- Disconnect power supply.
- Remove the knobs and front panel, see Chapter- **COVER REMOVAL**.
- To correct vertical misalignment, loosen the Allen screw **A**, see **Fig. Vertical Laser** on the laser support; rotate the laser and align the laser line over the cross on the sheet of paper.
- To move laterally the laser loosen the screws **B** and shift the laser support until the projected laser line coincides with the cross on the sheet of paper.
- Tighten **B** screw s.

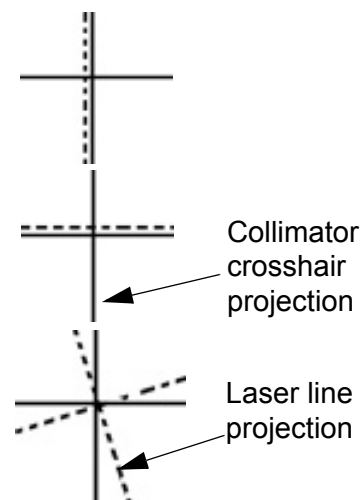

Fig. Laser Projections

WARNINGS



DO NOT APPLY EXCESSIVE FORCE TO THE SCREW. THE LASER SHELL IS IN PLASTIC AND EXCESSIVE PRESSURE COULD CRACK THE PLASTIC AND POSSIBLY SHORT-CIRCUIT THE LASER.

SUBSTITUTION

The Laser Substitution Kit is composed of the following components: the lase (**A**), the extension cable (**B**) and the laser label (**C**) pictured below in **Fig. Laser Substitution Kit**. This Kit is designed to substitute any laser Ralco provides.

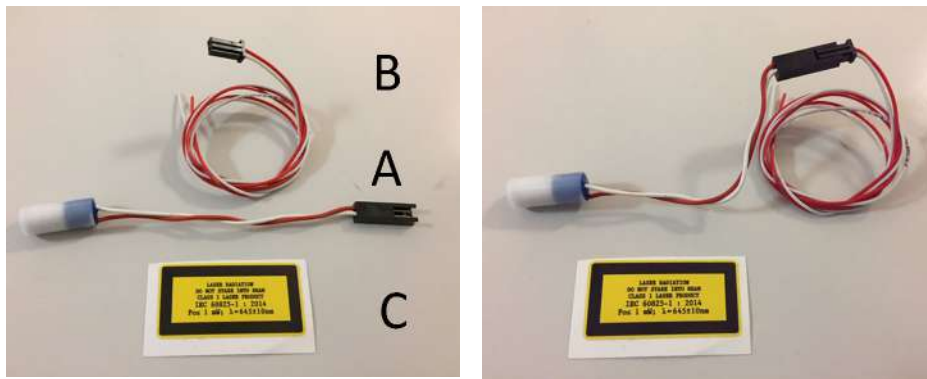

Fig. Laser Substitution Kit

Prior to replacing the laser, confirm which version of laser is installed on your collimator which will ensure the substitution is performed correctly.

- The previous laser version is connected to the board via 2 cables (red and white), see **Fig. Previous Laser Version** below.

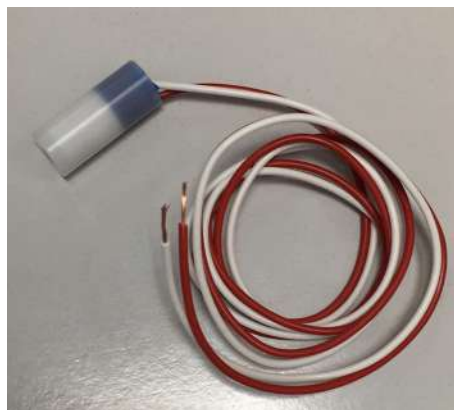

Fig. Previous Laser Version

- The new laser is connected to the board via the connector, see **Fig. New Laser Version** below.

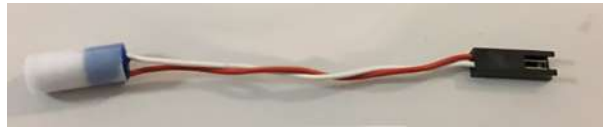

Fig. New Laser Version

Replacing the Previous Laser Version

To replace the previous version of laser, all components of the Laser Substitution Kit (RS 2589) (A, B and C) must be used.

To substitute the laser, proceed as follows:

16. Disconnect the collimator supply.
17. Remove the cover, see Chapter **COVER REMOVAL** in the Instruction Manual for your specific model.
18. Prior to disconnecting the laser cables from the board, identify the cables and their position on the terminal board, see Chapter **INSTALLATION**, paragraph **Wiring Diagram** in the Instruction Manual for your specific model.
19. Carefully remove the laser, the extension cable and the label from their packaging.
20. Ensure the extension cable (**B**) is firmly connected to the laser (**A**), see **Fig. Laser Substitution Kit** above.
21. Substitute the laser with the identical item using component (**A**) of the Laser Substitution Kit, see **Fig. Laser Substitution Kit** above.
22. Adjust the length of the extension (**B**) cable by cutting the 2 cables (red/white).
23. Connect both cables to the board.
24. Apply the new laser label (**C**) to the collimator cover, see Chapter **SPARE PARTS** in the Instruction Manual for your specific mode.
25. Verify the Laser alignment, see Chapter **ADJUSTMENT** or **OPTIONAL ITEMS** in the Instruction Manual for your specific model.

Replacing the New Laser Version

To replace the new laser version, only part **A** and **C** of the Kit must be used.

To substitute the laser, proceed as follows:

- Disconnect the collimator supply.
- Remove the cover, see Chapter **COVER REMOVAL** in the Instruction Manual for your specific model.
- Detach the connector of the faulty laser from the collimator wiring.
- Carefully remove the laser, the extension cable and the label from their packaging.
- Substitute the laser with the identical item using component (**A**) of the Laser Substitution Kit, see **Fig. Laser Substitution Kit** above.
- Connect the new laser to the collimator wiring.
- Apply the new laser label (**C**) to the collimator cover, see Chapter **SPARE PARTS** in the Instruction Manual for your specific mode.
- Verify the Laser alignment, see Chapter **ADJUSTMENT** or **OPTIONAL ITEM** in the Instruction Manual for your specific model.

Classification EN 60825-1 par. 1 -5: Class 1 laser product => Red laser line.



MAINTENANCE

To ensure constantly safe performance of the collimator and its compliance with applicable regulations, a maintenance program is indispensable.

It is the Owner's responsibility to supply or arrange for this service.

CLEANING RECOMMENDATIONS

- The collimator housing must be cleaned as prescribed by the sanitary regulations followed by the operator.
- Disconnect supply.
- Use non abrasive cleaning products.
Care must be taken to prevent liquid from entering the collimator. **Please Note: The collimator cover is not watertight.**
- **Do not** reapply power if inflammable liquids have leaked into the collimator. See the following Maintenance Instructions.
- Clean the varnished and aluminium surfaces with a damp cloth only, using a neutral cleansing agent then dry the surfaces with a soft cloth.
- Clean chrome surfaces with a dry soft cloth.

CAUTION



DO NOT SPRAY WATER OR DETERGENT DIRECTLY OVER THE COLLIMATOR. THE UNIT'S LIQUID PROTECTION LEVEL IS IPX0.

DISINFECTION

The disinfection method use must conform with the currently applicable norms and directives covering disinfection and protection against explosion hazards.

CAUTION



NEVER USE CAUSTIC SUBSTANCES, SOLVENTS OR ABRASIVE DETERGENTS. IF PRODUCTS THAT COULD FORM EXPLOSIVE GAS MIXTURES ARE USED, ALLOW THE GAS TO EVAPORATE BEFORE STARTING THE SYSTEM.

- Disconnect supply.
- Disinfect the unit including accessories and cables with a dampened cloth.
- Do not spray the unit with the disinfectant because it could leak into the collimator.

RECOMMENDED MAINTENANCE PROGRAM

Ralco suggests a yearly servicing program, however shorter intervals are advisable when the collimator is subject to heavy workloads.

- Re-calibration of the collimator will be necessary whenever the X-ray tube is changed or at each substitution of the source light (lamp or LED, if assembled) used to simulate the light field.

- Calibration procedures (if provided) must be performed as described in this manual.
- Check once a week that the screws and tabs which serve to secure the collimator to the flange/tube adapter are correctly tightened.
- Remove the covers and panels from collimator. Inspect the moving parts for signs of wear or damage.
- Check the electric system and substitute parts that show wear.
- Check the plastic anti-dust window and substitute it if necessary.
- Clean the collimator with a soft cloth paying particular attention to the plastic anti-dust window. Do not use abrasive or inflammable cleaning products.
- Wipe away all excess oil and remount the cover.

CAUTION



MAKE SURE TO TIGHTEN THE ALLEN SCREWS SECURING THE COLLIMATOR OR THE CONTROL TABS.
APPROPRIATE TIGHTENING OF THE 4 ALLEN SCREWS ENSURES SECURE MOUNTING OF THE COLLIMATOR. TIGHTENING FORCE USED MUST NOT EXCEED 0.50 NM.

NOTE



IF THE COLLIMATOR IS TO BE MOUNTED ON A ROTATING FLANGE, USE A TIGHTENING FORCE BETWEEN MIN. 0,50 NM AND MAX. 0.75 NM.

GENERAL

WARRANTY

This product has been manufactured and tested to the highest quality standards by Ralco, srl. Ralco undertakes to replace and repair any collimator during a period of 24 months for mechanical and 12 months for electrical parts (motors, potentiometers, electrical boards, lasers) from the date of invoice (shipment date from Ralco).

The warranty applies provided the product has been handled properly in accordance with its operating instructions and its intended use.

Warranty covers cost of all components and labor involved, **unless**:

- Product documents have been altered in any way or made illegible;
- The model or production number on the product has been altered, deleted, removed or made illegible;
- Repairs or product modifications and alterations have been performed by unauthorized and unqualified persons;
- Unauthorized repairs and/or modifications have been performed;
- Damage caused by misuse or neglect, incorrect installation or accidental damage;
- Damage occurred during transit due to shipping company, or incorrect packing by customer;
- Unoriginal spare parts and accessories have been used.

In-warranty spares will be available only upon return to Ralco, at the customer's expense, of the parts considered to be faulty to allow Ralco to assess the cause of the fault.

Components Not Covered by this Warranty:

- Consumable items such as lamp bulbs, lexan panels and mirrors (if applicable);
- Cosmetic damage such as scratches;
- Any missing components when product arrives for repair.

REPAIRS

In the event the customer finds any Non Conformity in the product, please contact Ralco via e-mail at the address: repairs@ralco.it (Ralco Repair Assistance).

To successfully resolve any Non Conformity, the following information must be provided:

- The model and serial number of the collimator found on the label;
- A detailed description of the problem (in Italian or English);
- Whether you want a repair, refurbishment, or model upgrade of the product.

Ralco and the customer will work together to resolve the problem by either providing instructions, and/or field service or by sending replacement parts.

In the event the collimator needs to be repaired at Ralco, you will be provided with a RMA (Return Merchandise Authorization) number as your consent to the return. If a product is returned to Ralco without a RMA or without a description of the problem, the customer will incur a €100 processing fee.

If the product is returned under warranty and no defect is found, the customer incurs the cost of evaluation, testing and shipping.

The shipping of the unit is at the customer's expense if the unit is out of warranty.

The warranty period resets only on replaced parts once repairs are completed (shipment date from Ralco back to customer), see paragraph, **WARRANTY**.

Ralco reserves the right to decide if the product is to be repaired or substituted.

Please send defective material to the following address:

RALCO SRL
VIA DEI TIGLI 13/G
20853 BIASSONO (MB) - ITALIA
FAX: ++39-039-2497.799
EMAIL: RALCO@RALCO.IT

END OF LIFE DISPOSAL

Your collimator contains materials which can be recycled and reused. Specialised companies can recycle your product to increase the amount of reusable materials and to minimize the amount of materials to be disposed of.

The product contains lead which can be highly contaminating if dispersed incorrectly. The following symbol signifies that the product conforms to the environmental requirements of directives 202/95/EC, 2002/96/EC, 2003/108/EC; it must be disposed of correctly at the end of its life-cycle.



The collimator does not contain polluting materials or products with the exception of the lead that composes the shutters - avoid direct contact with lead especially for prolonged periods.

It is required that you observe Local Laws regulating the disposal of the collimator using certified environmental management entities. Should this prove impossible, return the collimator to Ralco at the purchaser's expense and Ralco will undertake its correct disposal.

If you are replacing the unit with new equipment, you may return the old collimator to Ralco. Please contact us if you require further information.

DISASSEMBLY

WARNINGS



CARE MUST BE TAKEN NOT TO LET THE COLLIMATOR FALL.

- Disconnect supply to the collimator.
- Remove the cover and disconnect the supply cables.
- Loosen the fixing Allen screws on the upper part of the collimator connected to the flange mounted to the X-ray tube.

TRANSPORT AND STORAGE

ATTENZIONE



ANY DAMAGE TO THE COLLIMATOR DUE TO INCORRECT OR UNSUITABLE PACKAGING IS THE RESPONSIBILITY OF THE CUSTOMER. IF POSSIBLE, THE USE OF ORIGINAL RALCO PACKAGING IS RECOMMENDED. IF THIS IS NOT POSSIBLE, PLEASE FOLLOW THE INSTRUCTIONS PROVIDED WITHIN THE INSTRUCTION MANUAL. IF THE COLLIMATOR IS NOT PACKAGED CORRECTLY, ALL WARRANTIES WILL BE VOIDED.

In order to properly package the collimator for shipping the following materials are needed:

- Plastic bag;
- Sturdy cardboard box properly sized for the collimator;
- Protective packaging (bubble wrap, bubble bags, air pillows, polyfoam etc.) -
- Packaging tape;
- Strapping.

Procedure:

1. Ensure all covers are remounted properly on the collimator if previously removed.
2. Place the collimator in the plastic bag to avoid packing material from entering the collimator.
3. Place the collimator inside the cardboard box.
4. Use protective packaging to fill any empty spaces inside the cardboard box so that the collimator is stable during shipment.
5. Seal the cardboard box firmly so it will not open during shipping using high-quality packaging tape.
6. Use strapping to ensure proper closure.
7. It is strongly recommended to pallet the packaging (especially when single collimators are shipped) to ensure proper handling.
8. Ensure of the correct storage conditions:
 - Ambient Temperature = from -40°C to +70°C
 - Relative Humidity = from 10% to 95%
 - Atm. Pressure = from 500 a 1060 hPa.

FRAGILE

X-RAY EQUIPMENT

DISPOSITIVO RADIOLOGICO - X射线设备

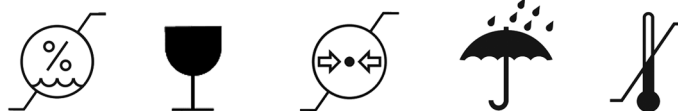

SAFETY/RESPONSIBILITY

Ralco adheres to the directives governing manufacturers of electro-medical equipment:

Directive 2007/47/CE para.10 -Legislative Decree n° 46 para.10

Ralco shall not be held responsible when instructions provided in the present manual are not complied with. Ralco shall not be held responsible if the collimator relates to one or several of the following instances:

- The unit is of Ralco construction, built to client specifications with no CE marking.
- The unit has been modified by the OEM or end user.
- The unit has been installed without respecting the instructions provided in this manual.
- The unit is used without respecting the instructions provided in this manual.
- The unit has not been subject to routine functional inspection.
- The unit has not been subject to routine maintenance.
- The unit has been repaired with unoriginal spare parts.
- Ralco shall decline all responsibility for any damage, direct or indirect, caused to persons or things by inappropriate accessories.

WARNINGS



INFORMATION REGARDING ACCIDENTS THAT HAVE OCCURRED WHILE USING THE RADIOLOGICAL COLLIMATOR MUST BE REPORTED IMMEDIATELY TO RALCO SRL.

RESIDUAL RISKS

The collimator has been constructed to current standards to meet the safety requisites of directive 2007/47/CE. However, due to the presence of x-rays, the type of application implies a residual risk derived from possible faults that could occur during operation of the unit.

The Instructions contained in the this Manual will ensure the correct use of the device and reduce the causes of possible hazards.

The residual risks of the device are reasonable; they have been assessed and approved in the related Risk Management Plan contained the Technical Report.

Information For The Manufacturer

The following form is provided for your comments and suggestions with regards to the collimator so that we may ensure and improve the quality of our production.

Please e-mail comments and/or suggestions to: repairs@ralco.it

Date:

Customer:

Information regarding possible accidents that may have occurred while using the collimator.

Directive 2007/47/CE states that accidents (such as death or grievous injury to a patient) that involve the collimator described herein, must be reported to the Ministry of Health and to the Manufacturer.

The present form is provided to report to Ralco srl post-free.

Date:

Customer:

