

REVISION TEXT HISTORY FOR B928 MANUAL

REVISION	ECR	DESCRIPTION	RELEASE DATE
L	4395	Separated coversheet from manual and updated page header	December 2004
M	4484	Added error codes and tube protect DIP SW settings due to 02249-000 timer board; Added text revision history page, and updated TOC	February 2005
N	4727	Updated TOC to include 02581 Service Guide	August 2005
P	5595	Added note to 2b) concerning tube stator impedance	March 2008
Q	7899	Converted to Service Part	March 2013

TABLE OF CONTENTS

I.	INTRODUCTION	2
II.	USER INFORMATION	3
	A. CONTROL FEATURES	3
	B. RECOMMENDED OPERATING PROCEDURES	6
	C. MAINTENANCE	8
	D. TECHNICAL INFORMATION	9
III.	ASSEMBLER INFORMATION.....	11
	A. CERTIFICATION OF COMPATIBILITY.....	11
	B. RADIATION PROTECTION	11
	C. ELECTRICAL POWER SUPPLY REQUIREMENTS	11
	D. UNPACKING AND OPENING CONTROL.....	12
	E. PRELIMINARY ASSEMBLY and TUBE PROTECT SELECTIONS.....	14
	F. PRELIMINARY ELECTRICAL CHECKS AND ADJUSTMENTS	18
	G. CALIBRATION.....	20
	H. FINAL COMPLIANCE TESTS	27
	I. ANCHORING CONTROL CABINET TO THE FLOOR	29
	J. SCHEMATICS	
	1. 02249-002—COMPONENT LAYOUT FOR TIMER DRIVER PCBA....	30
	2. B130--SCHEMATIC, MOTOR START CRCT.....	31
	3. B131--PARTS LAYOUT FOR MOTOR START CRCT (A455).....	32
	4. B133--HIGH TENSION TRANSFORMER DIAGRAM A700	33
	5. B934--360 CONTROL CIRCUIT DIAGRAM, B360	34
	6. B939--SCHEMATIC FOR kVp COMP PCB ASS'Y (1206).....	35
	7. 02249-003—SCHEMATIC FOR TIMER DRIVER PCBA.....	36
	K. SERVICE GUIDE, SINGLE-PHASE GENERATORS (02581).....	37

I. INTRODUCTION

The equipment, which is described in this manual, will perform reliably when installed, operated, and maintained in accordance with the instructions of this manual.

This equipment is sold with the understanding that the user assumes sole responsibility for radiation safety and that the manufacturer does not accept any responsibility for the following:

1. Equipment improperly installed.
2. Equipment improperly used.
3. Equipment improperly maintained or repaired.
4. Equipment, which has been modified or altered in any way.
5. Injury or damage to patient or other personnel for any of the above causes.

We are proud of our products and are confident they will provide many years of useful and enjoyable service.

Summit Industries Inc.

II. USER INFORMATION

This x-ray generator is both easy to use and very versatile. It consists of an x-ray control and a high voltage generator (H.V. generator).

A. CONTROL FEATURES

Refer to photo on page 6 for location of the following controls and indicators:

Note: Refer to Section B, “Recommended Operating Procedure” for detailed description of proper use of these controls and indicators.

- A) Power “on” – “off” switch – Controls power to the system.
- B) Power “on” light – Indicator light lights when power is “on”.
- C) Bucky selector switch – Allows selection of either wall bucky, table bucky, or no bucky.
- D) Line check rocker switch – When depressed, this switch causes the kVp meter (O) to indicate if the line voltage compensator (E) is adjusted properly.
- E) Line voltage compensator – Allows operator to adjust input circuit of x-ray control to match the line voltage easily and effectively.
- F) Tube current (mA) selector switch – Rotary switch allows operator to select the optimum tube current and focal spot for the desired technique.
- G) Digital display – This display provides three very useful features:
 1. Pre-exposure indication of mAs (the product of mA and exposure time).
 2. Post-exposure indication of the number of x-ray pulses counted during the previous exposure.
 3. Error codes to indicate generator status or inappropriate selection.

<u>Error Code</u>	<u>Indicated Fault</u>	<u>Corrective Action Required</u>
E01	Tube Limits Exceeded	Reduce kVp, mA or Time
E02	kVp too high (>128 kVp)	Select 125 kVp or less
E03	kVp too low (<37 kVp)	Select 40 kVp or more
E04	Invalid mA setting	Reselect mA station
E06	Invalid Time Selection or Leaking SCR	Reselect Time station, call for service if error won't clear.

We recommend that the above chart be kept available for easy reference.

- H) X-ray exposure switch – Two level switch: Partial depression (PREP) causes anode rotation and filament current boost. Full depression (EXPOSE) initiates the production of x-rays.
- I) Exposure time selector switch – Provides the operator capability to select any one of 23 different exposure times.
- J) Exposure interlock “ready” light – Indicator light lights when all exposure interlocks are closed. (Collimator interlock, tube thermal protection, misc. exposure interlock devices, etc.) When this light is “off”, exposures will not be allowed.
- K) Tube ratings exceeded light – Indicator light lights when internal electronic circuitry detects that selected technique factors exceed the single exposure ratings of the x-ray tube. Under these conditions, x-ray exposures are not allowed.
- L) Milliampere meter – Indicates actual tube current during an x-ray exposure. Meter deflection is the visual indication of x-ray production.
- M) kVp minor selector – Provides fine adjustment of peak tube potential (kVp).
- N) kVp major selector – Provides coarse adjustment of peak tube potential (kVp).
- O) KILOVOLT meter – Pre-reading meter, which indicates selected peak tube potential (kVp). This meter also serves as an indicator of line voltage adjustment in conjunction with item (D) above.

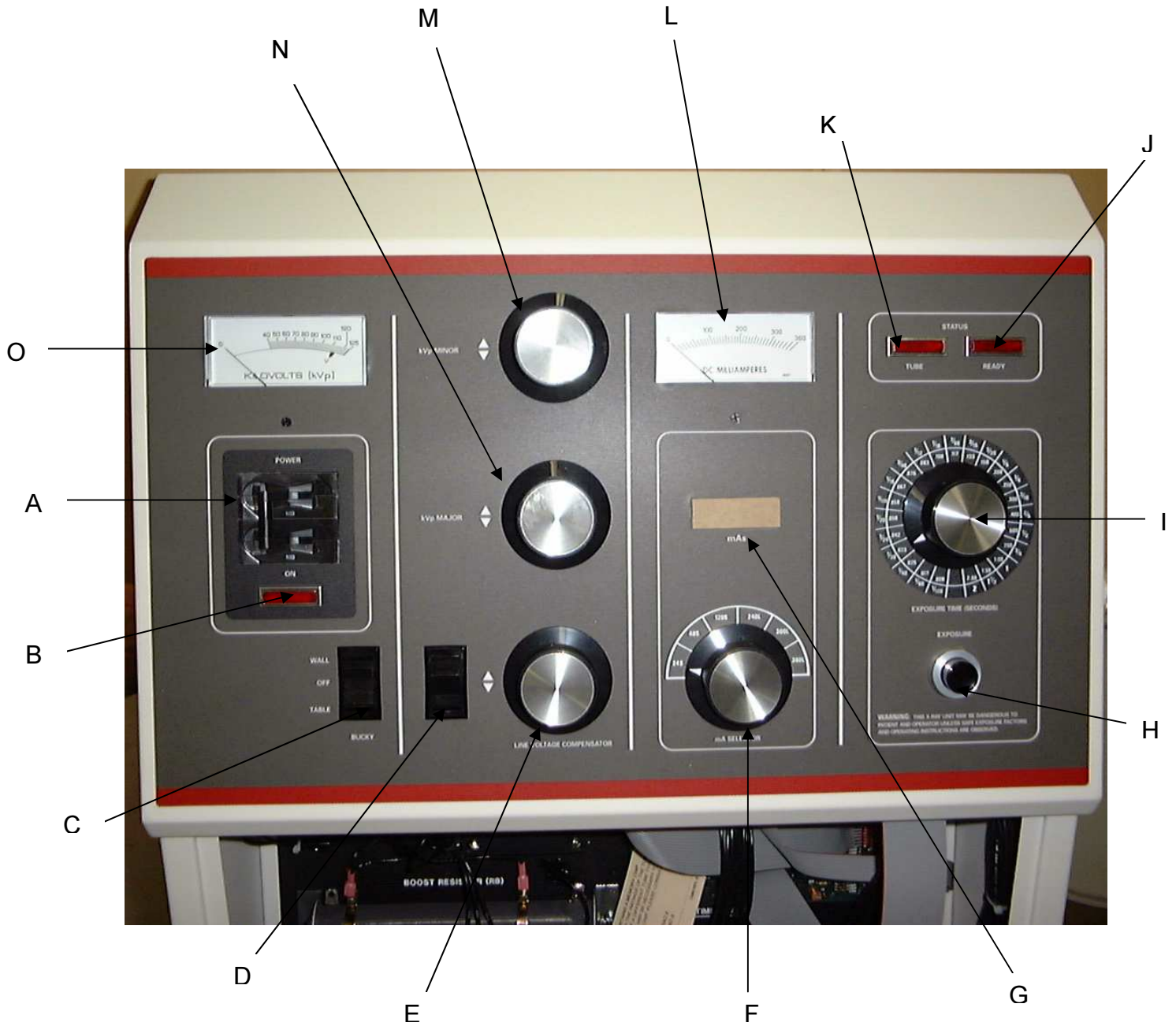

B. RECOMMENDED OPERATING PROCEDURES

Note: It is important to turn the generator “on” at least 15 minutes before making an exposure. This will provide sufficient “warm-up” time for the circuitry to stabilize.

1. Turn the system “on” by slowly snapping the power switch (A) to the right. Power “on” light (B) should light.
2. Check the line voltage by depressing “line check rocker switch” (D) while observing the kVp meter (O). Rotate the knob of the “line voltage compensator” (E) as necessary until the needle of the kVp meter falls within darkened area of the scale marked “V” (as near the center of the area as possible.)

Note: If you are unable to position the needle within this area, it is an indication that the line voltage is not correct and the equipment should not be used. Either wait for line voltage to change or call for service.

3. Determine the desired technique factors. **Note: Do not exceed the x-ray tube ratings. Refer to x-ray tube rating charts provided with the x-ray tube. If the technique factors are set beyond the x-ray tube limits “E01” should appear in the digital display window, preventing exposure.**

Note: Proper warm-up of the anode must be done on a cold unit prior to making exposures. The specific details may be found in “General Information for Installing and Operating X-Ray Tubes”, that is included with each tube shipped. The warm-up procedure tags are attached to each unit. Basically this procedure will reduce the chance of tube damage due to thermal shock.

4. Select the desired tube current. Selecting the 24, 48, or 120 mA stations automatically determine that the small Focal Spot. will be used. The 240, 300, and 360 mA stations are internally connected to the large F.S.

Note: Select the desired tube current (mA) prior to selecting the desired peak tube potential (kVp).

If at any time, a different tube current is selected, it will be necessary to reset the kVp selector switches.

5. Rotate the exposure time selector switch (I) to the desired time setting.
6. Observe the digital display (G) to confirm that the correct mAs has been selected.
7. Select the desired peak tube potential (kVp) by observing the kVp meter (O) while rotating the kVp selectors (M&N)

8. This generator is equipped with tube protect circuitry that compares the selected technique factors to the “single exposure ratings” of the x-ray tube. Exposures will only be allowed if the selected values are less than or equal to the x-ray tube limits. Refer to the chart below for description of “E01” error.
9. If the x-ray system includes a bucky (wall or table or both) and it is desired to use a bucky technique, select the appropriate bucky by depressing the bucky selector switch. If a non-bucky technique is desired select the center “off” position of the bucky selector switch.
10. This generator is also equipped with an indicator light identified as “exposure interlocks ready” light, which monitors the status of all auxiliary exposure interlock circuitry. When all interlocks are ready the light will light. If the light is not “on”, x-ray exposures will not be allowed. Such interlocks might be SID interlock switches, tube thermal protectors, collimator interlock, etc.
11. Depress the exposure switch approximately halfway. This action will cause the rotating anode of the x-ray tube to accelerate to full speed and the selected filament of the x-ray tube to heat up to its proper emission temperature. Depress the exposure switch fully and hold. A beep tone will indicate the termination of the exposure, and the mA meter deflection will provide a visual indication of x-ray production.

Note: It is permissible to depress the exposure switch fully in one motion. There will be however, a one second delay before x-ray production begins.

After the exposure terminates, but while the exposure switch is still depressed, the digital display will flash “on” and “off” indicating the number of x-ray pulses produced. This is primarily a service feature, and as a user, you may ignore this flashing display.

12. Error codes and corrective action for digital display window.

<u>Error Code</u>	<u>Indicated Fault</u>	<u>Corrective Action Required</u>
E01	Tube Limits Exceeded	Reduce kVp, mA or Time
E02	kVp too high (>128 kVp)	Select 125 kVp or less
E03	kVp too low (<37 kVp)	Select 40 kVp or more
E04	Invalid mA setting	Reselect mA station
E06	Invalid Time Selection or Leaking SCR	Reselect Time station, call for service if error won't clear.

C. MAINTENANCE

Periodic inspection and preventative maintenance of this equipment is necessary to assure continued safe performance and compliance with applicable state and federal regulations. The following maintenance program must be closely followed:

Q: Who should perform the service?

A: Service personnel specifically trained, experienced, and familiar with this type of medical x-ray equipment.

Q: When and How often?

A: Appropriate inspection and service should be performed 30 days after installation and every 6 months thereafter.

Q: Specifically, what must be inspected, tested and/or serviced?

A: Several things:

1. Verify that the knob on exposure time selector is mounted solidly and indicates the proper value.
2. Verify that all push-button and rocker switches operate freely with no sticking or hanging up.
3. Verify proper operation of all pilot lights.
4. Verify proper operation of audible and visual indicators of x-ray termination and production respectively.
5. Verify the accuracy of exposure timer, tube current, and peak tube potential, and adjust as necessary.
6. Perform reproducibility and linearity tests and verify compliance.
7. Inspect electro-mechanical contactor for pitting and/or burned contacts. Replace if necessary.
8. Examine terminal connections of high voltage generator. All terminals should be tight.
9. Examine oil level of H.V. generator and refill as necessary. There should be approximately $\frac{1}{2}$ " to $\frac{3}{4}$ " air space between the oil and the inside edge of the generator cover.
10. Examine the plugs of the high voltage cables. They should be clean with no signs of carbon tracking.

Note: This x-ray generator should not be altered or modified in any way as such action may invalidate its regulatory compliance and void the factory warranty.

D. TECHNICAL INFORMATION

Rated line voltage – 240 VAC, 60 Hz., single phase.

Range of line voltage regulation at max. line current = 1-5%

Maximum line current based on input voltage of 240 VAC -160A.

Technique factors that constitute the maximum line current – 360 mA @ 115 kVp.

Generator rating-

Output Current = 24-360mA.

Output Voltage = 40-125kVp.

Generator duty cycle-

120mA @ 125 kVp – 4%

240mA @ 125kVp – 2%

360mA @ 115kVp – 1%

Maximum Deviation

The following maximum deviation statements are broad and considered “worst case” conditions.

Typical performance will normally be significantly better.

Peak Tube Potential (kVp)

The Maximum Deviation of the Peak Tube Potential during an exposure from its pre-indicated value is $\pm 20\%$ of the kVp meter’s full-scale value. The measurement basis upon which the peak tube potential is defined is a calibrated high voltage divider unit such as the Machlett Dynalyzer.

Tube Current

The Maximum Deviation of the tube current during an exposure from its pre-indicated value is $\pm 10\%$ of selected value within a kVp range of 50-125 kVp (inclusive), and $\pm 20\%$ of selected value within a kVp range of 40-50 kVp (exclusive). The measurement basis upon which the tube current is defined is a calibrated D.C. milliammeter in series with the x-ray tube.

Exposure Time

The maximum deviation of the measured exposure time from its pre-indicated values is

- ± 1 pulse for selected times within the range of 1/120 – 1/10 sec.
- $\pm 15\%$ of selected times within the range of 7/60-2 sec.

The measurement basis upon which the exposure time is defined as the number of half cycle impulses of the 60 Hz power line measured either at the primary of the high voltage generator with an oscilloscope or in the secondary of the high voltage generator by means of a high voltage divider unit and an oscilloscope.

Tube Current-Exposure Time Product

The digital display of mAs provided is not a primary indication of technique factors. It is intended solely as an auxiliary indication to verify the product of the primary control settings: tube current and exposure time. As such, a statement of maximum deviation is not provided.

III. ASSEMBLER INFORMATION

A. CERTIFICATION OF COMPATIBILITY

The manufacturer certifies that its certified x-ray controls and high voltage generators are compatible with all certified x-ray tubes concerning compliance with 21CFR, Chapter I, Sub-chapter J, only if the ratings of the controls, generators and tubes are strictly observed and the control is calibrated within the applicable published limits.

Our certified controls and generators, when combined with other certified components, will not affect the compliance of these components when these components are installed, connected and adjusted in accordance with the applicable manufacturer's instructions and specifications.

Note: It is the assembler's responsibility to verify compatibility of all components assembled as parts of the x-ray system. Refer to compatibility statements published by the component manufacturer for this specific information.

B. RADIATION PROTECTION

Most states and local governments have regulations, which specify minimum safety requirements for radiation protection. Consult your local regulations for specific requirements.

C. ELECTRICAL POWER SUPPLY REQUIREMENTS

The information provided below is taken from NFMA standards, Minimum Power Supply Requirements for X-Ray Machines, and National Electric Code.

Equipment Category – 360mA at 115kVp, single phase.

Nominal Line Voltage – 240 VAC., 60 Hz., single phase.

Note: Alternate line voltages, which will provide normal operation, are 208-277 VAC.

Maximum Momentary Line Current – 160 amperes (at 240 VAC)

Note: Maximum momentary line current at alternate line voltages can be determined using the following formula:

$$I_2 = \frac{160 \times 240}{V_2}$$

where V_2 represents the alternate line voltage, and
where I_2 represents the maximum line current at the alternate line voltage, " V_2 ".

Line Voltage Regulation – Not to exceed 5% at maximum line current.

$$\text{Percent line voltage regulation} = \frac{V_N - V_L}{V_L} \times 100$$

where V_N represents the line voltage under “no load” conditions.

V_L represents line voltage under “full load” conditions.

Minimum Over Current Protection Rating – 50% of maximum line current rating or greater. Assuming maximum line current to be 160 amps, this value would be 80 amperes or greater.

Wire Size from Power Transformer to Disconnect Switch – for 50 feet use #2AWG; for 100 feet use #00AWG; for 200 feet use 250mcm
(mcm – thousand circular mils.)

Connection to Supply Circuit (taken from N.F.P.A. 70-1984)

A disconnecting means of adequate capacity for at least 50% of the input required for the momentary rating shall be provided in the supply circuit. The disconnecting means shall be operable from a location readily accessible from the x-ray control. Underwriters Laboratories also requires that this disconnecting means be mounted on either the wall behind the x-ray control or the wall directly adjacent to it.

D. UNPACKING AND OPENING CONTROL

1. Open all cartons carefully and examine contents. If damage is found notify the freight company immediately to file claim. Do not dispose of cartons or packing materials until installation is complete, and any damage claims have been settled.
2. Verify that the oil level in the H.V. generator is approximately $\frac{1}{2}$ " to $\frac{3}{4}$ " below the underside of the cover. Refill with “Shell Diala oil AX” or equivalent as necessary.
3. Once the H.V. generator is in its final location, loosen the screw on the vent plug to allow for oil expansion. Cover the vent plug and flange with one of the loose fitting plastic covers provided with the H.V. generator to prevent contaminants from entering the oil.
4. To open control for service, loosen the lockdown screws (one on each side) and tilt the control lid assembly forward.

6. Grasp the “lift tab” at the center of the front panel (near the top) and lift upwards approximately 1” to unhook the bottom of the front panel from the base of the cabinet. While holding the panel up, push out the bottom and lower it to the floor. Then tilt the lid back to its normal position so that the front panel can be removed.
7. See photo below for parts layout of electrical chassis assembly.

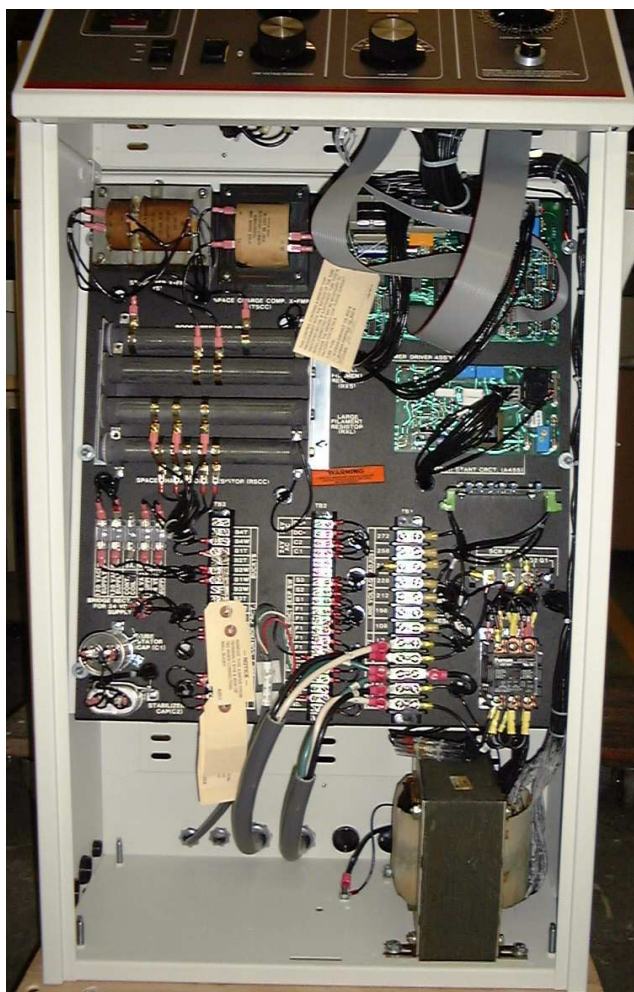

E. PRELIMINARY ASSEMBLY AND TUBE PROTECT SELECTIONS

1. Before starting the generator installation, it should be noted that an alternate set of holes are provided in the side of the control cabinet to allow cable entry/exit from either the back (as shipped) or the left side. If the location of the control requires cable mounting on the side, remove the hole plugs and transfer the cable clamps and cables from the back of the control to the side. Then reinstall the hole plugs into the set of holes in the back of the control.

2. Connect x-ray tube

- a) High voltage cables (HV cables) – The high voltage generator requires the use of H.V. cables constructed with federal terminals. **Note: Use extreme care when handling the H.V. cables to avoid damaging the plug or terminal pins.**

Be sure that “Anode” of H.V. generator connects to “Anode” of x-ray tube, and “Cathode” to “Cathode”. H.V. cable terminals must be thoroughly cleaned and then coated with a thick coating of Vapor Proofing Compound (normally provided with the x-ray tube) prior to insertion into the x-ray tube or H.V. generator receptacles.

Insert the H.V. cable terminals into the appropriate receptacle and screw the cable nut as tightly as possible by hand – **do not use tools for tightening.**

- b) Stator cable – This x-ray control will accept either a 3 or 5 wire tube stator cable. The terminals of the x-ray control are on TB3 and are marked 07, 08, 09, T5, and T6.

TERMINAL MARKINGS OF (TB3)	CONNECTIONS	COLOR CODE FOR STATOR CABLE		
		EUREKA/ VARIAN TUBES	MACHLETT TUBES	SUMMIT AND TOSHIBA TUBES
07	RUN WDG. OF TUBE STATOR	BLACK	BLACK	BLACK
08	START WDG. OF TUBE STATOR	RED	GREEN	RED
09	COM. LEAD OF TUBE STATOR	WHITE	WHITE	WHITE
T5	*THERMAL CUTOUT SWITCH (OPTIONAL)	ORANGE/ BROWN	----	YELLOW
T6	*THERMAL CUTOUT SWITCH (OPTIONAL)	BROWN/ ORANGE	----	BLUE

*If tube has thermal cutout switch, remove jumper across T5 and T6 and connect leads as indicated. If tube does not have thermal cutout switch, terminals T5 and T6 must be jumpered together. (Control is shipped with this jumper installed.)

*The Rotor Start Circuit in this Control is compatible with the following

Tube Stator Impedance:

STATOR RESISTANCE:

Common to Main 25-30 OHMS

Common to Phase 50-60 OHMS

Main to Phase 75-90 OHMS

3. Connect high voltage generator to control –
 - a) The 25' primary cable for the H.V. generator is connected to the control at the factory. The loose end, marked P1, P2, and GND, should be connected to the corresponding terminals of the H.V. generator.
 - b) The 25' filament supply cable for the H.V. generator is connected to the control at the factory. The loose ends, marked XC, XS, XL, and MI are to be connected to the corresponding terminals of the H.V. generator.
4. Connect collimator and/or electric locks (if applicable) –

This x-ray control is provided with fused power supplies rated 24 VAC, 10Amp. Max. (terminals "C1" and "C2" of TB2) and 24 VDC 8Amp max. (terminal "DC+" and "DC-" of TB2)

5. Exposure interlock circuits –

This x-ray control provides pairs of terminals which can be used to connect auxiliary interlock circuitry which inhibit x-ray exposures. These terminal pairs are marked T6/T7, and T7/F2 of TB3. Removable jumper clips are connected across these terminals at the factory. If it is necessary to connect an interlock switch into the exposure circuit, remove one of these jumpers and connect the interlock leads across the opened terminals. **Note: Any interlock switch to be used must be rated 125 VAC, 2 Amps minimum.**

6. Bucky connections –

This control provides terminals which can be used to operate one or two buckys. The terminals are designated B1W, B2W, B3W, and B4W for "wall" buckys; and B1T, B2T, B3T, and B4T for "table" buckys. Since several types of buckys may be used, be sure to connect bucky to appropriate terminals as indicated below. All buckys must be configured for 115 VAC operation.

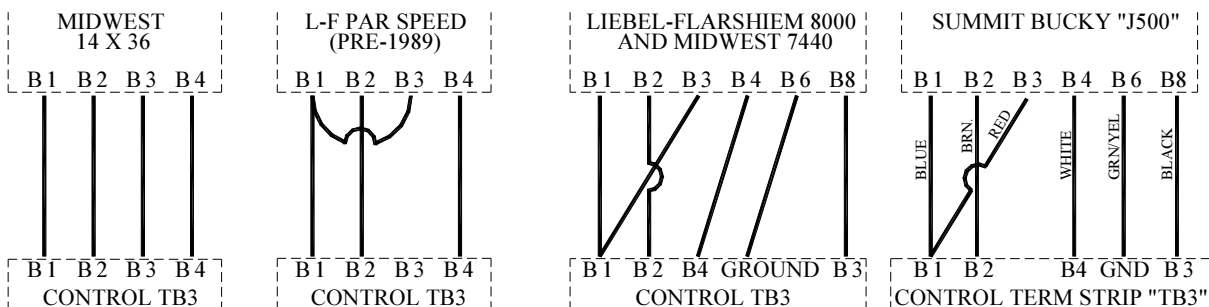

Note – Remove jumper clip across B1T and B2T on TB3 when connecting "table" bucky, or B1W and B2W on TB3 when connecting "wall" bucky.

7. Auxiliary exposure switch –

Terminals have been provided in the control for connecting an auxiliary exposure switch. They are on TB2 and are marked S1, S2, and S3. Refer to control circuit schematic for connection details.

8. Power supply –

A 13 ft. line cable marked L1, L2, and GND is provided. One end is connected to the control at the factory. The other end is to be connected to the disconnect switch to the appropriate terminals. The disconnect switch should be “off” before making connections. Be sure to connect the green “GND” lead to a “GOOD” ground.

9. Tube Protect DIP Switch Selection –

The 02249-000 timer board has a DIP switch (S1) to select the tube protect factors for the x-tube type used at this installation. The new U1 chip will be labeled with generator type (325 or 360), line frequency (50 or 60 Hz), and tube manufacturer (Summit/Toshiba or Varian/Eureka). Verify the chip type installed is appropriate for the generator, line frequency and tube type at this site. DIP SW1 positions will select the specific type of x-ray tube insert at this site (see table below). On the DIP switch “OFF” is to the left, “ON” is to the right. Any change to the DIP S1 settings must be done while the generator is turned OFF.

Tube Mfg, Insert, (Focal Spot)	DIP SW (S1) Settings		
	S1-1	S1-2	S1-3
Toshiba E7239 (1.0/2.0)	OFF	OFF	inactive
Toshiba E7242 (0.6/1.5)	OFF	ON	inactive
Toshiba E7252 (0.6/1.2)	ON	OFF	inactive
Toshiba E7813 (1.0/2.0)	ON	ON	inactive
Varian Rad 8 (1.0/2.0)	OFF	OFF	inactive
Varian Rad 74 (0.6/1.5)	OFF	ON	inactive
Varian Rad 14 (0.6/1.2)	ON	OFF	inactive
Varian Rad 13 (1.0/2.0)	ON	ON	inactive

F. PRELIMINARY ELECTRICAL CHECKS AND ADJUSTMENTS

1. Line voltage adjustments –

Terminals in the control on TBI are provided for coarse adjustments of line voltage. Measure the line voltage at the disconnect switch and relocate wire marked LVA to the corresponding terminal. See below for details:

If line voltage measures 190-203V connect LVA lead to term “198”

If line voltage measures 204-219V connect LVA lead to term “212”

If line voltage measures 220-233V connect LVA lead to term “228”

If line voltage measures 234-249V connect LVA lead to term “242”

If line voltage measures 250-263V connect LVA lead to term “258”

If line voltage measures 264-280V connect LVA lead to term “272”

2. Preset all selector switches –

Prior to turning “on” power, set each selector switch as follows:

Power “on-off”	-	“off”
Bucky switch	-	“off”
kVp major and minor	-	fully counterclockwise
Line voltage compensator	-	approximately halfway
mA selector	-	240L
Time selector	-	1/120 sec.

3. Disconnect leads marked P1 and P2 from H.V. generator and insulate with electrical tape. This will prevent accidental production of x-rays during initial check-out. Switch the disconnect switch “on” and then switch the control’s “on-off” switch “on”.

Observe the following:

- Power “on” light is lit.
- kVp meter indicates approximately 20 kVp.
- mA meter indicates zero.
- mAs display indicates E03 (kVp too low).
- Tube ratings exceeded light “lit”.
- Exposure ready light lit.

Note that the 02249-000 timer board will display a variety of error codes per the table below. If more than one selection is invalid the highest number will take precedence. For example, an invalid mA and kVp too low would display as E04. Once the mA error is cleared the kVp low error E03 would then be displayed.

<u>Error Code</u>	<u>Indicated Fault</u>	<u>Corrective Action Required</u>
E01	Tube Limits Exceeded	Reduce kVp, mA or Time
E02	kVp too high (>128 kVp)	Select 125 kVp or less
E03	kVp too low (<37 kVp)	Select 40 kVp or more
E04	Invalid mA setting	Reselect mA station
E06	Invalid Time Selection or Leaking SCR	Reselect Time station, call for service if error won't clear.

4. Depress and hold "line check rocker switch" and observe kVp meter. Rotate line voltage compensator until kVp meter needle is in the black area of the scale marked "V". Release line check rocker switch.
5. While observing the tube filaments through the port of the x-ray tube, verify that the correct filament is lit for each mA station.
6. Depress the exposure switch to the 1st stage (prep.) and verify anode rotation and filament boost.
7. The kVp meter circuit is factory adjusted, but should be checked to verify approximate calibration.
 - a) With power "off" connect an "AC" voltmeter capable of reading 0-250 VAC across the wipers (center terminals of tap switches) of the KV selector switches (major and minor). This will allow measurement of the "no-load" primary voltage.
 - b) Turn "on" power and adjust the kVp selector switches to result in 220 VAC indicated on the voltmeter.
 - c) Compare the kVp meter indications for all mA stations with the values given below:

mA STATION	kVp METER INDICATION (kVp)
24	118
48	116
120	108
240	94
300	86
360	74

Then reset kVp selectors to result in voltmeter indication of 160 VAC.

mA STATION	kVp METER INDICATION (kVp)
24	84
48	82
120	74
240	60
300	52
360	40

If the kVp meter indication varies by more than 5 kVp from the values given above, proceed to the kVp calibration procedure (page 23).

8. Check proper operation of all auxiliary devices and interlocks (electric locks, collimator, auxiliary exposure switch, bucky, etc.)
9. Switch the disconnect switch "off" and reconnect the leads P1 and P2 to the H.V. generator.

G. CALIBRATION

This x-ray generator has been fully tested and calibrated using a "production test" x-ray tube. Because the tube characteristics of this tube may vary from the tube characteristics of the specific tube being installed, the assembler must check the accuracy of the tube current, and make the appropriate adjustments.

This equipment has been designed and calibrated based on proper connection to a power supply as described below:

- Nominal line voltage – 190-280 VAC 60 Hz. single phase
- Maximum line voltage regulation – 5% at full rated load (360 mA 115 kVp)

Calibration will normally involve only slight adjustments of the tube current and verification of KV accuracy.

It is recommended that the assembler read and understand the information provided with the x-ray tube prior to making any x-ray exposures. Particular attention should be given to:

- a) Pre-warming of the anode
- b) Initial seasoning of the x-ray tube
- c) One shot tube ratings
- d) Long time accumulated heat ratings

It is also recommended that measuring equipment be connected into the x-ray system and used to monitor mA and kVp throughout the calibration procedure. This reduces the chances of misleading test data and unnecessary backtracking.

1. Calibration of Tube Current

Achieving maximum accuracy of tube current involves two types of adjustments:

- Overall mA level (bands of filament resistors RXS and RXL), AND
- mA balance throughout the useful kVp range (bands of space charge compensating resistor RSCC).

The leads connected to the resistor bands of RXS and RXL are marked with numbers, which correspond to the mA stations. Moving one of these bands to the right increases the tube current for the corresponding mA station.

The leads connected to the bands of RSCC are also marked with numbers, which correspond to the mA stations. Moving one of these bands to the right causes a reduction of mA at high kVp levels as compared to low kVp levels for the corresponding mA station. This is commonly referred to as the balance adjustment.

Note: If a band of RXS or RXL is all the way to the right & the corresponding tube current is not up to the proper level, it may be necessary to reposition the right-most band of Boost Resistor, "RB". Moving this band to the right causes tube current to increase for all mA stations.

- a) Select 240 mA and 80kVp
- b) Adjust the band of RXL marked 240 to produce approximately 250 mA (moving the band to the right increases mA).
- c) Select 50 kVp and note the mA produced.
- d) Select 120 kVp and note the mA produced.
- e) If the mA at 120 kVp is higher than the mA at 50kVp, move the band of RSCC marked 240 to the right. If lower, move the band to the left.
- f) Repeat steps (a) through (f) until no further adjustments are necessary.
- g) Check mA tracking from 50 to 120 kVp and fine tune as required. The unit is capable by fine tuning to deviate no more than approximately 5% of selected value. Due to the method of space charge compensation utilized, normal tracking will result in mA values slightly higher than selected near 80 kVp and mA values equal to one another but slightly lower than selected levels at the high and low ends of the kVp range (125 and 50). See below for visual presentation of this effect.

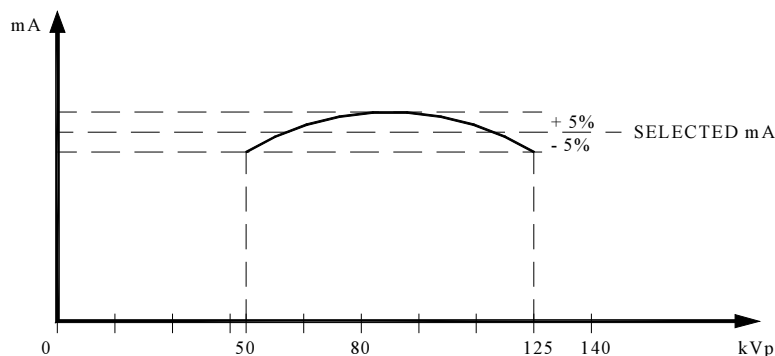

- h) Repeat steps (a) through (g) for the remaining mA stations:
Note: in step (b), use the following values in place of 250 mA.

MA STATION	MA
24	25
48	50
120	125
300	312
360	374

Note: Use 115 kVp instead of 120kVp in step D, E, & G.

2. Peak Tube Potential (kVp)

This x-ray generator comes equipped with an adjustable circuit used to compensate the kVp meter for loading effects. This circuit is identified as “kVp Meter Compensation Circuit”. Its adjustments consist of:

- (6) Independent offset pots (marked to correspond to the appropriate mA station)
- (2) Common slope pots: Rs for SMALL FIL. & RL FOR LARGE FIL.

These adjustment pots are all mounted onto a small P.C.B., which clearly identified inside the control on the electric chassis.

- a) Verify kVp meter movement accuracy.
 - 1) Connect a 250 VAC voltmeter of $\pm 1\%$ accuracy directly across the kVp meter terminals.
 - 2) Turn “on” the unit and rotate the KV selector switches major and minor to vary the voltage across the meter. Compare readings to the values in the table below. If kVp meter indication deviates from the values given by more than 3 kVp, the kVp meter may have to be replaced.

METER VOLTAGE (VAC)	kVp METER INDICATION
86	50 kVp
138	80 kVp
172	100 kVp
207	120 kVp

b) Verify kVp METER COMP. CIRCUIT input voltage and write down factory kVp METER offset calibration data.

- 1) Connect an AC voltmeter between TP-1 and Tp-2 of the kVp COMP. PCB. Verify that voltage is 100 VAC.
- 2) Turn unit power OFF. Disconnect connector J1of kVp METER COMP. PCBA. Turn power ON. Connect AC voltmeter between Tp-1 and Tp-3, measure the offset voltage for 24 mA station and enter result in the Table.
- 3) Repeat step 2 for all remaining mA stations using test points indicated in table below. Use results for future reference.
- 4) Turn power OFF. Reinstall connector J1, turn power ON

mA STATION	24 mA	48 mA	120 mA	240 mA	300 mA	360 mA
TEST POINTS	TP1-TP3	TP1-TP4	TP1-TP5	TP1-TP6	TP1-TP7	TP1-TP8
FACTORY CALIBRATION						
FIELD CALIBRATION						

c) Verify and adjust kVp meter accuracy (24, 48, & 120 mA stations)

- 1) Select 48 mA and 50 kVp. While monitoring mA and kVp output, compare the measured kVp to the kVp meter's pre-read indication.

Note: In order to make a valid comparison between the measured peak tube potential (kVp) and the kVp meter's pre-read indication, the tube current must be calibrated accurately. Failure to do so will result in an erroneous determination of kVp accuracy.

- 2) Adjust the 48 mA offset pot until the kVp meter's pre-read indication matches the measured kVp output.
- 3) Select 120 kVp. Make an x-ray exposure and adjust the common slope pot "Rs" until the kVp meter's pre-read indication matches the measured kVp output. Repeat steps 1, 2 and 3 above until no further adjustments are necessary.
- 4) Select 24 mA and 90 kVp; Adjust the 24 mA offset pot until the kVp meter's pre-read indication matches the measured kVp output.
- 5) Repeat step 4 for the 120 mA station, adjusting the corresponding pot as necessary.
- 6) Check final kVp meter tracking over the entire kVp range. Under normal conditions the kVp meter's indication will not deviate from the measured kVp output by more than 5 kVp.

- d) Verify and adjust kVp meter accuracy (240, 300, & 360mA stations)
- 1) Select 300mA and 50kVp. While monitoring mA and kVp output, compare the measured kVp to the kVp meter's pre-read indication.
 - 2) Adjust the 300mA offset pot until the kVp meter's pre-read indication matches the measured kVp output.
 - 3) Select 120 kVp. Make an x-ray exposure and adjust the slope pot "RL" until the kVp meter's pre-read indication matches the measured kVp output. Repeat steps 1, 2, & 3 above until no further adjustments are necessary.
 - 4) Select 240mA and 90 kVp. Adjust the 240mA offset pot until the kVp meter's pre-read indication matches the measured kVp output.
 - 5) Repeat step 4 for the 360 mA station, adjusting the corresponding pot as necessary.
 - 6) Check final kVp meter tracking over the entire kVp range. Under normal conditions the kVp meter's indication will not deviate from the measured kVp output by more than 5 kVp.
- e) Repeat step b for field kVp METER COMPENSATION CALIBRATION.

TYPICAL KVP METER CALIBRATION CURVES

THESE CALIBRATION CURVES ARE BASED ON A VOLTAGE SUPPLY LINE OF 240 VAC, WITH LINE VOLTAGE REGULATION OF 3.5%.

PERCENT LINE-VOLTAGE REGULATION = $\frac{100(V_n - V_L)}{V_L}$

WHERE V_n = NO-LOAD LINE VOLTAGE

V_L = FULL-LOAD LINE VOLTAGE (@ MAX. LINE CURRENT)

NOTE: IF LINE CONDITIONS VARY SIGNIFICANTLY FROM THOSE LISTED, CURVES FOR THE SPECIFIC CONDITIONS THAT EXIST MAY HAVE TO BE DEVELOPED.

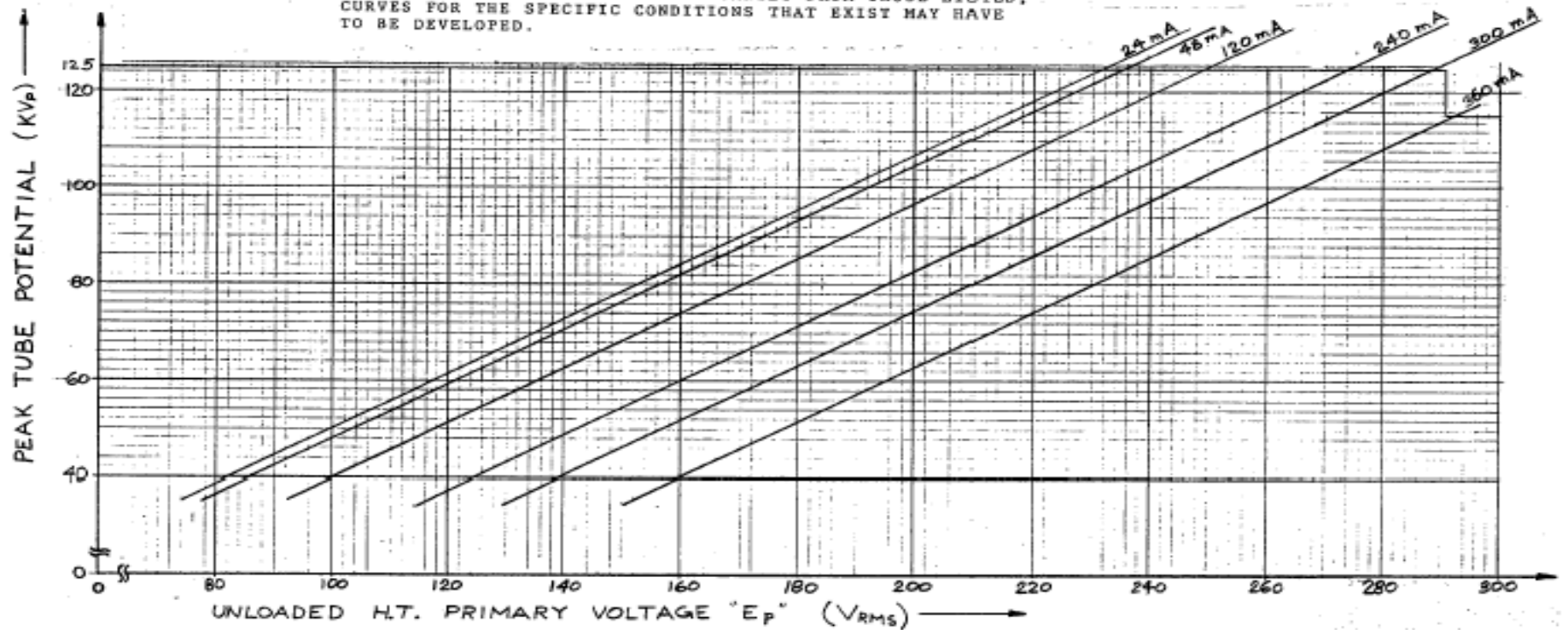

B954
 REV. A

H. FINAL COMPLIANCE TESTS

It is necessary for the assembler to perform tests on the newly-assembled x-ray system prior to release to the user. These tests must assure compliance with the applicable requirements of the FDA performance standard at the time of installation.

Perform these tests in accordance with NEMA publication #XR8-1979, Tests Methods for Diagnostic X-Ray Machines for Use During Initial Installation. It is necessary that the assembler document these tests to demonstrate at a later date that all tests were performed and that the x-ray system was left in full compliance with the standard. The test results obtained must verify that the following system specifications are met or the system must be removed from service until corrective action is completed.

SYSTEM SPECIFICATIONS

BEAM QUALITY

The half-value layer of the useful beam shall not be less than 3.5mm of aluminum.

REPRODUCIBILITY AND LINEARTIY

When the x-ray unit is operated on an adequate power supply (see section IIA): (1) the estimated coefficient of variation of radiation exposure shall not be greater than .048 for any specific combination of technique factors, and (2) the average ratios of exposure to the indicated tube current exposure time product (mAs) obtained at any two consecutive tube current settings shall not differ by more than .095 times their sum, or

$$\frac{|\bar{X}_1 - \bar{X}_2|}{\bar{X}_1 + \bar{X}_2} \leq 0.095$$

where \bar{X}_1 and \bar{X}_2 are the average mR/mAs values obtained at each of two consecutive tube current settings.

PEAK TUBE POTENTIAL

The maximum deviation of the peak tube potential from its preindicated value, during an exposure, when the equipment is connected to an adequate power supply (see section IIA) shall not exceed $\pm 19\%$ of full scale value within the range of 40-125 kVp.

TUBE CURRENT

The maximum deviation of the tube current from its preindicated value, during an exposure, when the equipment is connected to an adequate power supply (see section IIA) shall not exceed $\pm 9\%$ of selected tube current within the range of 50-125 kVp (inclusive), and $\pm 19\%$ of selected tube current within the range of 40-125 kVp (exclusive).

EXPOSURE TIME

The maximum deviation of the exposure time from its preindicated value, during an exposure, when the equipment is connected to an adequate power supply (see section IIA) shall not exceed ± 0 pulses within the range of 1/120-1/10 (inclusive) $\pm 14\%$ of selected time within the range of 7/60-2 seconds (inclusive).

I. ANCHORING CONTROL CABINET TO THE FLOOR

It is necessary, in order to meet regulations set forth by Underwriters Laboratories, to anchor the control cabinet to the floor. A 3/8 diameter hole is located centered in the bottom panel to accept an anchoring screw. See figure below. Select a fastener suited to the floor construction and condition; the finished installation must withstand a pull-out force of 440lbs to meet the test loading specified by U.L. When installing the anchor bolt into concrete floors use an expanding metal bushing, rather than one of the plastic or fiber sleeves. In wooden floors use a single lag screw only where the floor is known to be structurally sound. In wooden floors where the screw-holding strength is questionable make a mounting plate of 3/4 inch plywood, approximately 8" square, and with a "T-nut" located at the center. Attach the plate to the floor with several lag screws, and anchor the cabinet to the plate with a single machine screw. A space, 13/16-inch high, exists between the floor and the cabinet bottom panel to clear a 3/4" plywood plate. See figure.

