

Veterinary Radiographic System

**Operator's Manual
00856 REV. E**

**SUMMIT INDUSTRIES LLC
7555 N. Caldwell Ave.
Niles, IL 60714
1-800-972-9776
www.summitindustries.net**

Installation and Service Manual Revisions History

Revision	Pages Affected/Revision Description	Release Date	ECR #
A	RELEASED	APRIL 2002	
B	ADDED "COLD" AND "READY" DISPLAY MESSAGES, EXPOSURE COUNT DISPLAY	DEC. 2002	---
C	PAGES 6, 7, 9: ADDED NOTES FOR SYSTEMS WITHOUT TILT-OUT CONTROLS	JULY 2014	8448
D	UPDATED ADDRESS TO NILES, IL	JULY 2017	9607
E	CHANGE MANUAL FROM OBSOLETE TO SERVICE PART; CHANGE TO FREQUENCY OF SERVICE IN SECTION 6.0	EB. 2021	10705

TABLE OF CONTENTS

1.0 PRECAUTIONS	3
1.1 Installation	3
1.2 Operation	3
2.0 GENERAL PRODUCT OVERVIEW	5
2.1 Major Components.....	5
2.2 Specifications.....	7
2.3 Options	8
3.0 FUNCTIONS	9
3.1 Getting Started.....	9
3.2 Positioning the Tube	10
3.3 Collimator Operation	10
3.4 Setting Techniques	11
3.5 Making an X- Ray Exposure	11
3.6 Prep/Expose Tubestand Status Messages (for systems with digital tubestand displays)	12
4.0 TECHNICAL DATA	12
4.1 Radiation leakage (meets federal government standards).....	12
4.2 Rated line voltage: 240 VAC, 60 Hz., single phase.....	12
4.3 Range of line voltage regulation at max line current: 1% to 5%.....	13
4.4 Maximum line current (based on input voltage of 240 VAC): 140 AMP	13
4.5 Technique factors that constitute the max. line current: 300 mA @ 125 kVp..	13
4.6 Maximum Deviation of technique factors:	13
5.0 CLEANING	13
6.0 SCHEDULED DEALER MAINTENANCE	14
6.1 X-Ray Generator Maintenance	14
6.2 X-Ray Tube Housing.....	14
6.3 Collimator.....	15
6.4 Tubestand.....	15
6.5 Other.....	15
7.0 TROUBLESHOOTING	15
7.1 Error Message (on systems with digital tubestand displays).....	15
7.2 No Exposure	16
7.3 Collimator light bulb burned out.	16
7.4 No digital display (on systems with digital displays).....	17
7.5 Circuit tripping	17
7.6 Full kVp range inaccessible.	17
7.7 Poor film quality	17
8.0 WARRANTY NOTICE	18

1.0 PRECAUTIONS

1.1 Installation

This system must be installed and serviced by personnel authorized by Summit. All warranties will be void if such installation or service is performed by an unauthorized person.

1.2 Operation

1.2.1 Radiation

X-Rays are dangerous to both operator and others in the vicinity unless established safe exposure procedures are strictly observed.

The useful and scattered beams can produce serious, genetic or potentially fatal bodily injuries to any persons in the surrounding area if used by an unskilled operator. Adequate precautions must always be taken to avoid exposure to the useful beam, as well as to leakage radiation from within the source housing or to scattered radiation resulting from the passage of radiation through matter.

Those authorized to operate, test participate in or supervise the operation of the equipment must be thoroughly familiar and comply completely with the currently established safe exposure factors and procedures described in publications such as Sub-Chapter J of Title 21 of the Code of Federal Regulations "Diagnostic X-Ray Systems and their Major Components" and the National Council on Radiation Protection (NCRP) No.33, "Medical X-Ray and Gamma-Ray protection for energies up to 10 MeV-Equipment Design and Use", as revised or replaced in the future.

Failure to observe these warnings may cause serious, genetic or potentially fatal bodily injuries to the operator or those in the area.

1.2.2 Electrical

Only properly trained and qualified personnel should be permitted access to any internal parts. Live electrical terminals may be deadly. Be sure line disconnect switches are opened and other appropriate precautions are taken before opening access doors, removing enclosure panels, or attaching accessories.

Do not remove the flexible high-tension cables from the x-ray tube housing or high-tension generator or the access covers from the generator until the main and auxiliary power supplies have been disconnected.

When disconnecting high-voltage cables, they must be grounded immediately in order to dissipate any electrical charge that may remain on the cables or the tube.

Failure to comply with the foregoing may result in serious or potentially fatal bodily injuries to the operator or those in the area.

1.2.3 Mechanical

All of the movable assemblies and parts of x-ray equipment should be operated with care. Only properly trained and qualified personnel should be permitted access to any internal parts.

Particular care should be taken when servicing the inside of the tubestand. There is an extreme threat of mechanical pinching between the vertical slide and counterweight due to their close proximity and opposite directions of motion.

2.0 GENERAL PRODUCT OVERVIEW

2.1 Major Components

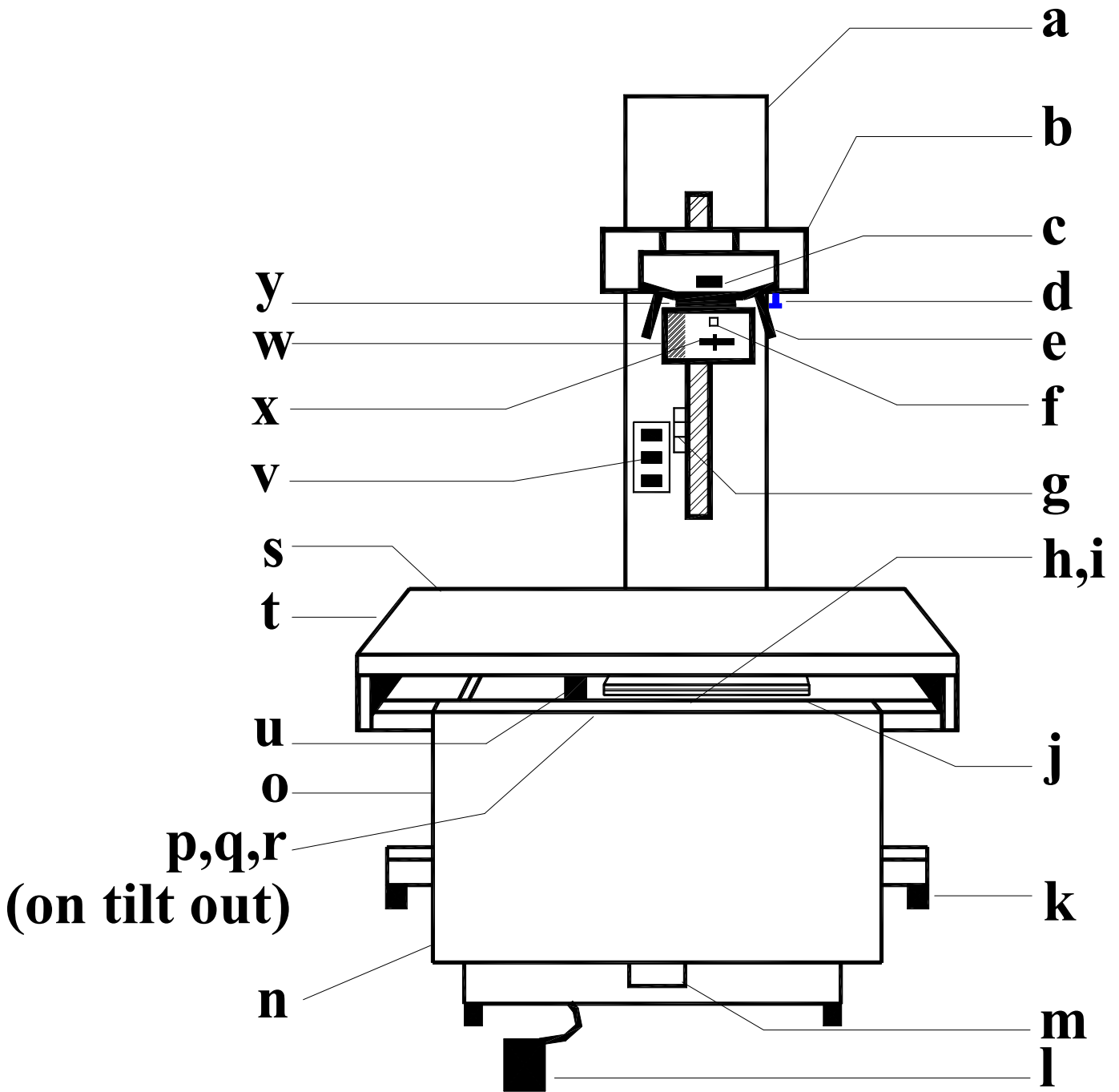

AW00856-01

-
- a. Tubestand - Supports collimator and x-ray tube. Moves both horizontally and vertically.
 - b. X-Ray Tube
 - c. Angulation Dial - Displays degree of x-ray tube angulation.
 - d. Angulation Lock - When loosened, allows angulation of x-ray tube.
 - e. Handle Grips - Used to move tube vertically or to angle the tube.
 - f. Light Switch Button - Turns collimator bulb on and off.
 - g. Source-Image Distance (SID) Indicator - When marker aligns with label on tubestand, SID (the distance between the tube focal spot and the film) is 40". There is a position for tabletop work and one for grid cabinet applications.
 - h. Grid Cabinet - Lead-lined cabinet holds cassette tray and grid.
 - i. Grid - Mounted to upper carriage of grid cabinet, absorbs scatter radiation for improved film clarity.
 - j. Cassette Tray - Molded indentions hold cassettes in correct position.
 - k. Rustproof Support Feet - Adjust to level the table.
 - l. Exposure Foot Switch - Used to make exposures.
 - m. Release Foot Pedal - When depressed, opens front of table to access control panel (on systems with tilt-out controls).
 - n. Table Base - All steel, welded construction.
 - o. Circuit Breaker - Turns generator on/off (Located on the side of the tilt-out panel on systems with tilt-out controls).
 - p. kVp Dials - One for major adjustment (15 kVp increments); One for minor (2 kVp increments).
 - q. mA Dial - Adjusts mA. Two stations: 300 and 100 when using small tube focal spot and 300 when using large.
 - r. Time Dial - Adjusts time. 18 stations available: 1/120, 1/60, 1/40, 1/30, 1/24, 1/20, 1/15, 1/12, 1/10, 1/8, 3/20, 1/5, 1/4, 2/5, 1/2, 5/8, 3/4, 1.
 - s. Drain Trough - Minimizes spillage behind table.
 - t. Table Top - 24" x 53" of Formica

-
-
- u. Tubestand/Grid Cabinet Interlock - When engaged, allows tubestand, grid cabinet and cassette tray to move together.
 - v. Digital Displays – Upper one for kVp; Center one for mAs, and Lower one for status & error messages.
 - w. Collimator - Controls size and rectangular shape of primary beam emitted from x-ray tube and provides coincident light field.
 - x. Shutter Adjustment Knobs - One each to determine width and depth of primary beam.
 - y. Swivel Mounting Plate - Allows collimator to be rotated.

2.2 Specifications

2.2.1 INTEGRATED GENERATOR (on systems with tilt-out controls)

- Tilt-out control.
- 300 mA at 125 kVp.
- Dual-digital timer with 18 time stations (1/120 to 1 second).
- Adjustable solid state audio exposure signal.
- SCR contactor.
- Programmable tube protect system.
- Tube overload sensor.
- Independent kVp and mA adjustment circuits for each mA station.
- Two mA stations: 100S and 300L.
- mA overload protection.
- 64 kVp stations (40 to 125).
- kVp selection, major 15 kVp increment, minor 2 kVp increment
- mA, time and kVp knobs.
- Built-in kVp compensation.
- Filament stabilization.
- 16-foot line cable; 4-foot control-to-transformer cable.
- Integral 24-Volt A.C. power supply.
- Programmable line frequency 50 or 60 Hz.
- Programmable power saving mode.
- Easy-access exposure count display.

2.2.2 TABLE / TUBESTAND

- Enclosed, integrated table. Removable 24" x 53" top.
- Welded base construction.
- Full-travel, lead-lined grid cabinet.
- 103-line, 8:1 aluminum grid.
- Grid cabinet/tubestand interlock.
- Tubestand-mounted digital kVp, mAs and status displays.
- Attached, counterbalanced tubestand; travels full table length.
- Angulation dial and operator handles.
- Two position foot switch.

2.2.3 CASSETTE HOLDER

- Easy-fit, removable, ABS plastic holder.
- Accepts 8" x 10", 10" x 12" and 14" x 17" cassettes in either direction.

2.2.4 TUBE

- 1.0-2.0 mm focal spots; 140,000 H.U.

2.2.5 CABLES

- 10' Max-Flex high voltage cables. Federal terminations.

2.2.6 COLLIMATOR

- Manual with light field.
- Swivel-mount.
- 90-second bulb "on" time.
- Gradual turn off warning (Soft Start Bulb Life feature).

2.3 Options

2.3.1 TABLE OPTIONS

- 12" table-top extension. Specify right or left.
- Upgrade grid to 10:1, 103 line.
- Animal restraining device.

2.3.2 TUBE / COLLIMATOR OPTIONS

- 0.6-1.5 mm; 200,000 H.U.
- Programmable lamp times - 30, 60, 90, and 120 seconds.

2.3.3 OTHER OPTIONS

- Remote exposure hand switch.
- Standard manual tray with sliding jaws; accepts all cassette sizes up to 14" x 17".

3.0 FUNCTIONS

3.1 Getting Started

3.1.1 Opening Unit (for systems with tilt-out controls) - Depress the Release Foot Pedal to open the front access door.

3.1.2 Powering On – To turn the generator on, move the circuit breaker switch to the up position. On systems with tilt-out controls, the switch is located at the left side of the hinged front door. For other systems, refer to the user manual for the particular X-ray generator.

It is a good idea to turn the unit off at the end of each day. This ultimately will extend your system's life. If power saving mode is selected, the unit turns off automatically.

3.1.3 Warming up - It is recommended that you warm up the unit prior to the first higher-powered exposure to prolong tube life. This is done by taking a series of three, 1/10 second exposures using the 300 mA station. Start with a kVp of 70 and increase to 80; then 90. Exposures should be spaced at least 20 seconds apart.

3.1.4 Loading Cassettes - Three sizes of cassettes can be used; 8" x 10", 10" x 12" and 14" x 17". Simply place the cassette into the specially-formed grooves of the tray. It will accept the cassette in either lengthwise or crosswise position.

3.1.5 Warming up generator - When the generator is first turned on after being turned off for two hours or more, the tubestand display will indicate "COLD". After ten minutes this display will change to "READY" which will scroll across the tubestand status window. The generator will take exposures when "COLD", but the outputs will be most accurate when the display indicates "READY". For consistent films wait for the "READY" indicator prior to taking exposures.

3.2 Positioning the Tube

- 3.2.1 Moving the Grid Cabinet - The grid cabinet can be moved in tandem with the tubestand, assuring alignment of the primary beam to the center of the film. The grid cabinet can be positioned anywhere along the entire length of the table. Grasp the tubestand handle grips and move to the desired location.
- 3.2.2 Disengaging the Grid Cabinet - Alternatively, the grid cabinet may be moved independent of the tubestand. Release the interlock by sliding the spring-loaded lever extending from the grid cabinet to the left. The grid cabinet may then move while the tubestand remains stationary. To re-engage the interlock, position grid cabinet in-line with tubestand. The interlock is engaged when you hear a metallic "click" sound and feel the interlock mechanism move into place.
- 3.2.3 Vertical Movement - The tube can be moved from 10-1/2" to 40" above the table top. For convenience, the SID markers indicate 40" positions from the table top or the grid cabinet. During vertical motion, you will note a pause at one height, which is the pre-set height for optimal exposure, set by adjusting the detents during installation.
- 3.2.4 Angulation - Release the lock, which is located on the right side of the tube arm. Grasp the handle grips and turn the tube to the proper angle. Turn the lock handle clockwise to hold tube position. The degree of rotation is indicated by a dial located between the handle grips.

3.3 Collimator Operation

- 3.3.1 Light Field - Once the tube is positioned relative to the grid cabinet, press the light button on the front of the collimator. A light field will appear. **WARNING! DO NOT LOOK DIRECTLY INTO LIGHT SOURCE AS RETINA DAMAGE COULD RESULT.**
- 3.3.2 Programmable Lamp Times - Lamp gradually turns off in one of the following selectable times: 30, 60, 90, 120 seconds. The factory setting is 90 seconds. If you push the button during the lamp's power down ramp, a new "on" cycle starts.
- 3.3.3 Collimator Adjustment - Use the sliding knobs to move the shutters. Scales indicate knob positions that correspond to common cassette sizes. Use the pointer to quickly move shutters into relative position, then fine tune to collimate the x-ray beam to the area of radiographic interest.
- 3.3.4 Swivel Movement - When doing table top work, you may want to swivel the collimator to avoid awkward patient positioning. Simply

swivel the collimator to the preferred position. **WARNING:** Do not touch the black lamp cover at the rear of the collimator as it gets quite hot. The collimator hesitates at the 0° and 90° positions for correct re-alignment.

3.4 Setting Techniques

3.4.1 mA - Adjust mA by moving the pointer to one of two stations: 100S or 300L.

When set at 100 mA, the small tube focal spot (1.0 mm in standard tube) is used, yielding a more finely detailed image. At 300 mA, the large focal spot (2.0 mm in standard tube) is used.

3.4.2 kVp - Two knobs control kVp - one for coarse adjustments of 15 kVp increments and one for fine tuning with 2 kVp adjustments.

Turn the knobs to select the desired kVp.

The kVp value is displayed on the tubestand-mounted display.

3.4.3 Time - The time dial can be set at any of 18 stations; these are marked both in fractions of seconds and in natural numbers: 1/120, 1/60, 1/40, 1/30, 1/24, 1/20, 1/15, 1/12, 1/10, 1/8, 3/20, 1/5, 1/4, 2/5, 1/2, 5/8, 3/4, 1.

3.5 Making an X- Ray Exposure

Note: If it is desired, to view the total number of X-ray exposures, simply turn the KVp major, KVp minor and mA selector knobs fully counter-clockwise. The bottom display will indicate "EXPO" and the KVp and mA displays will indicate the total number of exposures taken on this X-ray control.

There are two ways to make and X-ray exposure with the 2-position footswitch.

Prep and Expose Technique:

When proper patient position is achieved, partially depress the footswitch to activate the X-ray tube prep cycle. When "PREP" is displayed on the tubestand, watch the patient for respiration phase or proper restraint. At the desired moment, make the X-ray exposure by fully depressing the footswitch. An audible tone will indicate an exposure has been made.

Expose

When proper patient positioning is achieved, fully depress the exposure footswitch. The x-ray tube will begin its prep cycle and upon completion of

the prep cycle, the x-ray tube will make an exposure. An audible tone will indicate an exposure has been made. Note that in this procedure an x-ray exposure will not be made immediately upon depressing the footswitch. A delay will be experienced due to the x-ray tube prep cycle.

3.6 Prep/Expose Tubestand Status Messages

WAIT Tube is not yet warmed up. Please wait about 2 seconds. Exposures are not allowed yet.

PREP Tube is ready. Exposure starts immediately after initiating with foot switch.

X-RAY X-Ray exposure is in progress. Radiation is present.

DONE Exposure is completed.

COLD Unit needs to warm up for about ten minutes to achieve the most accurate exposure outputs.

READY Unit is warmed up and ready for taking exposures.

EXPOSURE COUNT

When the kVp major, kVp minor & mA selectors are in their fully counter-clockwise positions, the lowest digital display on the front of the tubestand will indicate "expo" (indicating "exposure count mode") & the kVp & mAs digital displays, also on the front of the tubestand, will indicate the total number of x-ray exposures that have been produced. To read the total exposure count, simply consider the number in the kVp display as the first & the number in the mAs display as the last 4 digits.

Examples:

- 1) When the kVp display indicates 12 & the mAs display indicates 6789, the total number of x-ray exposures is 126,789.
- 2) When the kVp display indicates 4 & the mAs display indicates 1000, the total number of x-ray exposures is 41,000.
- 3) When the kVp display is blank & the mAs display indicates 378, the total number of x-ray exposures is 378.

4.0 TECHNICAL DATA

4.1 Radiation leakage (meets federal government standards)

4.1.1 From the tube housing: less than 50 mR/hr at 1m from focal spot (@4mA, 125kVp)

4.1.2 From collimator: less than 50 mR/hr at 1m (@4mA, 125 kVp)

4.2 Rated line voltage: 240 VAC, 60 Hz., single phase.

-
-
- 4.3 Range of line voltage regulation at max line current: 1% to 5%.
 - 4.4 Maximum line current (based on input voltage of 240 VAC): 140 AMP
 - 4.5 Technique factors that constitute the max. line current: 300 mA @ 125 kVp.
 - 4.5.1 Generator rating:
 - 4.5.1.1. Output current: 00-300 mA.
 - 4.5.1.2. Output voltage: 40-125 kVp.
 - 4.5.2 Generator duty cycle:
 - 4.5.2.1. 100 mA @ 125 kVp: 4%
 - 4.5.2.2. 300 mA @ 125 kVp: 1%
 - 4.6 Maximum Deviation of technique factors:

The maximum deviation statements provided below are broad and considered "worst case" conditions.

Typical performance will normally be significantly better.

4.6.1 Peak Tube Potential (kVp)

The Maximum Deviation of the Peak Tube Potential during an exposure from its pre-indicated value is + 5 kVp.

4.6.2 Tube Current

The Maximum Deviation of the tube current during an exposure from its pre-indicated value is + 10% of selected value within a kVp range of 50-125 kVp (inclusive), and + 20% of selected value within a kVp range of 40-50 kVp (exclusive).

4.6.3 Exposure Time

The Maximum Deviation of the measured exposure time from its pre-indicated value is ± 1 pulse for selected times within the range of 1/120-1/10 sec. and $\pm 15\%$ of selected times within the range of 7/60-2 sec.

5.0 CLEANING

This system was designed to withstand the sometimes extreme conditions of a busy veterinary practice. In addition to the drip trough and rust-proof table legs, you'll note that there are no grooves or holes to collect debris.

To periodically clean the unit, use a sponge and a non-abrasive cleanser. Knobs on the control panel are removable for this purpose.

This system must be located in a room different from where the processor is located. Failure to observe this could lead to premature corrosion.

6.0 SCHEDULED DEALER MAINTENANCE

The following schedule of maintenance for this system is required for safety of operation, continued ease of use, and continued long life of the product.

The maintenance program should only be performed by authorized service personnel. Frequency of the service should be 30 days after installation and six months thereafter unless indicated otherwise by local codes and regulations.

6.1 X-Ray Generator Maintenance

6.1.1 Verify that all technique selector knobs are mounted solidly.

6.1.2 Verify proper operation of kVp and mAs digital displays.

6.1.3 Verify proper operation of audio and visual x-ray termination.

6.1.4 Verify time, mA, and kVp accuracy.

6.1.5 Examine all electrical connections of the high voltage generator.

6.1.6 Examine oil level of high voltage transformer and refill if fluid level is greater than 3/4" from the top of the lid.

6.1.7 Examine the high voltage cable ends for carbon tracking.

6.1.8 Examine inside of power supply box for any possible fluid leakage.

6.2 X-Ray Tube Housing

6.2.1 Inspect for possible oil leakage.

6.2.2 Assure that the housing is tightly fastened to the tube mount and collimator.

6.2.3 Inspect stator cable for fraying or damage.

-
-
- 6.2.4 Inspect high voltage cable ends for carbon tracking. Clean and regrease HV Cable ends.
 - 6.3 Collimator
 - 6.3.1 Verify accuracy of field size.
 - 6.3.2 Verify accuracy of light field to x-ray field alignment.
 - 6.3.3 Check lamp on-off switch for proper operation.
 - 6.3.4 Inspect collimator cable for fraying or damage.
 - 6.4 Tubestand
 - 6.4.1 Verify set-screws are securely holding the tube arm.
 - 6.4.2 Inspect counterweight cables for fraying or damage.
 - 6.4.3 Inspect all tubestand movements for binding or interferences.
 - 6.5 Other
 - Inspect high voltage cable and all other cabling for damage.

7.0 TROUBLESHOOTING

7.1 Error Message

Upon error detection, the unit will display one of the following error codes:

FOOT	Early release of the exposure foot switch during exposure. Films are likely to turn out light. Foot must be depressed for the entire selected exposure time.
TUBE	Single shot tube power limits were exceeded by the selection technique. Reduce kVp, mA and / or time (PREP and EXPOSE locked out). Message clears when the techniques change.
HEAT	Tube heat exceeded. PREP and EXPOSE locked out until technique reduced or tube cools down.
ROTR	Tube rotor error. Call for service.
ZCO	Equipment component (hardware) error. Call for service.

-
-
- ZZZZ** (Power saver mode only.) Unit will go to sleep within 5 minutes.
- FIL1-FIL4** Hardware error. Call for service.
- COLD** The unit needs to warm up for best output accuracy, but exposures can be taken if needed. This display should clear about ten minutes after first turn on of the day.

7.2 No Exposure

If, after fully depressing the foot switch, there is no audible tone, your unit may not be turned on. Use the circuit breaker to turn on power. If there is still no exposure, call a service representative.

7.3 Collimator light bulb burned out.

When the collimator light bulb burns out, you may either call a service person for replacement/realignment or may choose to replace the bulb yourself.

The replacement bulb must be FCS type; 150 Watt at 24 V with a pin base.

WARNING #1:

DO NOT LOOK DIRECTLY INTO THE COLLIMATOR LIGHT SOURCE AS RETINA DAMAGE COULD RESULT.

WARNING #2:

TURN THE CIRCUIT BREAKER OFF BEFORE ATTEMPTING BULB REPLACEMENT TO AVOID POSSIBLE ELECTRIC SHOCK.

First, remove the back cover of the collimator. The bulb is now visible.

WARNING #3:

THE BULB, WHEN LIT, GETS VERY HOT. ALLOW IT TO COOL SEVERAL MINUTES TO AVOID BURNING YOUR FINGERS.

Pull the bulb straight out from the ceramic base.

WARNING #4:

DO NOT MAKE DIRECT CONTACT WITH THE REPLACEMENT BULB AS OIL FROM YOUR FINGERS WILL CREATE HOT SPOTS ON THE BULB WHICH SUBSEQUENTLY MAY LEAD TO CRACKING.

To avoid direct contact between bulb and fingers, the replacement bulb is normally packaged in a cellophane wrapper. Tear open one end so that prongs are exposed; hold the glass portion, still in its wrapper, and insert the prongs into the ceramic base. Make sure that each prong is securely fastened into its socket so that the resulting light field is straight. Replace the back cover.

If the light field is out of alignment with the grid cabinet, call an authorized service representative for re-alignment.

7.4 No digital display

If, after turning on the circuit breaker, digital displays do not light up, this indicates lost power. The source may be a blown fuse within the unit or a problem with incoming line power. Call an authorized service representative.

7.5 Circuit tripping

If the circuit breaker shuts off on its own, this indicates mA overload. This could be due to miscalibration of the mA or another malfunction.

In the event that the unit is miscalibrated, you may still be able to operate the unit by moving to 100 mA. This will allow you to take X-Rays until a service representative is called.

7.6 Full kVp range inaccessible.

If this occurs, it means that incoming line voltage is too low. Call an authorized service representative to correct.

7.7 Poor film quality

There are many interrelated factors in the radiographic process which impact the degree of darkening visible on a film. The following is a list of items to check whenever you notice a significant change in film quality:

-
-
- 7.7.1 Film Processing - Has chemistry been changed recently? Is a new brand/type being used? Have developing temperatures varied? All of these affect film quality.
 - 7.7.2 Technique - Were proper technique factors used? Consult with an x-ray dealer for information on setting up a technique chart.
 - 7.7.3 Screens/Cassettes - Screens within the cassettes degrade over time. They typically lose 10% of their light-emitting capability per year. It is recommended that cassettes be re-screened every five to seven years. All screens should be replaced at one time to maintain uniform exposure.
 - 7.7.4 Film - Has a new brand/type/speed of film been used? Is the film beyond its expiration date? If so, new film may be purchased or technique factors may need adjustment.
 - 7.7.5 Foot switch - If thorax/chest films are blurring more than usual, it could be that the exposure switch is being used incorrectly. See section 4.5 to review how to make exposures.

8.0 WARRANTY NOTICE

This system is warranted as follows: any Summit manufactured part proving defective will be repaired or replaced free of charge, F.O.B. factory, if the defective part is returned for inspection, freight charges prepaid. This warranty covers parts only and does not include any on-sight labor costs.

This warranty is five years from the date of installation.

This warranty does not apply to collimator glassware or x-ray tubes or damage caused by accident, misuse, neglect, or shipment, and is void if service is performed by persons other than those authorized by Summit or if equipment is interconnected with components not approved by Summit for compatibility.

The x-ray tube manufacturer's warranty is one year, pro-rated. Summit will extend this warranty to five years, pro-rated on manufacturer's list price at time of claim, provided the tube is purchased and used exclusively with this system.

Please call your dealer to coordinate the return of a warranty part or call Summit direct at 1-800-972-9776.