

Technical Publication
CA-1036R2

Calibration

HF Series Generators

REVISION HISTORY

REVISION	DATE	REASON FOR CHANGE
0	JAN 23, 2004	First edition
1	APR 1, 2005	Documentation upgrade
2	FEB 29, 2007	Calibration of optional 1000 mA station

This Document is the english original version, edited and supplied by the manufacturer.

The Revision state of this Document is indicated in the code number shown at the bottom of this page.

ADVISORY SYMBOLS

The following advisory symbols will be used throughout this manual. Their application and meaning are described below.



DANGERS ADVISE OF CONDITIONS OR SITUATIONS THAT IF NOT HEHEDED OR AVOIDED WILL CAUSE SERIOUS PERSONAL INJURY OR DEATH.



ADVISE OF CONDITIONS OR SITUATIONS THAT IF NOT HEHEDED OR AVOIDED COULD CAUSE SERIOUS PERSONAL INJURY, OR CATASTROPHIC DAMAGE OF EQUIPMENT OR DATA.



Advise of conditions or situations that if not heeded or avoided could cause personal injury or damage to equipment or data.

Note 

Alert readers to pertinent facts and conditions. Notes represent information that is important to know but which do not necessarily relate to possible injury or damage to equipment.

Section	Page
2.7 Fluoro Calibration	46
2.8 ABC Calibration	50
2.8.1 ABC System with PhotoMultiplier Tube	50
2.8.2 ABC System with TV Camera	55
2.8.2.1 ABC System Adjustment with ABC Signal from TV Camera Compatible with the Generator	57
2.8.2.2 ABC System Adjustment with ABC Signal from TV Camera not Compatible with the Generator	59
2.8.2.3 ABC System Adjustment with no ABC Signal from TV Camera	61
2.9 Final Checks	64

SECTION 1

INTRODUCTION

This Calibration document provides information and procedures to perform all the adjustments required to establish an optimal performance of this Generator.



Calibrate the Generator immediately after Configuration is completed.



DO NOT SUPPLY THE MAIN POWER UNTIL SPECIFICALLY INSTRUCTED TO DO SO IN THIS DOCUMENT.

THE MAIN CAPACITORS OF THE HIGH VOLTAGE INVERTER RETAIN A LARGE PORTION OF THEIR CHARGE FOR APPROX. 3 MINUTES AFTER THE UNIT IS TURNED OFF.

Calibration data is entered in digital form and stored in a non-volatile memory chip (U3-EEPROM) located on the HT Controller Board, thus no battery back-up is required.

Note 

Calibration procedures must be performed in the order listed in this document. Perform only the sections required to calibrate this unit.

1.1 GENERATOR SPECIFICATIONS

1.1.1 MINIMUM CURRENT TIME PRODUCT (mAs)

- Minimum Current Time Product obtained at 0.1 s is 1 mAs.
- Minimum Current Time Product within the specified ranges of compliance for linearity and constancy is 0.1 mAs.

1.1.2 ACCURACY OF RADIOGRAPHIC AND FLUOROSCOPIC PARAMETERS

Note 

Specified accuracy does not include test equipment accuracy.

PARAMETERS		ACCURACY (with 12 BITS HT Controller)
RAD	kV	$\pm (3\% + 1 \text{ kV})$
	mA	$\pm (4\% + 1 \text{ mA})$
	Exposure Time	$\pm (2\% + 0.1 \text{ ms})$
FLUORO	kV	$\pm (3\% + 1 \text{ kV})$
	mA	$\pm 10\%$
	Exposure Time	$\pm (1\% + 20 \text{ ms})$

1.1.3 HV FREQUENCY

The operating HV Frequency of this Generator is 25 kHz / 30 kHz.

1.1.4 DUTY CYCLE

The Generator duty cycle is continuous, but limits should be set during installation depending on the capacity of the X-ray tube.

SECTION 2 CALIBRATION PROCEDURES

Note 

Enter in GSM Program for Calibration procedures as described in the "Configuration" document.

Enter and store calibration data in the Extended Memory Locations as described in Section 2.2 of the "Configuration" document.

Record all the calibration data in the Data Book.

Before calibration, bear in mind that:

- For calibration and measure the kVp it is needed a Non-Invasive kVp Meter.
- For calibration and measure mA or mAs it is needed a mAs Meter plugged to the banana connections on the HV Transformer (connect the mAs Meter for Digital mA Loops calibration).

Note 

*Test points on the HT Controller Board can also be used to monitor the kV and mA readings but **should not be used** to calibrate the unit. These test points must be checked with scope:*

- mA test point is TP-5 and the scale factor is:

**with HT Controller Board A3000-xx (except -44)
(<1000 mA Generator)**

- from 10 to 80 mA, 1 volt = 10 mA
- from 100 mA, 1 volt = 100 mA

with HT Controller Board A3000-44 (1000 mA Generator)

- from 10 to 80 mA, 1 volt = 20 mA
- from 100 mA, 1 volt = 200 mA

**- kV test point is TP-7 and the scale factor is 1 volt = 33.3 kV
(0.3 volt = 10 kV)**

- Verify that dip switch 3024SW2-3 on the ATP Console CPU Board is in "**On**" position to permit the service mode.

- Verify position of dip switches on the HT Controller Board during every calibration procedure:

DIP SWITCH	OPEN (OFF)	CLOSED (ON)
3000SW2-2	Position during operation - Enables Filament and Rotor Interlocks	Disables Filament and Rotor Interlocks (this turns off the filament so no radiation will be produced during the exposure).
3000SW2-4	Position during operation - Digital mA Loop Closed	Digital mA Loop Open / Filament Current Constant

Note 

Only for Generators with Low Speed Starter (LF-RAC) (it does not apply to Generators with High Speed Starter - LV-DRAC):

- When the Digital mA Loop is open (dip switch 3000SW2-4 in "On"), the rotor runs for two minutes after releasing the handswitch button from "Preparation" position. After this time the rotor will brake (unless DC Brake is removed).

- When the Digital mA Loop is closed (dip switch 3000SW2-4 in "Off"), the rotor will brake after releasing the handswitch button from "Preparation" position (unless DC Brake is removed).

- Be sure that X-ray Tubes configured in E02 and E18 Memory Locations correspond to X-ray Tubes installed (refer to Configuration document).

2.1 FILAMENT STAND-BY CURRENT

Note 

For RAD Only Generators, the Filament Stand-by value is auto-calibrated by the Generator and automatically stored into the respective Memory Locations (E01 and E17). Filament Stand-by values are not field changeable.

Note 

For RAD and Fluoro Generators, E17 Memory Location ("Fluoro Filament Setting") sets maximum patient Entrance Skin Exposure Dose Rate. (Refer to Section 2.7 "Fluoro Calibration").

2.2 EXPOSURE TIME ADJUSTMENT

The values stored in these Extended Memory Locations only affect to Exposure Times for techniques below 20 ms. The Memory Locations which affect short exposure times are:

FUNCTION	MEMORY LOCATION	
	TUBE-1	TUBE-2
EXPOSURE TIME ADJUSTMENT - DELAY	E13	E29
EXPOSURE TIME ADJUSTMENT - Ceq kV	E15	E31

The generator has been optimized at the factory to produce correct exposures at the lower times (<20 ms.) Therefore **do not change** the value factory set for E13 and E29 Memory Locations and only adjust the value for E15 and E31 Memory Location according to the HV Cables length.

The Exposure Time adjustment is calibrated by performing the following steps:

1. Enter in calibration mode by pressing the “Manual Calibration” button on the GSM Program. Select an available workstation (WS) and press the “OK” button.
2. Select the E13 (or E29) Memory Location. Value in this Memory Location adjusts the time delay of the exposure. It is factory set for a value of 17, 18 or 19 (*default value is “18”*). Only read this value, **do not change it**.
3. Select the E15 (or 31) Memory Location. Value in this Memory Location is set in relation to the length in meters of one of the HV Cables (1 ft = 0.3048 m). Verify the HV Cable length in meters and set the following value:

HV CABLE LENGTH	VALUE TO SET IN MEMORY
4 m	27
6 m	31
9 m	38
12 m	45
14 m	49
16 m	54
For another HV Cable length	value = (2.2711 x cables length) + 17.744

4. Store the value of each Memory Location by pressing the “Store” button of the calibration panel.
5. Exit from calibration mode and record the new values in the Data Book.
6. Repeat the above calibration process for the second tube (memory locations E29 and E31).

2.3 KV LOOP

Extended Memory Location E06 contains the calibration factor for kV Loop. Each number above or below of the indicated in the E06 memory location increases or decreases respectively the kV gain value.

Note

*Value in E06 Memory Location is only related to the Generator performance (it is not related to the X-ray Tube(s) or another components installed), so value in **this Memory Location is factory adjusted**. Only perform this procedure if the HT Controller Board and/or HV Transformer have been replaced in the unit.*

The kV Gain for kV Loop can be manually calibrated with a Non-Invasive kV Meter (recommended procedure) or Auto-calibrated with HV Bleeder.

Manual Calibration of E06 Memory Location

1. With the Generator power OFF:
 - Set Dip switch 3000SW2-2 on the HT Controller Board in “**Off**” position (enables Filament and Rotor Interlocks).
 - Set Dip switch 3000SW2-4 on the HT Controller Board in “**On**” position (Digital mA Loop Open / Filament Current Constant).
 - Remove the link between the banana plug connections on the HV Transformer. Connect the mAs Meter to the banana plug connections to measure mA or mAs.
 - Place and center a Non-Invasive kVp Meter on the X-ray Tube output at the required SID (*refer to the Non-Invasive kVp Meter documentation*).
2. Enter in calibration mode by pressing the “*Manual Calibration*” button on the GSM Program. Select an available workstation (WS) and press the “OK” button.
3. Select the E06 Memory Location and read the calibration value by pressing the “*Read*” button. Enter the value “**200**” and store it by pressing the “*Store*” button.

4. Calibrate manually the Filament Current Number for 80 kV / 200 mA combination, as indicated in the following steps (*if it has not been previously calibrated*).

In calibration mode, Filament Current Numbers are shown on the calibration panel by pressing the “Read” button after selecting the respective kV / mA combination. They can be changed by pressing the “Increase” and “Decrease” buttons and stored by pressing the “Store” button of the calibration panel.

Select 80 kV, 200 mA, Large Focus. Enter the value “344” as Filament Current Number (calibration value) and press the “Store” button. Make an exposure with these parameters. The mAs read on the mAs Meter must be the same mAs displayed on the calibration screen with a tolerance of ± 0.1 mAs (tolerance of the parameter and mAs Meter).

If the mAs is low, increase the filament number. If the mA is high (or “Generator Overload” Error is shown), decrease the filament number. Press the “Store” button before making a new exposure. Repeat until the mAs read is correct and the mA station is calibrated.

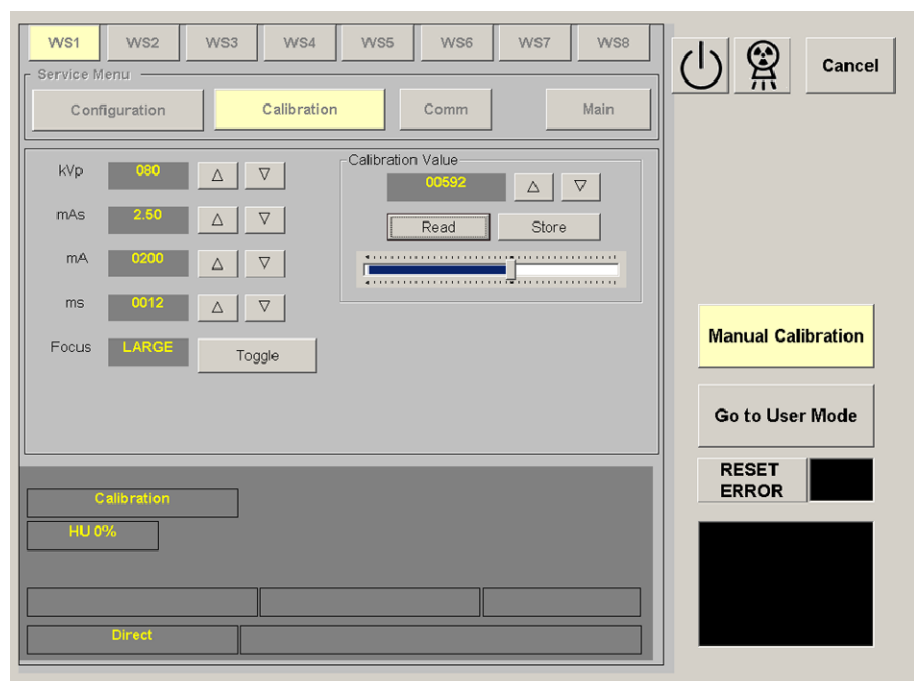

5. Enter in user mode inside calibration mode by pressing the “Go to User Mode” button.
6. Select: RAD Menu, 80 kV, 200 mA, 100 ms and Large Focus. Make an exposure and note the kV value at the end of the exposure.

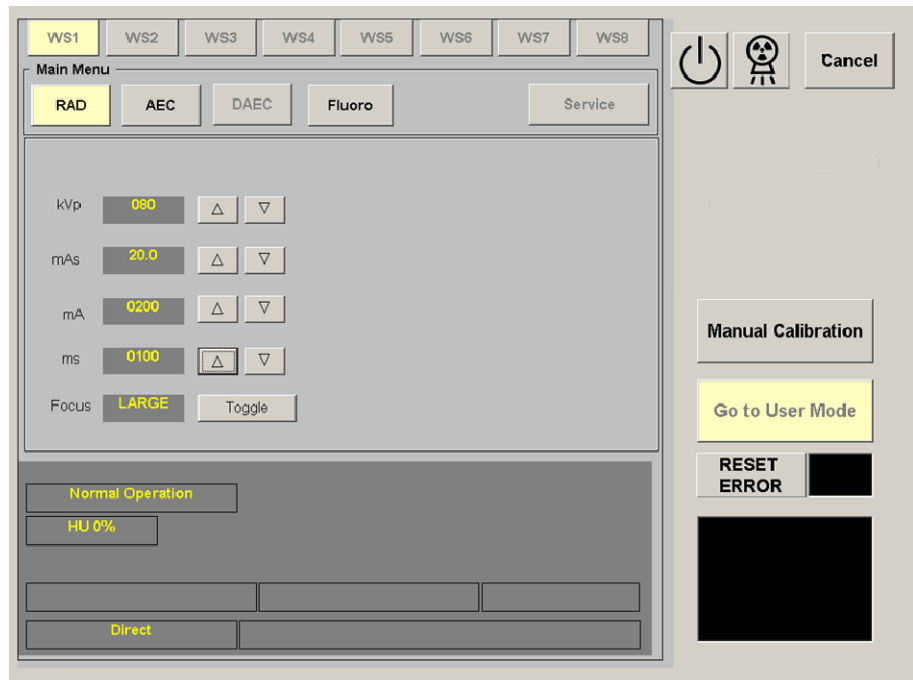

7. If calibration of the kV Loop is correct (80 ± 1 kV), record value “200” in the Data Book.
8. If calibration of the kV Loop is not correct:
 - a. Exit from the “User Mode” screen by pressing the “Manual Calibration” button. Select the E06 Memory Location. Press the “Read” button to read the value stored.
 - b. Increase or decrease the value to increase or decrease the kV respectively. Enter the new value and store it by pressing the “Store” button.
 - c. Exit calibration mode and repeat the exposure (steps 5 and 6) to determine if the new value has had the proper effect, if not repeat step-8.
 - d. When it is correct, record the new value for E06 Memory Location in the Data Book.
9. After calibration of E06 Memory Location, remove the Non-Invasive kVp Meter.

Auto-Calibration of E06 Memory Location

1. With the Generator power OFF:
 - Set Dip switch 3000SW2-2 on the HT Controller Board in “**On**” position (disables Filament and Rotor Interlocks).
 - Remove the HV Cables from the X-ray Tube and connect them to the HV Bleeder, then connect a short couple of HV Cables from the HV Bleeder to the X-ray Tube.

2. Enter in Auto-calibration mode by pressing the “*Auto Calibration*” button on the GSM menu. Select an available workstation (WS) and press the “*OK*” button. Then, select the E06 Memory Location and press the “*OK*” button.

Confirm or leave the Auto-calibration by pressing the respective button (“*Yes*” or “*No*”) on the new screen.

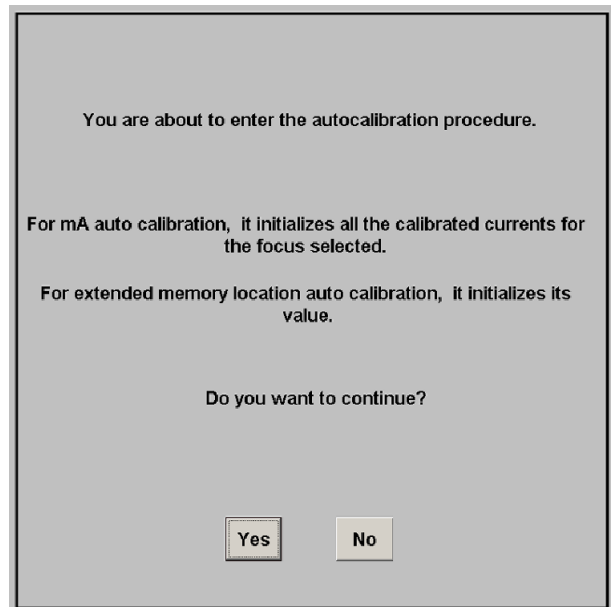
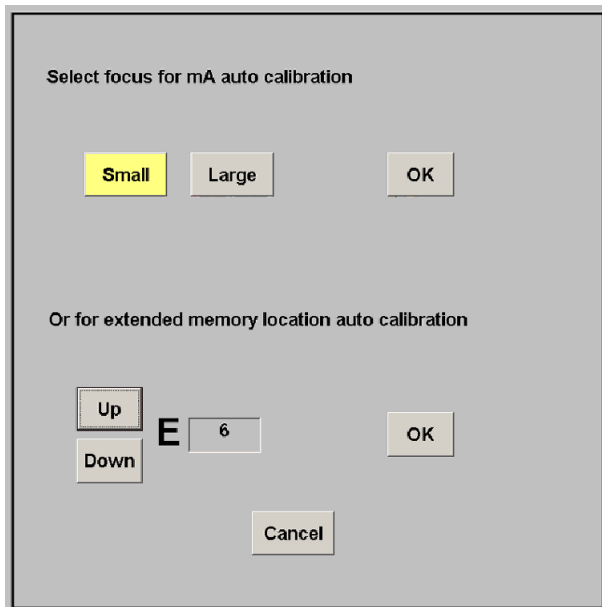

Confirm or leave the Auto-calibration (second confirmation) by pressing the respective button (“*Confirm*” or “*Dismiss*”) on the calibration screen.

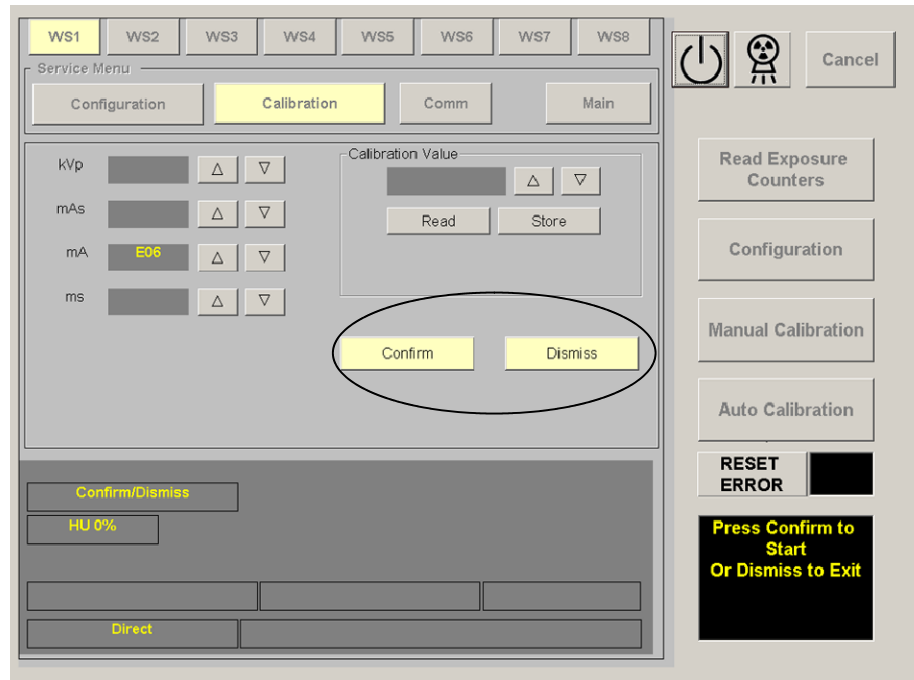

Auto-calibration is activated when the “*Auto Calibration*” button is lighted and the “*Press Prep and Expose*” message appears on the screen.

3. Make an exposure (technique parameters are pre-programmed at 100 kV, 200 mA and 32 ms and they can be shown when pressing the “*Prep*” button).
4. Read the kVp measured with the HV Bleeder and enter this value on the kV Display by pressing the “*kV Increase*” or “*kV Decrease*” buttons.
5. Exit from Auto-calibration mode pressing the “*Auto Calibration*” button. At this moment, the Generator will calculate and store the new value in E06 Memory Location. Auto-calibration is deactivated and the process is finished when the screen shows the GSM menu.
6. Press the “*Manual Calibration*” button. Select an available workstation (WS) and press the “*OK*” button. Then, select the E06 Memory Location and read its new value on the Calibration Display. Record this value in the Data Book.
7. Exit calibration mode.
8. After calibration of E06 Memory Location:
 - Switch the Generator power OFF.
 - Remove the HV Bleeder and connect the HV Cables from the Generator directly to the X-ray Tube.

2.4 DIGITAL mA LOOP CLOSED

Extended Memory Locations E03 and E05 contain the calibration factor for Digital mA Loop Closed. Each number above or below the indicated in the Memory Locations increases or decreases respectively the mA gain value.

Note 

*Values in E03 and E05 Memory Locations are only related to the Generator performance (they are not related to the X-ray Tube installed), so values in **these Memory Locations are factory adjusted**. Only perform this procedure if the HT Controller Board and/or HV Transformer have been replaced in the unit.*

The mA Gain for Digital mA Loop Closed is calibrated by performing the following steps:

1. With the Generator power OFF, set:
 - Dip switch 3000SW2-2 on the HT Controller Board in “**Off**” position (enables Filament and Rotor Interlocks).
 - Dip switch 3000SW2-4 on the HT Controller Board in “**On**” position (Digital mA Loop Open / Filament Current Constant).
 - Remove the link between the banana plug connections on the HV Transformer. Connect the mAs Meter to the banana plug connections to measure mA or mAs.
2. Calibration of E03 and E05 Memory Locations is performed by means of the “*Auto Calibration*” menu.



EACH TIME THAT AUTO-CALIBRATION IS ACTIVATED IN ONE OF THESE MEMORY LOCATIONS, CALIBRATION DATA STORED FOR THIS MEMORY LOCATION IS DELETED AND A NEW CALIBRATION FOR IT WILL BE REQUIRED.

3. Enter in Auto-calibration mode by pressing the “Auto Calibration” button on the GSM menu. Select an available workstation (WS) and press the “OK” button. Then, select the respective Memory Location (E03 or E05) and press the “OK” button.

Confirm or leave the Auto-calibration by pressing the respective button (“Yes” or “No”) on the new screen.

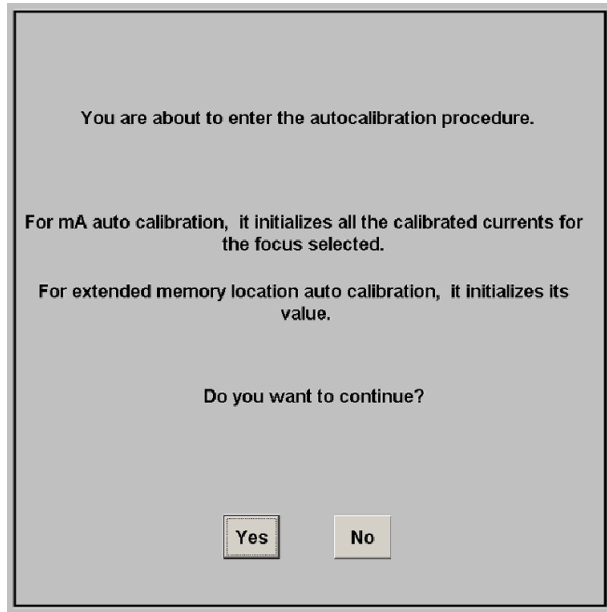
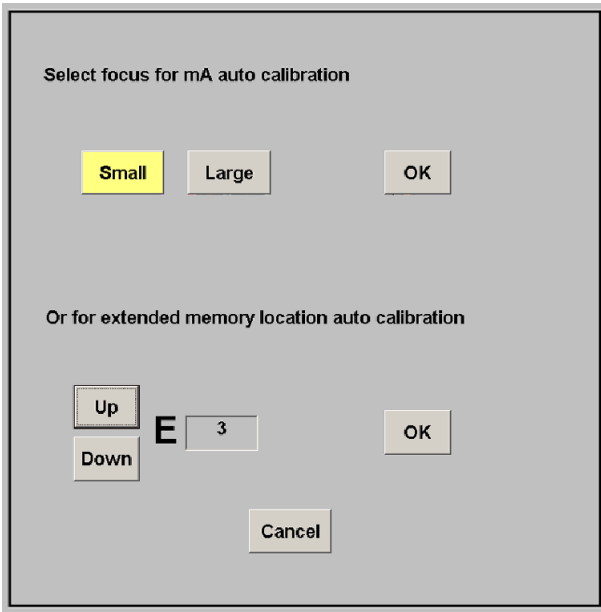

Confirm or leave the Auto-calibration (second confirmation) by pressing the respective button (“Confirm” or “Dismiss”) on the calibration screen.

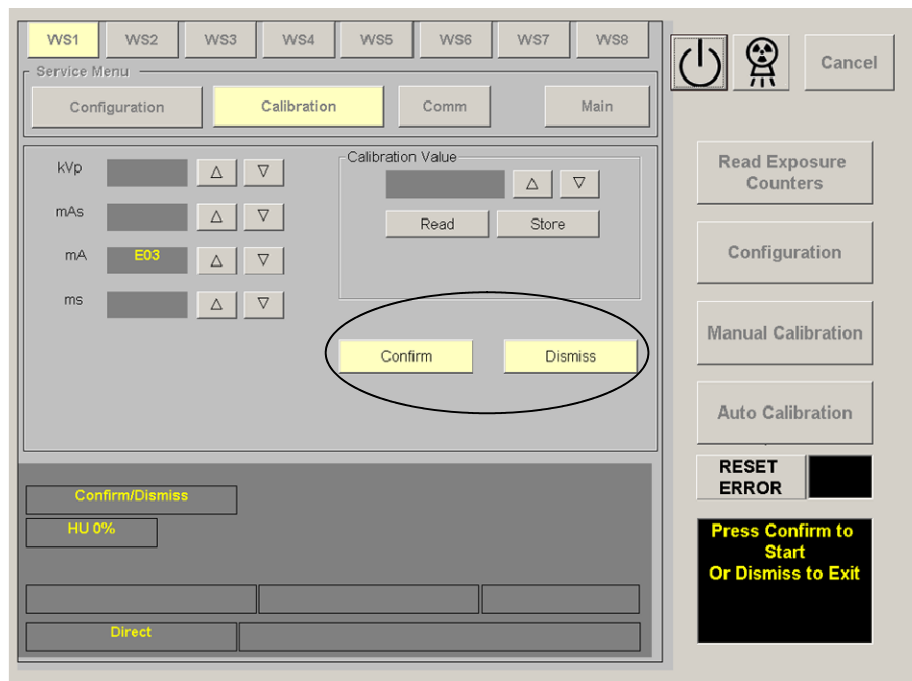

Auto-calibration is activated when the “Auto Calibration” button is lighted and the “Press Prep and Expose” message appears on the screen.

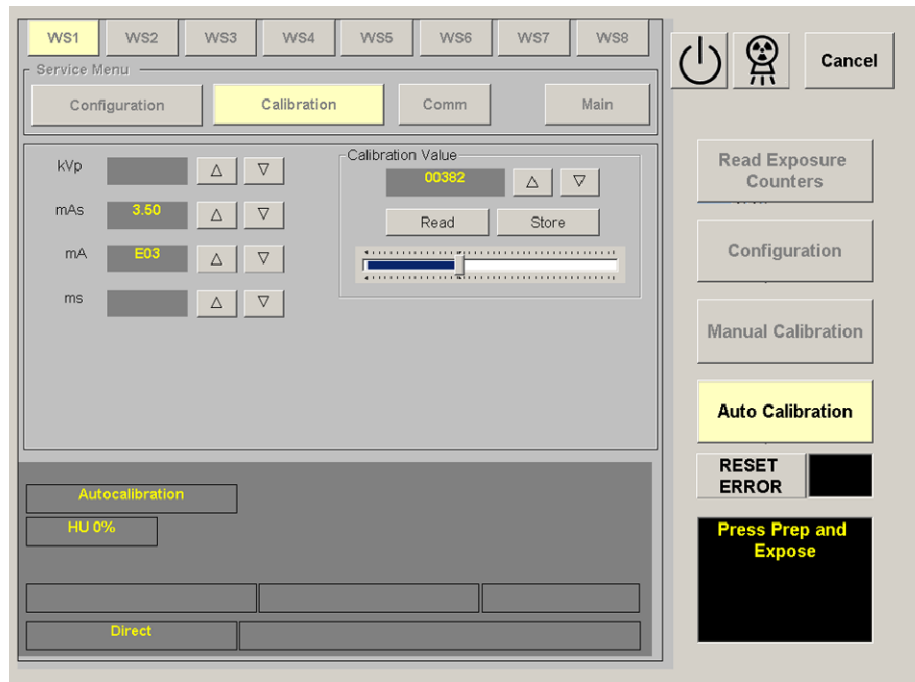

4. Calibrate E03 and E05 Memory Locations as described in the following pages.

For Low mA stations (from 10 mA to 80 mA) (E03 Memory Location):

1. Enter in Auto-calibration mode by pressing the “*Auto Calibration*” button on the GSM menu and select the E03 Memory Location. Confirm all the following screens.
2. When Auto-calibration is activated, “*Auto Calibration*” button is lighted and the mAs value is shown on the screen (3.5 mAs or 35 mAs depending on the Generator software).
3. Perform the following steps:
 - a. Make an exposure (technique parameters are pre-programmed at 80 kV, 32 mA and the respective time (0.1 s or 1 s) and they can be shown when pressing the “*Prep*” button).
 - b. Read the mAs measured on the mAs Meter.
 - c. Read the Filament Current Number shown on the calibration panel.
 - d. Increase or decrease the Filament Current Number (by pressing the “*Increase*” or “*Decrease*” buttons) to determine the correction needed to obtain a value between 3.0 and 4.0 mAs (for 3.5 mAs) or a value between 30 and 40 mAs (for 35 mAs) in the mAs Meter after making a new exposure.
 - e. Repeat the above steps until a proper mAs value is obtained in the mAs Meter.
4. Enter the mAs value read in the mAs Meter (step 3.) in the mAs Display pressing the “*mAs Increase*” or “*mAs Decrease*” buttons.
5. Exit from Auto-calibration mode pressing the “*Auto Calibration*” button. At this moment, the Generator will calculate and store the new value in E03 Memory Location. Auto-calibration is deactivated and the process is finished when the screen shows the GSM menu.
6. Press the “*Manual Calibration*” button. Select an available workstation (WS) and press the “*OK*” button. Then, select the E03 Memory Location and read its new value on the Calibration Display. Record this value in the Data Book.
7. Exit calibration mode.

For High mA stations (from 100 mA) (E05 Memory Location):

1. Enter in Auto-calibration mode by pressing the “*Auto Calibration*” button on the GSM menu and select the E05 Memory Location. Confirm all the following screens.
2. When Auto-calibration is activated, “*Auto Calibration*” button is lighted and the mAs value is shown on the screen (7.75 mAs or 77.5 mAs depending on the Generator software).
3. Perform the following steps:
 - a. Make an exposure (technique parameters are pre-programmed at 80 kV, 125 mA and the respective time and they can be shown when pressing the “*Prep*” button).
 - b. Read the mAs measured on the mAs Meter.
 - c. Read the Filament Current Number shown on the calibration panel.
 - d. Increase or decrease the Filament Current Number (by pressing the “*Increase*” or “*Decrease*” buttons) to determine the correction needed to obtain a value between 7.00 and 8.50 mAs (for 7.75 mAs) or a value between 70 and 85 mAs (for 77.5 mAs) in the mAs Meter after making a new exposure.
 - e. Repeat the above steps until a proper mAs value is obtained in the mAs Meter.
4. Enter the mAs value read in the mAs Meter (step 3.) in the mAs Display pressing the “*mAs Increase*” or “*mAs Decrease*” buttons.
5. Exit from Auto-calibration mode pressing the “*Auto Calibration*” button. At this moment, the Generator will calculate and store the new value in E05 Memory Location. Auto-calibration is deactivated and the process is finished when the screen shows the GSM menu.
6. Press the “*Manual Calibration*” button. Select an available workstation (WS) and press the “*OK*” button. Then, select the E05 Memory Location and read its new value on the Calibration Display. Record this value in the Data Book.
7. Exit calibration mode.
8. After calibration of E03 and E05 Memory Locations:
 - Switch the Generator power OFF.
 - Disconnect the mAs Meter to the banana plug connections.
 - Re-install the link between the banana plug connections on the HV Transformer.

2.5 DIGITAL mA LOOP OPEN (X-RAY TUBE CALIBRATION)

To achieve the most accurate calibration, **this procedure has to be automatically performed by the Generator (Auto-calibration)**. Calibration procedure will be manually performed by the field engineer only if Auto-calibration is not possible.

Two different methods are described in this section: Auto-calibration and Manual Calibration.

Digital mA Loop Open is calibrated by performing the following steps:

1. With the Generator power OFF, set:
 - Dip switch 3000SW2-2 on the HT Controller Board in “**Off**” position (enables Filament and Rotor Interlocks).
 - Dip switch 3000SW2-4 on the HT Controller Board in “**On**” position (Digital mA Loop Open / Filament Current Constant).
2. Turn the Generator ON.
3. Perform the Auto-calibration procedure as described in Section 2.5.1 for each X-ray Tube in the system.

2.5.1 AUTO-CALIBRATION OF DIGITAL mA LOOP OPEN

Auto-calibration of the Filament Current Numbers is divided in two separated procedures related to the mA stations configured for the Small or Large Focal Spots.

It is recommended to start with the Small Focal Spot (first group) and continue with the Large Focal Spot (second group).



EACH TIME THAT AUTO-CALIBRATION IS ACTIVATED IN A mA STATION (OR IN “E01” MEMORY LOCATION), ALL THE FILAMENT CURRENT NUMBERS OF THE SELECTED FOCAL SPOT ARE AUTOMATICALLY SET TO “344”. SO A NEW COMPLETE CALIBRATION OF THE FILAMENT CURRENT NUMBERS FOR THIS FOCAL SPOT WILL BE REQUIRED.

Auto-calibration starts with the minimum available mA station for the selected Focal Spot at 50 kV and follows with the other combinations of mA stations for the selected Focal Spot at 80 kV, 120 kV and 40 kV.

1. Enter in Auto-calibration mode by pressing the “*Auto Calibration*” button on the GSM menu.
2. Select an available workstation (WS) of the X-ray Tube to be calibrated and press the “*OK*” button. This workstation has to be one of the previously configured as “*Direct*”.
3. Select the **Small Focal Spot** by pressing the “*Small*” button and then press the “*OK*” button.

Confirm or leave the Auto-calibration by pressing the respective button (“*Yes*” or “*No*”) on the new screen.

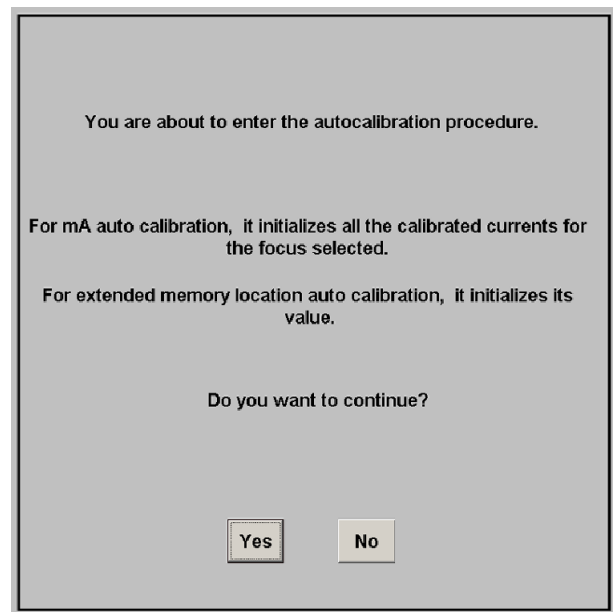
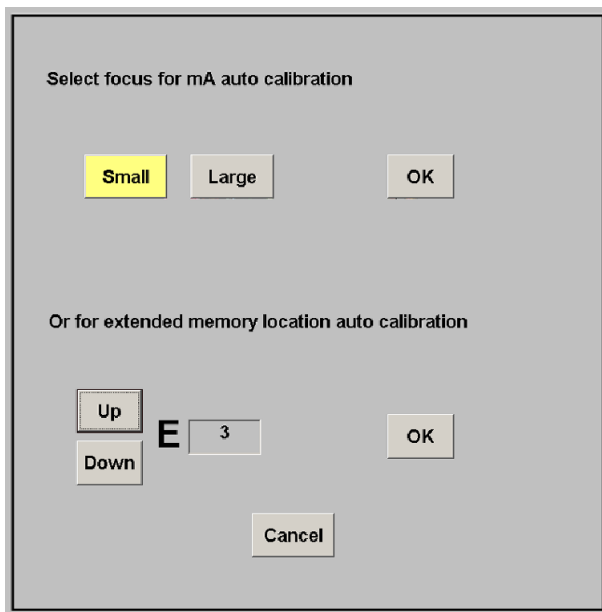

- 4. Confirm or leave the Auto-calibration (second confirmation) by pressing the respective button (“Confirm” or “Dismiss”) on the calibration screen.

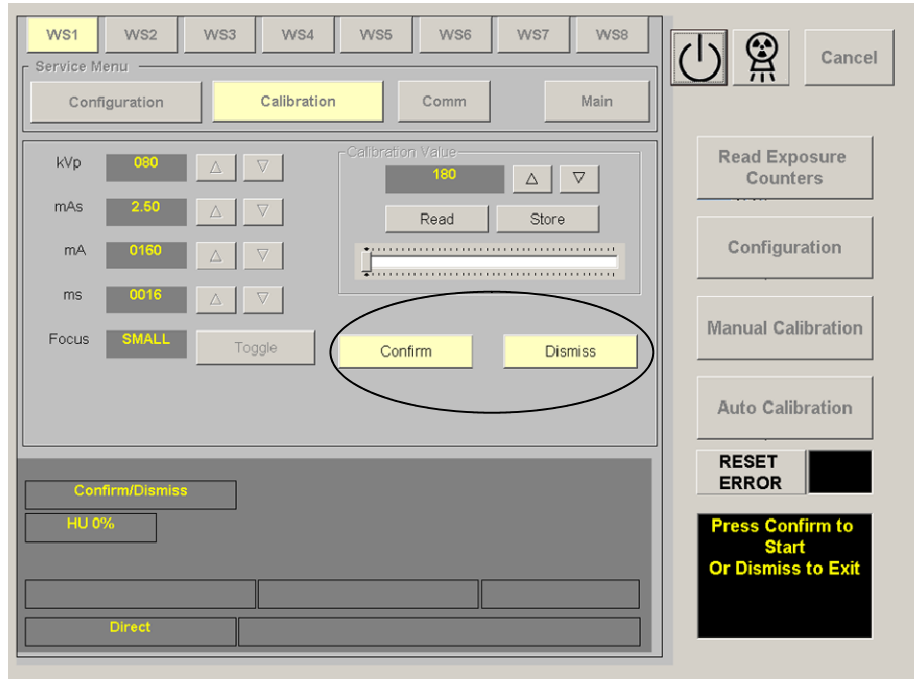

- 5. Auto-calibration is activated when the “Auto Calibration” button is lighted and the “Press Prep and Expose” message appears on the screen. At this moment, the Generator has checked the mA stations available for the **Small Focal Spot**.

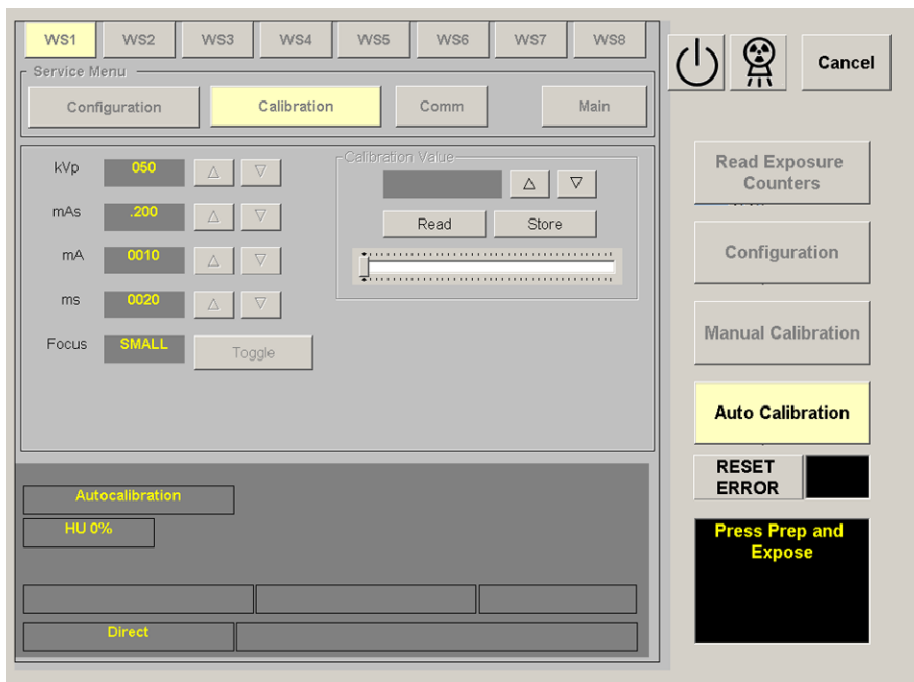

6. Check that the Heat Units capacity available for the X-ray Tube is 100% or nearly (HU 0% displayed on the screen).



BEFORE MAKING ANY EXPOSURE IN AUTO-CALIBRATION, VERIFY THAT THE LINK BETWEEN THE BANANA PLUG CONNECTIONS ON THE HV TRANSFORMER IS INSTALLED.

7. Keep fully pressed the Handswitch button to perform continuous exposures.

Note 

In Auto-calibration mode, all technique parameters are factory pre-programmed and they can not be changed.



Auto-calibration can be paused momentarily releasing the Handswitch button, whenever there is not an exposure in process. Do not exit from Auto-calibration before the procedure has been completed.

Note 

Auto-calibration can be cancelled by pressing the "Auto Calibration" button. A message on the screen informs that Auto-calibration has been cancelled and after a while the screen shows the GSM menu.

If during Auto-calibration process, any error indication is shown momentarily (such as "Tube Overload", etc.), it means that Generator can not calibrate in this moment the selected kV / mA combination (because anode overheated, space charge, Generator power limit, etc.). In this case, the Generator will continue with Auto-calibration of the following available kV / mA combinations for the selected Focal Spot. At the end of the process it will try to calibrate or calculate the combinations previously uncalibrated.

If the Heat Units value displayed is more than 60%, exposures are inhibited momentarily and message "Tube too hot" is shown on the screen. This message will disappear and exposures can be made again when the X-ray Tube begins to cool and recovers the Heat Units capacity.

At this point, it is recommended to wait until the Heat Units value displayed are close to the 20% before making any exposure.

Generator tries to calibrate each kV / mA combination for ten (10) attempts (maximum). If calibration is cancelled (after ten attempts), message “*Auto calibration failure*” is shown on the screen until press the “*Auto Calibration*” button to exit from Auto-calibration mode and go back to the GSM menu. Calibration can be also cancelled due to space charge during calibration of the lowest kV at the highest mA stations for the Focal Spot selected, so message “*Auto calibration failure*” is also shown on the screen until press the “*Auto Calibration*” button to exit from Auto-calibration mode and go back to the GSM menu.



ONLY IF AUTO-CALIBRATION IS CANCELLED DUE TO “*AUTO CALIBRATION FAILURE*”, CONTINUE THE AUTO-CALIBRATION PROCEDURE FOR THE OTHER FOCAL SPOT. CHECK AT THE END OF THE AUTO-CALIBRATION PROCEDURE WHICH kV / mA COMBINATIONS HAVE NOT BEEN AUTO-CALIBRATED FOR EACH FOCAL SPOT (THESE COMBINATIONS HAVE THE FILAMENT CURRENT NUMBER SET TO “344”). MANUALLY CALIBRATE THESE kV / mA COMBINATIONS AS EXPLAIN IN SECTION 2.5.2.

When Auto-calibration is successfully performed, message “*Auto Calibration OK*” is shown on the screen until press the “*Auto Calibration*” button to exit from Auto-calibration mode and go back to the GSM menu.

8. Repeat the same procedure for the **Large Focal Spot**.

Enter in Auto-calibration mode by pressing the “*Auto Calibration*” button on the GSM menu.

Select an available workstation (WS) of the X-ray Tube to be calibrated and press the “*OK*” button. This workstation has to be one of the previously configured as “*Direct*”.

Select the **Large Focal Spot** by pressing the “*Large*” button and then press the “*OK*” button.

Confirm or leave the Auto-calibration by pressing the respective button on each screen.

Auto-calibration is activated when the “*Auto Calibration*” button is lighted. At this moment, the Generator has checked the mA stations available for the **Large Focal Spot**.

Before starting the exposures, it is recommended to wait until the Heat Units value displayed are close to the 20%.

9. After performing both procedures (for Small and Large Focal Spots), enter in "*Manual Calibration*" mode and select each combination of the available mA stations for each Focal Spot at the kV break points (40, 50, 80 and 120 kV). Press the "*Read*" button to read on the calibration panel the new value of the Filament Current Number stored for each combination and record the new values in the Data Book.

Note that the highest mA station for Small Focal Spot may have numbers larger than the lowest mA station for Large Focal Spot. This is normal.

10. Exit from calibration mode.
11. Perform the Auto-calibration procedure for the second X-ray Tube.
12. **Turn the Generator power OFF and set Dip Switch 3000SW2-4 on the HT Controller Board in "*Off*" position (Digital mA Loop Closed).**

2.5.2 MANUAL CALIBRATION OF DIGITAL mA LOOP OPEN

This procedure describes the Manual calibration of all the Filament Current Numbers. It has to be also used to calibrate the kV / mA combinations not performed during Auto-calibration procedure because it has not been completed. These combinations have the Filament Current Number set to "344", so only these combinations have to be manually calibrated as described in this procedure. If Auto-calibration for one of the Focal Spots has been successful, it is only required to perform the manual calibration of the mA station do not calibrate for the other Focal Spot.

Manual Calibration is initiated at the 80 kV break point by entering the appropriate Filament Current Number for the proper tube current at each selectable mA. Calibration at the other kV break points (40, 50, 80 and 120 kV) are obtained by adding or subtracting values as indicated in Table 2-1.

Although the suggested values (Table 2-1) could change depending on the X-ray tube used, entering those values will approximate accurate calibration without making excessive exposures.

In "*Manual Calibration*" mode, the Filament Current Numbers are shown on the calibration panel by pressing the "*Read*" button after selecting the respective kV / mA combination. The value can be changed by pressing the "*Increase*" or "*Decrease*" buttons of the calibration panel and stored by pressing the "*Store*" button.

Note that in calibration mode, only the mA stations and kV (at the break points) can be selected.

HF Series Generators

Calibration

Table 2-1
mA Calibration Numbers Change

mA STATION	FILAMENT CURRENT NUMBERS AT KV BREAK POINT			
	40	50	80	120
10	A ₁ +7	A ₁ +6	A ₁	A ₁ -5
12.5	A ₂ +7	A ₂ +6	A ₂	A ₂ -5
16	A ₃ +7	A ₃ +6	A ₃	A ₃ -5
20	A ₄ +7	A ₄ +6	A ₄	A ₄ -5
25	A ₅ +7	A ₅ +6	A ₅	A ₅ -5
32	A ₆ +7	A ₆ +6	A ₆	A ₆ -5
40	A ₇ +7	A ₇ +6	A ₇	A ₇ -5
50	A ₈ +7	A ₈ +6	A ₈	A ₈ -5
64 (or 63 or 65)	A ₉ +7	A ₉ +6	A ₉	A ₉ -5
80	A ₁₀ +7	A ₁₀ +6	A ₁₀	A ₁₀ -5
100	A ₁₁ +10	A ₁₁ +8	A ₁₁	A ₁₁ -7
125	A ₁₂ +10	A ₁₂ +8	A ₁₂	A ₁₂ -7
160	A ₁₃ +10	A ₁₃ +8	A ₁₃	A ₁₃ -7
200	A ₁₄ +10	A ₁₄ +8	A ₁₄	A ₁₄ -7
250	A ₁₅ +10	A ₁₅ +8	A ₁₅	A ₁₅ -7
320	A ₁₆ +14	A ₁₆ +11	A ₁₆	A ₁₆ -9
400	A ₁₇ +14	A ₁₇ +11	A ₁₇	A ₁₇ -9
500	A ₁₈ +14	A ₁₈ +11	A ₁₈	A ₁₈ -9
640 (or 630 or 650)	A ₁₉ +14	A ₁₉ +11	A ₁₉	A ₁₉ -9
800	A ₂₀ +14	A ₂₀ +11	A ₂₀	A ₂₀ -9
1000	A ₂₁ +14	A ₂₁ +11	A ₂₁	A ₂₁ -9

Note. - The mA station values depends on the Generator model. Some models do not contain all the mA stations listed above.

1. With the Generator power OFF, set:
 - Dip switch 3000SW2-2 on the HT Controller Board in “**Off**” position (enables Filament and Rotor Interlocks).
 - Dip switch 3000SW2-4 on the HT Controller Board in “**On**” position (Digital mA Loop Open / Filament Current Constant).
 - Remove the link between the banana plug connections on the HV Transformer. Connect the mAs Meter to the banana plug connections to measure mA or mAs.
2. Turn the Generator ON and enter in calibration mode by pressing the “*Manual Calibration*” button on the GSM menu.
3. Select an available workstation (WS) of the X-ray Tube to be calibrated and press the “*OK*” button. This workstation has to be one of the previously configured as “*Direct*”.
4. Check that the Heat Units available for the X-ray Tube is 100% or nearly (HU 0% displayed on the screen).
5. Accordingly to X-ray tube ratings or maximum Generator power, check which kV / mA combinations in Table 2-1 are allowed.

If error “*Tube Overload*” is shown after selection of a kV / mA combination, it means this combination is not allowed for the selected X-ray Tube.

In calibration mode, if Generator power is exceeded by a kV / mA combination selection, error “*E-16*” is shown after “*Preparation*”. Reset this error by pressing the “*Reset Error*” button.

Note which combinations in Table 2-1 can not be calibrated by making exposures (combinations not allowed due to Tube rating, maximum Generator power, space charge, etc.) and the Exposure Time assigned to these combinations in calibration mode.

6. Enter in user mode inside calibration mode by pressing the “*Go to User Mode*” button. Select the mA station and Exposure Time of each kV / mA combination not allowed. Increase or decrease the kV value as required to determine the kV value allowed nearest to the kV value of the combination. Note the kV value allowed in the respective cell of Table 2-1.

7. Exit from the “*User Mode*” screen by pressing the “Manual Calibration” button. Select 80 kV and lowest mA station available (first combination available). Enter a Filament Number of “344” for this combination.
8. Make an exposure. The mAs read on the mAs Meter must be the same mAs displayed on the calibration screen with a tolerance of ± 0.1 mAs (tolerance of the parameter and mAs Meter). If the mAs read is close to zero, increase the filament number in big steps (a.e. increase values in 40). As the mAs read is close to the mAs displayed on the Console, increase (or reduce) the filament number in smaller steps (a.e. increase value in 30, 20, 10, ...).

If the mAs is low, increase the filament number. If the mA is high, decrease the filament number. Press the “Store” button before making a new exposure. Repeat until the mA station is calibrated.

Note 

Press the “Store” button to store the new data (filament number) before selecting the next kV or mA stations.



Calibration data (presently in memory) may or may not be close to your requirements. If it is not close, the potential exists to damage the X-ray tube (i.e. too much mA). Thus, as you start the mA calibration procedure note how close or how far off the mA break points are. If a large adjustment (more than 40 points) is required at the low mA stations, make estimated adjustments to the high mA stations before those exposures are made.

9. Select the next mA station at 80 kV. Before making any exposure, enter as filament number the value calibrated for the previous mA station increased in 10.

If the mAs is low, increase the filament number. If the mA is high, decrease the filament number. Press the “Store” button before making a new exposure. Repeat until the mA station is calibrated.

10. Complete the calibration process for all mA stations at 80 kV as described before. When select the first mA station for the Large Focal Spot, enter as a filament number the value calibrated for the first mA station for the Small Focal Spot. Note that the highest mA station for Small Focal Spot may have numbers larger than the lowest mA station for Large Focal Spot. This is normal.

Press the "Read" button to read on the calibration panel the new value of the Filament Current Number stored for each mA station at 80 kV. Record the new values in the Data Book.

Note 

When highest mA stations of the Generator can not be calibrated at 80 kV due to insufficient filament current (the filament current number has reached the maximum number (999)), replace on the Filament Board (A3004-09/10) the Resistor R11 for another resistor with 1.4 k Ω / 5W, and place Jumper JP1 in position "A". Then rename the Filament Board as A3004-11.

ATTENTION: After doing this modification reduce the value of all the filament current numbers (column for 80 kV) at the 25% and perform the calibration procedure again (from step-5).

11. Complete the calibration process for the remaining kV / mA combinations using Table 2-1 as a guide. It is not necessary to make exposures to do this. Compute the value for all the kV break points of each available mA station although the Generator power can not reach all the kV / mA combinations. Select the corresponding kV / mA combination and enter the computed value.
12. Check calibration at all break points (making exposures) and correct any calibration points as needed.

Note 

If "Tube Overload" error is shown directly after selection of an allowed combination (refer to step-5.), wait until the X-ray tube anode cools down to permit the calibration of the mA station.

13. Recalculate the values of the non-allowed combinations in accordance to the new values obtained by exposures. (Refer to Table 2-1).

14. Enter in user mode inside calibration mode by pressing the “*Go to User Mode*” button. Select the mA station, Exposure Time and kV value noted for each kV / mA combination not allowed (*refer to step-6*). Check calibration at these kV / mA combinations by making exposures. If needed, enter in calibration mode and correct the Filament Current Number of the respective kV / mA combination not allowed.

15. Exit from the “*User Mode*” screen by pressing the “Manual Calibration” button. In calibration mode, select each combination of the available mA stations at the kV break points (40, 50, 80 and 120 kV). Press the “*Read*” button to read on the kV Display the new value of the Filament Current Number stored for each combination. Record the new values in the Data Book.

Note that the highest mA station for Small Focal Spot may have numbers larger than the lowest mA station for Large Focal Spot. This is normal.

16. Exit calibration mode.

17. If required, perform the calibration procedure for the second X-ray Tube.

18. After calibration of Filament Current Numbers:
 - Switch the Generator power OFF.
 - Disconnect the mAs Meter to the banana plug connections.
 - Re-install the link between the banana plug connections on the HV Transformer.
 - **Set Dip Switch 3000SW2-4 on the HT Controller Board in “*Off*” position (Digital mA Loop Closed).**

2.6 AEC CALIBRATION

This section describes the adjustments needed to calibrate the AEC according to the customer input. Therefore, AEC exposures will be made during the calibration process in order to insure AEC functionality.

The Optical Density is controlled by the values stored in the respective memory locations. These values are influenced by film speed, screen speed, dark room procedures and customer requirements.

Use a homogeneous Phantom with enough density to produce an exposure of 100 ms, the AEC will be calibrated to produce a density of 1.0 (or the customer preference Optical Density) at 70 kV, and then AEC tracking will be adjusted to produce the same density at 55 kV, 90 kV and 110 kV.

Note 

For AEC calibration with Film, use the same Film and Cassettes used by the customer. AEC calibration must be performed using the Medium Film/Screen speed combination. The Medium Film/Screen speed has to be double of the Slow and half of the Fast (a.e. 200-Slow, 400-Medium, 800-Fast).

Note 

When using CR (Computer Radiography) or DR (Digital Radiography) instead of measuring Optical Density:

- measure the Image Gray level by using the needed software tools inside each application (refer CR or DR documentation).

- or measure the Dose level:

- For CR, placing the Dosimeter as close as possible to the Cassette and centered with the Central Area of the Ion Chamber.

- For DR, placing the Dosimeter as close as possible to the Panel, centered with the Central Area of the Ion Chamber and with the Grid removed.

The following table indicates the Memory Locations related to AEC Calibration.

FUNCTION	MEMORY LOCATION
AEC-1 CALIBRATION	E04
AEC-1 TRACKING	E08
AEC-2 CALIBRATION	E09
AEC-2 TRACKING	E10
AEC-3 CALIBRATION	E20
AEC-4 CALIBRATION / PHOTOMULTIPLIER AEC CALIBRATION	E23
AEC-3 and AEC-4 TRACKING (equal value for both)	E24
AEC DENSITY SCALE	E12



Previous to AEC Calibration, identify and note which Memory Locations are assigned / related to each Ion Chamber / Photomultiplier in the system regarding to the configured Workstation / Devices.

**Illustration 2-1
Automatic Exposure Control**

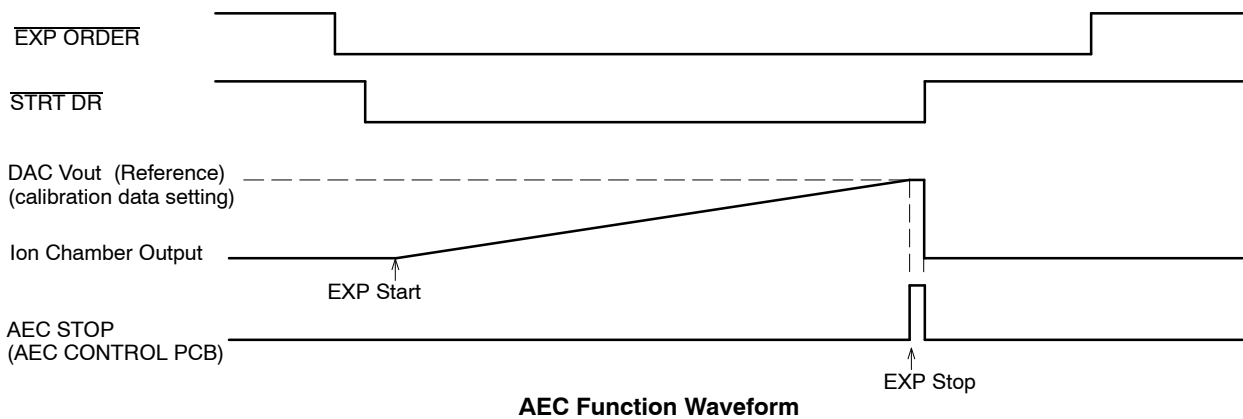
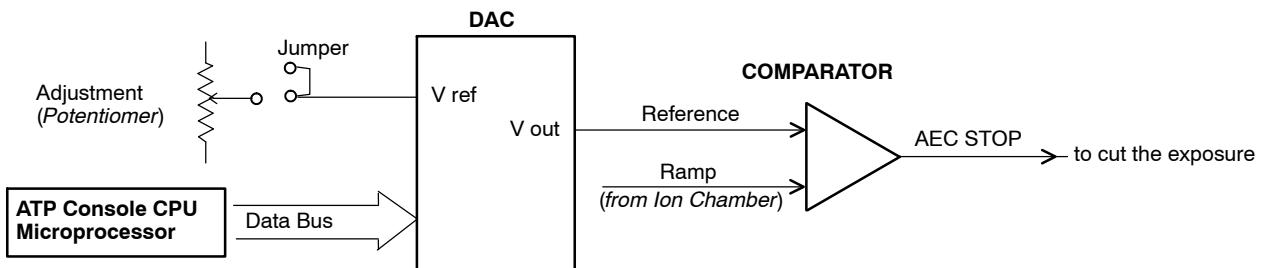

2.6.1 PREVIOUS CHECKS

Make sure the automatic processor works correctly, and the concentration and temperature of the solutions comply with manufacturer specifications.

Obtain a sensitometric curve to determine gamma (γ) of the film and the solution quality. The procedure normally requires a sensitometer, but if it is not available proceed as follows:

1. Make two exposures using the same kV and Film/Screen combination (medium is recommended) but with different mAs settings, mAs(f1) and mAs(f2).
2. Develop and measure the Density (d) of each, d(f1) and d(f2).
3. Determine gamma (γ) by the formula:

$$\gamma = \frac{d(f2) - d(f1)}{\log_{10} \frac{mAs(f2)}{mAs(f1)}}$$

Gamma (γ) must be between 2 and 3, if not change or renew solutions.

2.6.2 BALANCE ADJUSTMENT FOR THREE FIELD DETECTORS

Note 

Some Ion Chambers does not provide balance potentiometers for Three Field Detectors. Continue calibration process in Section 2.6.3 "Optical Density Adjustment".

1. Set the Master Gain potentiometer of the Ion Chambers to mid range (refer to Ion Chamber documentation).
2. Set the following jumper on the AEC Control Board in position A: JP3 for Board A3012-x1/x2/x5 or JP2 for Board A3012-x6/x7/x9.
3. Set SID at the Focal Distance of the Grid installed in the Table Bucky (usually 100 cm) or in the Vertical Bucky Stand (usually 150 cm).
4. Collimate the X-ray beam so that it completely covers all three fields but does not extend beyond limits of the phantom.
5. Place Copper plates (or equivalent homogeneous phantom) in the Collimator Filter Holder: 1.5 mm for SID of 100 cm, 1 mm for SID 150 cm. (1 mm Copper \approx 10 cm Plexiglass or Water).
6. Enter in calibration mode and verify that AEC Calibration number in E04, E09, E20 and E23 Memory Locations is 70. The range for AEC calibration numbers are from 20 to 120. Exit from calibration mode.
7. Enter in calibration mode selecting a Workstation configured for the Ion Chamber to be calibrated. Enter in user mode inside calibration mode by pressing the "Go to User Mode" button.

8. Select on the Console:

- RAD Menu: 70 kV, 200 mA Large Focus (or the first mA station for Large Focus if 200 mA station is set for Small Focus) and 1 second back-up time.
- AEC Menu: “Central Area” , “Density 0” and “Medium Film/Screen”.

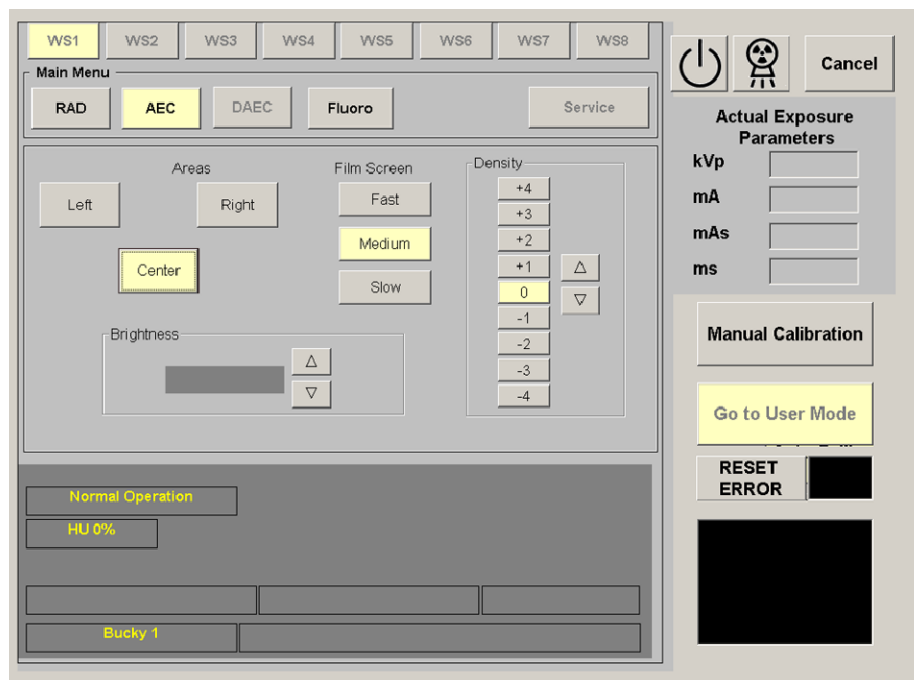
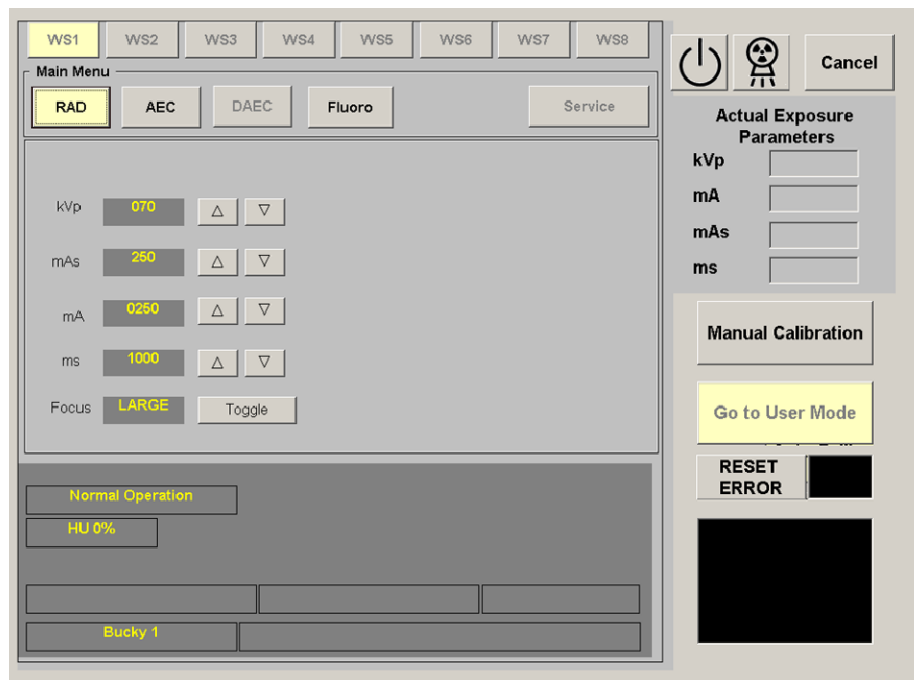

9. Make an exposure without film in the cassette and note the Exposure Time displayed on the Console, it should be approximately 100 ms. If necessary, change the Copper thickness or mA station and make the exposure again.

Note 

The “Actual Exposure Parameters” area shows the last exposure parameters when: exposure is finished by the AEC, exposure is aborted by releasing the exposure control, or after pressing the “Reset Error” button.

10. Deselect “Center Area” and select “Left Area”. Make an exposure without film in the cassette and record the Exposure Time. If this time is not equal to the “Center Area” time ($\pm 7\%$), check that the Ion Chamber is parallel to the X-ray Tube and make an exposure again. If it is parallel, adjust “Left Area” balance potentiometer to increase or decrease Exposure Time. Repeat this process until both Exposure Times for “Center Area” and “Left Area” are equal.
11. Deselect “Left Area” and select “Right Area”. Make an exposure without film in the cassette and record the Exposure Time. If this time is not equal to the “Center Area” time ($\pm 7\%$), adjust “Right Area” balance potentiometer to increase or decrease Exposure Time. Repeat process until both Exposure Times for “Center Area” and “Right Area” are equal.
12. Check that the three scan Areas have equal Exposure Time ($\pm 7\%$):
 - “Center Area” with “Left Area”, “Center Area” with “Right Area”, and “Left Area” with “Right Area”.
 - All three Areas.
13. Exit from the “Go to User Mode” screen by pressing the “Manual Calibration” button and exit from calibration mode.
14. Repeat the above steps for all the Ion Chambers installed with the Generator.

2.6.3 OPTICAL DENSITY ADJUSTMENT

Note 

The Film Optical Density must be measured always on the same point for all the X-ray Films developed during this procedure.

The recommended point is on the central axis of the Film with relation of the Anode and Cathode and as close as possible to center of the Film.

Illustration 2-2
How to measure the Film Optical Density

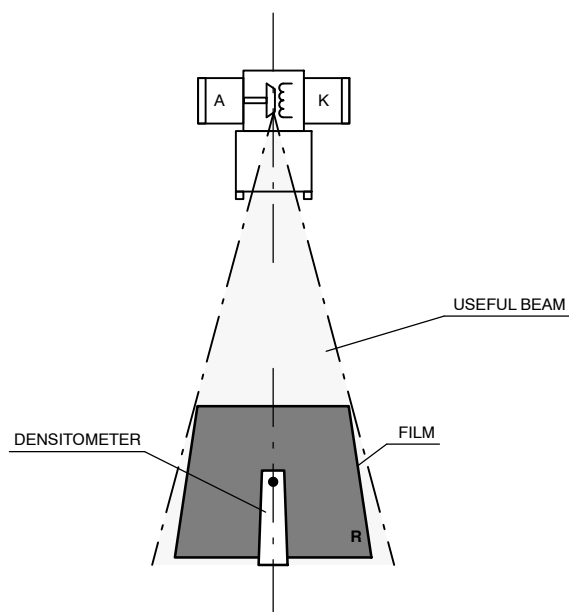

2.6.3.1 ION CHAMBERS WITH DETECTOR GAIN SWITCHES OR WITH POTENTIOMETER

1. Set the Detector Gain switches (or gain potentiometer) of the Ion Chamber to mid range (*refer to Ion Chamber documentation*). (*If the Ion Chamber is provided with the Generator, this adjustment is Factory set.*)

The following tables indicate the switch position for the “Vacutec” Ion Chamber (*Factory set*).

VACUTEC ION CHAMBER - BAK 70 151 with Amplifier 70 901					
SWITCH POSITION		SW1	SW2	SW3	SW4
GAIN	0.1 V / μ Gy (10 V \approx 100 μ Gy)	OFF	OFF	OFF	
	0.5 V / μ Gy (10 V \approx 20 μ Gy)	ON	OFF	OFF	
	1 V / μ Gy (10 V \approx 10 μ Gy)	OFF	ON	OFF	
	2 V / μ Gy (10 V \approx 5 μ Gy)	OFF	OFF	ON	
OUTPUT SIGNAL	Positive				ON
	Negative				OFF
NORMAL FACTORY SELECTION: 1 V / μGy (10 V \approx 10 μGy) - Positive		OFF	ON	OFF	ON

VACUTEC DIGITAL ION CHAMBER - BAK 70 151 with Amplifier 70 902					
SWITCH POSITION		SW1	SW2	SW3	SW4
GAIN	0.1 V / μ Gy (10 V \approx 100 μ Gy)	OFF	OFF	OFF	OFF
	0.5 V / μ Gy (10 V \approx 20 μ Gy)	OFF	OFF	OFF	ON
	1 V / μ Gy (10 V \approx 10 μ Gy)	OFF	OFF	ON	OFF
	2 V / μ Gy (10 V \approx 5 μ Gy)	OFF	ON	OFF	OFF
	4 V / μ Gy (10 V \approx 2.5 μ Gy)	ON	OFF	OFF	OFF
OUTPUT SIGNAL	Positive or Negative polarity of the ramp signal is selected with a switch at the Ramp Module. The Ramp Module is a 9-pin Sub-D connector plugged to the Ion Chamber cable. Positive polarity of the ramp signal is factory set.				
NORMAL FACTORY SELECTION: 1 V / μGy (10 V \approx 10 μGy) - Positive		OFF	OFF	ON	OFF

2. Set the following jumper on the AEC Control Board in position A: JP3 for Board A3012-x1/x2/x5 or JP2 for Board A3012-x6/x7/x9.
3. Set SID at the Focal Distance of the Grid installed in the Table Bucky (usually 100 cm) or in the Vertical Bucky Stand (usually 150 cm).
4. Collimate the X-ray beam so that it completely covers all three fields but does not extend beyond limits of the phantom.
5. Place Copper plates (or equivalent homogeneous phantom) in the Collimator Filter Holder: 1.5 mm for SID of 100 cm, 1 mm for SID 150 cm. (*1 mm Copper ≈ 10 cm Plexiglass or Water*).
6. Enter in calibration mode and verify that AEC Calibration number in E04, E09, E20 and E23 Memory Locations is 70. The useful range for AEC calibration numbers is from 20 to 120. Exit from calibration mode.
7. Enter in calibration mode selecting a Workstation configured for the Ion Chamber to be calibrated. Enter in user mode inside calibration mode by pressing the "Go to User Mode" button.
8. Select on the Console:
 - RAD Menu: 70 kV, 200 mA Large Focus (or the first mA station for Large Focus if 200 mA station is set for Small Focus) and 1 second back-up time.
 - AEC Menu: "Central Area" , "Density 0" and "Medium Film/Screen".
9. Make an exposure without film in the cassette and note the Exposure Time displayed on the Console, it should be approximately 100 ms. If necessary, change the Copper thickness (or if needed change the mA station) and make the exposure again.

Note 

The "Actual Exposure Parameters" area shows the last exposure parameters when: exposure is finished by the AEC, exposure is aborted by releasing the exposure control, or after pressing the "Reset Error" button.

10. Insert a cassette with the Medium Film/Screen combination used by the customer. Make an exposure, develop the film and check the Optical Density, it should be 1.0 (or the customer preference O. Density).
11. To change the density:
 - For Ion Chamber with Gain switches:
 - If the Optical Density obtained is 33% above of the desired density, increase the gain with the switches. Repeat step-10.
 - If the Optical Density obtained is 33% below of the desired density, decrease the gain with the switches. Repeat step-10.
 - If the Optical Density obtained is in between 33% of the desired density, change the AEC calibration number. Exit from the "Go to User Mode" screen by pressing the "Manual Calibration" button and in calibration mode set the new AEC calibration number for the respective Memory Location (E04, E09, E20 or E23). The Optical Density increases / decreases when the calibration number is increased / decreased. Then enter in "User Mode" screen and repeat step-10.
 - For Ion Chamber with Master Gain potentiometer, adjust this potentiometer until the desired density is obtained by repeating step-10. If the adjustment is not achieved with the Master Gain potentiometer, change the AEC calibration number. Exit from the "Go to User Mode" screen by pressing the "Manual Calibration" button and in calibration mode set the new AEC calibration number for the respective Memory Location (E04, E09, E20 or E23). The Optical Density increases / decreases when the calibration number is increased / decreased. Then enter in "Go to User Mode" screen and repeat step-10.

Note 

The AEC accuracy is better in all the useful range as the AEC calibration number is closer to 70.

12. Repeat the above steps for all the Ion Chambers installed with the Generator.
13. Exit from the "Go to User Mode" screen by pressing the "Manual Calibration" button and exit from calibration mode.
14. Record all the values for the Memory Locations in the Data Book.

2.6.3.2 ION CHAMBERS WITHOUT DETECTOR GAIN SWITCHES OR WITHOUT POTENTIOMETER

1. Set the following jumper on the AEC Control Board in position B: JP3 for Board A3012-x1/x2/x5 or JP2 for Board A3012-x6/x7/x9.
2. Set to mid range, the following potentiometer on the AEC Control Board: R10 for Board A3012-x1/x2/x5 or R22 for Board A3012-x6/x7/x9.



The density adjustment of ALL the Ion Chambers in the system are affected by this potentiometer.

3. Set SID at the Focal Distance of the Grid installed in the Table Bucky (usually 100 cm) or in the Vertical Bucky Stand (usually 150 cm).
4. Collimate the X-ray beam so that it completely covers all three fields but does not extend beyond limits of the phantom.
5. Place Copper plates (or equivalent homogeneous phantom) in the Collimator Filter Holder: 1.5 mm for SID of 100 cm, 1 mm for SID 150 cm. (1 mm Copper \approx 10 cm Plexiglass or Water).
6. Enter in calibration mode and verify that AEC Calibration number in the related E04, E09, E20 or E23 Memory Location is 70. The useful range for AEC calibration numbers is from 20 to 120. Then exit from calibration mode.
7. Enter in calibration mode selecting the Workstation configured for the Ion Chamber to be calibrated. Enter in user mode inside calibration mode by pressing the "Go to User Mode" button.
8. Select on the Console:
 - RAD Menu: 70 kV, 200 mA Large Focus (or the first mA station for Large Focus if 200 mA station is set for Small Focus) and 1 second back-up time.
 - AEC Menu: "Central Area" , "Density 0" and "Medium Film/Screen".

9. Make an exposure without film in the cassette and note the Exposure Time displayed on the Console, it should be approximately 100 ms. If necessary for that, change the Copper thickness (or if needed change the mA station) and make the exposure again. Take note of the final Copper thickness and mA station selected.

Note 

The “Actual Exposure Parameters” area shows the last exposure parameters when: exposure is finished by the AEC, exposure is aborted by releasing the exposure control, or after pressing the “Reset Error” button.

10. Exit from the “Go to User Mode” screen by pressing the “Manual Calibration” button and exit from calibration mode.
11. **Repeat the above steps for each Ion Chamber.**
12. Enter in calibration mode selecting a Workstation configured for the Ion Chamber to be calibrated. Enter in user mode inside calibration mode by pressing the “Go to User Mode” button.
13. Insert a cassette with the Medium Film/Screen combination used by the customer. Make an exposure (*use the final Copper thickness and the selected mA station noted before*), develop the film and take note of the Optical Density measured for each Ion Chamber.
14. Exit from the “Go to User Mode” screen by pressing the “Manual Calibration” button and exit from calibration mode.
15. Repeat steps 12. and 13. **for each Ion Chamber.**

16. Take the maximum and minimum value of the O. Densities measured before, sum them and divide the result by two. Subtract this value from density 1.0 (or the customer preference O. Density) to obtain the O. Density difference.

$$O.D. \text{ difference} = O.D. \text{ customer preference} - \frac{O.D. \text{ max} + O.D. \text{ min}}{2}$$

Calculate the new O. Density by adding the O. D. difference (with its sign + or -) to the value of the O. Density measured for the Ion Chamber closer to 1.0 (or the customer preference O. Density).

$$\text{new O.D.} = O.D. \text{ measured} + (O.D. \text{ difference})$$

For this Ion Chamber, adjust the potentiometer (*turning it clockwise will decrease the O. Density*) R10 for Board A3012-x1/x2/x5 or R22 for Board A3012-x6/x7/x9 (*at least one turn*).

Enter in calibration mode selecting a Workstation configured for the Ion Chamber to be calibrated. Enter in user mode inside calibration mode by pressing the “Go to User Mode” button. Make another exposure, develop the film and check the Optical Density. Repeat this action (adjusting the potentiometer and making exposures) until the new Optical Density (calculated before) for this Ion Chamber is obtained.

17. The Optical Density for each Ion Chamber has to be adjusted to 1.0 (or the customer preference O. Density).

Exit from the “Go to User Mode” screen by pressing the “Manual Calibration” button and in calibration mode select the AEC calibration number for the respective Memory Location (E04, E09, E20 or E23). Change the AEC calibration number: the Optical Density increases / decreases when the calibration number is increased / decreased. Then enter in “Go to User Mode” screen.

Make another exposure, develop the film and check the Optical Density. Repeat this action (changing the respective Memory Location and making exposures) until the desired Optical Density is obtained.

Note 

The AEC accuracy is better in all the useful range as the AEC calibration number is closer to 70.

18. Repeat step-17. until the desired Optical Density for each Ion Chamber is obtained.
19. Exit from the “Go to User Mode” screen by pressing the “Manual Calibration” button and exit from calibration mode.
20. Record all the values for the Memory Locations in the Data Book.

2.6.4 kV COMPENSATION

To maintain constant AEC Optical Density regardless of the kV at which a film is exposed, the Generator provides kV compensation. (*Refer to Illustration 2-3*)

Perform the following steps to determine whether or not AEC Tracking of Optical Density must be adjusted.

1. Enter in calibration mode and verify that AEC Tracking number in E08, E10 and E24 Memory Locations is "0". Exit from calibration mode.
2. Enter in calibration mode selecting a Workstation configured for the Ion Chamber to be calibrated. Enter in user mode inside calibration mode by pressing the "Go to User Mode" button.
3. Select on the Console:
 - RAD Menu: 55 kV, 200 mA Large Focus (or the first mA station for Large Focus if 200 mA station is set for Small Focus) and 1 second back-up time.
 - AEC Menu: "Central Area" , "Density 0" and "Medium Film/Screen".
4. Make an exposure without film in the cassette and check that the Exposure Time is lower than 1 second. If necessary for that, change the Copper thickness (or if needed change the mA station) and make the exposure again. Take note of the final Copper thickness and mA station selected for 55 kV.
5. Select 90 kV. Make an exposure without film in the cassette and check that the Exposure Time is higher than 20 ms. If necessary for that, change the Copper thickness (or if needed change the mA station) and make the exposure again. Take note of the final Copper thickness and mA station selected for 90 kV.
6. Select 110 kV. Make an exposure without film in the cassette and check that the Exposure Time is higher than 20 ms. If necessary for that, change the Copper thickness (or if needed change the mA station) and make the exposure again. Take note of the final Copper thickness and mA station selected for 110 kV.
7. Insert a cassette with the Medium Film/Screen combination used by the customer. Make an exposure at 55 kV and 90 kV (*use the final Copper thickness and the selected mA station noted before for each kV*), develop the film and measure the Optical Density obtained with those exposures. Check that the film variation range is the same ± 0.2 of the Optical Density ($\pm 20\%$ of Image Gray Level / Dose Level with CR or DR) obtained before at 70 kV (*Optical Density Adjustment - Section 2.6.3*).

8. If the variation value is not ± 0.2 of the Optical Density ($\pm 20\%$ of Image Gray Level / Dose Level with CR or DR) calculate the new value for the AEC Tracking number in each Memory Location in the following manner:
 - If the Optical Density at 55 kV has to be decreased and the Optical Density above 70 kV has to be increased then **increase the Tracking value in one.**
 - If the Optical Density at 55 kV has to be increased and the Optical Density above 70 kV has to be decreased then **decrease the Tracking value in one.**

Note 

A tracking value of 10 will have no effect on AEC density (used in solid state detectors).

- a. Exit from the “Go to User Mode” screen by pressing the “Manual Calibration” button and in calibration mode select the respective Memory Location (E08, E10 or E24).
- b. Values for AEC Tracking range is from -10 to +10. Determine the correct value for the needed AEC Tracking change.

AEC-kV TRACKING CURVE	+10	+9	+8	+7	+6	+5	+4	+3	+2	+1	0	-1	-2	-3	-4	-5	-6	-7	-8	-9	-10
VALUE TO ENTER IN THE MEMORY LOCATION	10	9	8	7	6	5	4	3	2	1	0	255	254	253	252	251	250	249	248	247	246

- c. Enter the new value and store it. Enter in user mode inside calibration mode by pressing the “Go to User Mode” button and repeat this process from step-7. until the desired density compensation is obtained.
9. Insert a cassette with the Medium Film/Screen combination used by the customer. Make an exposure at 110 kV (*use the final Copper thickness and the selected mA station noted before for 110 kV*), develop the film and measure the Optical Density obtained with those exposures. Check that the film variation range is the same ± 0.2 of the Optical Density ($\pm 20\%$ of Image Gray Level / Dose Level with CR or DR) obtained before at 70 kV (*Optical Density Adjustment – Section 2.6.3*). If the variation value is not ± 0.2 repeat step-8.

Note 

Calibration of AEC Tracking at 110 kV modifies the adjustment done at 55 kV and 90 kV. Repeat exposures of step-7. and check that they are correct.

In case that the AEC Tracking at 110 kV places the adjustment at 55 kV and 90 kV out of range, choose the AEC Tracking value more convenient for the application.

10. Repeat the above steps for all the Ion Chambers installed with the Generator.
11. Exit from the "Go to User Mode" screen by pressing the "Manual Calibration" button and exit from calibration mode.
12. Record all the values for the Memory Locations in the Data Book.

Illustration 2-3
AEC kV Tracking Curve

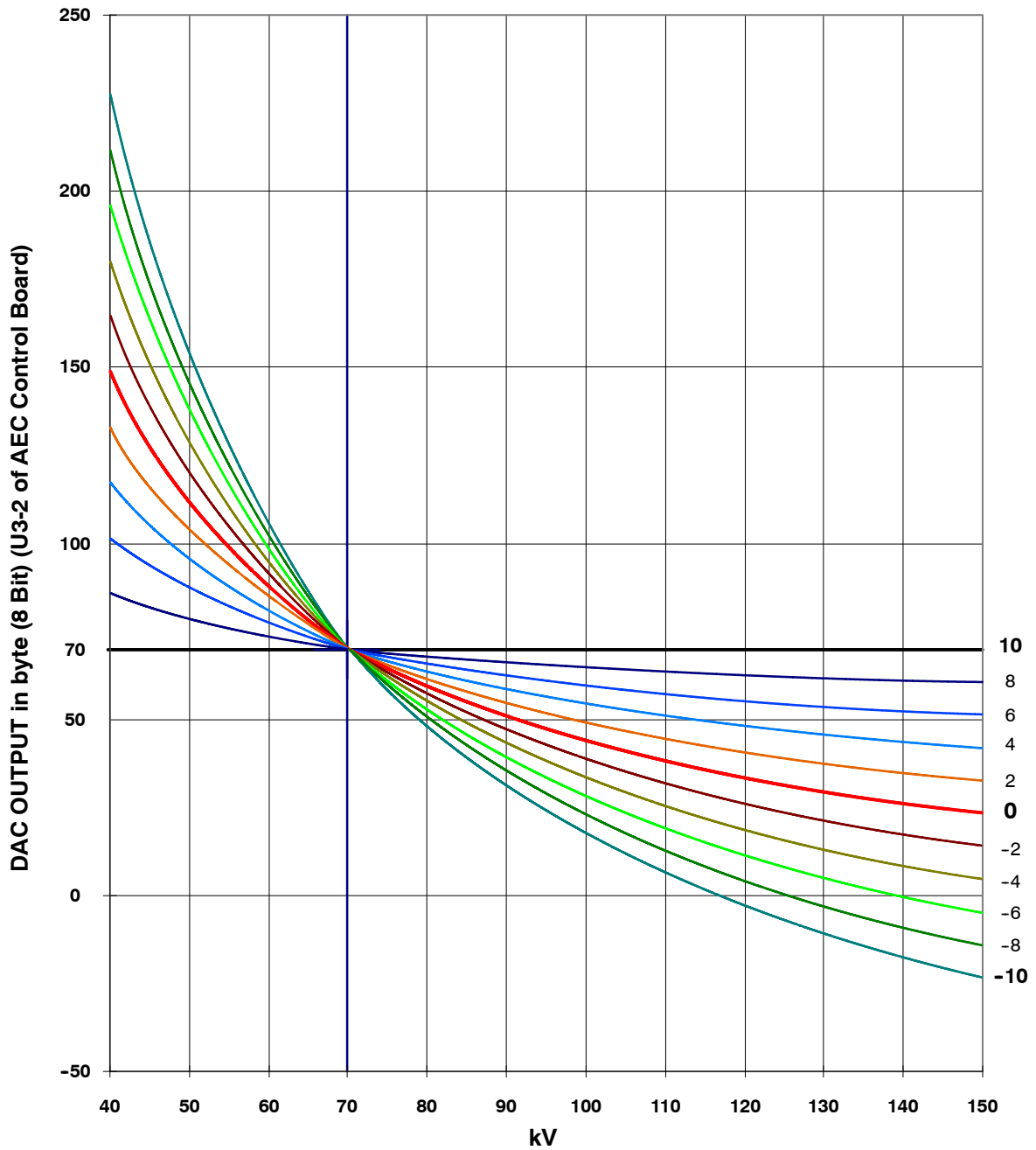

2.6.5 ATS DIGITAL AEC (RAD) ADJUSTMENT (OPTIONAL)

Note 

If the Generator is interfaced with an “ATS Hiris Image System”, Digital AEC calibration procedure has to be performed as explained in the “ATS Hiris Image System” documentation.

2.6.6 PHOTOMULTIPLIER RAD-AEC (DIGITAL RAD) ADJUSTMENT (OPTIONAL)

The Photomultiplier RAD-AEC adjustment can be performed in two ways: one is the value stored in E23 Memory Location and the other is the high voltage applied to the Photomultiplier Tube.

The recommended procedure for this adjustment is to store a constant value in E23 Memory Location and adjust the high voltage applied to the Photomultiplier Tube.

Note 

Value in E23 Memory Location is a common data used for Photomultiplier AEC Calibration or used for the Fourth Ion Chamber Calibration (AEC-4).

Perform the following procedure:

1. Enter in “Manual Calibration” mode selecting a Workstation configured for DSI. Select E23 Memory Location and set a value of “127”. Then enter in user mode by pressing the “Go to User Mode” button.
2. Set up a Dosimeter as close as possible to the Image Intensifier Radiation Input to measure the Entrance Image Intensifier Exposure Dose Rate. Position the Probe at the center of the primary beam with the entire active volume within the primary beam. Select the Field of View for the Image Intensifier to have 9” FOV.

Place the Tube-Collimator Assembly at the normal SID (1 meter). Collimate the X-ray beam so it completely covers the Image Intensifier field but does not extend beyond limits of the phantom.

3. Place 2 mm of Copper (or equivalent homogeneous phantom) in the Collimator Filter Holder. (*1 mm Copper \approx 10 cm Plexiglass or Water*).

4. Select on the Console:
 - RAD Menu: 70 kV, 200 mA Large Focus (or the first mA station for Large Focus if 200 mA station is set for Small Focus) and 1 second back-up time.
 - AEC Menu: “Central Area” , “Density 0” and “Medium Film/Screen”.
5. Activate “Digital Prep” (-DIGITAL PREP signal = GND on TS3-7 Generator Cabinet). Hold “Digital Prep” and adjust the high voltage applied to the Photomultiplier Tube with the potentiometer R12 for Board A3012-x1/x2/x5 or R23 for Board A3012-x6/x7/x9 on the AEC Control Board until measure -400 VDC between TS1-39 and TS1-42 (GND) in the Generator Cabinet.
6. The Dose is affected in the following manner:
 - Increases when the high voltage applied to the Photomultiplier Tube is decreased. (*Example: if 100 μ R Dose is obtained with -400 VDC, 200 μ R Dose may be obtained decreasing the high voltage to -300 VDC*).
 - Decreases when the high voltage applied to the Photomultiplier Tube is increased. (*Example: if 100 μ R Dose is obtained with -400 VDC, 50 μ R Dose may be obtained increasing the high voltage to -450 VDC*).
7. Make an exposure and adjust the following potentiometer on the AEC Control Board: R12 for Board A3012-x1/x2/x5 or R23 for Board A3012-x6/x7/x9 on the AEC Control Board; until getting a Dose around 100 μ R per frame (at 9” FOV) (*for more information refer to the Image System documentation*).

Note 

If the photo tube voltage required is too low, decrease the AEC calibration number in the E23 Memory Location and repeat the process.

8. Record the E23 Memory Location in the Data Book.

2.6.7 AEC OPTICAL DENSITY SCALE

AEC is calibrated with “Density 0” selected (Normal Optical Density). The Optical Density can be increased or decreased in several steps.

The variation percentage of the density scale is factory set at 25%. This variation can be set according to the customer preferences by changing the value stored in E12 Memory Location. This value applies to both tubes.

Depending on the Console model, the range of the scale is “from -2 to +2” or “from -4 to +4” (optional).

The following tables show some examples for the variation percentage of the density scale with reference to the value stored in E12 Memory Location.

E12 VALUE	DENSITY SCALE FROM -2 TO +2 . VARIATION OVER NORMAL OPTICAL DENSITY (N)				
	-2	-1	0	+1	+2
5	N x 0.90	N x 0.95	N	N x 1.05	N x 1.10
10	N x 0.80	N x 0.90	N	N x 1.10	N x 1.20
25	N x 0.50	N x 0.75	N	N x 1.25	N x 1.50

NOTE: If the value stored in E12 Memory Location is 0, 25 or 255, the variation percentage is 25%.

E12 VALUE	DENSITY SCALE FROM -4 TO +4 (OPTIONAL) . VARIATION OVER NORMAL OPTICAL DENSITY (N)									
	-4	-3	-2	-1	0	+1	+2	+3	+4	
5	N x 0.82	N x 0.86	N x 0.91	N x 0.95	N	N x 1.05	N x 1.10	N x 1.16	N x 1.22	
10	N x 0.68	N x 0.75	N x 0.83	N x 0.91	N	N x 1.10	N x 1.21	N x 1.33	N x 1.46	
25	N x 0.41	N x 0.51	N x 0.64	N x 0.80	N	N x 1.25	N x 1.56	N x 1.95	N x 2.44	

NOTE: With scale from “-4 to +4” the useful range for the value stored in E12 Memory Location is from 1 to 25 .

Record the value for E12 Memory Location in the Data Book.

2.7 FLUORO CALIBRATION

This generator uses Pulsed Fluoro at fixed or variable rate. This technique is a series of short exposures at the TV frame rate (fixed rate) or at the selected PPS (variable rate).

Fluoro exposures are controlled by kV with a constant filament current. The kV values are manually (Manual mode) or automatically (ABC mode) adjusted to obtain the desired brightness (entrance dose rate) on the Image Intensifier.

The Fluoro calibration consists of setting values in the corresponding Extended Memory Locations for Fluoro use. The following table indicates the relationship between Fluoro and Extended Memory Locations.

FUNCTION	MEMORY LOCATIONS
Fluoro Filament Setting	E17
Maximum Fluoro kV	E19
Fluoro mA Display Calibration at 50 kV	E25
Fluoro mA Display Calibration at 80 kV	E26
Fluoro mA Display Calibration at 120 kV	E27

The functions of these extended Memory Locations are:

- E17 is used to store data that controls the Maximum Skin Dose Radiation at the following maximum levels (Regulation limits) (1 Rad = 8.7 mGy).
 - 5 R/min (43.5 mGy/min) for systems working with Manual mode (Non-ABC).
 - 10 R/min (87 mGy/min) for systems working with Automatic mode (ABC).

Note that in practice, the rejection limits for entrance exposure rate must be somewhat less than the maximum specified due to Dosimeter calibration accuracy. (Refer to Table 2-2.)

**Table 2-2
Rejection Limits Based on Meter Calibration Accuracy**

METER CALIBRATION ACCURACY	REJECTIONS LIMITS	
	FOR 5 R/min (43.5 mGy/min) MAXIMUM	FOR 10 R/min (87 mGy/min) MAXIMUM
±5%	4.75 R/min (41.3 mGy/min)	9.5 R/min (82.7 mGy/min)
±10%	4.50 R/min (39.2 mGy/min)	9.0 R/min (78.3 mGy/min)
±15%	4.25 R/min (37 mGy/min)	8.5 R/min (74 mGy/min)

- E19 is used to set maximum Fluoro kV. This value is determined by the type of TV camera and type of images desired. For general fluoroscopic use with a conventional TV system, 120 kV is recommended. A lower maximum setting will produce more contrast on the TV system but less penetration for large patients.
- E25, E26, E27 are used to calibrate the Fluoro mA Display. These values will be shown on the Fluoro mA Display during Fluoro exposures whenever maximum PPS are selected.

Note 

The Fluoro mA Display values entered into the Extended Memory Locations E25, E26 and E27 are also used to calculate Heat Units. It is important to enter accurate values.

Fluoro functions are calibrated by performing the following steps:

1. Turn the generator ON.



Make sure that the Small Filament of the X-ray tube is properly warmed-up (at less 15 minutes).

2. Set up a Dosimeter to measure the Maximum Entrance Skin Exposure Dose Rate. Position the Probe at the center of the primary beam with the entire active volume within the primary beam.

Place the Tube-Collimator Assembly as close as possible to the Table-Top, fully open the Collimator Blades and align the Image Intensifier with the light beam. Block radiation input to Image Intensifier with a Lead Apron. (Refer to Illustration 2-4).

3. Enter in "Manual Calibration" mode through a Fluoro workstation and read the Filament Number at 120 kV / 10 mA. Divide this value by four (4) and enter it as starting value for E17 Memory Location (Fluoro Filament Setting).
4. Select E19 Memory Location and set the maximum Fluoro kV at 120 kV or more if it is possible.
5. Enter in user mode inside calibration mode by pressing the "Go to User Mode" button and select the Fluoro Menu.

Illustration 2-4
Fluoro Entrance Exposure Rate Test Set-up

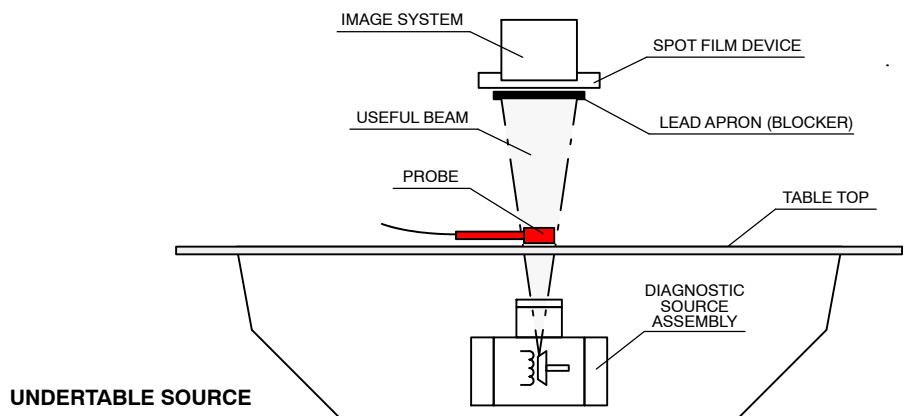
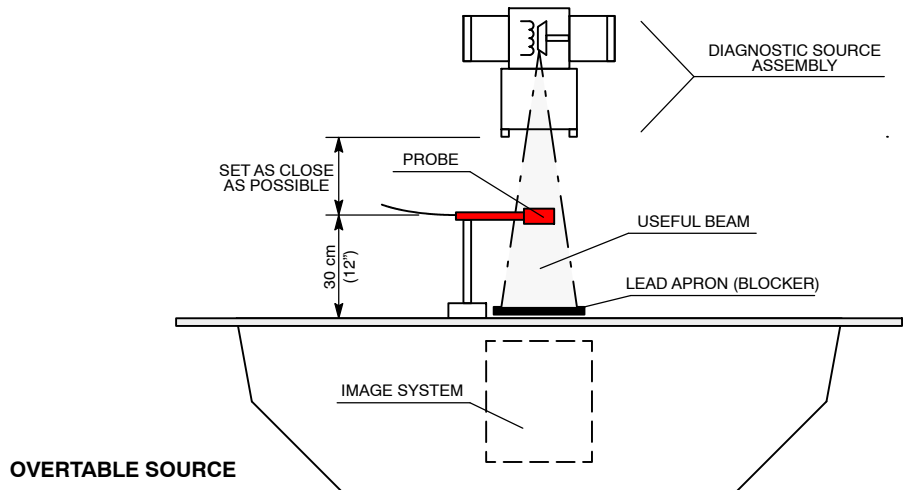

6. Select the maximum PPS and Non-ABC mode. Make a Fluoro exposure at maximum kV that will be used in the system and measure the dose applied, it should not be over the Rejection Limits for 10 R/min (87 mGy/min) or 5 R/min (43.5 mGy/min) (*refer to Table 2-2.*).

In case that the value is not acquired, change the Fluoro Filament Setting stored in E17 as required until it is correctly calibrated to that dose. Keep in mind that radiation increases or decreases in accordance to value in E17 is increased or decreased.

7. The mA values displayed during Fluoro exposures are stored in E25, E26 and E27 Memory Locations. The method used to obtain the Fluoro mA values is to measure the average mA using a mA meter in Fluoro.

During Fluoro exposure, mA values are read directly with a mA Meter in DC connected to the mA Test Points (banana plug connections) on the HV Transformer. Only for this purpose, remove the link between the banana plug connections on the HV Transformer.

Select the maximum PPS and Non-ABC mode. Make the following Fluoro exposures:

- Make a Fluoro exposure at 50 kV and take note below the mA reading, this value will be used as Fluoro mA at minimum kV (E25).
- Make a Fluoro exposure at 80 kV and take note below the mA reading, this value will be used as Fluoro mA at medium kV (E26).
- Make a Fluoro exposure at 120 kV and take note below the mA reading, this value will be used as Fluoro mA at maximum kV (E27).

FL mA value at 50 kV (E25)	FL mA value at 80 kV (E26)	FL mA value at 120 kV (E27)

8. Remove the Dosimeter and the Lead Apron (Blocker).
9. Exit from the “User Mode” screen by pressing “Manual Calibration” button.
10. Select E19 Memory Location if it is required to reduce the value for the maximum Fluoro kV in the installation.
11. Select the E25, E26 and E27 Memory Locations and store the respective mA values noted before multiplied by **10** (a.e. if the mA value noted is “3.2”, store the value “32” in the respective Memory Location).
12. Record the new values in the Data Book.
13. Exit calibration mode.

2.8 ABC CALIBRATION

The purpose of the ABC System is to maintain an optimum constant Image Tube Output Brightness by controlling the X-ray kV during Fluoro exams, regardless of changes in the patient opacity viewed on the TV monitor.

The closed-loop ABC System can monitor the Image Tube Output Brightness through two ways: Photomultiplier Tube or TV Camera.

2.8.1 ABC SYSTEM WITH PHOTOMULTIPLIER TUBE

Note 

This operation requires the AEC Control Board A3012-x6/x7/x9 (Digital version).

On this system the Photomultiplier current signal, which is proportional to the Image Tube Output Brightness, is used as brightness signal “*PT Input*” for the ABC circuitry of the Generator. (*Refer to Illustration 2-5*).

This analogic signal is converted to a voltage signal in the Photomultiplier Amplifier Board and sent to a peak-detector in the AEC Control Board. The peak signal obtained is then held through a “*Sample and Hold*” circuitry after a synchronism pulse. The peak signal held is adapted to obtain finally the “*ABC IN*” signal which is so the Photomultiplier signal-peak held between synchronism pulses. This signal is then compared to a window reference.

Brightness error at the comparator output is sent as “*kV Up*” and “*kV Down*” to the Generator where is used to drive the Fluoro kV control. The closed-loop operation requires more or less brightness thru “*kV Up*” and “*kV Down*” demand signals respectively. Patient Entrance Dose is automatically varied so that optimum constant Image Tube Output Brightness is maintained.

The optimum brightness level in ABC mode is set by adjusting Brightness Control Resistor R13 on the AEC Control Board, which controls the output of the Photomultiplier Tube High Voltage power supply on the Interface Control Board (“PT CRL” plus 5 volts programs the output to be 0 volts, and 0 volts programs the output to approximately -1200 volts). The window comparator requires an input range from 0 to +10 VDC for the “ABC IN” (the optimum brightness level will be achieved with a value between 5 and 7 VDC).

Illustration 2-5
ABC System for Photomultiplier Tube

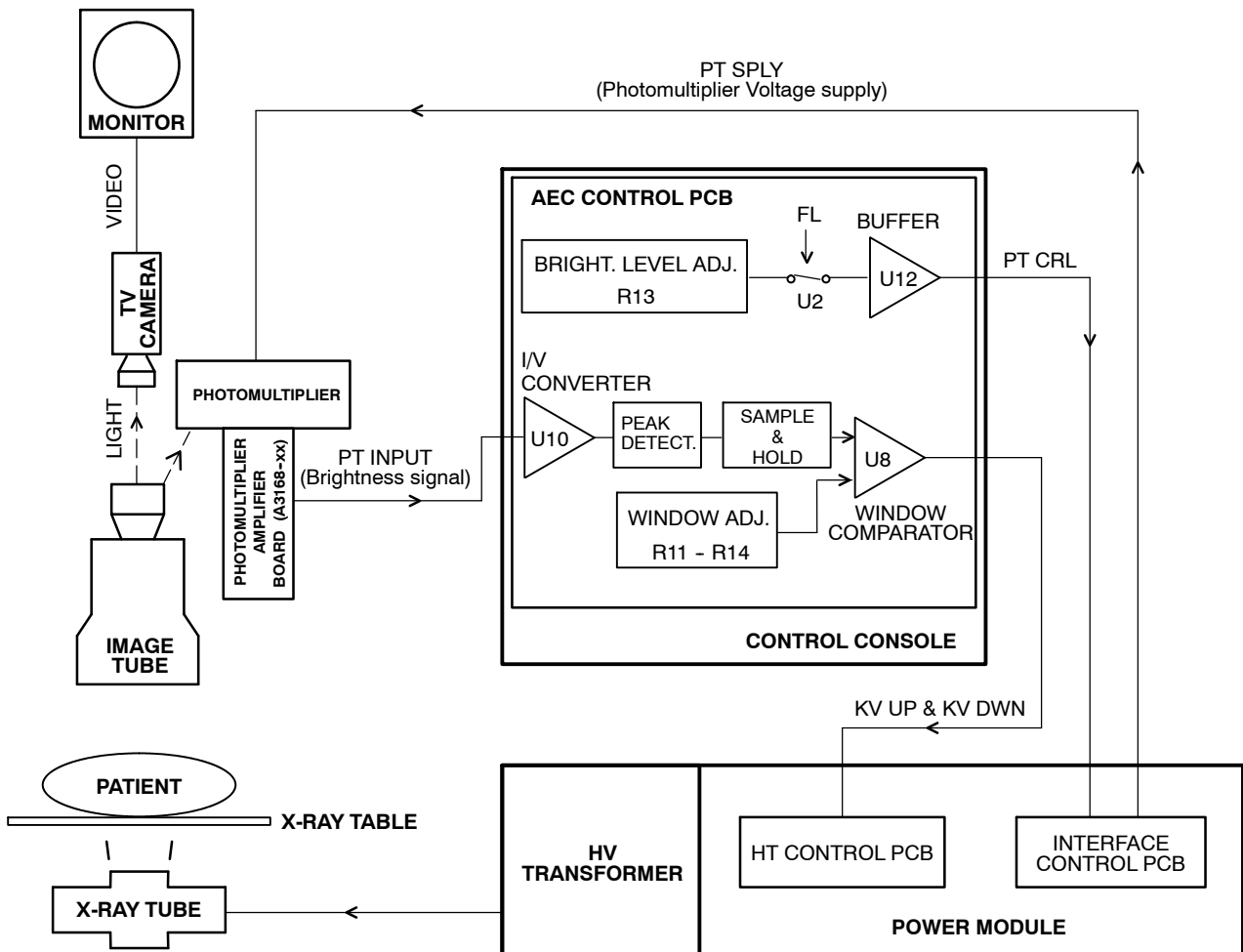

Window reference could be adjusted first to set mid-way the brightness level (+5 VDC), and second to increase or decrease the range of response and sensitivity of the kV control to input variations (brightness changes). If oscillation occurs during ABC fluoro exposure, increase the dead zone by adjusting Resistors R11 and R14 on the AEC Control Board. (Refer to Illustration 2-6 for ABC waveforms).

**Illustration 2-6
ABC Waveforms in AEC Control Board**

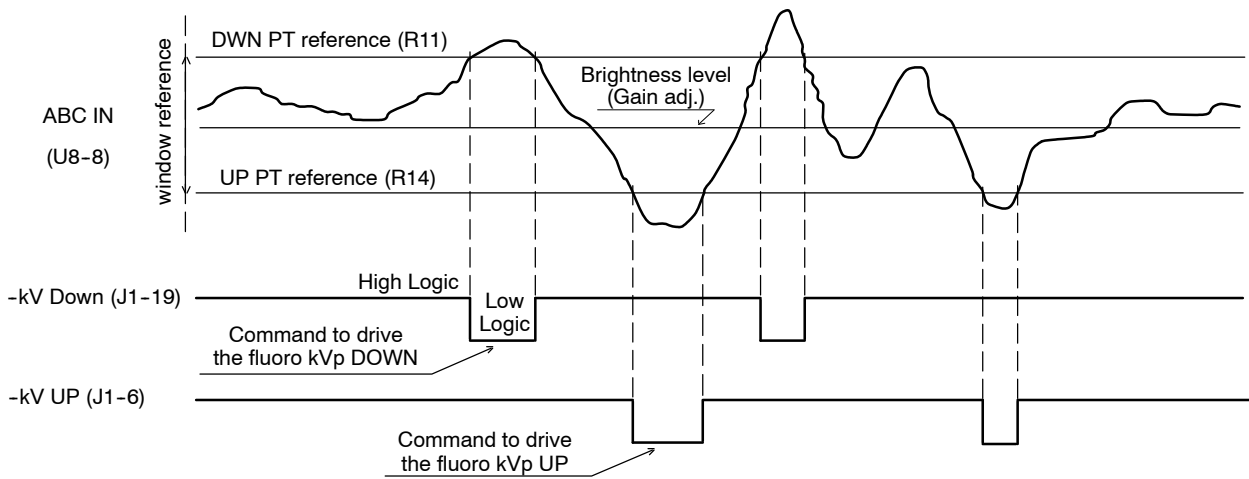

Adjust the ABC system for Photomultiplier Tube as follow:

1. Be sure that the Video System and the Image Intensifier are powered and operating correctly.
2. Set up a Dosimeter as close as possible to the Image Intensifier Radiation Input to measure the Entrance Image Intensifier Exposure Dose Rate. Position the Probe at the center of the primary beam with the entire active volume within the primary beam.

Place the Tube-Collimator Assembly at the normal SID (1 meter), fully open the Collimator Blades and align the Image Intensifier with the light beam.

3. Adjust TV Camera gain for 1 volt peak-to-peak composite video output.
4. Select the maximum PPS and Non-ABC mode.
5. Place 2 mm of Copper (or equivalent homogeneous phantom) in the Collimator Filter Holder.
6. Calculate the value of the optimum radiation (that will give optimum brightness) usually is $2\mu\text{R/frame}$ at 9° FOV (*for more information refer to Image System documentation*).

Examples:

For 25 frame/second optimum radiation is 3 mR/min.

$2\mu\text{R/frame} \times 25\text{ frame/s} = 50\mu\text{R/s}$.

$50\mu\text{R/s} \times 60\text{ s/min} = 3000\mu\text{R/min} = 3\text{ mR/min}$.

For 30 frame/second optimum radiation is 3.6 mR/min.

$2\mu\text{R/frame} \times 30\text{ frame/s} = 60\mu\text{R/s}$.

$60\mu\text{R/s} \times 60\text{ s/min} = 3600\mu\text{R/min} = 3.6\text{ mR/min}$.

The optimum radiation value should be measured at Image Intensifier Radiation Input. Intensifier grid should be removed, if it can not be removed, this value should be multiplied by two or by the value specified as Grid Absorption Factor.

7. Make a Fluoro exposure at 70 kV and measure the radiation. Optimum radiation is obtained by modifying the Fluoro kV or the Copper thickness in the Collimator Filter Holder. First modify the Fluoro kV, if it is more than 80 kV or less than 60 kV modify the Copper thickness in 0.1 mm (or 0.2 mm). Note the value of Fluoro KV and Copper thickness used to obtain the optimum radiation.

Note 

Radiation increases when kV is increased or Copper thickness is reduced.

8. Perform the following adjustments in the AEC Control Board:
 - a. Adjust R13 in order to obtain 6 VDC on TP3 (ABC IN).
 - b. Select 70 kV (or the kV obtained in step-7.) and increase 2 kV and check the increased value of voltage in TP3 (ABC-IN) (if this value has not been increased, increase 1 kV more). Note this value **(consider it as KV-DOWN-SEL)**.
 - c. Select 70 kV (or the kV obtained in step-7.) and decrease 2 kV and check the decreased value of voltage in TP3 (ABC-IN) (if this value has not been decreased, decrease 1 kV more). Note this value **(consider it as KV-UP-SEL)**.
 - d. Obtain in TP1 the same voltage noted as kV-DOWN-SEL (DOWN PT) by adjusting the Potentiometer R11.
 - e. Obtain in TP2 the same voltage noted as kV-UP-SEL (UP PT) by adjusting the Potentiometer R14.
9. Select 70 kV (or the kV obtained in step-7.) and ABC mode.
10. Make a Fluoro exposure and check that the kV does not change.
11. Stop the Fluoro exposure and select 40 kV. Make a Fluoro exposure and check that the kV value goes to 70 kV (or the kV obtained in step-7.) ± 2 kV without System problems.
12. Stop the Fluoro exposure and select 100 kV. Make a Fluoro exposure and check that the kV value goes to 70 kV (or the kV obtained in step-7.) ± 2 kV without System problems.

2.8.2 ABC SYSTEM WITH TV CAMERA

The ABC can be performed with an Analogic Signal Output (*ABC OUT*) proportional to the brightness or with the Composite Video Signal Output from the TV Camera.

The “*ABC OUT*” signal from the TV Camera is compatible with the Generator when the range is from 0 VDC (dark image) to 10 VDC (bright image) and the Optimum Brightness is achieved at around 6 VDC.

When a TV Camera without a direct “*ABC OUT*” signal is used, the Composite Video signal (which amplitude is proportional to the image tube output brightness) is sent to an RF Adaptation Board where it is transformed into an “*ABC OUT*” analogic signal. In this case, the brightness level is taken from a rectangular window from the center of the raster. (Refer to *Illustration 2-7*).

This analogic signal in the AEC Control Board (“*PT Input*” in Board A3012-x1/x2/x5 and “*ABC OUT*” in Board A3012-x6/x7/x9) is filtered, and compared to a window reference. Brightness error at the comparator output is sent as “*kV Up*” and “*kV Down*” to the Generator where is used to drive the fluoro kV control. The closed-loop operation requires more or less brightness thru “*kV Up*” and “*kV Down*” demand signals respectively. Patient entrance dose is automatically varied so that constant image tube output brightness is maintained.

Illustration 2-7
ABC System for TV Camera

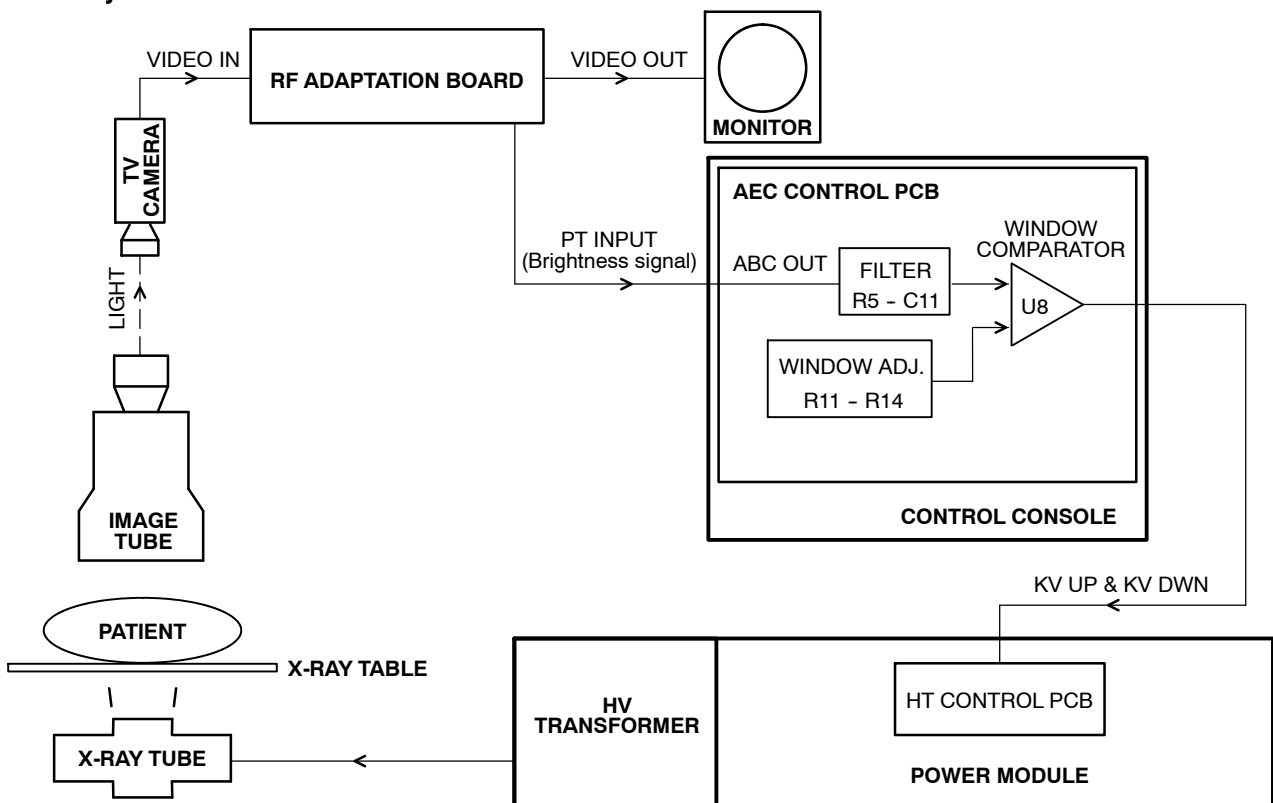

The optimum brightness level in ABC mode is set by adjusting the gain at R27 on the RF Adaptation Board. The “ABC OUT” signal requires an input range from 0 to +10 VDC (the stabilized value will be between 5 and 7 VDC).

Window reference could be adjusted first to set mid-way the brightness level (+6 VDC), and second to increase or decrease the range of response and sensitivity of the kV control to input variations (brightness changes). If oscillation occurs during ABC fluoro exposure, increase the dead zone by adjusting R11 and R14 on the AEC Control Board. (Refer to Illustration 2-8 for ABC waveforms)

For system interface, refer to RF Adaptation Board. Adjust ABC System according to the following procedures.

Illustration 2-8
ABC Waveforms in AEC Control Board

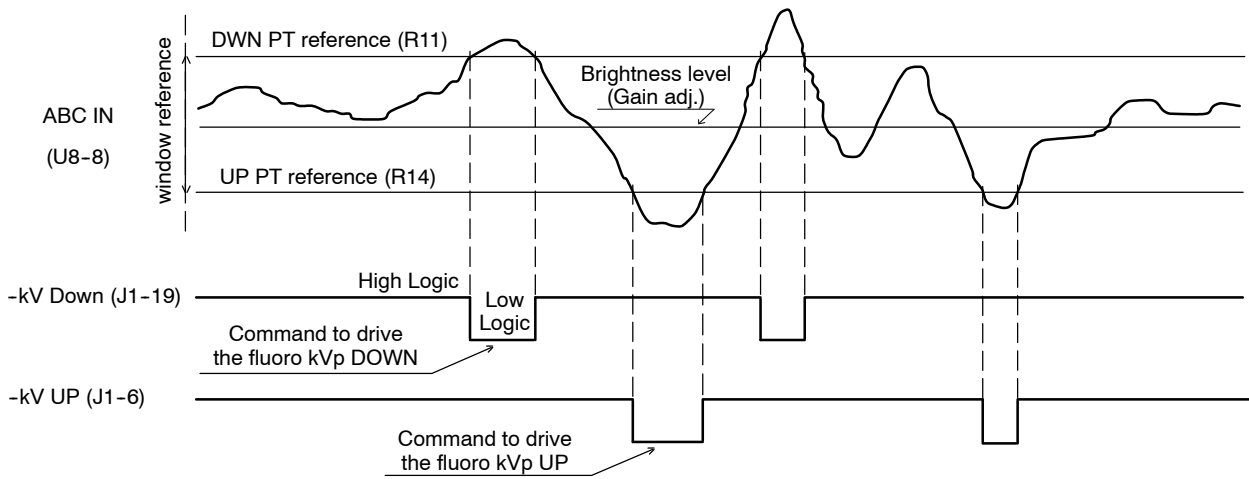

2.8.2.1 ABC SYSTEM ADJUSTMENT WITH ABC SIGNAL FROM TV CAMERA COMPATIBLE WITH THE GENERATOR

1. Be sure that the Video System and the Image Intensifier are powered and operating correctly.
2. Set up a Dosimeter as close as possible to the Image Intensifier Radiation Input to measure the Entrance Image Intensifier Exposure Dose Rate. Position the Probe at the center of the primary beam with the entire active volume within the primary beam.

Place the Tube-Collimator Assembly at the normal SID (1 meter), fully open the Collimator Blades and align the Image Intensifier with the light beam.

3. Adjust TV Camera gain for 1 volt peak-to-peak composite video output.
4. Set Jumper JP21 to position B on the RF Adaptation Board.
5. Select the maximum PPS and Non-ABC mode.
6. Place 2 mm of Copper (or equivalent homogeneous phantom) in the Collimator Filter Holder.
7. Calculate the value of the optimum radiation (that will give optimum brightness) usually is 2 μ R/frame at 9" FOV (*for more information refer to Image System documentation*).

Examples:

For 25 frame/second optimum radiation is 3 mR/min.

2 μ R/frame \times 25 frame/s = 50 μ R/s.

50 μ R/s \times 60 s/min = 3000 μ R/min = 3 mR/min.

For 30 frame/second optimum radiation is 3.6 mR/min.

2 μ R/frame \times 30 frame/s = 60 μ R/s.

60 μ R/s \times 60 s/min = 3600 μ R/min = 3.6 mR/min.

The optimum radiation value should be measured at Image Intensifier Radiation Input. Intensifier grid should be removed, if it can not be removed, this value should be multiplied by two or by the value specified as Grid Absorption Factor.

8. Make a Fluoro exposure at 70 kV and measure the radiation. Optimum radiation is obtained by modifying the Fluoro kV or the Copper thickness in the Collimator Filter Holder. First modify the Fluoro kV, if it is more than 80 kV or less than 60 kV modify the Copper thickness in 0.1 mm (or 0.2 mm). Note the value of Fluoro KV and Copper thickness used to obtain the optimum radiation.

Note 

Radiation increases when kV is increased or Copper thickness is reduced.

9. Perform the adjustment for the window test as specified on the TV Camera manuals. This window defines the area of the image where the brightness will be captured for the ABC and it should be the 25% of the image area.
10. Adjust the TV Camera to obtain +6 VDC (or the voltage supplied by the TV Camera as optimum brightness) on TP3 (ABC IN) on the AEC Control Board (Refer the TV Camera manuals).
11. Perform the following adjustments in the AEC Control Board:
 - a. Select 70 kV (or the kV obtained in step-8.) and increase 2 kV and check the increased value of voltage in TP3 (ABC-IN) (if this value has not been increased, increase 1 kV more). Note this value (**consider it as KV-DOWN-SEL**).
 - b. Select 70 kV (or the kV obtained in step-8.) and decrease 2 kV and check the decreased value of voltage in TP3 (ABC-IN) (if this value has not been decreased, decrease 1 kV more). Note this value (**consider it as KV-UP-SEL**).
 - c. Obtain in TP1 the same voltage noted as kV-DOWN-SEL (DOWN PT) by adjusting the Potentiometer R11.
 - d. Obtain in TP2 the same voltage noted as kV-UP-SEL (UP PT) by adjusting the Potentiometer R14.
12. Select the 70 kV (or the kV obtained in step-8.) and ABC mode.
13. Make a Fluoro exposure and check that the kV does not change.
14. Stop the Fluoro exposure and select 40 kV. Make a Fluoro exposure and check that the kV value goes to 70 kV (or the kV obtained in step-8.) ± 2 kV without System problems.
15. Stop the Fluoro exposure and select 100 kV. Make a Fluoro exposure and check that the kV value goes to 70 kV (or the kV obtained in step-8.) ± 2 kV without System problems.

2.8.2.2 ABC SYSTEM ADJUSTMENT WITH AN ABC SIGNAL FROM TV CAMERA NOT COMPATIBLE WITH THE GENERATOR

1. Be sure that the Video System and the Image Intensifier are powered and operating correctly.
2. Set up a Dosimeter as close as possible to the Image Intensifier Radiation Input to measure the Entrance Image Intensifier Exposure Dose Rate. Position the Probe at the center of the primary beam with the entire active volume within the primary beam.

Place the Tube-Collimator Assembly at the normal SID (1 meter), fully open the Collimator Blades and align the Image Intensifier with the light beam.

3. Adjust TV Camera gain for 1 volt peak-to-peak composite video output.
4. Set on the RF Adaptation Board, Jumpers JP21 to position "A" and JP20 to position "B" (for negative ABC signal) or to position "C" (for positive ABC signal).
5. Select the maximum PPS and Non-ABC mode.
6. Place 2 mm of Copper (or equivalent homogeneous phantom) in the Collimator Filter Holder.
7. Calculate the value of the optimum radiation (that will give optimum brightness) usually is 2 μ R/frame at 9" FOV (*for more information refer to Image System documentation*).

Examples:

For 25 frame/second optimum radiation is 3 mR/min.

$$2 \mu\text{R/frame} \times 25 \text{ frame/s} = 50 \mu\text{R/s.}$$

$$50 \mu\text{R/s} \times 60 \text{ s/min} = 3000 \mu\text{R/min} = 3 \text{ mR/min.}$$

For 30 frame/second optimum radiation is 3.6 mR/min.

$$2 \mu\text{R/frame} \times 30 \text{ frame/s} = 60 \mu\text{R/s.}$$

$$60 \mu\text{R/s} \times 60 \text{ s/min} = 3600 \mu\text{R/min} = 3.6 \text{ mR/min.}$$

The optimum radiation value should be measured at Image Intensifier Radiation Input. Intensifier grid should be removed, if it can not be removed, this value should be multiplied by two or by the value specified as Grid Absorption Factor.

8. Make a Fluoro exposure at 70 kV and measure the radiation. Optimum radiation is obtained by modifying the Fluoro kV or the Copper thickness in the Collimator Filter Holder. First modify the Fluoro kV, if it is more than 80 kV or less than 60 kV modify the Copper thickness in 0.1 mm (or 0.2 mm). Note the value of Fluoro KV and Copper thickness used to obtain the optimum radiation.

Note 

Radiation increases when kV is increased or Copper thickness is reduced.

9. Perform the adjustment for the window test as specified on the TV Camera manuals. This window defines the area of the image where the brightness will be captured for the ABC and it should be the 25% of the image area.
10. Select the 70 kV (or the kV obtained in step-8.) and Non-ABC mode.
11. Adjust R29 (OFFSET) on the RF Adaptation Board to have 0 VDC in TP7.
12. Adjust gain at R27 (Gain) on the RF Adaptation Board to make the "ABC OUT" signal equal to +6 VDC. Measure "ABC OUT" in TP-7 of RF Adaptation Board or in TP3 ("ABC IN") of the AEC Control Board.
13. Perform the following adjustments in the AEC Control Board:
 - a. Select 70 kV (or the kV obtained in step-8.) and increase 2 kV and check the increased value of voltage in TP3 (ABC-IN). Note this value (**consider it as KV-DOWN-SEL**).
 - b. Select 70 kV (or the kV obtained in step-8.) and decrease 2 kV and check the decreased value of voltage in TP3 (ABC-IN). Note this value (**consider it as KV-UP-SEL**).
 - c. Obtain in TP1 the same voltage noted as kV-DOWN-SEL (DOWN PT) by adjusting the Potentiometer R11.
 - d. Obtain in TP2 the same voltage noted as kV-UP-SEL (UP PT) by adjusting the Potentiometer R14.
14. Select the 70 kV (or the kV obtained in step-8.) and ABC mode.
15. Make a Fluoro exposure and check that the kV does not change.
16. Stop the Fluoro exposure and select 40 kV. Make a Fluoro exposure and check that the kV value goes to 70 kV (or the kV obtained in step-8.) ± 2 kV without System problems.
17. Stop the Fluoro exposure and select 100 kV. Make a Fluoro exposure and check that the kV value goes to 70 kV (or the kV obtained in step-8.) ± 2 kV without System problems.

2.8.2.3 ABC SYSTEM ADJUSTMENT WITH NO ABC SIGNAL FROM TV CAMERA

1. Be sure that the Video System and the Image Intensifier are powered and operating correctly.
2. Set up a Dosimeter as close as possible to the Image Intensifier Radiation Input to measure the Entrance Image Intensifier Exposure Dose Rate. Position the Probe at the center of the primary beam with the entire active volume within the primary beam.

Place the Tube-Collimator Assembly at the normal SID (1 meter), fully open the Collimator Blades and align the Image Intensifier with the light beam.

3. Adjust TV Camera gain for 1 volt peak-to-peak composite video output.
4. Set on the RF Adaptation Board, Jumpers JP21 to position "A" and JP20 to position "A".
5. Select the maximum PPS and Non-ABC mode.
6. Place 2 mm of Copper (or equivalent homogeneous phantom) in the Collimator Filter Holder.
7. Calculate the value of the optimum radiation (that will give optimum brightness) usually is $2\mu\text{R}/\text{frame}$ at 9" FOV (*for more information refer to Image System documentation*).

Examples:

For 25 frame/second optimum radiation is 3 mR/min.

$$2\ \mu\text{R}/\text{frame} \times 25\ \text{frame/s} = 50\ \mu\text{R/s.}$$

$$50\ \mu\text{R/s} \times 60\ \text{s/min} = 3000\ \mu\text{R/min} = 3\ \text{mR/min.}$$

For 30 frame/second optimum radiation is 3.6 mR/min.

$$2\ \mu\text{R}/\text{frame} \times 30\ \text{frame/s} = 60\ \mu\text{R/s.}$$

$$60\ \mu\text{R/s} \times 60\ \text{s/min} = 3600\ \mu\text{R/min} = 3.6\ \text{mR/min.}$$

The optimum radiation value should be measured at Image Intensifier Radiation Input. Intensifier grid should be removed, if it can not be removed, this value should be multiplied by two or by the value specified as Grid Absorption Factor.

8. Make a Fluoro exposure at 70 kV and measure the radiation. Optimum radiation is obtained by modifying the Fluoro kV or the Copper thickness in the Collimator Filter Holder. First modify the Fluoro kV, if it is more than 80 kV or less than 60 kV modify the Copper thickness in 0.1 mm (or 0.2 mm). Note the value of Fluoro KV and Copper thickness used to obtain the optimum radiation.

Note 

Radiation increases when kV is increased or Copper thickness is reduced.

9. Perform the adjustment for the window test. This window defines the area of the image where the brightness will be captured for the ABC.
 - a. Calculate the image area πr^2 (clear circle on the monitor). (r=circle radius).
 - b. Calculate the 25% of the image area ($\pi r^2/4$).
 - c. Calculate the sides of the window: $l = \sqrt{\pi r^2/4}$ (l= side of square).
 - d. Mark the calculated area on the monitor (square).
 - e. Position jumper JP18 of RF Adaptation Board in "A". A window will be displayed on the monitor.
 - f. Adjust in the RF Adaptation Board the following potentiometers to move the window under the frame marked on the monitor in step-d:
 - R1 potentiometer (vertical position)
 - R2 potentiometer (vertical width)
 - R3 potentiometer (horizontal position)
 - R4 potentiometer (horizontal width)
 - g. Once the window is configured, place JP18 in "B" again at RF Adaptation Board.
10. Select the 70 kV (or the kV obtained in step-8.) and Non-ABC mode.
11. Adjust the gain at R27 on the RF Adaptation Board to make the "ABC OUT" signal equal to +6 VDC. Measure "ABC OUT" in TP7 of RF Adaptation Board or in TP3 ("ABC IN") of the AEC Control Board.

12. Perform the following adjustments in the AEC Control Board:
 - a. Select 70 kV (or the kV obtained in step-8.) and increase 2 kV and check the increased value of voltage in TP3 (ABC-IN) (if this value has not been increased, increase 1 kV more). Note this value (**consider it as KV-DOWN-SEL**).
 - b. Select 70 kV (or the kV obtained in step-8.) and decrease 2 kV and check the decreased value of voltage in TP3 (ABC-IN) (if this value has not been decreased, decrease 1 kV more). Note this value (**consider it as KV-UP-SEL**).
 - c. Obtain in TP1 the same voltage noted as kV-DOWN-SEL (DOWN PT) by adjusting the Potentiometer R11.
 - d. Obtain in TP2 the same voltage noted as kV-UP-SEL (UP PT) by adjusting the Potentiometer R14.
13. Select the 70 kV (or the kV obtained in step-8.) and ABC mode.
14. Make a Fluoro exposure and check that the kV does not change.
15. Stop the Fluoro exposure and select 40 kV. Make a Fluoro exposure and check that the kV value goes to 70 kV (or the kV obtained in step-8.) ± 4 kV without System problems.
16. Stop the Fluoro exposure and select 100 kV. Make a Fluoro exposure and check that the kV value goes to 70 kV (or the kV obtained in step-8.) ± 4 kV without System problems.

2.9 FINAL CHECKS

Verify that all Configuration and Calibration data have been properly stored in memory.

1. Enter in calibration mode and check that the values noted for the “*Filament Current Numbers*” and “*Extended Memory Locations*” tables of the Data Book are the same that the values displayed and stored in memory. Press the “*Read*” button to read the stored values.
2. Exit from calibration mode and Service mode.
3. Turn the Generator OFF and verify position of dip switches on the HT Controller Board are:
 - Dip switch 3000SW2-2 in “**Off**” position (enables Filament and Rotor Interlocks).
 - Dip switch 3000SW2-4 in “**Off**” position (Digital mA Loop Closed).
4. Set the Test dip switch 3024SW2-3 on the ATP Console CPU Board in “**Off**” position to place the Generator in normal operating mode.