

Technical Publication
CF-1018R3

Configuration

HF Series Generators

REVISION HISTORY

REVISION	DATE	REASON FOR CHANGE
0	OCT 30, 2003	First edition
1	APR 1, 2005	Documentation upgrade
2	AUG 1, 2005	Anode Stator Configuration
3	OCT 10, 2005	Documentation upgrade

This Document is the English original version, edited and supplied by the manufacturer.

The Revision state of this Document is indicated in the code number shown at the bottom of this page.

ADVISORY SYMBOLS

The following advisory symbols will be used throughout this manual. Their application and meaning are described below.



DANGERS ADVISE OF CONDITIONS OR SITUATIONS THAT IF NOT HEHEDED OR AVOIDED WILL CAUSE SERIOUS PERSONAL INJURY OR DEATH.



ADVISE OF CONDITIONS OR SITUATIONS THAT IF NOT HEHEDED OR AVOIDED COULD CAUSE SERIOUS PERSONAL INJURY, OR CATASTROPHIC DAMAGE OF EQUIPMENT OR DATA.



Advise of conditions or situations that if not heeded or avoided could cause personal injury or damage to equipment or data.

Note 

Alert readers to pertinent facts and conditions. Notes represent information that is important to know but which do not necessarily relate to possible injury or damage to equipment.

TABLE OF CONTENTS

Section	Page
1 INITIAL CONFIGURATION PROCEDURE	1
1.1 Configuration and Test Switches	3
1.1.1 3024SW1 - ATP Console CPU Board	3
1.1.2 3024SW2 - ATP Console CPU Board	3
1.1.3 3024SW3 - ATP Console CPU Board	4
1.1.4 3024SW4 - ATP Console CPU Board	4
1.1.5 3000SW2 - HT Controller Board	4
1.2 Basic Configuration of Generator Boards	5
1.3 AEC Configuration	6
1.4 FLUORO Configuration	7
1.5 Generator Service Mode	9
1.6 Exposure Counters	11
1.7 Workstations Configuration	12
2 EXTENDED MEMORY SETTING	17
2.1 Extended Memory Locations	17
2.2 How to Enter and Store Data in the Extended Memory	19
2.3 Limit of Maximum kW	21
3 X-RAY TUBE SELECTION	23
3.1 X-ray Tube Insert Protection Curves	23
3.2 Generators with LF-RAC (Low Speed Starter)	24
3.2.1 Stator Voltage and Capacitor Selection	24
3.2.1.1 Configuration for One or Two Tubes with Standard Stator	24
3.2.1.2 Configuration for One or Two Tubes with the same	
Starting Voltage at 110 VAC	24
3.2.1.3 Configuration for Two Tubes with Different	
Starting Voltage and Capacitor or One Tube	
with Starting Voltage at 330 VAC	25
3.2.2 Programming of Rotor Acceleration Time, RAD Filament Setting Time,	
FLUORO Rotor and Filament Hold-over Time	27

Section	Page
3.3 Generators with LV-DRAC (High Speed Starter)	29
3.3.1 Anode Stator Selection	29
3.3.2 Programming of RAD Filament Setting Time and FLUORO Filament Hold-over Time	29
3.4 Anode Rotation Test	32
3.5 Focal Spots Configuration	33
4 X-RAY TUBE DATA	35

SECTION 1 INITIAL CONFIGURATION PROCEDURE

Configuration provides the initial settings for extended memory and checkout procedures that must be carried out before making X-ray exposures. Functional characteristics of this Generator are defined at the time of installation.

Calibration and some configuration data are stored in a non-volatile memory chip (U3-EEPROM) located on the HT Controller Board in the Power Cabinet.

When the initial setup and checkout has been completed the Generator will be ready for Calibration.

Note 

Record all the configuration settings in the Data Book.



DO NOT SUPPLY THE MAIN POWER UNTIL SPECIFICALLY INSTRUCTED TO DO SO IN THIS DOCUMENT.

THE MAIN CAPACITORS OF THE HIGH VOLTAGE INVERTER RETAIN A LARGE PORTION OF THEIR CHARGE FOR APPROX. 3 MINUTES AFTER THE UNIT IS TURNED OFF.

The Generator configuration is determined by:

- X-ray tube(s) number, model and use.
- System requirements (Bucky, Tomo, AEC, ...)
- Maximum kV, kW.

Specific versions of U24-EEPROM on the ATP Console CPU Board and U5 on the HT Controller Board are based on the Generator configuration. (*Refer to Illustration 1-1*).

The system configuration and test switches are:

DIP SWITCH LOCATION	FUNCTION
3024SW1 - ATP Console CPU Board	System Configuration
3024SW2 - ATP Console CPU Board	Test
3024SW3 - ATP Console CPU Board	No used for Configuration
3000SW2 - HT Controller Board	System Configuration and Test

Illustration 1-1
EPROM and Switch locations

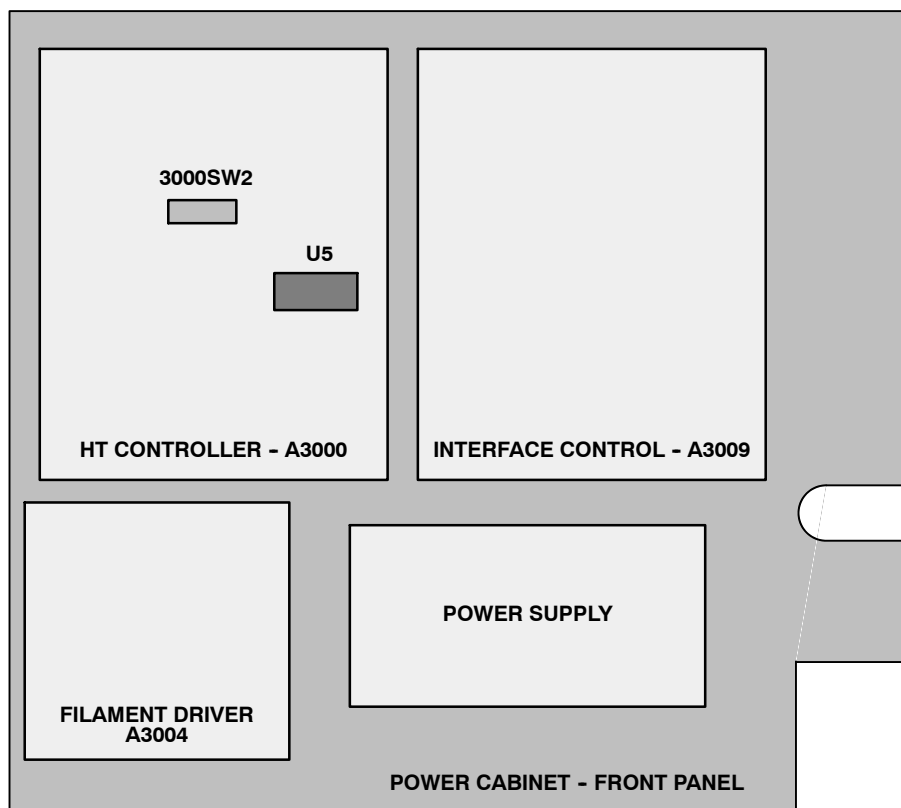
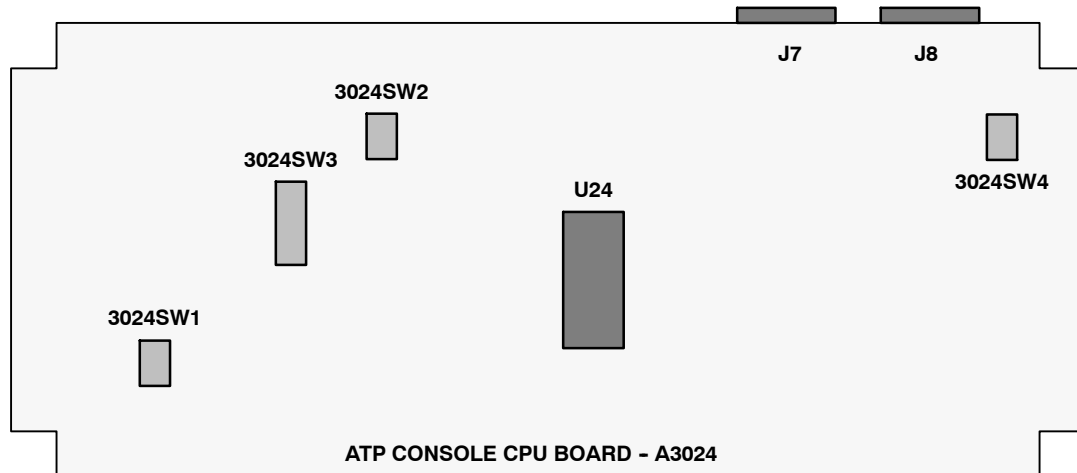

1.1 CONFIGURATION AND TEST SWITCHES

ATP Console Dip Switches must be configured with the Generator turned OFF, and they are read when the Generator is turned ON again.

1.1.1 3024SW1 - ATP CONSOLE CPU BOARD

Set dip switch 3024SW1 in accordance with the Table 1-1.

Table 1-1
System Configuration Dip Switch 3024SW1 on the ATP Console CPU Board

3024SW1 POSITION	OPEN (OFF)	CLOSED (ON)
1	60 Hz ^{*1)}	50 Hz ^{*1)}
2	-	Normal - Application mode. Exposures are inhibited when Door Interlock Switch is opened.
3	Not used. Set in "OFF" position.	Not used.
4	Not used. Set in "OFF" position.	Not used.
<i>Note. - ^{*1)} This switch is related with the frequency of the Rotor Controller. For Generators with High Speed Starter (LV-DRAC) or Generators Powered through Batteries with Stand-Alone set always SW1-1 to 60 Hz, in the rest of Generators set SW1-1 in accordance with the Power Line Frequency.</i>		

1.1.2 3024SW2 - ATP CONSOLE CPU BOARD

Set dip switch 3024SW2 verifying that each position is set as Table 1-2.

Table 1-2
Test Dip Switch 3024SW2 on the ATP Console CPU Board

3024SW2 POSITION	OPEN (OFF)	CLOSED (ON)
1	Skips reception with the HT Controller. Use only for display purposes, troubleshooting or Demo Consoles when there is no Power Module. Be sure that J3 connector is not plugged to the ATP Console CPU Board.	Normal - Application mode.
2	Tick Sound (button / command acknowledge) is not emitted by the ATP Console CPU Board.	Tick Sound (button / command acknowledge) is emitted by the ATP Console CPU Board.
3	Normal - Application mode.	Service Mode .
4	kV Log (Renard) Scale Mode for kV variation (kV changes in logarithmic steps) (if available).	kV Lineal Scale Mode for kV variation (Normal mode) (kV changes one by one).

HF Series Generators

Configuration

1.1.3 3024SW3 - ATP CONSOLE CPU BOARD

Dip switch 3024SW3 is not used for configuration but all their switches must be set in “**Off**” position.

1.1.4 3024SW4 - ATP CONSOLE CPU BOARD

Dip Switch 3024SW4 is not used for configuration but all their switches must be set in “**Off**” position.

1.1.5 3000SW2 - HT CONTROLLER BOARD

HT Controller Dip Switches can be configured while the Generator is ON except Dip Switch 3000SW2-1.

Set dip switch 3000SW2 as indicated in Table 1-3.

**Table 1-3
Test Dip Switch 3000SW2 on the HT Controller Board in the Power Module**

3000SW2 POSITION	OPEN (OFF)	CLOSED (ON)
1	Normal.	Programming of Rotor Acceleration Time, RAD Filament Setting Time, Fluoro Rotor and Filament Hold-over Time ^{*1)} ^{*2)}
2	Normal.	Bypasses: Filament, Rotor Ready, Error E11. ^{*1)} ^{*3)}
3	Normal - Not used.	Not used.
4	Normal - Digital mA Loop Closed	Digital mA Loop Open / Filament Current Constant ^{*1)}
5	125 kV ^{*4)}	150 kV ^{*4)}
6	All Generators except Tube-2 for RAD	Generators with Tube-2 for RAD only.
7	Filament Boosting for Tube-1	No Filament Boosting for Tube-1 ^{*5)}
8	Filament Boosting for Tube-2	No Filament Boosting for Tube-2 ^{*5)}

Notes.- ^{*1)} Set in Closed (On) position only when indicated in the Service Manual.

^{*2)} Note that SW2-1 in Closed (On) position is only set to program the Rotor Acceleration Time, Rad Filament Setting Time, Fluoro Rotor and Filament Hold-over Time, therefore it changes the functions of Switches SW2-2 and SW2-4 to SW2-8. Refer to Section 3.

^{*3)} This turns off the filaments so no radiation will be produced during the exposure.

WARNING: THE KV OUTPUT OF THE HV TRANSFORMER WILL BE WHATEVER IS SET BY THE CONSOLE. IF THE X-RAY TUBE HV CABLES ARE NOT CONNECTED INTO THE HV TRANSFORMER, FILL COMPLETELY BOTH HV RECEPTACLES WITH HV OIL.

^{*4)} Set SW2-5 according to the Generator kV rating (refer to the Generator model and/or specifications).

^{*5)} Set to “No Filament Boosting” when using X-ray Tubes with Small Focal Spot smaller than 0.6 .

1.2 BASIC CONFIGURATION OF GENERATOR BOARDS

The following Jumpers are factory set or removed to configure the Generator Boards according to the customer order. Check the jumper positions in the Generator Boards.

GENERATOR BOARDS	JUMPERS POSITION
HT CONTROLLER	JP1 and JP2 in "2"
	JP3, JP5 and JP6 in "2" and JP4 in "1" : for Compact Generators.
FILAMENT CONTROL	W1 in "A"
INTERFACE CONTROL	W1 in "2-3"
	W2 in "1-2"
	W3 to W10 in "A" : for positive High Voltage supply for Ion Chamber W3 to W10 in "B" : for negative High Voltage supply for Photomultiplier Tube
ATP CONSOLE CPU	JP1, JP2 and JP3 in "B" (soldered)
	JP4 in "B" (Cam-Sync)
	JP5 in "B" : Standard JP5 in "C" : for R&F / DSI Generators with AEC Control Board A3012-02/05
	JP6 in "A" (soldered)
	Connector J8 configured for RS232 so: JP9, JP10 and JP11 in "A". JP7, JP8, JP21 and JP22 do not matter jumpers position
	JP12 removed
	JP13 installed (set) : if AEC Control Board A3012-xx is installed JP13 removed : if AEC Control Board A3012-xx is not installed
	JP14 installed (soldered)
	JP15, JP16, JP17 and JP18 removed
	JP19 in "A" (soldered)

1.3 AEC CONFIGURATION

Configure the following Jumpers on the “AEC Control Board” (located over the “ATP Console CPU Board”) and on the “AEC Adaptation Board” when this option is installed in the Generator Cabinet.

AEC CONTROL BOARD (A3012-01/02/05)

JUMPER			DESCRIPTION
JP1	A	FOR TV CAMERA	A3012-05: JP1-C, JP2-A AND JP4-B FOR FOURTH ION CHAMBER & ATS-DIG A3012-02: JP1-A, JP2-A AND JP4-A FOR ABC WITH TV CAMERA A3012-01: JP1-B, JP2-B AND JP4-A FOR ABC WITH PHOTOMULTIPLIER
	B	FOR PHOTOMULTIPLIER	
	C	FOURTH ION CHAMBER & ATS-DIG	
JP2	A	FOR TV CAMERA	
	B	FOR PHOTOMULTIPLIER	
JP4	A	FOR PHOTOMULTIPLIER - AEC	
	B	FOR ION CHAMBER - AEC & ATS-DIG	
JP3	A	FOR HIGH SENSITIVITY	JP3-A FOR AEC WHEN USING ION CHAMBER WITH HIGH SENSITIVITY
	B	FOR LOW SENSITIVITY	JP3-B FOR AEC WHEN USING ION CHAMBER WITH LOW SENSITIVITY
NOTE:			<p>HIGH SENSITIVITY IS > 2 V / mR (> 0.223 V / μGy) (a.e. Vacutec Ion Chamber)</p> <p>LOW SENSITIVITY IS < 2 V / mR (< 0.223 V / μGy) (refer to Ion Chamber documentation)</p>

AEC CONTROL BOARD (A3012-06/07/09)

JUMPER			DESCRIPTION
JP1	A	FOR TV CAMERA	JP1-A FOR ABC WITH TV CAMERA
	B	FOR PHOTOMULTIPLIER	JP1-B FOR ABC WITH PHOTOMULTIPLIER
	C	EXTERNAL kV CONTROL	JP1-C FOR ABC WITH EXTERNAL kV UP & DOWN CONTROL
JP2	A	FOR HIGH SENSITIVITY	JP2-A FOR AEC WHEN USING ION CHAMBER WITH HIGH SENSITIVITY
	B	FOR LOW SENSITIVITY	JP2-B FOR AEC WHEN USING ION CHAMBER WITH LOW SENSITIVITY
JP3	B	FOR NORMAL OPERATION	JP3-B FOR NORMAL OPERATION
JP4	A	FOR NORMAL OPERATION	JP4-A FOR NORMAL OPERATION (Only in A3012-06)
NOTE:			<p>HIGH SENSITIVITY IS > 2 V / mR (> 0.223 V / μGy) (a.e. Vacutec Ion Chamber)</p> <p>LOW SENSITIVITY IS < 2 V / mR (< 0.223 V / μGy) (refer to Ion Chamber documentation)</p>

AEC ADAPTATION BOARD (A3263-03)

ION CHAMBER TYPE	JUMPERS POSITION		
	JP3, JP4, JP7, JP8	JP1, JP2, JP5, JP6	JP13, JP14, JP15, JP16
IC1 = IC2 = IC3 = IC4 (Default)	B	B	B
IC1 = IC2 = IC3	B	B	A
IC1 = IC2	B	A	A
IC1 ≠ IC2 ≠ IC3 ≠ IC4	A	A	A

ION CHAMBER OUTPUT	JUMPERS POSITION			
	JP9 (IC1)	JP10 (IC2)	JP11 (IC3)	JP12 (IC4)
NO-OFFSET ADJUSTMENT (Default)	A	A	A	A
OFFSET ADJUSTMENT	B	B	B	B
TEST POINT AND POTENTIOMETER (ONLY IF JUMPER IS IN "B" POSITION)	TP1 - R11	TP2 - R8	TP4 - R2	TP12 - R5

1.4 FLUORO CONFIGURATION

Fluoro configuration depends on position of jumpers W1 and W2 in the "Fluoro CPU Board" and jumper JP4 in the "Console CPU Board", as indicated below:

JUMPERS IN FLUORO CPU BOARD (A3213-XX)	INSERTED	REMOVED
W1	ABC not enable	ABC enable
W2	Always inserted (installed)	

JUMPERS IN ATP CONSOLE CPU BOARD (A3024-XX)	
JP4	Always in "B" position - Camera

HF Series Generators

Configuration

Also, configure the following Jumpers on the optional “*RF Adaptation Board*”.

RF ADAPTATION BOARD (A3514-04)

JUMPER	POSITION	FUNCTION
JP1, JP3, JP4, JP8, JP9, JP10, JP12, JP13, JP14	Set all jumpers	+24 VDC for the inputs PREP ORDER, RAD ORDER, and FLUORO ORDER
	Remove all jumpers	230 VAC for the inputs PREP ORDER, RAD ORDER, and FLUORO ORDER
	Set only JP1, JP8 and JP12	115 VAC for the inputs PREP ORDER, RAD ORDER, and FLUORO ORDER
JP2	Set	Generator +24 VDC for PREP / RAD / FLUORO ORDER
	Removed	External supply for PREP / RAD / FLUORO ORDER
JP5	A	ZOOM 1 output selected from Generator (-9 IN SEL)
	B	ZOOM 1 output selected from Table or external control
JP6	A	ZOOM 2 output selected from Generator (-6 IN SEL)
	B	ZOOM 2 output selected from Table or external control
JP7	A	ZOOM 3 output selected from Generator (-4 IN SEL)
	B	ZOOM 3 output selected from Table or external control
JP11	A	LIH output through a N.O. contact
	B	LIH output through a N.C. contact
JP15	A	LIH output selected from an external enable signal
	B	LIH output selected for Last Image Hold function
JP16	A	EXP ON/END output active for only RAD exposure
	B	EXP ON/END output active for Fluoro and RAD exposure
JP17	A	For EXP ON output active along the RAD exposure
	B	For EXP END output active about 50 ms pulse at the end of the RAD exposure
JP18	A	For ABC Window adjustment
	B	For normal operation
JP19	A	Pulsed Fluoro sync. activated with the negative edge of Exp. Sync+
	B	Pulsed Fluoro sync. from composite video signal (video in)
	C	Pulsed Fluoro sync. activated with the positive edge of Exp. Sync+
JP20	A	For ABC OUT signal from composite video signal (video in)
	B	For ABC OUT signal from a negative external ABC signal
	C	For ABC OUT signal from a positive external ABC signal
JP21	A	ABC OUT signal generated from composite video signal or external ABC signal
	B	ABC OUT signal coming directly from the Image System
JP22	Set	ABC OUT signal generated from composite video signal or external ABC signal
	Removed	ABC OUT signal coming directly from the Image System
JP23	Set	Normal position (composite video signal referenced to the Generator ground)
	Removed	To reduce noise (composite video signal isolate from Generator ground)
JP24	A	Normal position (Fluoro order from the Table sent directly to the Generator)
	B	For Fluoro order enable (Fluoro order from the Table sent to the Image System)

1.5 GENERATOR SERVICE MODE

The Generator Service Mode (GSM) program allows the access to the service screens for Reading the Exposure Counters, Configuration and Calibration procedures.

Start the GSM program by clicking on the “TechService” icon in the path: “StartMenu/Programs/Tech Service/TechService”. (This is the path by default after installing the program from the CD-Rom).

After accessing to the GSM program, a black Information Area appears at the lower right corner of the screen to show some messages related with the process (a.e. “Power Up the Generator”).

If after pressing the “Configuration”, “Calibration” or Auto Calibration” buttons, the GSM program prompts an error message: “Please check calibration dip switch and toggle with power off”; it means that these functions are disabled because position of dip switch 3024SW2-3 on the “ATP Console CPU Board” is not in “Service Mode Allowed”. Turn OFF the generator, change the dip switch 3024SW2-3 to Closed (ON) position, turn ON the generator and start the GSM program again.

Illustration 1-2
GSM Menu

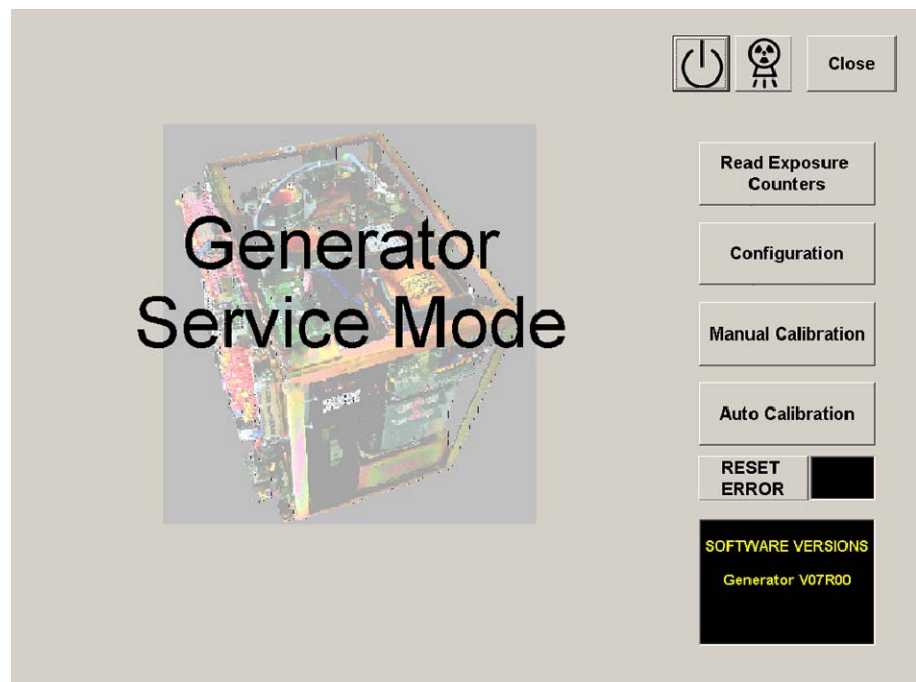

The screens to “Read Exposure Counters”, to enter in “Configuration”, “Manual Calibration” or “Auto Calibration” are displayed after selecting the respective button on the right side. Press again the selected button (in yellow on the right side) to return to the GSM menu.

The “Cancel” button can also be used to return to the GSM menu, specially if the others buttons are disable.

Note 

Whenever the “Configuration” menu is closed (by pressing any of “Configuration” or “Cancel” buttons) a double-beep will sound confirming the storage of the values set for each workstation.

During operation of the GSM program the color of the selected buttons changes to yellow when they are selected.

Press the “Close” button to exit from the GSM program.

Exposure status indicators for “Ready” and “X-ray On” are located on the upper right area of the GSM screens. The “Information Area” displays data related to the service mode, remaining heat units, working mode, errors indicators, etc.

When an error code or message is displayed on the GSM program press the “Reset Error” button to reset the error indication.

**Illustration 1-3
Status and Error Indicators**

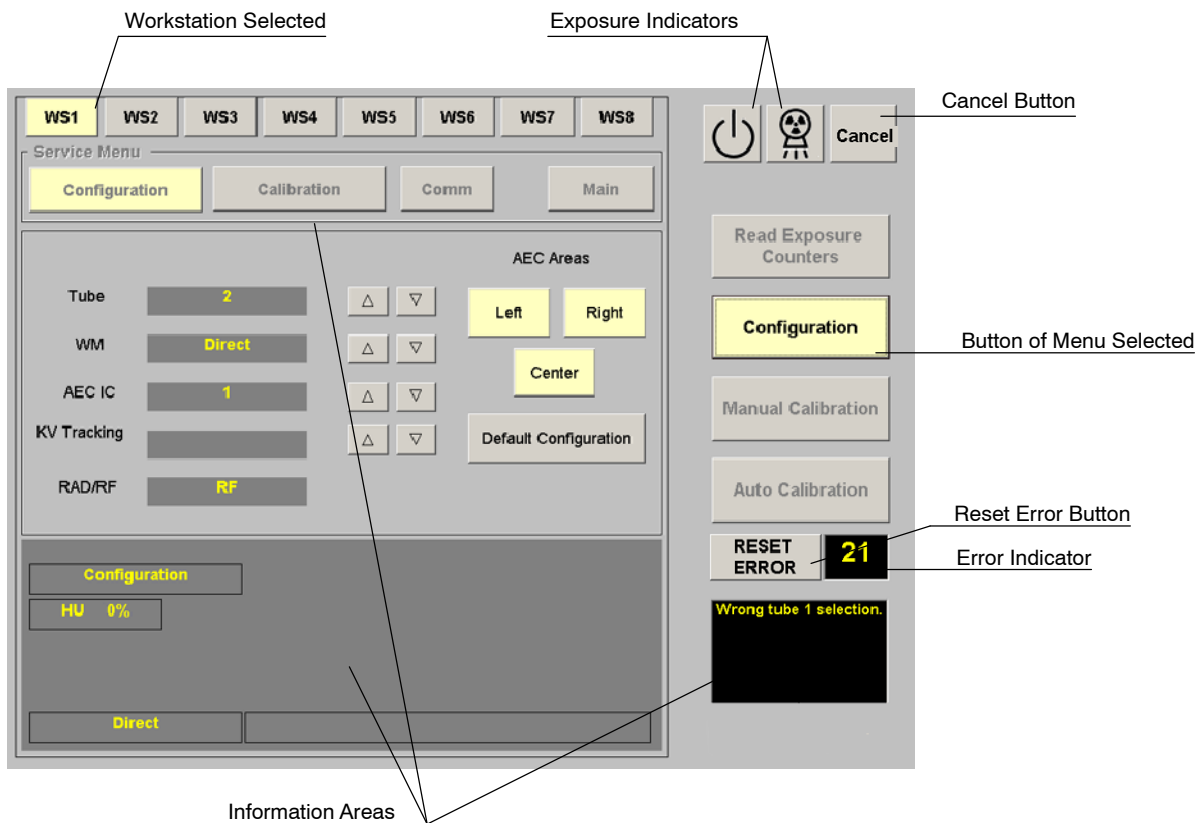

1.6 EXPOSURE COUNTERS

The Exposure Counters display the number of Rad exposures made with any of the X-ray Tubes and the accumulated Fluoro exposure time (in hours and minutes) made with the Tube-2.

1. Enter in the GSM program and select the “*Read Exposure Counters*” button.
2. This screen shows the Exposure Counters.
3. Exit from this screen by pressing the “*Read Exposure Counters*” button or the “*Cancel*” button again.

Illustration 1-4
Exposure Counters

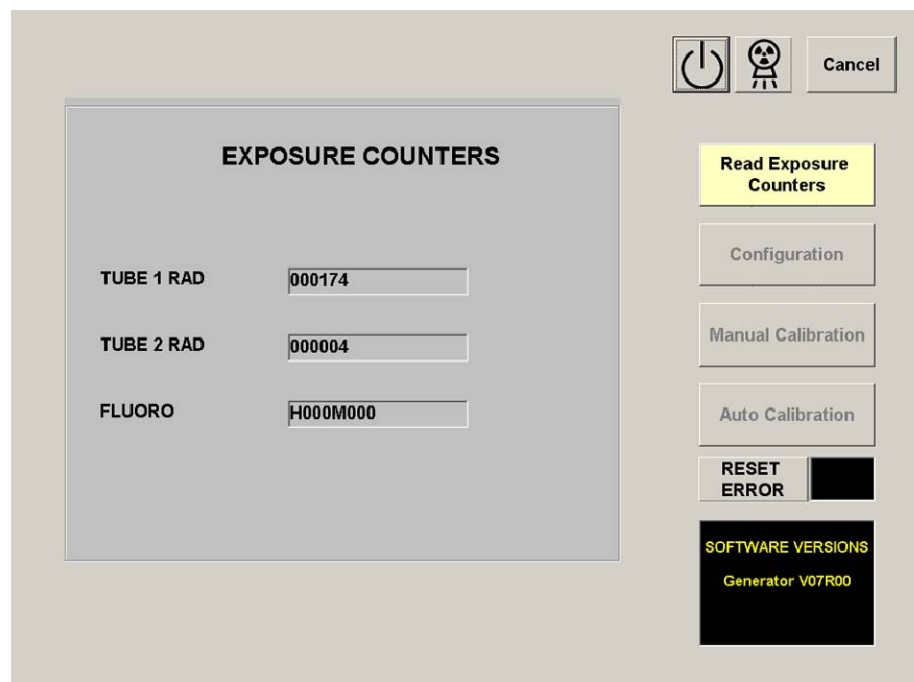

1.7 WORKSTATIONS CONFIGURATION

This screen is used to view the configuration of the Workstations (Tube, WM, Ion Chamber, etc.) and the AEC Areas selected by default for each Workstation in the system (optional).

The workstations can be configured according to the customer preferences or default. If a workstation is configured with the value “Tube - 0”, its button can not be selected during operation.

CUSTOMIZED CONFIGURATION

Note 

This procedure has to be performed always that “ATP Console CPU Board” is replaced by a new one.

1. Enter in the GSM program and select the “Configuration” button.
2. Once in Configuration mode, if the Generator has installed the “Fluoro CPU Board” the program has to indicate “RF” on the RAD/RF window. This means that Fluoro functions are enabled.

Note 

If the Fluoro functions are not enabled (“RF” does not appear) the Fluoro Display and functions will be deactivated after selecting a workstation for Tube-2. In this case, exit, check connection between the Fluoro CPU and ATP Console CPU Board and enter in Configuration again until the “RF” indication appears.

**Illustration 1-5
Configuration**



- Select the first workstation to be configured, by pressing the respective button (only the icon of the selected workstation has different color). The console shows one of the following values:

DISPLAY	FUNCTION	VALUE	DESCRIPTION
1 st Value	TUBES	0	No-configured workstation
		1	Tube-1
		2	Tube-2
2 nd Value	DEVICES - WORKING MODE	0 - Direct	Direct (No Bucky)
		1 - Bucky 1	Bucky-1
		2 - Bucky 2	Bucky-2
		3 - STD Tomo	Standard Tomo *1)
		4 - STD RF	Standard RF (Spot Film Device)
		5 - DSI	Digital RAD and Fluoro *2)
		6 - Cine	Cine *2)
3 rd Value	ION CHAMBERS	0	No AEC
		1	Ion Chamber-1 (IC-1)
		2	Ion Chamber-2 (IC-2)
		3	Ion Chamber-3 (IC-3)
		4	Ion Chamber-4 (IC-4)
		5	Photomultiplier (PT-INPUT)
4 th Value	kV TRACKING (OPTIONAL)	1	Formula-1
		2	Formula-2
		3	Formula-3
		4	Formula-4
		5	Formula-5
		6	Formula-6
		7	Formula-7
		8	Formula-8

Notes:

- Some of listed values are not configurable depending on the Generator model .

*1) Only when the Tomo is controlled from the Generator. In this case, the workstation has to be configured as Tube "1" or "2", Device "STD Tomo" and Ion Chamber "0".
If the Tomo is controlled from the Table, the workstation has to be configured as Tube "2", Device "STD RF" and Ion Chamber "0".

*2) These Devices are only available for Generators provide with interface option for Digital Systems. These workstations has to be configured as Tube "2".

4. Set the new value by pressing the corresponding “Increase” or “Decrease” buttons. Value on “KV Tracking” (optional) assigns by default one Formula for “Zero Point” operation mode to the selected RF workstation. Set also the selected AEC Areas by default for each Workstation in the system (optional).
5. Select the next workstations to be configured and set the respective values of each one.
6. Exit from configuration mode by pressing the “Configuration” button, then a double-bip will sound confirming the process.
7. Exposures made from workstations configured with:
 - Device “Direct (No Bucky), Bucky-1, Bucky-2 and Standard Tomo” are **only enabled** with the internal “Preparation” and “Exposure” signals controlled by the Handswitch or Rad Footswitch.
 - Device “Standard RF” and “DSI” are **only enabled** with the external signals for “Preparation”, “RAD Exposure” and “Fluoro Exposure”. **Fluoro can only be made from this Device selection.**
 - Device “Infimed: DSI, Cine, DSA” are **only enabled** with the external “Digital Preparation” and “Exposure” signals connected to Terminal Block 4TS3 of the Generator Cabinet.

Note 

1) *Optional “Tomo / Bucky Adaptation Board” (in the Power Cabinet) is required to configure more than two Bucky’s or one Tomo Device in the system.*

For system without the optional “Tomo / Bucky Adaptation Board”, it can only work directly with two Bucky’s, and the value assigned to them must be “1” and “2” in the second value.

2) *TOMO must be always related to Bucky-1. Only one TOMO can be used in the system, so only one of the workstations should be configured with the value “3” in the second value.*

3) *Optional “AEC Control Board” (connected to the Console CPU Board) is required to work with AEC.*

Optional “AEC Adaptation Board” is required to configure any no-standard or more than one Ion Chambers in the system.

DEFAULT CONFIGURATION

Default configuration sets some default values to each workstation. It only should be used to re-initialize the workstation configuration when the complete configuration has been lost or it is not possible to select any workstation.

1. Enter in the GSM program and select the “*Configuration*” button.
2. Press the “*Default Configuration*” button.
3. Exit from configuration mode by pressing the “*Configuration*” button, then a double-bip will sound confirming the process.
4. It is recommended to perform a proper configuration of each workstation in the system after a default configuration.

This page intentionally left blank.

SECTION 2 EXTENDED MEMORY SETTING

2.1 EXTENDED MEMORY LOCATIONS

Miscellaneous configuration and calibration data are stored in the Extended Memory Locations. It is recommended to note the values factory stored in each Memory Location. (Refer to Table 2-1)

Note 

For generators with only one Radiographic X-ray Tube, this tube have to be configured, calibrated and used as Tube-1.

Note 

For generators with a Fluoroscopic X-ray Tube or DSI (Digital RAD), this tube have to be configured, calibrated and used as Tube-2.

For these generators, the value of the E17 Memory Location is not readable as "Tube-2 - Filament stand-by (Autocalibrated)".

Note 

Generators with a single X-ray Tube for Fluoroscopy / Spot Film / DSI (Digital RAD) require to store the respective values of the Memory Locations:

- E17: Tube-2 - Fluoro filament setting.
- E18: Tube-2 - Fluoro tube type.
- E29 and E31: Tube-2 - Exposure Time adjustments.
- Other required Memory Locations.

HF Series Generators

Configuration

Table 2-1
Extended Memory Locations

MEMORY LOCATION	FUNCTION	VALUE
E01	TUBE-1 - RAD filament stand-by (<i>Autocalibrated. Not field changeable</i>)	
E02	TUBE-1 - RAD tube type	
E03	Low Digital mA Loop Closed (from 10 mA to 80 mA)	
E04	AEC-1 calibration	
E05	High Digital mA Loop Closed (from 100 mA)	
E06	kV Loop	
E07	Maximum kW (<i>Factory set. Only field changeable to lower value</i>)	
E08	AEC-1 tracking	
E09	AEC-2 calibration	
E10	AEC-2 tracking	
E11	Not used.	
E12	AEC Density Scale	
E13	TUBE-1 - Exposure Time adjustment - Delay	
E14	Not used.	
E15	TUBE-1 - Exposure Time adjustment - Ceq kV	
E16	Not used.	
E17*	TUBE-2 - RAD filament stand-by (<i>Autocalibrated. Not field changeable</i>)	
	TUBE-2 - FLUORO filament setting	
E18	TUBE-2 - RAD or FLUORO tube type	
E19	Maximum FLUORO kV	
E20	AEC-3 calibration	
E21	Not used.	
E22	Not used.	
E23	AEC-4 calibration / Photomultiplier AEC calibration (SF camera)	
E24	AEC-3 tracking / AEC-4 tracking (equal value for both)	
E25	FLUORO mA display calibration at 50 kV	
E26	FLUORO mA display calibration at 80 kV	
E27	FLUORO mA display calibration at 120 kV	
E28	Not used.	
E29	TUBE-2 - Exposure Time adjustment - Delay	
E30	Not used.	
E31	TUBE-2 - Exposure Time adjustment - Ceq kV	
E32	Not used.	
* Note. - For Fluoroscopic use, value in E17 means "Fluoro filament setting" and must be manually set		

2.2 HOW TO ENTER AND STORE DATA IN THE EXTENDED MEMORY

The Extended Memory data are entered from the Console when the unit is in service mode. Access to memory locations as indicated below:

1. Turn the Generator OFF and set the Test dip switch 3024SW2-3 on the ATP Console CPU Board in “**On**” position to permit the service mode.
2. Power ON the System and select the “*Manual Calibration*” button on the GSM program.
3. Select the needed Workstation (WS) using the “*Up*” and “*Down*” buttons, then press the “*OK*” button to enter in calibration mode.

Note 

In calibration mode, only the kV and mA parameters can be modified, values for Time and mAs are factory programmed.

4. Increase the mA value beyond the maximum mA position. The mA Display will show the first Extended Memory location (E01), they will continue sequentially as the “*Increase mA*” button is pressed.

The values stored in each location are shown on the “*Calibration Value*” Display after pressing the “*Read*” button or after pressing the “*Increase*” or “*Decrease*” buttons of this panel. Since these buttons are also used to increase or decrease the stored values, one number should be added or subtracted from the reading, to obtain the current stored value.

5. Select the new value by pressing the “*Increase*” and “*Decrease*” buttons. Each time these buttons are pressed the value displayed on the calibration panel is increased or decreased one step.
6. Store the new value by pressing the “*Store*” button (Check-summ function).

Note 

If the “Store” button is not pressed after a new value is selected, no modified data will be retained.

7. Exit from calibration mode by pressing the “*Manual Calibration*” button again.
8. Turn the Generator OFF and set dip switch 3024SW2-3 on the ATP Console CPU Board in “**Off**” position to place the Generator in normal mode.

Illustration 2-1
Calibration

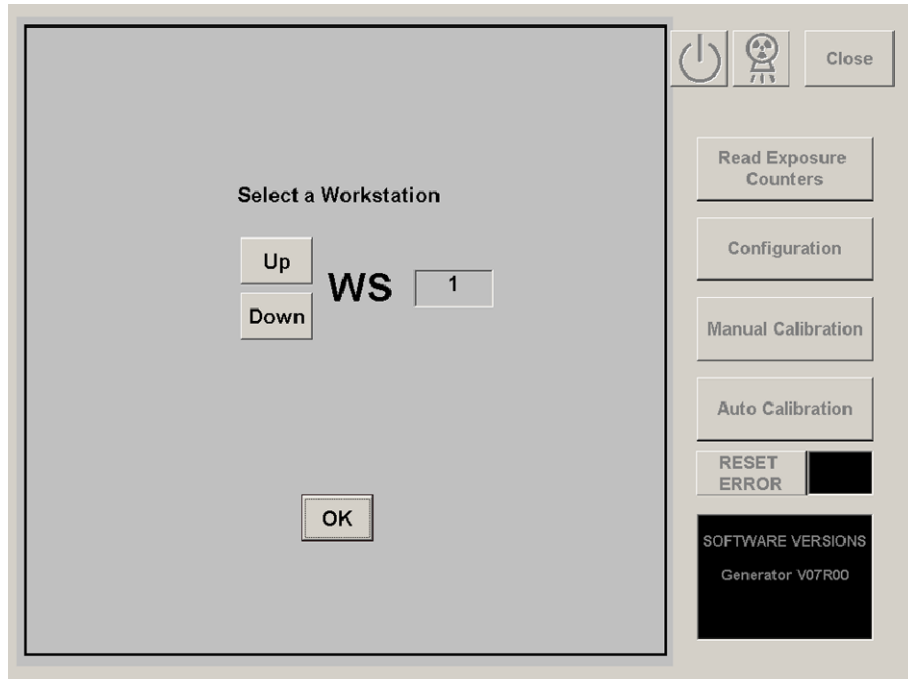

Calibration Value Panel

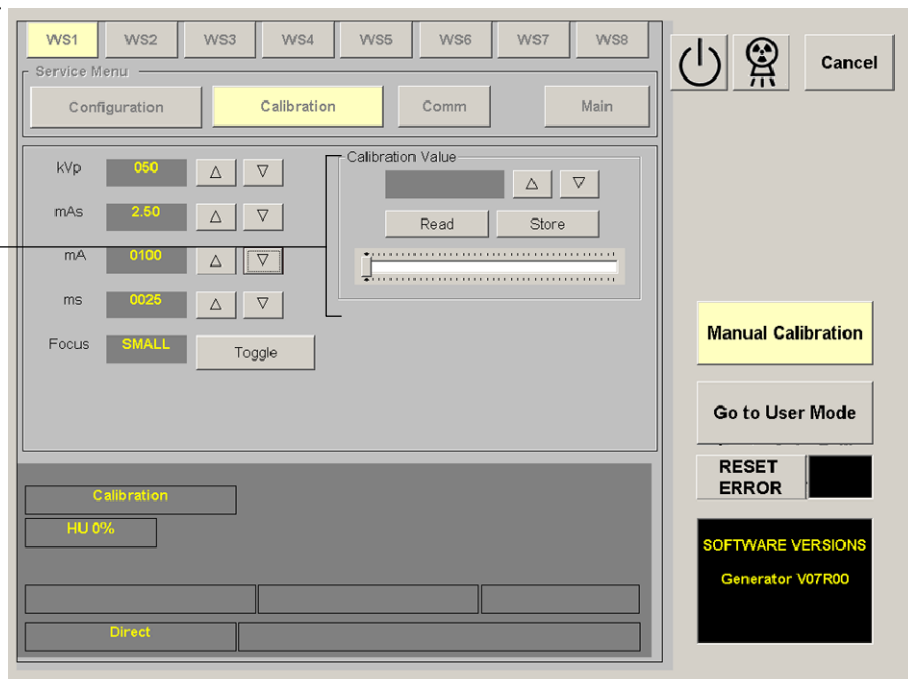

2.3 LIMIT OF MAXIMUM kW

The Maximum kW of the Generator is factory set according to the Generator performance. Generator kW can be limited to a lower value.

Note 

This limit can be set to a lower value to match the maximum Generator power to the Line power, due to a high line impedance (refer to Pre-installation document).

1. Enter in calibration mode by pressing the “Manual Calibration” button on the GSM program. Select any workstation (WS) and press the “OK” button.
2. Select the E07 Memory Location (memory location is shown on the mA Display).
3. Set the new limit of Maximum kW by pressing the “Increase” or “Decrease” calibration buttons and store the value by pressing the “Store” button.
4. Exit from calibration mode.

Note 

Record configuration data for E07 in the Data Book.

This page intentionally left blank.

SECTION 3 X-RAY TUBE SELECTION

3.1 X-RAY TUBE INSERT PROTECTION CURVES

In order to properly select the X-ray Tube Insert Protection Curves for the Tubes connected to the Generator, perform the following procedure:

1. Enter in calibration mode by pressing the “*Manual Calibration*” button on the GSM program. Select one of the workstation (WS) related to the X-ray Tube to be configured. Then press the “*OK*” button.
2. Select the respective memory location, E02 for Tube-1 or E18 for Tube-2 (memory location is shown on the mA Display).
3. Identify in Section 4 “*X-ray Tube Data*”, the X-ray tube that is being installed and note its tube type number.
4. Set the tube number by pressing the “*Increase*” or “*Decrease*” calibration buttons until the correct number is showed on the “*Calibration Value*” panel.
5. Store the value by pressing the “*Store*” button.
6. Verify that the tube code (ID) shown in the mAs Display is the same of the tube code listed in Section 4 “*X-ray Tube Data*”. The tube code (ID) can be only read for the selected X-ray Tube after pressing the “*Store*” button.
7. If required, repeat this procedure for the other X-ray Tube.
8. Exit from calibration mode.

Note 

Record configuration data for E02 and E18 in the Data Book.

3.2 GENERATORS WITH LF-RAC (LOW SPEED STARTER)

3.2.1 STATOR VOLTAGE AND CAPACITOR SELECTION



Check that the capacitor value of the Low Speed Starter corresponds to the value recommended by the X-ray Tube manufacturer. If needed replace the capacitor. Also, the Rotor speed must be indicated by the manufacturer.

The DC Brake of the Low Speed Starter (LF-RAC) can be removed by desoldering CR6 on the LF-RAC Board (*refer to schematic 543020xx*). In this case, the Tube will remain coasting after releasing the “Prep” or the “Fluoro” order.

3.2.1.1 CONFIGURATION FOR ONE OR TWO TUBES WITH STANDARD STATOR

Voltage and capacitor is factory set to 220 VAC, 30 μ F. In all cases, refer to X-ray Tube Product Data.

3.2.1.2 CONFIGURATION FOR ONE OR TWO TUBES WITH THE SAME STARTING VOLTAGE AT 110 VAC

When the stator requires a starting voltage of 110 VAC (a.e. X-ray Tube Toshiba E7239 / E7240 / E7242 / E7252 / E7299 / E7813 / E7865) perform the following modifications:

- If the Power Input Transformer 6T2 is for using with power lines up to 240 VAC (part number 50509030), remove the wire labelled as “4” that is connected to Terminal 4 (230 VAC RTR) and connect it to Terminal 3 or 8 (110 VAC).
- If the Power Input Transformer 6T2 is for using with power lines up to 530 VAC (part number 50509029), remove the wire labelled as “4” that is connected to Terminal 4 (230 VAC RTR) and connect it to Terminal 40 (110 VAC).
- For X-ray Tube Toshiba E7252 or E7813 (or when it is required) replace also the Fuse F1 (6A) on the LF-RAC Board by another fuse of 10 A.



These changes affect to all the Tubes connected to Generator.

3.2.1.3 CONFIGURATION FOR TWO TUBES WITH DIFFERENT STARTING VOLTAGE AND CAPACITOR OR ONE TUBE WITH STARTING VOLTAGE AT 330 VAC

For Generators equipped with a LF-RAC module for two X-ray Tubes, with possible selection of voltage and capacitor jumpers on the LF-RAC Board, set jumpers according to the respective X-ray Tube(s) as indicated below.

TWO TUBES WITH STARTING VOLTAGE AT 220 VAC AND 330 VAC OR ONE TUBE WITH STARTING VOLTAGE AT 330 VAC

(A "Kit of 330 VAC" is required with this configuration).

		TUBE-1	TUBE-2
VOLTAGE	220 VAC	TB2-T1 with TB1-5 or TB1-6	TB2-T2 with TB1-5 or TB1-6
	330 VAC	TB2-T1 with TB1-8 or TB1-9	TB2-T2 with TB1-8 or TB1-9
CAPACITOR	30 μ F	TB3-T1 with TB1-12 or TB1-13	TB3-T2 with TB1-12 or TB1-13
	15 μ F	TB3-T1 with TB1-15 or TB1-16	TB3-T2 with TB1-15 or TB1-16

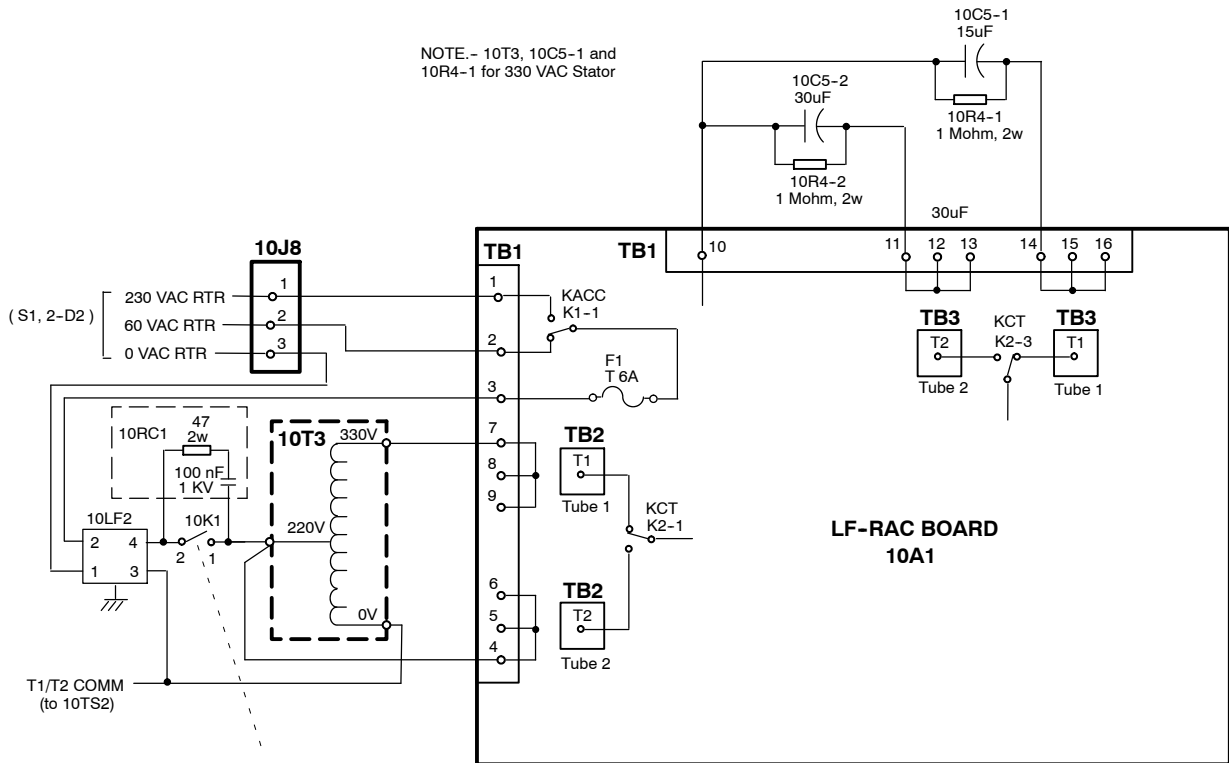

HF Series Generators

Configuration

TWO TUBES WITH STARTING VOLTAGE AT 220 VAC AND 110 VAC

(A "Kit of 110 VAC" is required with this configuration).

		TUBE-1	TUBE-2
VOLTAGE	220 VAC	TB2-T1 with TB1-5 or TB1-6	TB2-T2 with TB1-5 or TB1-6
	150 VAC	TB2-T1 with TB1-8 or TB1-9	TB2-T2 with TB1-8 or TB1-9
CAPACITOR	30 μ F	TB3-T1 with TB1-12 or TB1-13	TB3-T2 with TB1-12 or TB1-13
	15 μ F	TB3-T1 with TB1-15 or TB1-16	TB3-T2 with TB1-15 or TB1-16

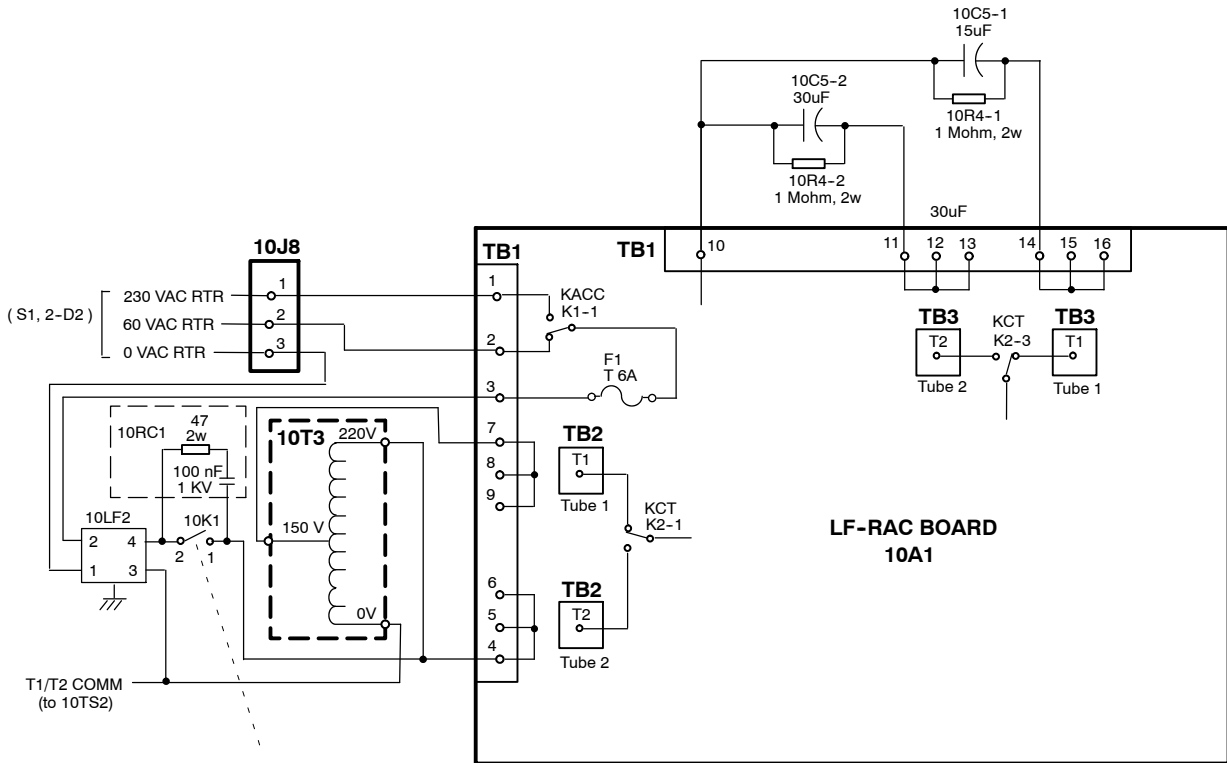

3.2.2 PROGRAMMING OF ROTOR ACCELERATION TIME, RAD FILAMENT SETTING TIME, FLUORO ROTOR AND FILAMENT HOLD-OVER TIME



Rotor Acceleration Time is determined by the X-ray Tube and Rotor characteristics and it must be considered when the Generator is about to be configured. X-ray Tube could be permanently damaged unless the required RPM are reached before an exposure. (Refer to technical information of the X-ray Tube).

Dip Switch 3000SW2 on the HT Controller Board is used to program:

- *Rotor Acceleration Time.* That depends on stator voltage, stator frequency, stator type, quality of X-ray tube bearings, and X-ray tube anode size. A reed tachometer or a stroboscope can be used to determine the anode RPM. Be sure that the Rotor Acceleration Times meet all requirements for anticipated customer applications.

This value is programmable from 0.8 to 2.7 seconds. After this time the Rotor is hold running in maintaining mode as long as "Prep" is active.

- *Rad Filament Setting Time.* This parameter has the same configuration value than the Rotor Acceleration Time. Sometimes, if it is required to increase the Rad Filament Setting Time to the next value, configure the respective switches again. This adjustment avoids Error-12.
- *Fluoro Rotor Hold-over Time and Fluoro Filament Hold-over Time.* This value can be programmed to run for 1 minute or not at all, after releasing the Fluoro Pedal.

Note

The Rotor Acceleration Time and Rad Filament Setting Time is factory set to 1.8 seconds. The Fluoro Rotor Hold-over Time and Fluoro Filament Hold-over Time is factory set to 1 minute. Maintain this value when it is unknown or not provided with the X-ray Tube documentation.

1. Turn the Generator OFF and note current settings of the dip switch 3000SW2 on the HT Controller Board.

Note

Configuration of these times are only allowed when dip switch 3000SW2-1 is in "Closed" (On) position after power the Generator OFF and back ON again.

HF Series Generators

Configuration

- Set dip switches 3000SW2-1 and 3000SW2-2 as indicated below, in order to enable the selection of times with the Low Speed Starter. ***Dip switch 3000SW2-1 has to be switched ONLY with the Generator powered OFF.***

3000SW2-1 (selection enable)	3000SW2-2 (Low Speed Starter)
ON	OFF

- Configure the Rotor and Filament Times by setting the dip switches 3000SW2-4 through 3000SW2-8 per Table 3-1.

Table 3-1
Low Speed: Configuration of Rotor and Filament Times

TUBE-1 ROTOR ACCELERATION TIME AND FILAMENT SETTING TIME	3000SW2-7		3000SW2-8	
	OPEN (OFF)	CLOSED (ON)	OPEN (OFF)	CLOSED (ON)
0.8 seconds		<input type="checkbox"/>		<input type="checkbox"/>
1.2 seconds	<input type="checkbox"/>			<input type="checkbox"/>
1.8 seconds		<input type="checkbox"/>	<input type="checkbox"/>	
2.7 seconds	<input type="checkbox"/>		<input type="checkbox"/>	

TUBE-2 ROTOR ACCELERATION TIME AND FILAMENT SETTING TIME	3000SW2-5		3000SW2-6	
	OPEN (OFF)	CLOSED (ON)	OPEN (OFF)	CLOSED (ON)
0.8 seconds		<input type="checkbox"/>		<input type="checkbox"/>
1.2 seconds	<input type="checkbox"/>			<input type="checkbox"/>
1.8 seconds		<input type="checkbox"/>	<input type="checkbox"/>	
2.7 seconds	<input type="checkbox"/>		<input type="checkbox"/>	

FLURO ROTOR AND FILAMENT HOLD-OVER TIME	3000SW2-4	
	OPEN (OFF)	CLOSED (ON)
After releasing the Fluoro Pedal, the Rotor stops and the Filament Current goes back to stand-by.		<input type="checkbox"/>
After releasing the Fluoro Pedal, 1 minutes passes before the Rotor stops and the Filament Current goes back to stand-by.	<input type="checkbox"/>	

Note 

Record the switch configuration in the Data Book.

- To validate previous configuration, turn the Generator ON, wait until Error-01 (E01) appears on the Console and turn the Generator OFF.
- Set dip switch 3000SW2 to the original settings as noted in step-1. (Refer to Section 1.1.5 for the normal settings of Dip Switch 3000SW2).

3.3 GENERATORS WITH LV-DRAC (HIGH SPEED STARTER)

3.3.1 ANODE STATOR SELECTION

For Generators with High Speed Starter, **configure NOW** the X-ray Tube Family (anode stator + insert) by setting the respective dip switches 3243SW1 (pos. 4 to 8) and / or 3243SW2 (pos. 4 to 8) on the Control DRAC Board. (Refer to "LV-DRAC - Digital Rotating Anode Controller" document).

Configuration of these dip switches automatically determines the appropriate Starting and Running Stator Voltage and Rotor Acceleration Time of the selected Tube Family.

3.3.2 PROGRAMMING OF RAD FILAMENT SETTING TIME AND FLUORO FILAMENT HOLD-OVER TIME

Note 

With High Speed operation:

- *Rotor Acceleration Time is related to the X-ray Tube Family configured on the Control DRAC Board (LV-DRAC).*
- *Fluoro and Spot Film Rotor Hold-over Times are configured on the Control DRAC Board (LV-DRAC).*
- *Rad Filament Setting Time and Fluoro Filament Hold-over Time are configured with dip switch 3000SW2 per this instruction.*

Dip Switch 3000SW2 on the HT Controller Board is used to program:

- *Rad Filament Setting Time.* This value is programmable from 0.8 to 2.7 seconds. It can be initially set as the same value assigned for the Rotor Acceleration Time (refer to technical information of the X-ray Tube)

Sometimes, if it is required to increase the Rad Filament Setting Time to the next value, configure the respective switches again. This adjustment avoids Error-12.

- *Fluoro Rotor Hold-over Time and Fluoro Filament Hold-over Time.* This value can be programmed to run for 1 minute or not at all, after releasing the Fluoro Pedal.

Note 

The Rad Filament Setting Time is factory set to 1.8 seconds. The Fluoro Filament Hold-over Time is factory set to 1 minute. Maintain this value when it is unknown or not provided with the X-ray Tube documentation.

1. Turn the Generator OFF and note current settings of the dip switch 3000SW2 on the HT Controller Board.

Note 

Configuration of these times are only allowed when dip switch 3000SW2-1 is in "Closed" (On) position after power the Generator OFF and back ON again.

2. Set dip switches 3000SW2-1 and 3000SW2-2 as indicated below, in order to enable the selection of times with the High Speed Starter. **Dip switch 3000SW2-1 has to be switched ONLY with the Generator powered OFF.**

3000SW2-1 (selection enable)	3000SW2-2 (High Speed Starter)
ON	ON

- Configure the Filament Setting Times by setting the dip switches 3000SW2-4 through 3000SW2-8 per Table 3-2. The Filament Setting Time should be configured in accordance to Rotor Acceleration Time of the X-ray Tube.

Table 3-2
High Speed: Configuration of Filament Setting Time

TUBE-1 FILAMENT SETTING TIME	3000SW2-7		3000SW2-8	
	OPEN (OFF)	CLOSED (ON)	OPEN (OFF)	CLOSED (ON)
0.8 seconds		<input type="checkbox"/>		<input type="checkbox"/>
1.2 seconds	<input type="checkbox"/>			<input type="checkbox"/>
1.8 seconds		<input type="checkbox"/>	<input type="checkbox"/>	
2.7 seconds	<input type="checkbox"/>		<input type="checkbox"/>	

TUBE-2 FILAMENT SETTING TIME	3000SW2-5		3000SW2-6	
	OPEN (OFF)	CLOSED (ON)	OPEN (OFF)	CLOSED (ON)
0.8 seconds		<input type="checkbox"/>		<input type="checkbox"/>
1.2 seconds	<input type="checkbox"/>			<input type="checkbox"/>
1.8 seconds		<input type="checkbox"/>	<input type="checkbox"/>	
2.7 seconds	<input type="checkbox"/>		<input type="checkbox"/>	

FLUORO FILAMENT HOLD-OVER TIME	3000SW2-4	
	OPEN (OFF)	CLOSED (ON)
After releasing the Fluoro Pedal, the Filament Current goes back to stand-by.		<input type="checkbox"/>
After releasing the Fluoro Pedal, 1 minutes passes before the Filament Current goes back to stand-by.	<input type="checkbox"/>	

Note 

Record the switch configuration in the Data Book.

- To validate previous configuration, turn the Generator ON, wait until Error-01 (E01) appears on the Console and turn the Generator OFF.
- Set dip switch 3000SW2 to the original settings as noted in step-1. (Refer to Section 1.1.5 for the normal settings of Dip Switch 3000SW2).

3.4 ANODE ROTATION TEST

Perform the following tests for each X-ray Tube in the installation, checking the low and high speed when it is required.

Note 

Two people are needed for these tests, one at the Console and the service engineer looking at the anode of the X-ray Tube. These tests also can be done by hearing the sound of the anode rotating.



NEVER MAKE EXPOSURES DURING THE TESTS, THE PERSON CLOSE TO THE X-RAY TUBE WILL BE EXPOSED.

1. With the switch 3024SW2-3 on the ATP Console CPU Board in “**On**” position (service mode), turn the Console ON and select the corresponding X-ray Tube.
2. Select a low value for kVp and mAs for checking the Anode Rotation at Low Speed.
3. Press the “*Prep*” push-button and visually check that the Tube anode rotates in the proper way. (*Refer to the X-ray Tube documentation*).
4. Hold pressed the “*Prep*” push-button and check that the rotation speed of the Tube anode is in compliance with the X-ray Tube specifications.

For this test is recommended to turn off the Tube filaments (switch 3000SW2-2 on the HT Controller in “**On**” position) and use a stroboscope to measure the anode speed.

5. Release the “*Prep*” push-button.
6. For Generators with LV-DRAC, select a high value for kVp and mAs for checking the Anode Rotation at High Speed. Repeat steps 3, 4 and 5.
7. If required for the second Tube, repeat this procedure.

3.5 FOCAL SPOTS CONFIGURATION

This configuration determines which mA station will be the smallest mA station for the Large Focal Spot. It is possible to configure all the mA stations for the Small Focal Spot or for the Large Focal Spot.

The smallest mA station for the Large Focal Spot must be selected according to the Tube ratings for the Small Filament and the customer preference.



IF THE mA STATION FOR FOCAL SPOT CHANGE IS NOT CONFIGURED ACCORDING TO THE X-RAY TUBE RATINGS, THE TUBE FILAMENTS MAY BE PERMANENTLY DAMAGED.

1. With the generator OFF, set dip switch 3024SW2-3 on the ATP Console CPU Board in “**On**” position to permit the service mode.
2. Power ON the System. Enter in calibration mode by pressing the “*Manual Calibration*” button on the GSM program. Select any workstation (WS) of the corresponding X-ray Tube and press the “*OK*” button.
3. Select the smallest mA station for the Large Focal Spot using the “*Increase*” or “*Decrease*” mA buttons. When is required to configure all mA stations for the Small Focal Spot, select “*E01*” Memory Location.

Note

Default value is factory set at 200 mA except when using X-ray Tubes with Small Focal Spot smaller than 0.6 .

4. Press the “*Toggle*” button to store the select mA station and then press the “*Confirm*” or “*Dismiss*” buttons to confirm or cancel the process. When it is confirmed, the ATP Console CPU Board emits a “double-beep”.



IF THE FOCAL SPOT SWITCH-OVER POINT IS CHANGED AFTER mA CALIBRATION, THE mA STATIONS AFFECTED MUST BE RE-CALIBRATED.

5. Exit from calibration mode.

Perform the following test (*it is not mandatory*).

Note 

The test described only applies to RAD Tubes.

In case of a R&F Tube (Tube-2) both filament are always ON (lit). Select a "Direct" workstation and a mA station for the Small Filament. Press "Prep" for RAD and observe through the X-ray Tube window that the Small Filament lights more than the Large Filament.

1. Select the highest mA station for the Small Focal Spot. Verify that effectively the Small Filament is ON (lighted) and the Large Filament is OFF. Observe filaments through the X-ray tube window.
2. Select the lowest mA station for the Large Focal Spot. Verify that effectively the Large Filament is ON (lighted) and the Small Filament is OFF. Observe filaments through the X-ray tube window.
3. If required for the second tube, repeat this procedure.

Illustration 3-1
Focal Spots Configuration

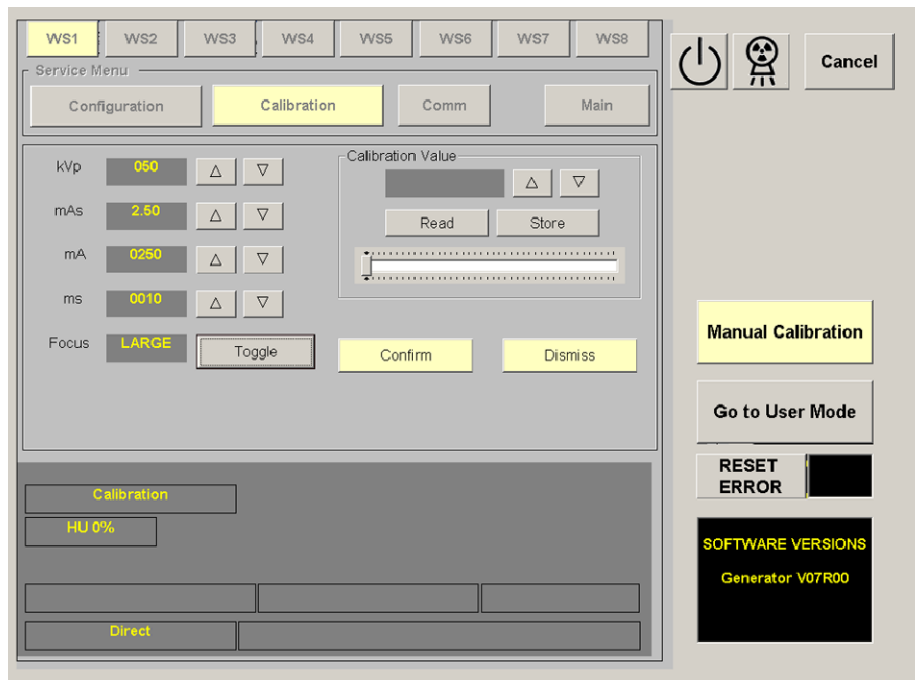

SECTION 4 X-RAY TUBE DATA

The following table lists several common X-ray tubes and their corresponding number. If a specific tube is not listed, tube specifications are given to enable you chose a similar tube type. If none of the listed tubes are satisfactory, contact your generator supplier to obtain special software.

Table 4-1
X-ray Tube Numbers

TUBE NUMBER	TUBE CODE (ID)	MODEL	FOCAL SPOT	POWER RATINGS		KHU
				LS (kW)	HS (kW)	
001	139	TOSHIBA E7239X	1.0 / 2.0	22 / 45	-	133
002	201	TOSHIBA E7240X	0.6 / 1.2	15 / 30	-	140
003	140	TOSHIBA E7242X	0.6 / 1.5	18 / 49	-	187
004	090	TOSHIBA E7252X	0.6 / 1.2	15 / 42	26 / 73	300
005	412	TOSHIBA E7254FX	0.6 / 1.2	23 / 60	40 / 102	400
006	407	TOSHIBA E7884X	0.6 / 1.2	21 / 52		300
007	310	TOSHIBA E7843X	0.6 / 1.2	22 / 49	-	150
008	344	TOSHIBA E7865X	0.3 / 1.0	3 / 40	-	140
009	402	TOSHIBA E7876X	0.6 / 1.2	22 / 53		230
010	260	IAE RTM 101 HS	0.6 / 1.2	22 / 55	37 / 99	400
011	441	TOSHIBA E7886X	0.7 / 1.3	16.9 / 40		300
012	381	TOSHIBA E7869 X	0.6 / 1.2	21 / 55	36 / 96	600
013	404	VARIAN RAD 14	0.6 / 1.2	21 / 54	32 / 77	300
014	161	VARIAN RAD 21	0.6 / 1.2	21 / 64	36 / 100	300
015	395	VARIAN RAD 60	0.6 / 1.2	26.1 / 66	40 / 100	400
016	238	VARIAN RAD 74	0.6 / 1.5	20 / 52	-	200
017	252	VARIAN RAD 92	0.6 / 1.2	26 / 62	40 / 99	600
018	092	VARIAN A-192	0.6 / 1.2	25 / 63	40 / 96	300
019	309	VARIAN A196	0.6 / 1.0	20 / 47	32 / 72	350
020	438	VARIAN A-292	0.6 / 1.2	25 / 62.5	39.6 / 96	400
021	208	VARIAN G 292	0.6 / 1.2	25 / 63	39 / 95	600
022	051	GE-CGR MN 640	1.0 / 1.8	23 / 46	-	150
023	064	GE MAXIRAY-75	0.6 / 1.5	12 / 37	21 / 62	300
024	062	GE MAXIRAY-100	0.6 / 1.25	18 / 55	31 / 100	350
025	261	SIEMENS DR 154/30/50	1.2 / 1.8	31 / 53	-	200
026						
027						

Note . - Power Ratings are for 60 Hz. To calculate Power Ratings for 50 Hz multiply the values by 0.91

TB63 (+S)

This page intentionally left blank.